

# 10 Gbps SFP+ Bi-Directional Transceiver, 60km Reach

1270/1330nm TX / 1330/1270 nm RX

## XTBxxA-60LY

### Product Highlight

- Supports 9.95 Gb/s to 10.3 Gb/s data rates
- Simplex LC Connector Bi-Directional SFP+ Optical Transceiver
- Single 3.3V Supply
- Up to 60 km on 9/125 um SMF
- A:1270 nm DFB Laser transmitter, 1330 nm APD receiver
- B:1330 nm DFB Laser transmitter, 1270 nm APD receiver
- SFP+ MSA SFF-8431 Compliant
- Digital Diagnostic SFF-8472 Compliant
- RoHS compliant and Lead Free
- Operating case temperature: Standard: 0 ~ 70 °C

### Applications

- 10GBASE-ER at 10.3125 Gbps
- 10GBASE-EW at 9.953 Gbps
- Other Optical Links

### Product description

The XTBxxA-60LY series single mode transceiver is small form factor pluggable module for duplex optical data communications such as 10GBASE-ER/EW defined by IEEE 802.3ae. It is with the SFP+ 20-pin connector to allow hot plug capability.

The XTBxxA-60LY module is designed for single mode fiber and operates at a nominal wavelength of 1270 nm or 1330 nm. The transmitter section uses a multiple quantum well DFB, which is class I laser compliant according to International Safety Standard IEC-60825. The receiver section consists of a APD photodiode integrated with a TIA.

## Absolute Maximum Ratings

These values represent the damage threshold of the module. Stress in excess of any of the individual Absolute Maximum Ratings can cause immediate catastrophic damage to the module even if all other parameters are within Recommended Operating Conditions.

Parameters	Symbol	Min.	Max.	Unit
Supply Voltage	V <sub>cc</sub>	-0.5	+3.6	V
Storage Temperature	T <sub>c</sub>	-40	+85	°C
Operating Case Temperature	T <sub>c</sub>	0	+70	°C
Relative Humidity	RH	0	85	%

## Recommended Operating Conditions

Parameter	Symbol	Min.	Typical	Max	Unit
Supply Voltage	V <sub>cc</sub>	3.0	3.3	3.6	V
Supply Current	I <sub>cc</sub>		300	450	mA
Operating Case Temperature	T <sub>c</sub>	0	25	70	°C
Module Power Dissipation	P <sub>m</sub>	-	1	1.5	W

### Notes:

[1] Supply current is shared between VCCTX and VCCR<sub>X</sub>.

[2] In-rush is defined as current level above steady state current requirements.

**Electrical characteristics**( $T_{OP} = 0$  to  $70^{\circ}\text{C}$ ,  $V_{CC} = 3.0$  to  $3.60$  Volts)

Parameter	Symbol	Min.	Typical	Max	Unit	Ref.
Supply Voltage	$V_{CC}$	3.00		3.60	V	1
Supply Current	$I_{CC}$		300	450	mA	1
<b>Transmitter</b>						
Input differential impedance	$R_{in}$		100		$\Omega$	2
Single ended data input swing	$V_{in,pp}$	150		1200	mVpp	
Transmit Disable Voltage	$V_D$	2		$V_{CC}$	V	
Transmit Enable Voltage	$V_{EN}$	$V_{ee}$		$V_{ee}+0.8$	V	3
<b>Receiver</b>						
Output differential impedance	$R_{out}$		100		$\Omega$	2
Single ended data output swing	$V_{out,pp}$	300		700	mV	4
LOS Fault	$V_{LOS\ fault}$	2		$V_{CC_{HOST}}$	V	5
LOS Normal	$V_{LOS\ norm}$	$V_{ee}$		$V_{ee}+0.8$	V	5

**Notes:**

1. Module power consumption never exceeds 1.5W.
2. AC coupled.
3. Or open circuit.
4. Into 100 ohm differential termination.
5. LOS is LVTTTL. Logic 0 indicates normal operation; logic 1 indicates no signal detected.

**Optical characteristics( $T_{OP} = 0$  to  $70^{\circ}C$ ,  $V_{CC} = 3.0$  to  $3.60$  Volts)**

**(XTB23A-60LY, 1270 DFB & APD/TIA)**

Parameter	Symbol	Min.	Typical	Max	Unit	Ref.
<b>Transmitter</b>						
Optical Wavelength	$\lambda_C$	1260	1270	1280	nm	
Side Mode Suppress Ratio	SMSR	30			dB	
Spectral Width(-20dB)	$\Delta\lambda$			1	nm	
Average Output Power	$P_{op}$	1		5	dBm	1
Extinction Ratio	ER	3.5			dB	
Eye Mask		Compliant with IEEE 802.3				
Transmitter and Dispersion Penalty	TDP			3.2	dB	
Average Power of OFF Transmitter				-30	dBm	
Relative Intensity Noise	RIN			-128	dB/Hz	
<b>Receiver</b>						
Average Receiver Power	RSENS			-20	dBm	1,2
Receiver Overload	$P_{MAX}$			-7	dBm	
Centre Wavelength	$\lambda_C$	1320		1340	nm	
LOS De-Assert	$LOS_D$			-25	dBm	
LOS Assert	$LOS_A$	-28			dBm	
LOS Hysteresis		0.5			dB	

**Notes:**

1. Average Receiver Power (Min) is informative and not the principal indicator of signal strength. A received power below this value cannot be compliant.
2. Measured with a PRBS2<sup>31</sup>-1 test pattern @10.3125 Gbps,  $BER \leq 10^{-12}$

**(XTB32A-60LY, 1330 DFB & APD/TIA)**

Parameter	Symbol	Min.	Typical	Max	Unit	Ref.
<b>Transmitter</b>						
Optical Wavelength	$\lambda_c$	1320	1330	1340	nm	
Side Mode Suppress Ratio	SMSR	30			dB	
Spectral Width(-20dB)	$\Delta\lambda$			1	nm	
Average Output Power	$P_{op}$	1		5	dBm	1,2
Extinction Ratio	ER	3.5			dB	
Eye Mask		Compliant with IEEE 802.3				
Transmitter and Dispersion Penalty	TDP			3.2	dB	
Average Power of OFF Transmitter				-30	dBm	
Relative Intensity Noise	RIN			-128	dB/Hz	
<b>Receiver</b>						
Average Receiver Power	RSENS			-20	dBm	2,3
Receiver Overload	$P_{MAX}$	-7			dBm	
Centre Wavelength	$\lambda_c$	1260		1270	nm	
LOS De-Assert	LOS <sub>D</sub>			-25	dBm	
LOS Assert	LOS <sub>A</sub>	-28			dBm	
LOS Hysteresis		0.5			dB	

**Notes:**

1. Output is coupled into a 9/125um SMF.
2. Average Receiver Power (Min) is informative and not the principal indicator of signal strength. A received power below this value cannot be compliant.
3. Measured with a PRBS231-1 test pattern @10.3125 Gbps, BER $\leq$ 10<sup>-12</sup>

## Pin Descriptions

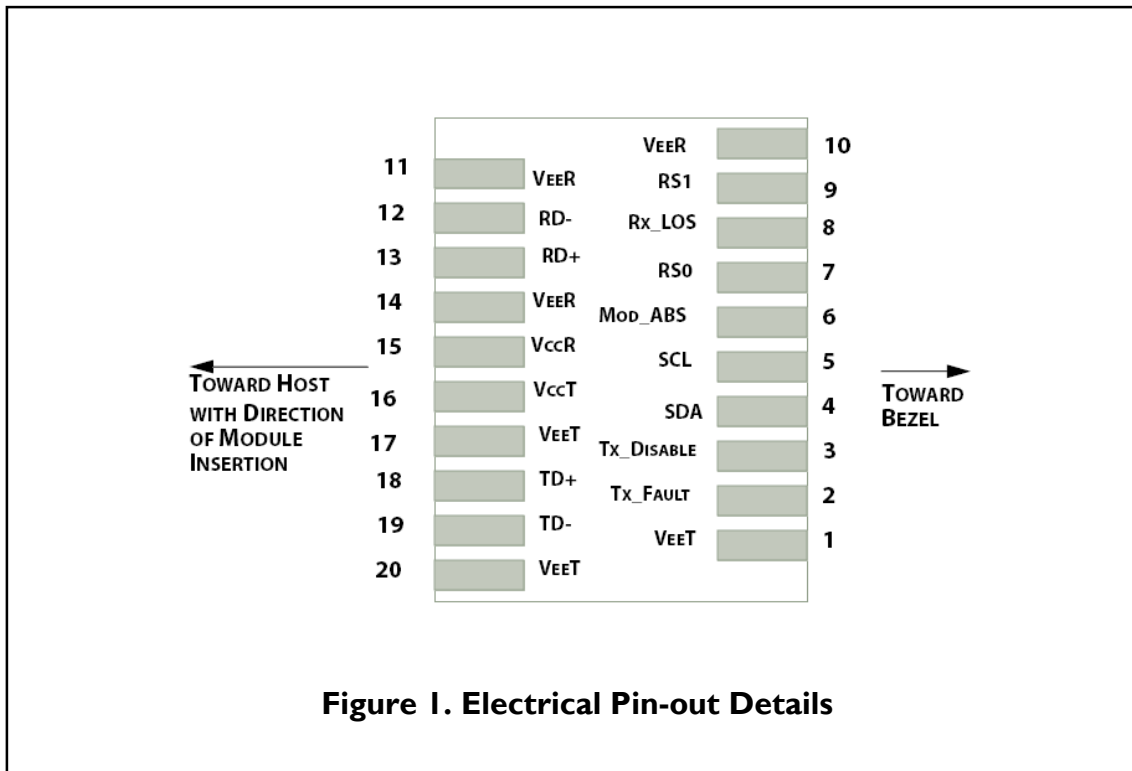

Figure 1. Electrical Pin-out Details

Pin	Symbol	Name/Description
1	VEET [1]	Transmitter Ground
2	Tx_FAULT [2]	Transmitter Fault
3	Tx_DIS [3]	Transmitter Disable. Laser output disabled on high or open
4	SDA [2]	2-wire Serial Interface Data Line
5	SCL [2]	2-wire Serial Interface Clock Line
6	MOD_ABS [4]	Module Absent. Grounded within the module
7	RS0 [5]	RS0 for Rate Select: Open or Low = Module supports $\leq 4.25$ Gbps High = Module supports 9.95 Gb/s to 10.3125 Gb/s
8	RX_LOS [2]	Loss of Signal indication. Logic 0 indicates normal operation
9	RS1 [5]	No connection required
10	VEER [1]	Receiver Ground
11	VEER [1]	Receiver Ground
12	RD-	Receiver Inverted DATA out. AC Coupled
13	RD+	Receiver DATA out. AC Coupled
14	VEER [1]	Receiver Ground
15	VCCR	Receiver Power Supply
16	VCCT	Transmitter Power Supply
17	VEET [1]	Transmitter Ground
18	TD+	Transmitter DATA in. AC Coupled
19	TD-	Transmitter Inverted DATA in. AC Coupled
20	VEET [1]	Transmitter Ground

**Notes:**

[1] Module circuit ground is isolated from module chassis ground within the module.

[2].should be pulled up with 4.7k – 10k ohms on host board to a voltage between 3.15V and 3.6V.

[3]Tx\_Disable is an input contact with a 4.7 k $\Omega$  to 10 k $\Omega$  pullup to VccT inside the module.

[4]Mod\_ABS is connected to VeeT or VeeR in the SFP+ module. The host may pull this contact up to Vcc\_Host with a resistor in the range 4.7 k $\Omega$  to 10 k $\Omega$ .Mod\_ABS is asserted “High” when the SFP+ module is physically absent from a host slot.

[5] RS0 and RS1 are module inputs and are pulled low to VeeT with > 30 k $\Omega$  resistors in the module.

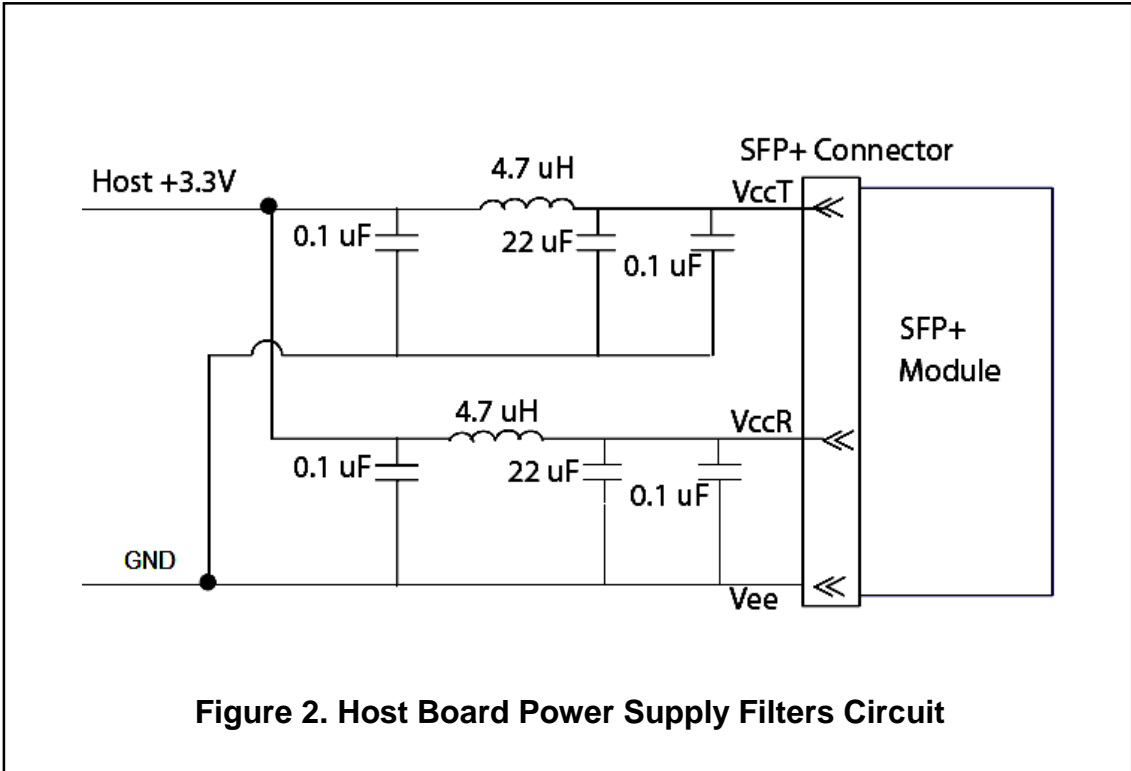
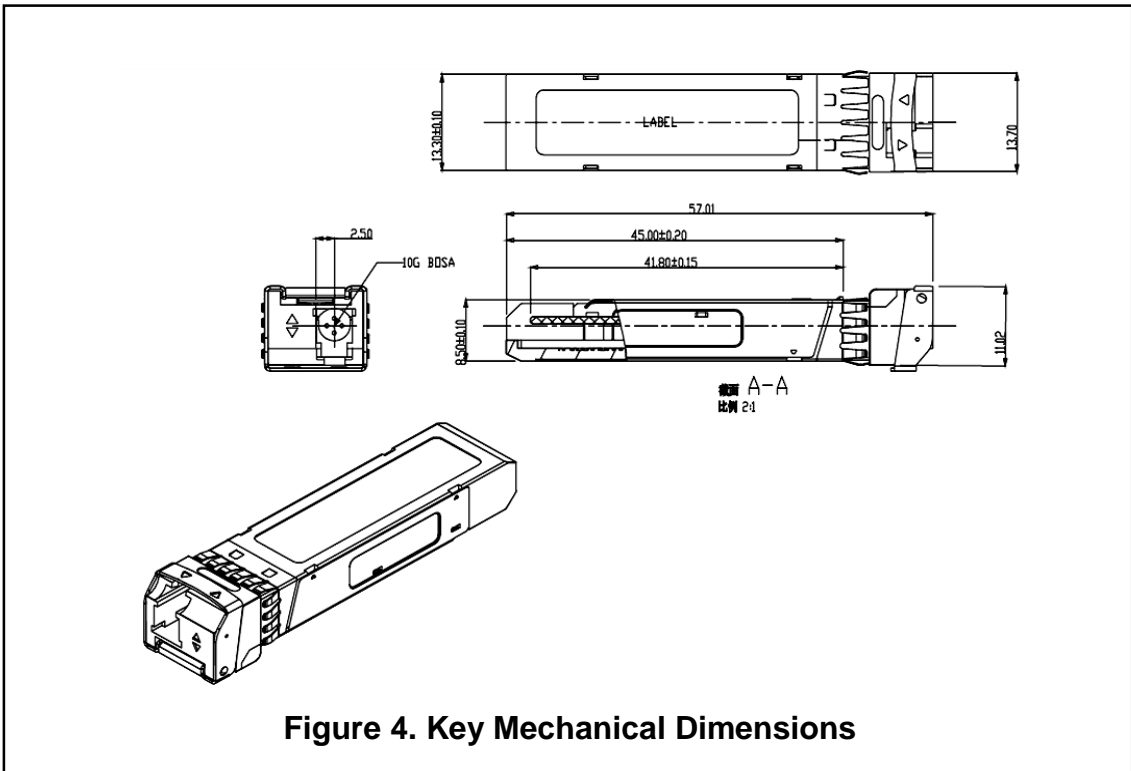
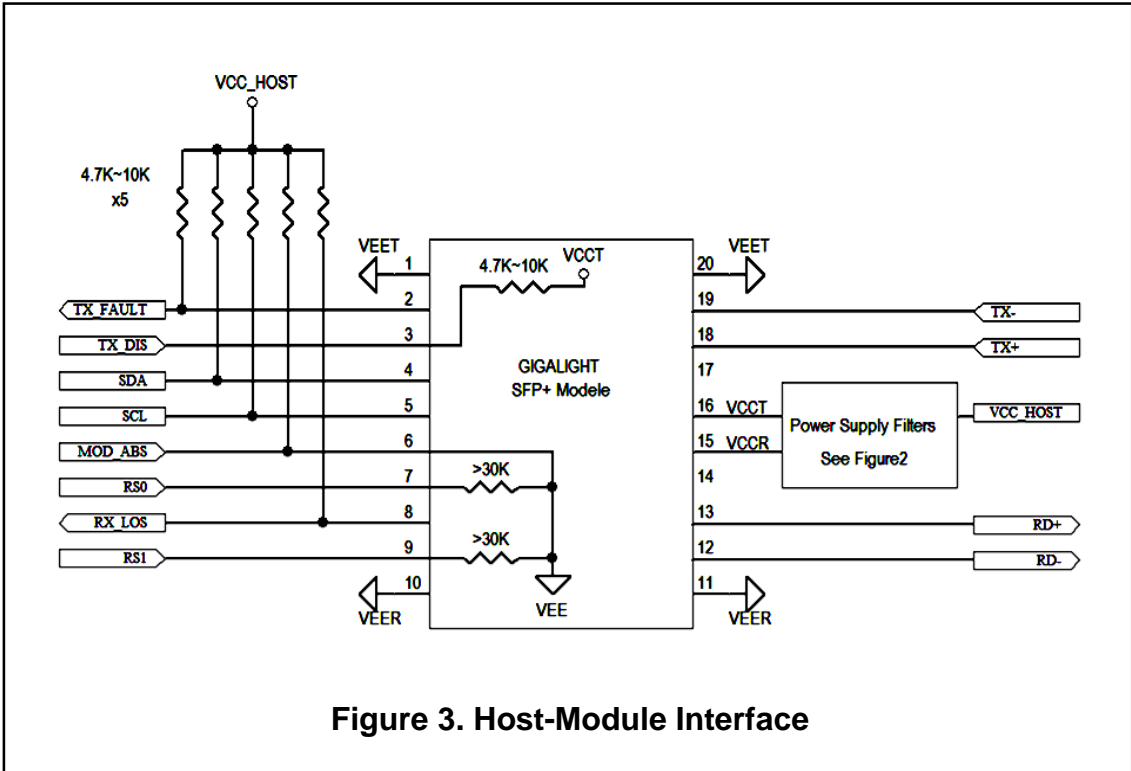

Figure 2. Host Board Power Supply Filters Circuit





## Ordering information

Part Number	Product Description
XTB23A-60LY	1270 nm/1330 nm, 10 Gbps, 60 km, 0° C ~ +70° C
XTB32A-60LY	1330 nm/1270 nm, 10 Gbps, 60 km, 0° C ~ +70° C

Notice. Please specify any compatibility requirements at time of ordering. Standard MSA compatible pluggable components may not work or some function of these components may not be available in devices that require customized compatible devices. Pluggable components compatible with one type of communications equipment may not work in other type of communications equipment.

## Important Notice

Performance figures, data and any illustrative material provided in this data sheet are typical and must be specifically confirmed in writing by Xenya before they become applicable to any particular order or contract. In accordance with the Xenya policy of continuous improvement specifications may change without notice.

The publication of information in this data sheet does not imply freedom from patent or other protective rights of Xenya or others. Further details are available from any Xenya sales representative.

E-mail: [info@xenia.si](mailto:info@xenia.si)

Web: [www.xenia.si](http://www.xenia.si)