



PCI RAID Controller

Installation Guide

DAC960PD-Ultra

DAC960PD

DAC960PL

DAC960P

P/N: 771960-D02



**DAC960PD-Ultra
DAC960PD
DAC960PL
DAC960P**

PCI RAID Controller Installation Guide

Part Number 771960-D02

© Copyright 1997 Mylex Corporation.
All Rights Reserved.

All contents of this manual are copyrighted by Mylex Corporation. The information contained herein is the exclusive property of Mylex Corporation and shall not be copied, transferred, photocopied, translated on paper, film, electronic media, or computer-readable form; or otherwise reproduced in any way, without the express written permission of Mylex Corporation.

Notice

Although reasonable efforts have been made to assure the accuracy of the information contained herein, this publication could include technical inaccuracies or typographical errors. Mylex Corporation expressly disclaims liability for any error in this information, and for damages, whether direct, indirect, special, exemplary, consequential or otherwise, that may result from such error, including but not limited to loss of profits resulting from the use or misuse of the manual or information contained therein (even if Mylex Corporation has been advised of the possibility of such damages). Any questions or comments regarding this document or its contents should be addressed to Mylex Corporation at the address shown on the cover.

The following paragraph does not apply to the United Kingdom or any country where such provisions are inconsistent with local law:

MYLEX CORPORATION PROVIDES THIS PUBLICATION "AS IS" WITHOUT WARRANTY OF ANY KIND, EITHER EXPRESS OR IMPLIED, INCLUDING, BUT NOT LIMITED TO, THE IMPLIED WARRANTIES OF MERCHANTABILITY OR FITNESS FOR A PARTICULAR PURPOSE.

Some states do not allow disclaimer of express or implied warranties or the limitation or exclusion of liability for indirect, special, exemplary, incidental or consequential damages in certain transactions; therefore, this statement may not apply to you. Also, you may have other rights which vary from jurisdiction to jurisdiction.

Information in this publication is subject to change without notice and does not represent a commitment on the part of Mylex Corporation. Changes may be made periodically to the information herein; these changes will be incorporated in new editions of the publication. Mylex Corporation reserves the right to make improvements and/or changes at any time in the product(s) and/or program(s) described in this publication.

It is possible that this publication may contain reference to, or information about, Mylex Corporation products (machines and programs), programming or services that are not announced in your country. Such references or information must not be construed to mean that Mylex Corporation intends to announce, provide, or make available such Mylex products, programming, or services in your jurisdiction.

Requests for technical information about Mylex Corporation products should be made to your Mylex authorized reseller or Mylex representative.

Mylex is a registered trademark and DAC960 is a trademark of Mylex Corporation.

IBM and IBM PC are registered trademarks of International Business Machines Corporation.

Intel and i960 are registered trademarks of Intel Corporation

Microsoft and MS-DOS are registered trademarks of Microsoft Corporation. Windows and Windows NT are trademarks of Microsoft Corporation.

Other names that are trademarks may be used herein for the purpose of identifying the products or services of their respective owners.

FC Class B Compliance

THIS DEVICE COMPLIES WITH PART 15 OF THE FCC RULES. OPERATION IS SUBJECT TO THE FOLLOWING TWO CONDITIONS:

1. THIS DEVICE MAY NOT CAUSE HARMFUL INTERFERENCE, AND
2. THIS DEVICE MUST ACCEPT ANY INTERFERENCE RECEIVED, INCLUDING INTERFERENCE THAT MAY CAUSE UNDESIRE OPERATION.

This equipment has been tested and found to comply with the limits for a Class B digital device, pursuant to Part 15 of the FCC rules. These limits are designed to provide reasonable protection against harmful interference in residential installations. This equipment generates, uses, and can radiate radio frequency energy, and if not installed and used in accordance with the instructions, may cause harmful interference to radio communications. However, there is no guarantee that interference will not occur in a particular installation.

If this equipment does cause interference to radio or television equipment reception, which can be determined by turning the equipment off and on, the user is encouraged to try to correct the interference by one or more of the following measures:

1. Reorient or relocate the receiving antenna
2. Move the equipment away from the receiver
3. Plug the equipment into anm outlet on a circuit different from that to which the receiver is powered.

If necessary, the user should consult the dealer or an experienced radio/television technician for additional suggestions.

All external connections should be made using shielded cables..

Caution

Only equipment certified to comply with Class B (computer input/output devices, terminals, printers, etc.) should be attached to this equipment.

Finally, any changes or modifications to the equipment by the user not expressly approved by the grantee or manufacturer could void the user's authority to operate such equipment.

FC Declaration of Conformity

Manufacturer's Name: Mylex Corporation
Manufacturer's Address: 34551 Ardenwood Blvd.
Fremont, CA 94555-3607
USA

Declares that the product:

Product Name: DAC960P Series RAID Controllers
Model Number(s): DAC960P, DAC960PL, DAC960PD,
DAC960PD-Ultra
Year of Manufacture: 1997

Conforms to the following Product Specification(s):

EMC: EN 50081-1:1992/EN 55022:1992 Class B
EN 50082-1:1992 - Generic Immunity

EN 61000-4-2:1995, 4kV CD, 8kV AD
EN 50140:1995, 3 V/m, 80 - 1000 MHz, 80%
EN 61000-4-4:1995, 0.5kV I/O, 1kV Power

Supplementary Information:

The product herewith complies with the requirements to the EMC Directive 89/336/EEC

Declaration that the equipment specified above conforms to the above directive(s) and standard(s) is on file and available for inspection at the manufacturer's address cited above.

Community of Europe

CE mark is rated for the DAC960P Series as follows:

CISPR 22 Radiated Emission

EN55022, EN5082-1 Generic immunity standard for the following:
IEC 801-2 ESD, IEC 801-3 Radiated, and IEC 801-4 EFT/Burst

Warning!

This is a Class B product. In a residential environment this product may cause radio interference, in which case the user may be required to take adequate measures.

Achtung!

Dieses ist ein Gerät der Funkstörgrenzwertklasse B. In Wohnbereichen können bei Betrieb dieses Gerätes Rundfunkstörungen auftreten, in welchen Fällen der Benutzer für entsprechende Gegenmaßnahmen verantwortlich ist.

Avertissement!

Cet appareil est un appareil de Classe B. Dans un environnement résidentiel cet appareil peut provoquer des brouillages radioélectriques. Dans ce cas, il peut être demandé à l'utilisateur de prendre des mesures appropriées.

About This Manual

This Installation Guide describes how to make the DAC960P Series PCI-to-SCSI Disk Array Controller ready to use. The chapters in this manual contain step-by-step instructions for performing the procedures necessary to:

- Set up and install the controller board and its options
- Configure and connect the SCSI drives

This manual is designed as a quick reference guide for the system administrator or experienced computer user who is familiar with the principals and conventions of the Peripheral Component Interface (PCI), the Small Computer System Interface (SCSI), and with Redundant Array of Independent Disks (RAID) technology.

Chapter 1 contains an overview the DAC960 PCI RAID Controller equipped with Firmware 3.x. Included are new features, options and specifications.

Chapter 2 provides block-diagram level description of the DAC960P Series and a description of its RAID and SCSI functionality.

Chapter 3 describes the installation, including the necessary requirements, a helpful quick-reference checklist, instructions for setting the SCSI termination jumpers prior to installation, along with the instructions for configuring the drives and installing the cables.

Chapter 4 describes the DAC960 BIOS startup sequences and provides troubleshooting reference material with the DAC960P Series Power-on self-test error messages.

Appendix A provides information about supported enclosure management schemes used to monitor enclosure fans, power supplies, and temperature.

At the successful conclusion of the procedures in this manual, the disk array system will be ready to:

- Configure and format the disk drives
- Define and initialize the logical units
- Receive the operating system, applications software, and data.

Refer to the *DACCF Utilities Installation and User Guide* for more information about configuring, initializing, and operating the DAC960P Series controllers.

Conventions

Throughout the manual, the following conventions are used to describe user interaction with the product:

- bold** The user must enter the bold text exactly as shown
- ↵ Press the Enter key
- Enter** Press the key labeled “Enter” (or “Delete”, etc.)
- File, Run** Select the Run option from the pull-down menu activated when the File menu pad is selected
- Note** Supplementary information that can have an effect on system performance
- Caution** Notification that a proscribed action has the *potential* to adversely affect equipment operation, system performance, or data integrity
- WARNING** Notification that a proscribed action will *definitely* result in equipment damage, data loss, or personal injury

Contents

Chapter 1

Introduction

DAC960 PCI RAID Product Description	1-1
Standard Package Contents	1-3
Options	1-3
User-Supplied Items	1-3
Controller Functions and Features	1-4
Key Features	1-4
New Features Introduced with Firmware 3.x	1-4
Configuration on Disk (COD)	1-4
Features Available with All Firmware Versions	1-4
RAID/SCSI Disk Array Management	1-5
Automatic RAID Functions	1-5
Enhance SCSI Performance	1-6
Increase System Availability	1-6
Operating System Support	1-6
Specifications	1-7

Chapter 2

Functional Description

Overview	2-1
Controller Components	2-2
The i960 Processor	2-2
Cache Memory Subsystem	2-2
Controller Firmware	2-2
PCI Bus Interface	2-3
Ultra SCSI Bus Interface	2-3
SCSI Bus Interface	2-4
Configuration on Disk	2-4
Management of Bad Data	2-4
Separate Disk-stripe Size and Cache-line Size	2-5
System Drive Size Extensions	2-5
Support for Additional Target IDs per Channel	2-5
Support for up to 32 System Drives per Controller	2-5
BIOS Enable/Disable	2-5
SCSI Functions	2-6
Multiple SCSI Format Support	2-6
SCSI Cabling and Termination Conventions	2-6
SCSI Address (Target ID) Selection	2-6

Drive Organization	2-8
Physical Drives (Drive Groups or Packs)	2-8
Logical Units (System Drives)	2-8
Configuration on Disk	2-9
RAID Management	2-11
RAID Techniques and Terms	2-12
JBOD (No RAID)	2-12
Mirroring (RAID 1)	2-13
Striping (RAID 0)	2-13
Stripe Width	2-14
Stripe Order	2-14
Stripe Size	2-14
Striping with Parity (RAID 5)	2-15
Drive Management	2-17
Controlling Physical Drive States	2-17
On-line (ONL)	2-17
Standby (SBY)	2-17
Dead (DED)	2-17
Write-Only (WOL)	2-18
Ready (RDY)	2-18
Controlling Logical Unit States	2-19
On-line	2-19
Critical	2-19
Off-line	2-19
Controlling Standby Replacement Drives (Hot Spares)	2-20
Using Standby Rebuild	2-20
Standby Replacement Table	2-20
Hot-Swap Drive Replacement	2-21
Disk Failure Detection	2-21
Disk Media Error Management	2-21
Checking Disk Parity	2-22
Cache Management	2-22
Read Cache	2-22
Write-Back Cache	2-22
Write-Through Cache	2-22
Cache Battery Backup	2-22

Chapter 3 Installation

Overview	3-1
Requirements	3-1
Optional Requirements	3-1
Before You Begin	3-2
INSTALLATION NOTES:	3-3
DAC960 PCI RAID Controller Installation Checklist	3-4
Connectors and Jumpers	3-5
External LED Connectors	3-7
AEMI Interface Connector	3-7
SCSI Termination	3-8
Terminating Internal Disk Arrays	3-8
Terminating External Disk Arrays	3-9
Terminating Combined Internal and External Disk Arrays	3-10
Selecting the Correct Terminator	3-10
Configuring the SCSI Devices	3-11
Setting Device Termination Power	3-11
Setting Drive Spin-up & Parity Jumpers	3-11
SCSI Cabling	3-12
Cable Lengths	3-13
Connecting Non-Disk Devices	3-14
Using a UPS	3-15
Cache Battery Backup Option	3-16
Battery Backup Module Connector	3-16

Chapter 4 Startup Sequences

Introduction	4-1
System Power-Up Sequence	4-1
BIOS Startup Sequence	4-2
Setting BIOS Options	4-2
Invoking the BIOS Options Menu	4-2
BIOS Enable or Disable	4-5
CD-ROM Boot Disable or Enable	4-5
Enable 8 GByte or 2 GByte Drives	4-6
Error Messages	4-6
Startup Error Messages	4-6
Drive Check Error Messages	4-7
Aborted Installation	4-8
NVRAM Error	4-8
System Reboot or Power Down	4-8

Appendix A
Enclosure Management

Introduction	A-1
SAF-TE	A-1
AEMI	A-2

Chapter 1

Introduction

DAC960 PCI RAID Product Description

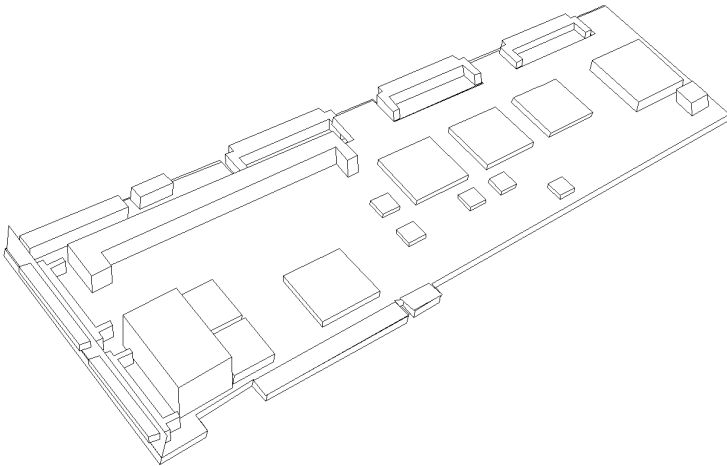

Figure 1-1. DAC960 PCI Three-channel RAID Controller

The Mylex DAC960 PCI RAID Controller is an intelligent, high-performance, advanced RAID controller for PCI-based mid-range to large servers, office management systems, or single-user desktop workstation computing environments.

The DAC960 PCI RAID controller supports industry-standard RAID levels (0, 1, 5, and 0+1), for multiple-drive arrays, or for single-drive control functionality. Set-up is by a simple to run software configuration utility (DACCF). The highly-intuitive graphic user interface software, Global Array Manager (GAM), provides RAID administration and management capabilities.

The DAC960 controller is available with either one, two, or three fully independent Fast/Wide SCSI channels for connecting SCSI hard drives or other non-disk SCSI devices, specifically CD-ROM and DAT tape drives.

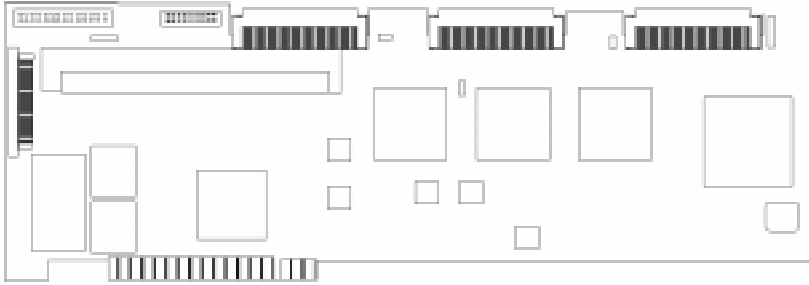

Figure 1-2. DAC960 Controller component layout

Connectors on the top edge of the DAC960 controller board provide the interface for internal SCSI devices. SCSI Channel 0 (and Channel 1 if installed) is also available on the end of the card for connecting to external disk array enclosures or other SCSI devices.

The DAC960 controller uses a 32-bit RISC-based microprocessor, ASIC logic arrays, and dedicated read/write cache memory to reduce the host system's CPU load and to increase disk I/O throughput (up to 120 MB/second on the 3 channel controller).

On-board memory required for operation is either a DRAM or EDRAM SIMM module (72 pin, 36-bit). DAC960 controllers equipped with EDRAM deliver enhanced performance through zero wait-state CPU/SIOP burst-cycle transfers between the DAC960 cache and the host system. The memory configuration on DAC960 controllers equipped with EDRAM may be either 4- or 8 MB (15 ns, 0 ws). DAC960 controllers equipped with DRAM may be configured with either 4-, 8-, 16-, or 32 MB (70ns or faster).

Standard Package Contents

- DAC960 PCI RAID Controller with cache memory (minimum 4 MB required for operation) and Installation Guide manual
- Configuration & Utilities software (DACCF 4.2 or greater) diskette and manual for controllers using firmware 3.x)
- DAC Software Kit (NOS driver software) diskettes and manual
- Global Array Manager (GUI software) diskettes and manual

Options

- Mylex DBB960P Battery Backup Unit (BBU) for the DAC960P/PD/PD-Ultra
- Mylex DBB960PL BBU for the DAC960PL

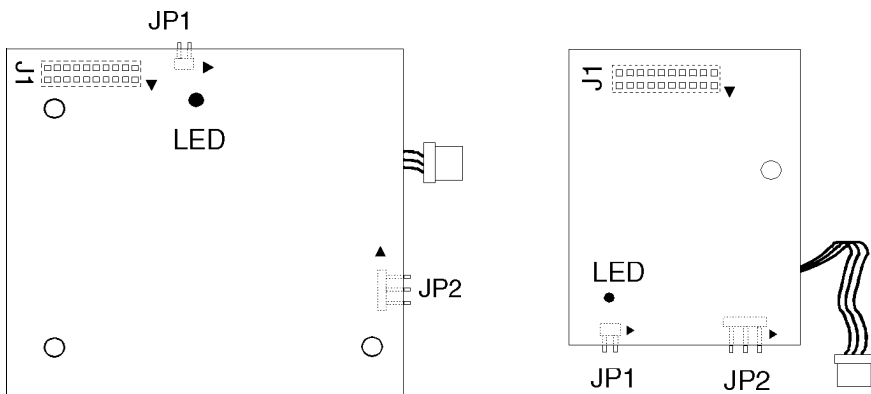

Figure 1-3. BBUs for DAC960P/PD/PD-Ultra (Left) and DAC960PL (Right)

User-Supplied Items

The following items may also be required, depending on the application:

- Cache memory upgrade (One 72-pin SIMM, $n \times 36$, – EDRAM: 8 MB, 15 ns; DRAM: 4, 8, 16, or 32 MB, 70 ns)
- SCSI cables (internal), one per channel
- Internal and/or external SCSI terminators, as required
- 68-pin to 50-pin SCSI Adapter (if required)
- External SCSI cables (if required)

Controller Functions and Features

Key Features

New Features Introduced with Firmware 3.x

- Support of up to 15 drives per channel, and up to 32 system drives (logical drives) on a controller
- Support for system drives with a capacity of up to 2 terabytes
- BIOS support for physical drives with a capacity of up to 8 gigabytes
- Management of bad data
- Separate disk-stripe size and cache-line size
- Configuration on disk (COD)

Configuration on Disk (COD)

Firmware 3.x introduces a Configuration on Disk (COD) feature. If the system is powered off and any of the following changes are made, the disks and controllers will automatically reconfigure when the system is restarted. Operator intervention is not needed, unless a major change such as RAID level, stripe size, or array size is made.

Any combination of the following changes can be performed.

1. Drives in an array can be removed and reinstalled in any order (target IDs can be switched within an array).
2. The drives' SCSI channel assignments can be changed.
3. A DAC960 controller can be exchanged with another DAC960 controller as long as both controllers have 3.x firmware.

Features Available with All Firmware Versions

- Complete RAID/SCSI disk array configuration and management
- Automatic rebuild after disk failure without user intervention
- SCSI performance enhancement for faster data transfers
- Automatic fault monitoring and recovery increases system availability
- Supports all major operating systems and network environments

RAID/SCSI Disk Array Management

- Supports multiple RAID levels (0, 1, 5, and 0 + 1) allowing user to select the desired combination of storage capacity, data availability (redundancy) and I/O transfer performance for any data application
- Connects up to 45 SCSI drives that can be grouped and managed as a single large-capacity logical drive (up to 2 TeraBytes), as multiple large-capacity drive groups, or as individual drives (with a maximum of 32 system drives)
- Up to four DAC960 controllers per host connect up to 180 SCSI devices
- Industry-standard Fast/Wide SCSI-2 interface supports most SCSI drives

Automatic RAID Functions

- Automatic failed-drive detection
- Automatic rebuild of the array using stand-by (hot spare) disk after a drive failure
- Transparent drive rebuild permits automatic rebuild of failed drives during normal operation without having to take the array off-line
- Automatic error detection/correction of parity errors, bad blocks, etc.
- Automatic sector remapping recovers defective media and corrects data errors

Enhance SCSI Performance

- Fast/Wide SCSI and Ultra SCSI channels provide high-performance data transfers at up to 40 MB/second/channel
- PCI bus mastering provides up to 132 MB/second burst data rates
- Tag-queuing to the host allows processing of up to 64 simultaneous multi-thread system commands or data requests
- User-defined performance-tuning through selectable cache write policy, variable stripe width, and rebuild priority to optimize controller performance during rebuild
- Disconnect/reconnect capability for enhanced performance and SCSI bus optimization

Increase System Availability

- Built-in diagnostics provide controller and drive fault monitoring during-power-on and continuous operation
- Status alerts notify the administrator or user of critical conditions
- Supports SCSI Accessed Fault-Tolerant Enclosures (SAF-TE) protocol for integrated monitoring of enclosure power supplies, fans, and temperature
- Supports Array Enclosure Management Interface (AEMI) protocol for integrated monitoring of enclosure power supplies, fans, and temperature
- Battery backup option protects data in the controller cache in the event of a power interruption

Operating System Support

- Novell NetWare 3.1x, 4.0x, 4.1x
- Microsoft Windows NT 3.5x and Advanced Server
- IBM OS/2 2.1, 2.2, 3.0 (WARP), SMP
- SCO UNIX 3.2.4 and SCO ODT
- Novell UnixWare v2.0
- Banyan Vines 6.x
- MS-DOS 5.x, 6.x, and above
- Microsoft Windows 95
- Microsoft Windows 3.x

Specifications

Controller

DAC960 PCI RAID Controller

CPU

DAC960P/PD/PD-Ultra:

Intel i960CFÆ RISC 32-bit microprocessor

DAC960PL:

Intel i960JFÆ RISC 32-bit microprocessor

Memory

DAC960P/PD/PD-Ultra:

Module Type

DRAM or EDRAM, 72-pin SIMM

Size

Minimum : 4 MB DRAM, 70ns or faster

4 MB EDRAM, 15ns (0 ws)

Optional: DRAM, 4, 8, 16, or 32 MB ($n \times 36$)

EDRAM, 8 MB ($n \times 36$)

DAC960PL:

Module Type

DRAM, 72-pin SIMM

Size

Minimum : 4 MB, 70ns or faster

Optional: 4, 8, 16, or 32 MB ($n \times 36$)

Cache Type:

Write:

Selectable, Write Through or Write Back

Read:

Always enabled

Firmware

ROM Type

Flash EEPROM, 2 - 128K x 8; boot sector

BIOS

Executed from DRAM (Shadow RAM)

PCI

I/O Processor

Mylex 189206 ASIC

Bus Type

32-bit, 33 MHz, PCI Local Bus

Mode

Bus Master

Transfer Rate

Up to 132 MB/second (burst)

SCSI

I/O Processors

DAC960PD-Ultra:

Symbios Logic 53C770Æ, one per channel

DAC960P/PD/PL:

Symbios Logic 53C720Æ, one per channel

Specifications (continued)

SCSI Bus Type

DAC960PD-Ultra:

	8 or 16-bit Ultra SCSI compliant
Transfer rate	Up to 40 MB/second per channel Up to 120 MB/second, 3 channels

DAC960P/PD/PL:

	8 or 16-bit Fast / Wide SCSI-2 compliant
Transfer rate	Up to 20 MB/second per channel Up to 60 MB/second, 3 channels

RAID

Levels supported	RAID 0, Striping RAID 1, Mirroring RAID 5, Parity RAID 0 + 1, Striping and Mirroring JBOD, Single-drive control
------------------	---

Electrical requirements

Input Power	5V \pm 5% @ 2.5 Amp ¹ (w/4MB memory) 5V \pm 5% @ 3.5 Amp ¹ (w/16MB memory) 1 (Supply currents assume drives providing term power)
-------------	---

Environmental

Temperature	Operating:	5°C to 55°C
	Storage:	-60°C to +150°C
Humidity (non-condensing)	Operating:	20% to 90% rh
	Non-operating	20% to 90% rh

Dimensions

Length	12.5 inches
Height	4.19 inches

Chapter 2

Functional Description

Overview

The Mylex DAC960 PCI RAID controllers provide high-performance PCI-to-SCSI disk array control functionality for medium-size to large network servers or workstations. When properly configured, the DAC960 delivers a high degree of fault tolerance and advanced disk array management features through the use of RAID technology.

The DAC960 PCI RAID controller plugs into one of the host system's Peripheral Component Interface (PCI) bus slots and connects to either internal disk drives and/or external drive enclosures via standard SCSI-2 or Ultra-SCSI compliant cabling.

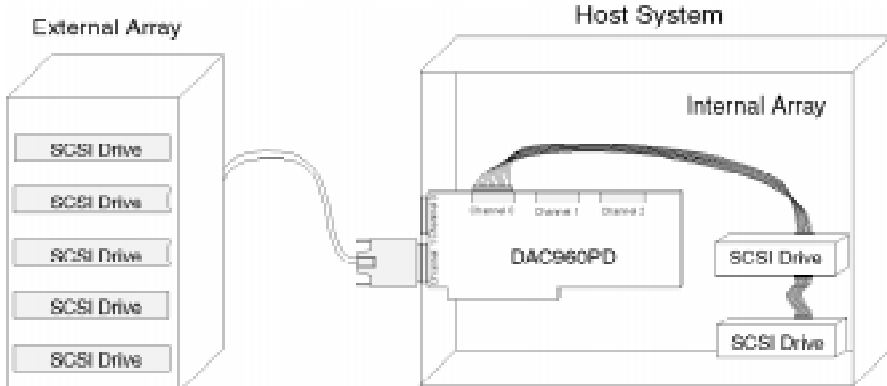

Figure 2-1. System Diagram

Controller Components

Key components of the DAC960 PCI RAID controller (see Figure 2-2) are:

- i960 RISC processor
- Cache Memory and Memory Control Unit
- PCI and SCSI I/O subsystems

The i960 Processor

The DAC960 controller CPU is a 32-bit Intel i960 RISC microprocessor. The CPU controls all functions of the DAC960, including bus transfers, RAID processing, and it off-loads functions from the host's CPU.

Cache Memory Subsystem

The DAC960 can be configured with up to 32 megabytes of cache memory, depending on the type of SIMM modules being used. A minimum of 4 MB cache is required for controller operation. Cache write policy is user-selectable for each logical unit in the configuration.

A fast 32-bit interface is provided between the i960 CPU and the cache. In addition to memory control and addressing functions, this interface provides the device mapping and decode for the non-volatile memory (NVRAM) and the electronically-erasable/programmable read-only memory (Flash EEPROM). The MCU also detects the type of SIMM module installed and automatically sets the wait-state to either zero or one.

Controller Firmware

The DAC960 firmware contains the programs executed by the i960 CPU. The firmware resides in the on-board Flash EEPROM (2 modules required for Firmware 3.x) and operates through the Shadow RAM area of the controller. The EEPROM retains information after power is off and can also be re-written, to allow the controller firmware to be upgraded without the need to replace any hardware chips.

The NVRAM stores data on the current configuration of the controller and its attached disk drives, and lists of pending write operations issued to any redundant drives. As the configurations change (for example, when a drive fails), the NVRAM keeps a record of the changes. These data are checksum protected so that after a power failure, the controller will recall the configuration and will restore consistency for all outstanding writes on restart.

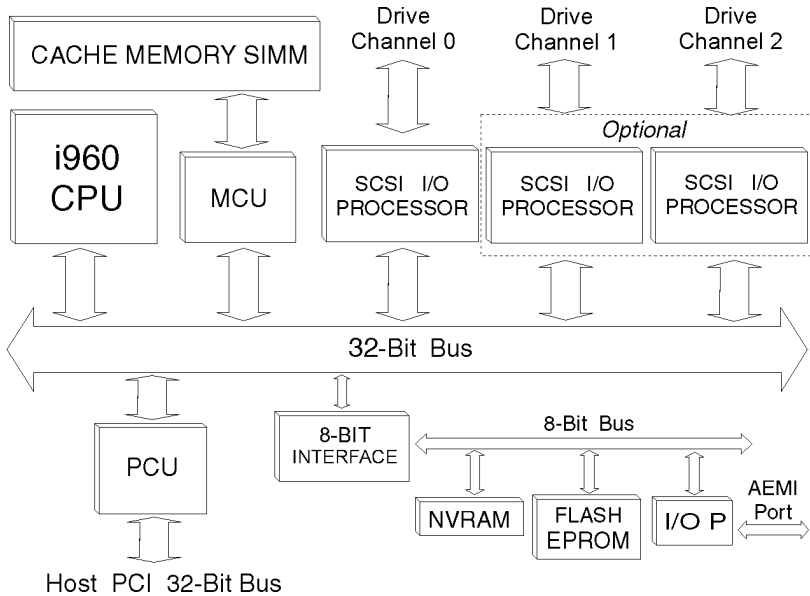

Figure 2-2. DAC960P Series Controller Block Diagram

PCI Bus Interface

The interface between the host system PCI bus and the i960 processor on the DAC960P Series is controlled in hardware by the Mylex 189206 PCU ASIC. The PCU provides fast data transfers without the limitations associated with PCI bridge technology. Interface to the host is by 32-bit, 33Mhz PCI local bus, using the single interrupt line, INTA#. Through PCI Bus Mastering, the DAC960 supports burst data transfers up to 132 MB/second.

Ultra SCSI Bus Interface

The DAC960PD-Ultra uses the Symbios Logic 53C770 enhanced performance Ultra-SCSI I/O processor chip on each SCSI channel to allow the controller to simultaneously read or write data on up to seven disk drives per channel. The DAC960PD-Ultra supports Ultra-SCSI standards as well as the Fast/Wide (8/16-bit) SCSI-2 standard, which is backward compatible with earlier SCSI standards. The DAC960PD-Ultra delivers SCSI data transfer rates up to 40 MB per second per channel (120 MB/sec 3-channel).

SCSI Bus Interface

The DAC960P/PD/PL use the Symbios Logic 53C720 enhanced performance SCSI I/O processor chip on each SCSI channel to allow the controller to simultaneously read or write data on up to 15 disk drives per channel. The DAC960 supports the Fast/Wide (8/16-bit) SCSI-2 standard, which is backward compatible with earlier SCSI standards. The DAC960 delivers SCSI data transfer rates up to 20 MB per second per channel (60 MB/sec 3-channel).

Configuration on Disk

Firmware 3.x provides Configuration on Disk (COD). COD allows a RAID equipped computer to detect certain hardware changes when they occur, and automatically reconfigure accordingly. Automatic reconfiguration occurs after hardware changes such as:

- Change of controller card in the event of a controller failure, or if a controller with more channels is needed.
- Change of target IDs (relocating drives) or replacement of drives
- Interchange of cables
- A drive failure that occurs during a power down

The configuration information is stored in the controller NVRAM and in the last 128 sectors of every working physical hard disk. This is transparent to the operating system.

Management of Bad Data

Firmware 3.x supports the handling of data that cannot be reconstructed at the time of a rebuild. A Bad Data Table is maintained in memory. Whenever a change is made to the table, the table is saved on all disks in the configuration.

Subsequent read operations check the Bad Data Table to determine whether any of the blocks about to be read are bad data blocks. If this is the case, an error condition is returned.

Subsequent write operations check the Bad Data Table to determine whether any of the blocks about to be overwritten are bad data blocks. If this is the case, the blocks are deleted from the Bad Data Table and the data is written to the disk.

Separate Disk-stripe Size and Cache-line Size

Firmware 3.x supports the configuration of disk-stripe sizing and cache-line sizing independently. This allows the user a certain degree of flexibility in adjusting performance. This can be set using the DACCF utility version 4.2 or greater.

System Drive Size Extensions

Firmware 3.x supports system disk drive sizes of up to 2 TeraBytes (32-bit sector number). Individual disk drives of up to 8GB are supported, without the need for additional drivers.

Support for Additional Target IDs per Channel

Firmware 3.x supports up to 15 target IDs per channel. The IDs must range from 0-6, and 8-15. Target ID 7 on each channel is reserved for the controller.

Support for up to 32 System Drives per Controller

Firmware 3.x supports up to 32 system drives that can be configured on up to 45 physical drives per controller (assuming the controller has three channels).

BIOS Enable/Disable

Firmware 3.x supports an option to enable or disable the BIOS that is stored in the DAC960 firmware. Disabling the BIOS prevents the DAC960 from being the boot controller. This and other BIOS options are discussed in detail in Chapter 4.

SCSI Functions

The DAC960P Series i960 RISC processor and SCSI I/O processor(s), provide intelligent, high-performance SCSI interface and control. The DAC960P Series manages and controls the SCSI bus arbitration between the controller and its connected devices, and all SCSI activity of the connected devices.

Multiple SCSI Format Support

The standard DAC960P Series provides at least one, and optionally up to three, SCSI channels for connecting disk drives or other devices, such as CD-ROM and tape drives. With the correct cabling, these devices may be any combination of Narrow, Fast, or Fast/Wide SCSI or Ultra-SCSI formats (see Table 2-1).

SCSI Cabling and Termination Conventions

Disk drives equipped with a SCSI interface should be connected to the controller by means of cables that comply with standard SCSI data-rate, pinout, and cable-length conventions (including all internal wiring). Up to 15 SCSI devices can be connected to each of the controller's drive channels. The first and last device on each channel must be terminated. The DAC960P Series supports active termination (sometimes designated as alternative-2, or ALT-2).

SCSI Address (Target ID) Selection

Each drive or device on a specific SCSI channel must be configured for a target address (or target ID) that is different from all other devices on that channel. The target ID, a SCSI address number from 0 to 15, is assigned to each device attached to a SCSI channel during installation. Target ID 7 is reserved for the DAC960 on each channel, and therefore must not be assigned to a device.

Table 2-1. Supported SCSI Formats

Controller	SCSI Type	Clock Rate	Data Rate
DAC960PD-Ultra (only)	Ultra-SCSI (16-bit)	20 Mhz	40 MB/sec
	Ultra-SCSI (8-bit)	20 Mhz	20 MB/sec
DAC960PD-Ultra, DAC960P/PD/PL	Wide SCSI-2 (16-bit)	10 Mhz 5 Mhz	20 MB/sec 10 MB/sec
	Narrow SCSI-2 (8-bit)	10 Mhz 5 Mhz	10 MB/sec 5 MB/sec
	SCSI-1 (8-bit)	5Mhz	5MB/sec

Drive Organization

The DAC960P Series controller organizes the SCSI drives connected to it as physical drives and logical units.

Physical Drives (Drive Groups or Packs)

Using the DAC960P Series, up to eight individual disk drives can be used together to form a pack or *drive group* of physical drives that will be used to comprise the array's logical unit capacity.

Note: If all of the disks in a drive group are not the same size, the drive group has the effective capacity of the multiple of the smallest drive.

To determine the total size of a drive group, multiply the size of the smallest drive in the drive group by the number of disk drives in the group.

For example, if there are four drives of 4 GB each, and one drive of 2 GB comprising a drive group, the effective capacity available for use is 10 GB (5 x 2), *not* 18 GB.

The DAC960P Series supports up to eight (8) drive groups.

Logical Units (System Drives)

A logical unit (or system drive) is that portion of a drive group (or a combination of up to eight drive groups) seen by the host system as a single logical device. The maximum addressable size of a single logical unit is 2 TB.

Each logical unit is identified to the host by its logical unit number (LUN). The DAC960P Series supports up to eight (8) LUNs per drive group. For example, on the first channel of the controller, the third logical unit having a SCSI target ID of 1 will be seen by the host computer as CH 0, ID 1, LUN 2 (since LUN numbering begins at 0, and continues 1, 2, 3, etc.).

Note: Use the DACC software utility to configure the logical units (system drives).

Configuration on Disk

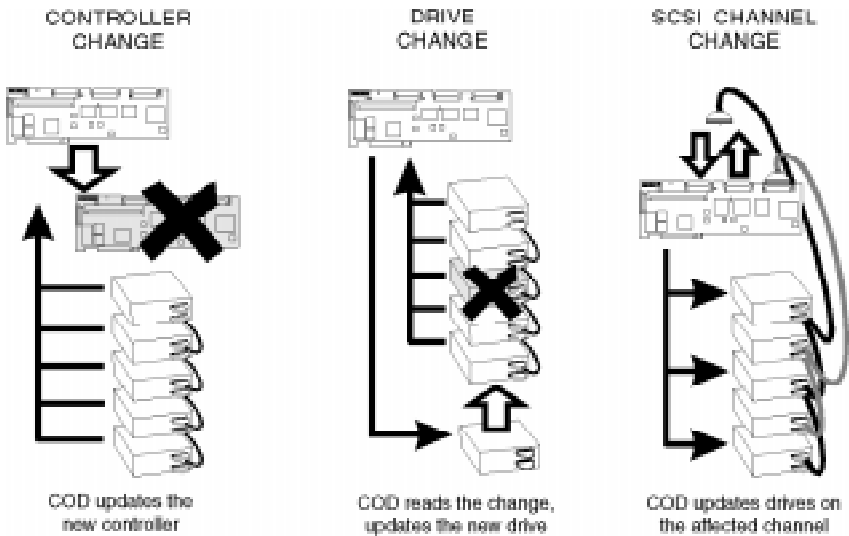

Figure 2-3. Configuration on Disk examples

Firmware 3.x provides Configuration on Disk (COD), which allows a RAID equipped computer to detect certain hardware changes when they occur and automatically reconfigure accordingly.

The necessary configuration information is stored on the controller as well as on every hard disk that is currently part of the controller's configuration. On startup, the configuration information is read from the controller. This information is used to scan and detect all physically connected and responding drives. The result is compared with the reference configuration stored on the controller. If a configuration matches, it is selected for use.

If there is a mismatch, the unidentified device is assumed to be new. If all drives connected to the controller are unidentified, the entire configuration is assumed to be new, and the DACCF utility needs to be invoked.

The selected configuration becomes the basis for a device translation table. This table is generated during the verification scan. Configuration headers are read at this time to determine if any drive slot (target ID) changes, cable swaps, or controller changes have occurred since the last verification scan.

At this time it is also determined whether or not any drives are missing. An attempt is made to map any missing drive to its original slot.

If a legal configuration cannot be created, an installation abort condition occurs, and the DAC configuration utility needs to be invoked. For more information, refer to the *DACCF Utilities Installation Guide and User Manual*.

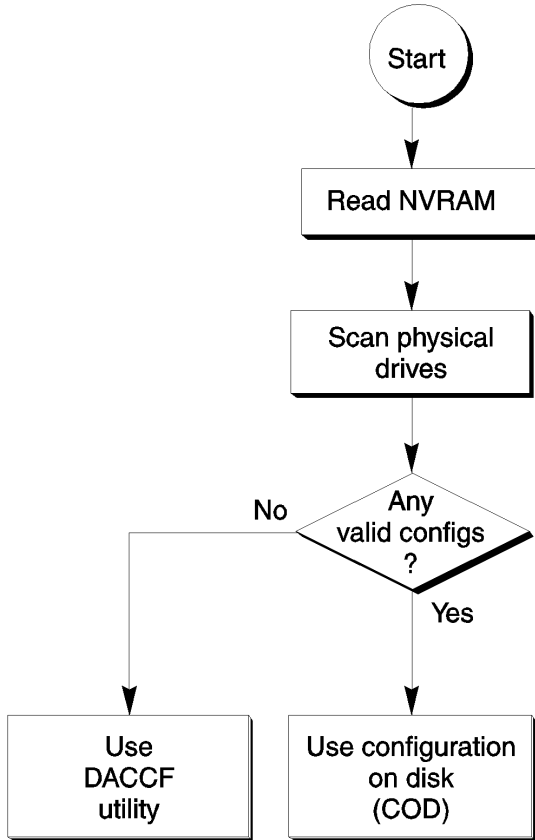

Figure 2-4. Configuration on Disk Flowchart

RAID Management

RAID is an acronym for Redundant Array of Independent Disks. The DAC960P Series controller implements several different versions of the Berkeley RAID technology, and two special versions that are specific only to the DAC960 family of RAID controllers. Each version (referred to as a RAID Level) that is supported by the DAC960P Series controller is shown in Table 2-2.

An appropriate RAID level is selected when the logical drives are defined or *created* using the configuration software utility (e.g., DACCF). Deciding which RAID level to use is based on the following priorities:

- Disk capacity
- Data availability (fault tolerance or redundancy)
- Disk performance

The DAC960P Series controller makes the RAID implementation and the disks' physical configuration transparent to the host operating system. This means that the host operating system drivers and software utilities are not affected, regardless of the RAID level selected.

Correct installation of the disk array and the DAC960P Series controller requires a proper understanding of RAID technology and the concepts described in this chapter and in the DACCF Utilities documentation.

Table 2-2. Supported RAID Levels

RAID Level	Description	Drives/Chnl	
		Min	Max
0	Block striping is provided, which yields higher performance than with individual drives. There is no redundancy.	2	8
1	Drives are paired and mirrored. All data is 100% duplicated on an equivalent drive (fully redundant).	2	2
5	Data is striped across several physical drives. Parity protection is used for data redundancy.	3	8
0+1	(Mylex RAID 6) Combination of RAID levels 0 and 1. This level provides striping and redundancy through mirroring.	3	8
JBOD	(Mylex RAID 7) "Just a Bunch of Drives." Each drive can operate independently as with a common host bus adapter; or multiple drives may be spanned and seen as a single very large drive. No redundancy is provided.	1	1

RAID Techniques and Terms

The techniques of disk striping, mirroring, and parity (redundancy) are fundamental elements of RAID technology performed by the DAC960 PCI RAID controller. More detailed information on how to apply these techniques can be found in the *DACCF Utilities* manual.

JBOD (No RAID)

JBOD is an acronym for Just a Bunch Of Disks. The disks function independently of one another, just as they would on a non-RAID SCSI controller.

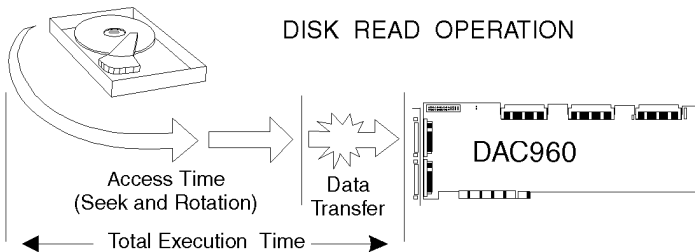

Figure 2-5. Typical JBOD Disk I/O Activity

Mirroring (RAID 1)

Mirroring refers to the 100% duplication of data from one disk drive onto another. Each disk contains the mirror image of the data on the other drive.

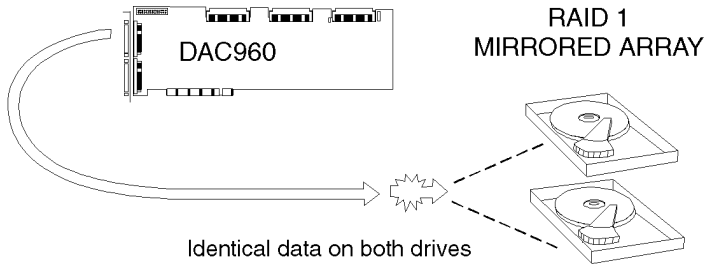

Figure 2-6. A Mirrored Drive Group

Striping (RAID 0)

Striping refers to the storing of a sequential block of incoming data across multiple drives in a drive group. For example, in a drive group (or pack) consisting of three drives mapped for striping, the data is separated into blocks with block one stored on drive zero, block two on drive one, block three on drive two. Drive zero will again be the location of the next block (block four); then, block five is stored on drive one, block six on drive two, and so on. This method can significantly increase disk system throughput, particularly for transferring large, sequential data blocks.

DRIVE 0	DRIVE 1	DRIVE 2
Block 0	Block 1	Block 2
Block 3	Block 4	Block 5
Block 6	Block 7	Block 8
Block 9	Block 10	Block 11
Block 12	Block 13	Block 14
Block n	Block n+1	Block n+2

Figure 2-7. Block Striping

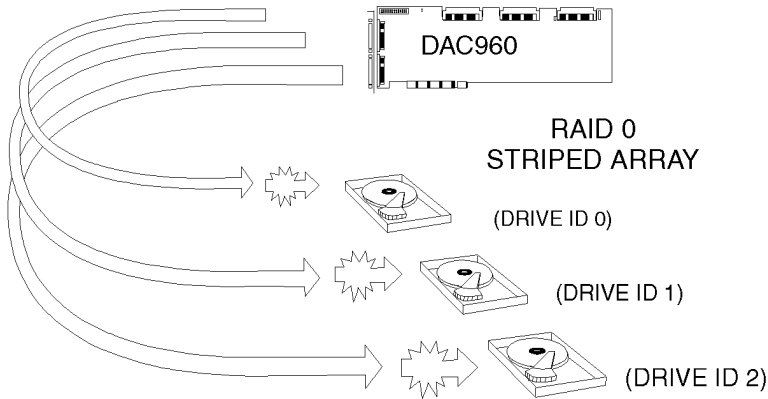

Figure 2-8. Drive Group Mapped for Block Striping

Stripe Width

The number of drives within a drive group is referred to as the stripe width.

Stripe Order

The order in which SCSI drives appear within a drive group is the *stripe order*. It is critical that the selected stripe order is always maintained, to assure data integrity and the controller's ability to rebuild failed drives.

Stripe Size

The size of the logically contiguous data block recorded on all drives connected to the controller is the stripe size. The default is 8 KB. Other choices are 16, 32 or 64 KB, which may be selected with the DACCF configuration utility (Advanced Functions menu, *Physical Parameters* option).

Larger stripe size ensures better performance for large sequential data transfers. Smaller stripe size is best suited for small random data transfers.

Striping with Parity (RAID 5)

Striping with parity (rotated XOR redundancy) is a method of providing complete data redundancy that requires only a fraction of the storage capacity for storing redundant information than does mirroring (XOR refers to the Boolean "Exclusive-OR" operator).

In a system configured under RAID-5 (which requires at least three SCSI drives, and typically five), all data and parity blocks are divided between the drives in such a way that if any single drive is removed (or fails), data on the missing drive can be regenerated using the data and parity information on the remaining drives.

Parity information is distributed across all the drives in the Drive Group, as is the data. Two drives are involved in each write operation (the target drive and the parity drive), while a read operation involves only one drive.

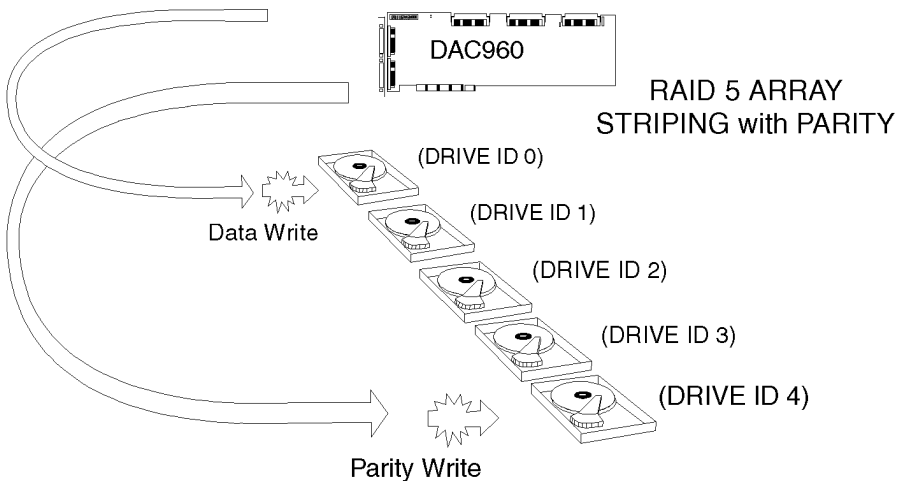

Figure 2-9. Drive Group Mapped for Block Striping with Parity

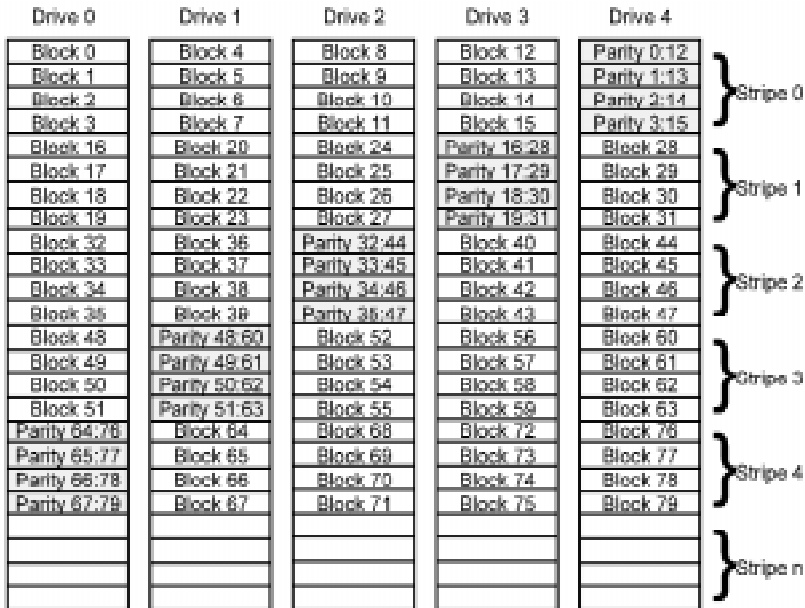

Figure 2-10. Block Striping with Parity

Performance for a RAID 5 array is influenced by the number of blocks in each stripe. The example illustrated by Figure 2-9 shows only four blocks per stripe. Typically, the stripe size would be much larger (32 Kbytes, or 64 blocks) to help ensure optimum write performance.

Because it excels in handling multiple transactions, RAID 5 is best suited for applications with small data blocks and high I/O request rates, such as multiple user databases and on-line transaction processing.

Drive Management

The DAC960P Series functions that monitor and control the operation of the physical drives and logical units are instrumental to the controller's ability to perform RAID management and automated error recovery tasks.

Controlling Physical Drive States

The *state* of a physical drive refers to a SCSI drive's current operational status. At any given time, a SCSI drive can be in one of several states: ON-LINE, STANDBY, READY, DEAD, REBUILD, or WRITE-ONLY.

The controller stores the state of the attached SCSI drives in its non-volatile memory. This information is retained even after power-off. If a SCSI disk is labeled DEAD in one session, it will stay in the dead state until a change is made either by using a system level utility or after a maintenance/rebuild procedure is performed.

On-line (ONL)

A SCSI drive (physical drive) is *on-line* if it:

1. Is powered on
2. Has been defined as a member of a drive group
3. Is operating properly.

Standby (SBY)

A SCSI disk drive is in a *standby* state if it:

1. Is powered on
2. Is able to operate properly
3. Has *not* been defined as part of any drive group.
4. Has been defined as a standby

Dead (DED)

A drive is *dead* if it:

1. Is not present
2. Is present, but not powered on
3. Failed to operate properly and was killed by the controller

When the controller detects a failure on a disk, it *kills* that disk by changing its state to dead. A SCSI drive that is in the dead state does not participate in any I/O activity. No commands are issued to dead drives.

Write-Only (WOL)

A SCSI drive is in a *write-only* state if it was in the process of being rebuilt, that is ...

- During a RAID 1 rebuild process, data is copied from the mirrored drive to the replacement drive.
- During a RAID 5 or RAID 0+1 rebuild, data is regenerated via the XOR redundancy algorithm and written to the replacement drive.

... and the rebuild was terminated abnormally before it completed.

Ready (RDY)

A SCSI disk drive may be identified by the DACCF utility as *ready* if it:

1. Is powered on
2. Is able to operate properly
3. Has *not* been defined as part of any drive group.
4. Has *not* been defined as a standby

Ready is not an actual drive state or command issued by the controller. The drive will change from RDY to SBY (standby) when the configuration is saved to memory.

Controlling Logical Unit States

The state of a DAC960 logical unit can be ON-LINE, CRITICAL, or OFF-LINE. Notice that the same term *on-line* is used for both physical drives and logical units.

Note: I/O operations can be performed only with logical units that are either *on-line* or *critical*.

On-line

A logical unit is *on-line* if all of its participating physical drives are on-line.

Critical

A logical unit is considered *critical* when any failure of another of its physical drives may result in a loss of data.

A logical unit is *critical* if it meets both of the following conditions:

1. It is configured for RAID 1, RAID 5 or RAID 0+1
2. One (and no more than one) of its physical drives is *not* on-line (refer to the description of *Off-line*, below).

Off-line

An *off-line* logical unit is one on which no data can be read or written. No operations can be performed on off-line logical units. System commands issued to off-line logical units are returned with an error status.

A logical unit can be off-line under one of two conditions:

1. It is configured with a redundant RAID level (1, 5, or 0+1) and two or more of its SCSI drives are *not* on-line
2. It is configured as RAID 0 or JBOD (or in a spanned set) and one or more of its SCSI drives are *not* on-line.

Controlling Standby Replacement Drives (Hot Spares)

The *standby replacement* drive, or *hot spare*, is one of the most important features the DAC960 controller provides to achieve automatic, non-stop service with a high degree of fault-tolerance. With the standby rebuild function, the controller performs a rebuild operation automatically when a SCSI disk drive fails and both of the following conditions are true:

1. A standby SCSI disk drive of identical or larger size is found attached to the same controller;
2. All of the system drives that are dependent on the failed disk are redundant system drives, e.g., RAID 1, RAID 5, or RAID 0+1.

During the automatic rebuild process, system activity continues as normal. System performance may degrade slightly, however, during a rebuild.

Using Standby Rebuild

To use the automatic standby rebuild feature, it is necessary to always maintain a standby disk in the system.

A *standby* disk can be created in one of the following ways:

1. When the DAC960 configuration is created or changed using the DACCF software utility, all disks attached to the controller that are *On-line* and not assigned to a drive group will be automatically labeled as standby disks.
2. A disk that is not part of any drive group may be made a standby drive by using the DOS-based DAC960 Toolkit utility, *DAC960TK.EXE*.

Standby Replacement Table

A standby replacement table stores data on up to eight automatic replacement events in any session (from one power-on/reset to the next power-off/ reset). When the limit of eight is reached and a disk failure occurs, a standby replacement can take place but is not recorded in the replacement table.

The standby replacement table can be cleared from the DAC960 by using the DACCF software utility *Save Configuration* command under either the New Configuration command or the View/Update Configuration command, System Drive Definition menu.

Hot-Swap Drive Replacement

The DAC960 PCI RAID controller supports the ability of certain drive enclosures to perform a *hot-swap* drive replacement while the system is on-line. A disk can be disconnected, removed, or replaced with a different disk without taking the system off-line. The SCSI bus termination must be arranged so that a drive can be removed without disrupting the termination scheme.

Disk Failure Detection

The DAC960 PCI RAID controller automatically detects SCSI disk failures. A monitoring process running on the controller checks, among other things, elapsed time on all commands issued to disks. A time-out will cause the disk to be reset and the command will be retried. If the command time-out occurs again, the disk could be killed by the controller (that is, its state changed to dead).

The DAC960 controller also monitors SCSI bus parity errors and other potential problems. Any disk with too many errors will be killed by the controller.

Disk Media Error Management

The DAC960 controller manages SCSI disk media errors in a manner transparent to the user.

Disks are programmed to report errors. When a disk reports a media error during a read, the controller reads the data from the mirror (RAID 1 or RAID 0+1), or computes the data from the other blocks (RAID 5), and writes the data back to the disk that encountered the error. If the *write* fails, or the following *verify-of-data* fails (media error on write), the controller issues a REASSIGN command to the disk, and then writes the data to a new location. Since the problem has been resolved, no error is reported to the system.

When a disk reports a media error during a write, the controller issues a REASSIGN command to the disk, and writes the data out to a new location on the disk.

Checking Disk Parity

A parity check is a process that verifies the integrity of redundant data. For example, performing a parity check of a mirrored drive assures that the data on both drives of the mirrored pair are exactly the same. To verify RAID 5 redundancy, a parity check reads all associated data blocks, computes parity, reads parity, and verifies that the computed parity matches the read parity.

Cache Management

The DAC960 PCI RAID controller provides performance enhancement of data transfers through its on-board cache memory. The controller supports cache memory sizes from 2 MB (minimum) to 32 MB (maximum). Cache memory is allocated by the controller memory management functions for Read Cache and Write Cache. Write cache policy is user-selectable for each logical unit to achieve optimum performance within specific applications.

Read Cache

Read cache is always enabled by the controller. Its operation is transparent and requires no user intervention.

Write-Back Cache

Write-Back Cache refers to a caching strategy whereby write operations result in a completion status being sent to the host operating system as soon as the cache (not the disk drive) receives the data to be written. The target SCSI Drive will receive the data at a more appropriate time in order to increase controller performance.

Write-Through Cache

Write-Through Cache refers to a cache writing strategy whereby data is written to the SCSI Drive before a completion status is returned to the host operating system. This caching strategy is considered more secure, since a power failure will be less likely to cause loss of data. However, a Write-Through cache results in a slightly lower performance in most applications.

Cache Battery Backup

An available, optional cache battery backup can be used to protect against cache data loss in the event of a power failure.

Chapter 3

Installation

Overview

This chapter describes the installation of the DAC960 PCI RAID controller hardware, and the proper connection and configuration of its attached SCSI devices.

Requirements

The following items are required to perform this installation:

- DAC960 PCI RAID controller with memory installed
- Host system with an available PCI slot
- Configuration & Utilities diskette containing the DACCF utility
- SCSI cable(s) to interconnect the controller and the drives/devices
- Fast SCSI-2 or Wide SCSI compliant hard disk drives
- SCSI termination device(s) as required

Refer to the Configuration & Utilities diskette file *DISKLIST.TXT* for a list of disk drives and other devices that are compatible with the DAC960.

Optional Requirements

The following optional items also may be required, depending on your application or the type of installation:

- SCSI cable to interconnect the controller and external devices
- Battery back-up option for controller cache memory.

Before You Begin . . .

Installing the DAC960 PCI RAID controller is no more difficult than installing any PCI adapter card. Just follow these common-sense rules and the installation procedures should go flawlessly:

WARNING

Working with the covers off and power applied to the system can result in electrical shock and serious injury.

1. REMOVE POWER from the system before starting
2. Read all of the instructions in this manual through completely before proceeding, and observe the Notes, Cautions, and Warnings
3. Determine the system's SCSI ID and termination requirements and set the controller's jumpers as needed before installing it
4. Make sure that all of the cabling Pin 1 locations are correct
5. Make sure all SCSI conventions (cable type, cable length, termination, etc.) are correct
6. Safety check the installation before powering-on the system.

You may copy the DAC960 Installation Notes and Installation Checklist in this manual to use as a quick reference guide during the installation and configuration procedures.

INSTALLATION NOTES:

DAC960 PCI RAID Controller Setup:

SCSI ID	Drive Channel	Termination Jumper	Termination Enabled
* 7	Channel 0	J9/JP1	* Yes / _____
	Channel 1	J12/JP2	* Yes / _____
	Channel 2	J10/JP3	* Yes / _____

* Indicates Default Setting

SCSI Devices Installed:

Drive Channel 0

SCSI ID	Device Description	Termination Enabled (Y/N)	Drive Group
0	_____	_____	_____
1	_____	_____	_____
2	_____	_____	_____
3	_____	_____	_____
4	_____	_____	_____
5	_____	_____	_____
6	_____	_____	_____

Drive Channel 1 (Optional)

0	_____	_____	_____
1	_____	_____	_____
2	_____	_____	_____
3	_____	_____	_____
4	_____	_____	_____
5	_____	_____	_____
6	_____	_____	_____

Drive Channel 2 (Optional)

0	_____	_____	_____
1	_____	_____	_____
2	_____	_____	_____
3	_____	_____	_____
4	_____	_____	_____
5	_____	_____	_____
6	_____	_____	_____

DAC960 PCI RAID Controller Installation Checklist

- ___ 1. POWER-OFF all enclosure and system components
- ___ 2. Prepare the host system according to its documentation
- ___ 3. Determine the SCSI ID and termination requirements
- ___ 4. Check the DAC960 jumper settings
- ___ 5. Mount the controller into the system, connect the cables and terminators
- ___ 6. Identify the capacities of each of the connected drives (< 2 GB size?)
- ___ 7. **Safety check** the installation, then power-on the system
- ___ 8. If necessary, run the BIOS Options (Alt-M) at the prompt to match BIOS disk size setting to boot disk size geometry
- ___ 9. Load the DACCF configuration utilities software
- ___ 10. Format the drives (use the DACCF Tools *Format Drive* utility)
- ___ 11. Configure the Drive Groups (packs) and the logical units (System Drives)
- ___ 12. Initialize the logical units
- ___ 13. Install any required network operating system drivers (from Software Kit)
- ___ 14. (Optional) Install the Global Array Manager array monitoring software

Connectors and Jumpers

Connector and jumper locations on the DAC960P/PD/PD-Ultra controller are shown in Figure 3-1 and described in Table 3-1.

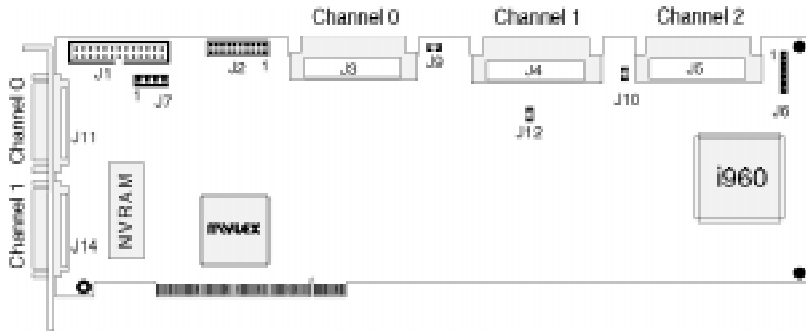

Figure 3-1. DAC960P/PD/PD-Ultra Series Component Locator

Table 3-1. DAC960P/PD/PD-Ultra Series Connectors and Jumpers

Connector	Description
J1	AEMI (Array Enclosure Management Interface) Port
J2	Connector, Battery Backup Module*
J3	Fast/Wide SCSI Connector, 68-pin, Drive Channel 0
J4	Fast/Wide SCSI Connector, 68-pin, Drive Channel 1*
J5	Fast/Wide SCSI Connector, 68-pin, Drive Channel 2*
J6	Connector block, Bus/Drive Activity LEDs
J7	Reserved (Factory test use only)
J9	Jumper, SCSI Termination, Drive Channel 0
J10	Jumper, SCSI Termination, Drive Channel 2*
J11	External Fast/Wide SCSI Connector, 8mm Champ, Drive Channel 0
J12	Jumper, SCSI Termination, Drive Channel 1*
J14	External Fast/Wide SCSI Connector, 8mm Champ, Drive Channel 1*
EEPROM	Only U47 is occupied for firmware versions prior to 3.x. U34 & U47 are both occupied for firmware 3.x or greater.

* Optional

Connector and jumper locations on the DAC960PL are shown in Figure 3-2 and described in Table 3-2.

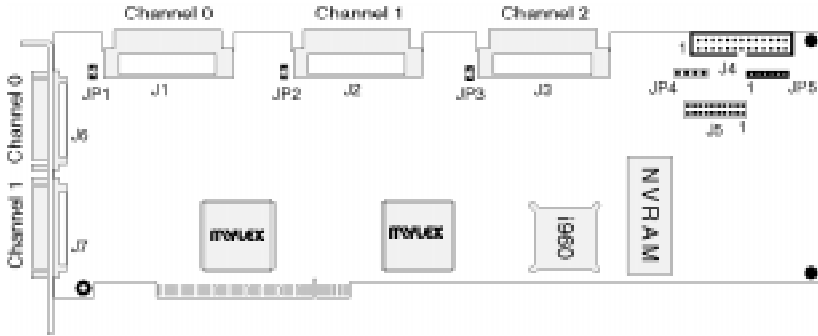

Figure 3-2. DAC960PL Component Locator

Table 3-2. DAC960PL Connectors and Jumpers

Connector	Description
J1	Fast/Wide SCSI Connector, 68-pin, Drive Channel 0
J2	Fast/Wide SCSI Connector, 68-pin, Drive Channel 1*
J3	Fast/Wide SCSI Connector, 68-pin, Drive Channel 2*
J4	AEMI (Array Enclosure Management Interface) Port
J5	Connector, Battery Backup Module*
J6	External Fast/Wide SCSI Connector, 8mm Champ, Drive Channel 0
J7	External Fast/Wide SCSI Connector, 8mm Champ, Drive Channel 1*
JP1	Jumper, SCSI Termination, Drive Channel 0
JP2	Jumper, SCSI Termination, Drive Channel 1*
JP3	Jumper, SCSI Termination, Drive Channel 2*
JP4	Reserved (Factory test use only)
JP5	Connector block, Bus/Drive Activity LEDs
EEPROM	Only U8 is occupied for firmware versions prior to 3.x. U8 & U29 are both occupied for firmware 3.x or greater.

* Optional

External LED Connectors

The DAC960 has a six-pin header that provides connection for three status LEDs. The pins are listed in Table 3-3. In each case, the odd-numbered pin is the +5V source (Pins 1, 3 and 5). Pin 1 is at the top of J6 on the DAC960P/PD/PD-Ultra, and at the left of JP5 on the DAC960PL. An external series resistor is not required for connecting LEDs.



Figure 3-3. Status LED Connectors

Table 3-3. Status LED Indicators

Connector	Indicator	Meaning if ON
JP5/J6, Pin 1-2	SCSI Activity	One (or more) of the SCSI channels on the controller is transmitting or receiving data
JP5/J6, Pin 3-4	PCI Activity	The controller is transmitting or receiving data to or from the host
JP5/J6, Pin 5-6	Write Pending	The cache memory on the DAC960 holds data that is more current than the data on the hard drive(s).

WARNING

DATA WILL BE LOST if the system either loses power or is reset while the Write Pending LED is ON (indicating the cache contains data not yet written to disk). To prevent data loss, install the optional cache battery backup module.

AEMI Interface Connector

Connector J1 is the AEMI (Array Enclosure Management Interface) connector and provides a set of inputs and outputs that can be used to interface the DAC960 PCI RAID controller with certain AEMI compliant Disk Array subsystem cabinets (refer to Appendix B).

SCSI Termination

Terminating a SCSI chain is accomplished either by adding a terminator, or by terminating the devices, on each of the two ends of the SCSI bus.

The DAC960 PCI RAID controller has on board ALT-2 type SCSI terminators on all drive channels. Jumpers J9, J12, and J10 are used to enable or disable the SCSI termination for Channels 0, 1, and 2 respectively.

By default, all three jumpers are installed when shipped from the factory (termination enabled). This is the normal termination required when the controller is installed at one end of the SCSI cable. In this case, whenever J9, J10, or J12 are shunted, the controller will provide termination to each SCSI channel, and will also power the SCSI TERMPWR signal for that SCSI bus.

Terminating Internal Disk Arrays

On a disk array system, the termination should be set in such a way that when any drive is removed from the SCSI bus, termination and termination power are left intact.

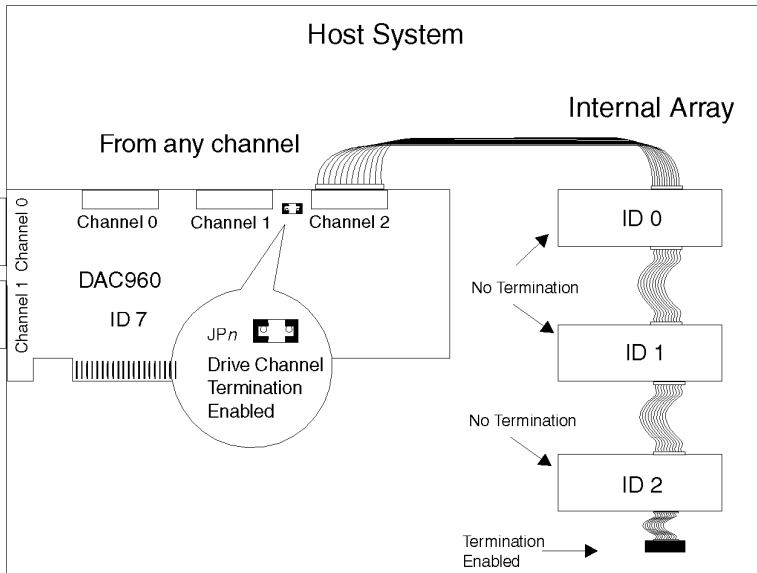

Figure 3-4. Internal Disk Array, Single-ended SCSI Termination

Terminating External Disk Arrays

There are up to five SCSI connectors on the DAC960 PCI RAID controller. The shielded .8mm champ 68-pin ultra high-density SCSI connectors on the external bracket are for external connection to Channel 0 and Channel 1. Channel 0 and Channel 1 signals are also available from the unshielded 68 pin D type SCSI connectors at the top of the controller.

For most array enclosures, the other end of the cable should have an independent terminator that is connected to the SCSI bus and is not part of any of the drives. This way the termination is not disturbed when any of the drives are removed or replaced.

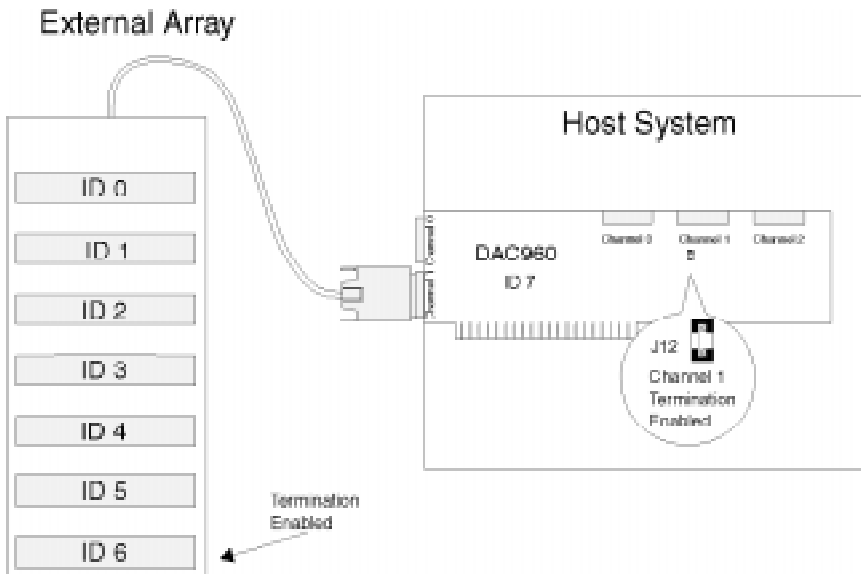

Figure 3-5. External Disk Array, Single-ended SCSI Termination

Terminating Combined Internal and External Disk Arrays

Both of the internal and external connectors can be used simultaneously. However, the termination jumper on the DAC960 must be removed for that channel because the controller is in the middle of the chain, and the SCSI bus must be terminated at both ends.

For most array enclosures, the end of the cable should have an independent terminator that is connected to the SCSI cable and is not part of any of the drives. This way the termination is not disturbed when any of the drives are removed or replaced.

Whenever a channel on the DAC960 PCI RAID controller is not at the end of a SCSI cable, remove the appropriate termination jumper for that channel and terminate the SCSI cable properly at both ends.

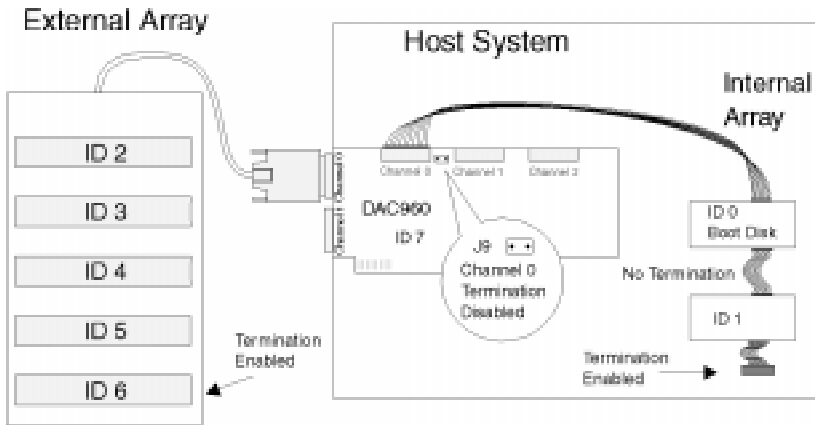

Figure 3-6. Combination External/Internal Disk Array, SCSI Termination

Selecting the Correct Terminator

Use ALT-2 type external SCSI terminators for operating a SCSI channel at 10M Bytes/second (or faster) synchronous transfer rates. Use ALT-1 type external SCSI terminators for operating a SCSI channel at 5M Bytes/sec synchronous or asynchronous transfer rate. The DACCF Configuration Utility can be used to set the transfer rate and mode for each channel.

Configuring the SCSI Devices

SCSI disk drives and other devices that will be connected to the controller will need a certain amount of preparation before they are installed. This may include setting jumpers to control termination power on the bus, drive spin-up order, and parity protocols

Setting Device Termination Power

All of the SCSI drives connected to the DAC960P Series should be shunted to apply power on the SCSI TERMPWR line, as well as having any of their built-in terminators disabled or removed. It is important that all drives supply termination power, so that power is applied to the SCSI bus even if drives are removed or replaced.

The same rules also apply to 'non disk' SCSI devices connected to any of the DAC960P Series SCSI channels.

Setting Drive Spin-up & Parity Jumpers

If all of the SCSI drives are connected to a single power supply, or if the power supply cannot supply the power needed to spin-up all of the drive motors simultaneously, then the controller should be configured to spin-up the drives separately. By spinning up the hard drives separately, the power supply is not unnecessarily loaded by the large starting current required to spin-up drives simultaneously. If drives are to be spun-up individually by the controller, they may need to be shunted to spin-up on command, not at power-on. See the specifications accompanying the SCSI drive for proper jumper settings.

Also, the DAC960 PCI RAID controller should be configured to spin-up the drives at regular intervals by giving each drive a spin-up command. See the DACCF Configuration Utility manual for more information on the disk drive spin-up options. Tape and CD-ROM spinup options should be left at the factory defaults.

The drive parity jumpers, if any, should be set to always *enable* parity on the SCSI data coming in, and to *send* parity with the data sent to the controller.

SCSI Cabling

Three things must be kept in mind while cabling the controller to the drives:

- SCSI Bus Termination
- System Performance
- SCSI Cable Length.

Every SCSI channel needs to be properly terminated with an appropriate SCSI terminator, as previously mentioned. In general, no drives should be terminated, and all drives must be shunted to supply TERMPWR on the SCSI bus.

Note: When connecting a Narrow SCSI (8-bit) cable to any DAC960 channel, the controller must be at one end of the bus and *Termination Enabled* must be set for that channel.

To get the best performance from the controller, the SCSI drives should be equally distributed across the SCSI channels, and the controller's data transfer rate should be set to the optimum rate for the drives being used.

Note: The SCSI transfer rate can be individually selected for each of the three channels on the DAC960P Series. For more information, refer to the DACCF Configuration Utility manual.

Figure 3-7 shows disk drives connected to two channels. The drive not included in a group can be a standby drive available to either group. The tape drive is connected to a separate channel from the disk drives.

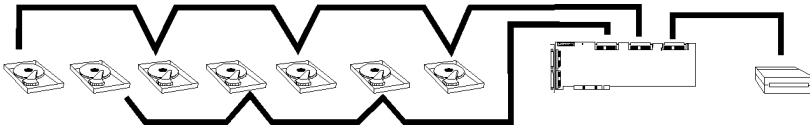

Figure 3-7. Drive Grouping Example

Cable Lengths

Generally speaking, as SCSI data transfer rates increase, maximum allowable cable lengths decrease. Transfer rates of 5 MB/sec for 8-bit SCSI or 10 MB/sec for 16-bit SCSI will normally allow a 6 meter (20 foot) maximum cable length on a channel. Transfer rates of 40 MB/sec for 16-bit Ultra SCSI permit a maximum cable length of only 1.5 meters, if more than 4 devices are on the channel.

Note: Strict adherence to guidelines for over-all cable length is necessary when connecting Ultra-SCSI drives that will operate at the higher data transfer rates of the Fast-20 standard (refer to ANSI STD X3.131 for information on SCSI cabling requirements).

Table 3-4. Supported SCSI Formats and Cable Lengths

SCSI Type	Clock Rate	Data Rate	Connector	Cable Length
Ultra-SCSI* (16-bit)	20 Mhz	40MB/sec	68-pin	3m (10 ft)‡
Ultra-SCSI* (8-bit)	20 Mhz	20MB/sec	68-pin or 50-pin†	3m (10 ft)‡
Wide SCSI-2 (16-bit)	10 Mhz 5 Mhz	20 MB/sec 10 MB/sec	68-pin	3 m (10 ft) 6 m (20 ft)
Narrow SCSI-2 (8-bit)	10 Mhz 5 Mhz	10 MB/sec 5 MB/sec	68-pin or 50-pin†	3 m (10 ft) 6 m (20 ft)
SCSI-1 (8-bit)	5 Mhz	5 MB/sec	50-pin†	6 m (20 ft)

*DAC960PD-Ultra only

† 50-pin to 68-pin adapter required

‡ 3 meters with up to 4 SCSI devices or 1.5 meters with more than 4 SCSI devices

Connecting Non-Disk Devices

Non-disk SCSI devices, such as a tape drives or CD-ROM drives, will need to have their own unique SCSI ID, regardless of the channel of the DAC960 controller to which they are connected. For instance, the general rule for UNIX systems is to set the tape to SCSI ID 2, the CD-ROM to SCSI ID 5, with both devices connected to channel 0.

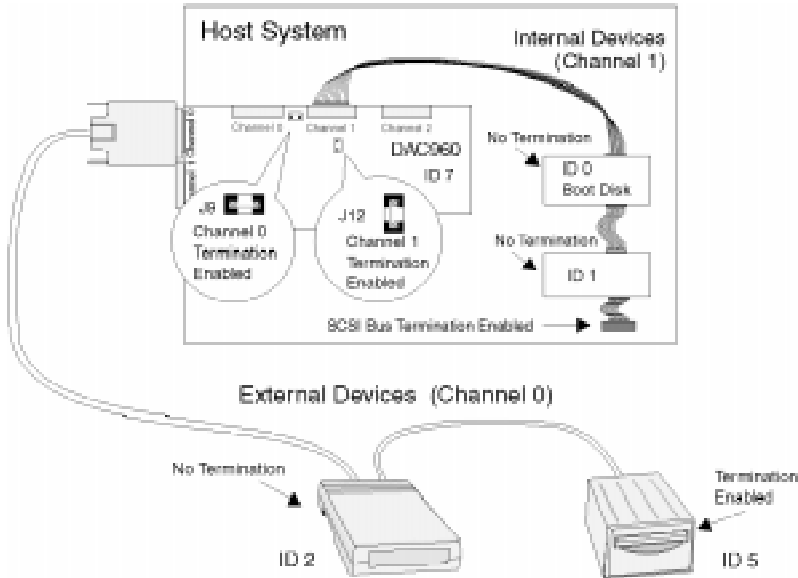

Figure 3-8. Connecting Non-disk Devices

Caution

Connecting non-disk devices to DAC960 drive channels can result in disk drive performance loss.

While the DAC960 PCI RAID controller does support non-disk devices, their use on SCSI channels containing disk drives is not recommended. The affect these devices have is to slow the controller's performance on that channel to the I/O transfer rate of the tape or CD-ROM drive, instead of the much faster rates supported by most hard drives.

You can work around this problem by connecting the non-disk devices to one channel of the DAC960, while connecting the hard drives to the other channels. However, most people do not wish to give up one channel of a high-performance, caching disk array controller for this purpose. The simple solution is to use a dedicated Bus Logic SCSI host bus adapter for connecting all non-disk devices.

For more information on configuring the DAC960 PCI RAID controller, be sure to read the *DACCF Utilities Installation Guide and User Manual*, Chapter 2, *Configuration Strategies*.

Using a UPS

Installation of an uninterruptable power supply (UPS) is highly recommended on systems that use a DAC960 PCI RAID controller not equipped with the battery backup option. Loss of power to the controller during system activity can result in loss of data; because data in the controller cache that is waiting to be written to disk will be lost unless the controller has the optional cache battery backup installed.

Installation of a UPS may eliminate this situation completely. If properly installed, the UPS will supply uninterrupted power to the host system and its drives and allow the operating system to properly shut down before power is removed from the system.

Cache Battery Backup Option

The optional cache battery backup provides temporary protection for unwritten data in the controller's cache memory in the event of a system reset or power loss. Data maintained in the cache will be written to disk after power is restored.

The optional cache battery backup module is available for the DAC960 PCI RAID controller to provide, in the event of a power failure, battery backup to the SIMM module installed on the controller.

Battery Backup Module Connector

Connector J2 is available for the optional cache battery backup module. If the optional cache battery backup module is not installed, the loop-back plug must be present on connector J2 for proper controller operation.

WARNING

Be careful to observe proper orientation when inserting a battery backup module or the loop-back plug in connector J2. Check to make sure that Pin 1 on the module corresponds to Pin 1 on connector J2, and that all pins are mating properly before full insertion. Improper insertion may result in physical damage to the controller.

Chapter 4

Startup Sequences

Introduction

This chapter describes the DAC960 PCI RAID controller startup procedures and messages produced by the BIOS during startup or re-boot. This chapter also explains three BIOS options to be considered: BIOS enable/disable, CD-ROM boot enable/disable, and a 2 or 8 GigaByte Disk Drive Geometry setting.

The DAC960 BIOS provides a single threaded interface to access up to eight logical units (system drives) on each controller.

The BIOS presents "system drives" to the host as large disk drives with 32 sectors per track and 128 heads per cylinder (giving 2MB per cylinder). With Firmware 3.x, the cylinder limit has increased from 1024 to 4096, allowing a system drive of up to 8GB to be accessed through the BIOS. An operating system specific driver is required to access data beyond this limit.

Refer to the documentation for the DAC960 Software Kit for more information on installing and using the various network operating system drivers with the DAC960PD.

Instructions on using the DOS driver and creating a DOS-bootable disk are located in the DACCF Configuration & Utilities diskette DOS subdirectory in the file *README.TXT*.

System Power-Up Sequence

If the SCSI drives are powered up separately from the system, you should always power up the SCSI drives before the host system. The drives and the host system can power up simultaneously, as they would when there is a common power switch for both.

BIOS Startup Sequence

When invoked during power up, the BIOS will display a sign-on message with its version number and date. The sign-on message looks similar to the following:

```
DAC960Px BIOS Version n.nn--
```

This will be followed by:

```
Spinning up drives....  
DAC960 Firmware Version 3.nn-n-n  
DAC960 Memory = xMbytes (DRAM)  
Press Alt-M for BIOS options
```

At this point, the user has the option of holding down the **Alt** key and pressing the **M** key to go into the BIOS options menu (see the following subsection *Setting BIOS Options*). If the user does nothing, the sequence continues.

Next, the BIOS tries to locate the DAC960 PCI RAID controller. Once the DAC960 controller is located, it determines if the controller firmware is operational.

Setting BIOS Options

There are three DAC960 BIOS options that need to be considered and possibly changed during installation of the DAC960 PCI RAID controller. This is usually a one-time requirement. The BIOS options are:

- BIOS enabled/disabled
- CD-ROM boot disabled/enabled
- 8/2 GB drives enabled

Invoking the BIOS Options Menu

When starting the system with a DAC960 PCI RAID controller installed, the startup sequence displays a series of messages that confirm or deny successful SCSI device installation. These messages are followed by the following prompt:

```
Press Alt-M for BIOS options
```

There will be a pause for approximately two seconds in which this option can be invoked. To examine or change the BIOS options, press and hold the **Alt** key and then press **M**.

The following menu will appear:

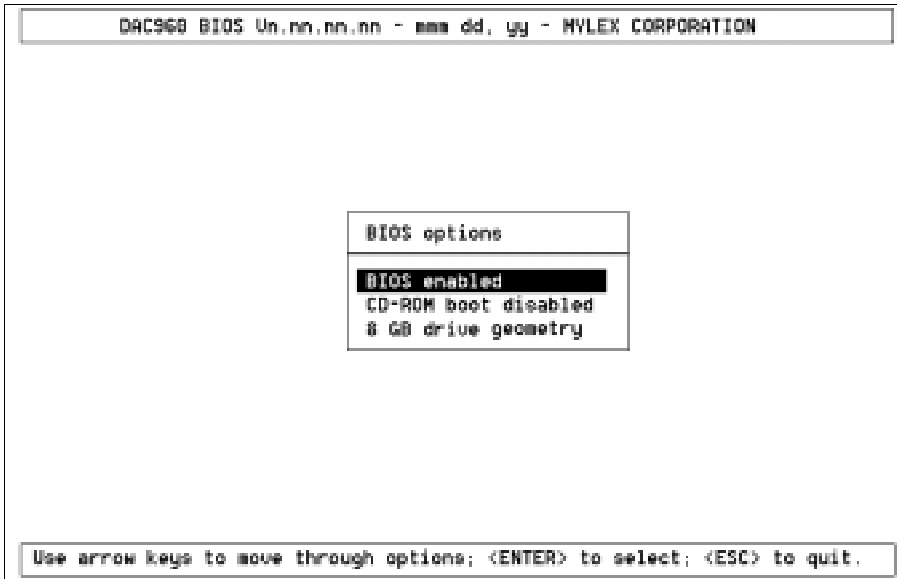

Figure 4-1. BIOS options Menu

Use the up and down arrow keys to highlight the BIOS options to be toggled. While a desired option is highlighted, press the **Enter** key to toggle the option.

Note: If the BIOS is disabled, it will not be possible to change the other options.

If the boot drive is on a DAC960, then drive geometry changes should not be attempted unless the boot drive is going to be reformatted. The option to change the disk drive geometry between 8 gigabytes and 2 gigabytes stops and generates a warning about the potential of data loss before the change proceeds.

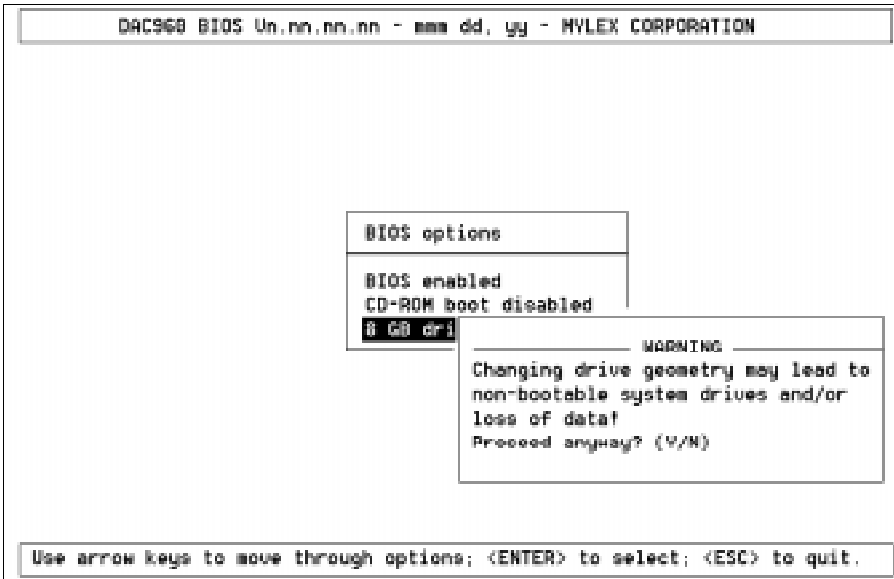

Figure 4-2. BIOS Options Menu when Drive Geometry Option is Selected

Press the **Esc** key to exit the BIOS options menu. The following message will be displayed:

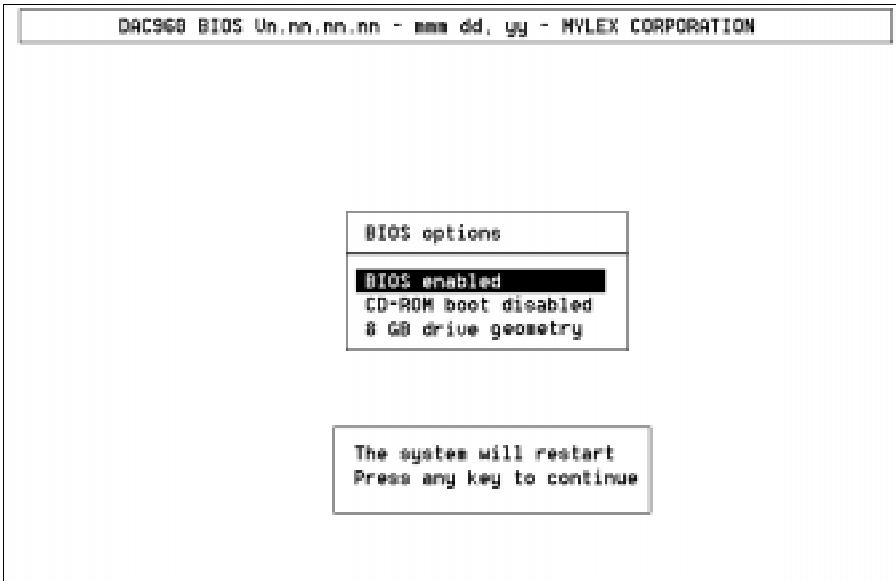

Figure 4-3. BIOS Options Menu Prior to Exit

BIOS Enable or Disable

The default for this option is for the BIOS to be enabled. Disabling the BIOS prevents the DAC960 from being the boot controller. While the BIOS is disabled, it will not be possible to make changes to the other BIOS options.

CD-ROM Boot Disable or Enable

The default for this option is for the CD-ROM boot to be disabled (e.g., the system will boot from a hard drive. If a bootable CD is installed in the CD-ROM drive, the system can boot from the CD if this option is set to enabled.

If the CD-ROM boot option is enabled, the CD-ROM will take priority over the disk drives. For example, under MS-DOS, the disk drive that is normally Drive C: will become Drive D. All subsequent drive IDs will similarly be moved down.

Enable 8 GByte or 2 GByte Drives

This option can be toggled between 8 GByte and 2GByte drive geometries. The default is 8 GB. This setting affects how the system reads the disk drives. The drive geometry must be set and then the drive must be formatted (or reformatted). If any drives with a capacity of more than 2 GB are installed, or if there is a plan to install such drives later, the 8 GB option should be selected. This is necessary to enable more than the first 2 GB of the larger drives to be read.

All disk drives on the DAC960 PCI RAID controllers in the system must have the same geometry setting.

The system will not be able to read a drive that has been formatted with the 2 GB geometry when a new DAC960 with Firmware 3.x is first installed, because the DAC960's BIOS is shipped with the geometry set to 8 GB. If this is the case with the boot drive, the boot sequence will terminate with a message similar to:

```
Missing operating system
```

The same error will occur with a drive formatted with 8 GB geometry if the current BIOS geometry setting is configured for 2 GB. If this error occurs, restart the system , go back into the BIOS Options menu, and change this setting.

Error Messages

Startup Error Messages

The BIOS also looks for any initialization message that may be posted by the firmware during the startup sequence. If it finds a message, it displays one of the following errors on the screen and aborts the installation process.

```
DAC960 fatal error--memory test failed
```

```
DAC960 fatal error--command interface test failed
```

```
DAC960 hardware error--run diagnostics to pinpoint error
```

```
DAC960 firmware checksum error--reload firmware
```

Drive Check Error Messages

If the firmware finds a valid DAC960 configuration, but it doesn't match the SCSI drives currently installed, one or more of the following messages will be displayed:

```
Unidentified device found at channel x...  
Device identified for chn x, tgt y found at chn x', tgt y'  
SCSI device at chn x, tgt y not responding
```

If any of the above messages are displayed, the firmware will not proceed any further in the initialization process, except to find other mismatches. Then, the BIOS will print out the following:

```
DAC960 Configuration Checksum error--run configuration  
utility  
Mismatch between NVRAM and Flash EEPROM configuration
```

At the next stage the following message may appear:

```
Recovery from mirror race in progress
```

This will be displayed if the firmware detects that during the last power cycle, the system was turned off abruptly, leaving some incomplete write operations.

The following messages may also appear:

```
Adapter cannot recover from mirror race!  
Some system drives are inconsistent!
```

During the initialization, if the firmware fails to respond to the BIOS inquiry within two minutes, the following message will be displayed:

```
DAC960 not responding--no drives installed.
```

The BIOS then inquires the firmware for its version number and other information, and prints out the following message:

```
DAC960 firmware version x.xx
```

One or more of the following messages will be displayed if the firmware reports the following conditions:

```
Warning: X system drives are offline  
Warning: X system drives are critical
```

```
Warning: The following SCSI devices are dead--chn x, tgt y...
No system drives found: None installed
X system drives installed
```

The BIOS repeats the same process for additional DAC960 controllers present in the system. Then it proceeds to boot, if possible, from the first system drive on the first DAC960 controller.

Aborted Installation

With Firmware 3.x, the installation aborted message is displayed when the BIOS finds that the configuration of the disk drives, as stored in the NVRAM and configuration on disk, is different from what it sees at boot time. When this happens, (and a brand new installation is not being attempted) the cause is often a faulty cable or drive, or a loose connection. Check all of the connectors, cables, drives, and try to boot. If the error persists, it most likely indicates a genuine failure and needs to be corrected. To correct it, boot DOS and run the configuration utility. For more information, refer to the *DACCF Utilities Installation Guide and User Manual*.

NVRAM Error

With Firmware 3.x, if the BIOS displays a mismatch between the NVRAM and the COD, no drives will be installed. Normally this error will not be displayed. If it is, boot DOS and run the configuration utility to recover from the error. For more information, refer to the *DACCF Utilities Installation Guide and User Manual*.

System Reboot or Power Down

Status messages may also be available from LED indicators connected to the DAC960 PCI RAID controller. The 'Write Pending' indicator is especially important when preparing to power-down the system.

The DAC960 is a caching controller with up to 32MB of cache memory, data may still be in the cache, waiting to be written to the disk drives, when the system reports that a write command was completed. It is **very important** to make sure that all data is written to the disk before rebooting or powering

down the system, or you may lose data. It is always a good idea to wait for 15 seconds before any resetting/rebooting of the system.

If using the 'Write Pending' LED indicator, wait for 3 seconds after the LED has gone off before resetting or rebooting the system (the optional cache battery backup may also be used to prevent data loss).

Appendix A

Enclosure Management

Introduction

The DAC960 PCI RAID controllers support enclosure management protocols. This feature allows the host to monitor drive enclosures and detect certain faults or operating environment conditions. The host can make a decision to shut down the system or issue a warning based on the type of fault detected.

The DAC960 PCI RAID controller supports the industry standard enclosure management protocol *SCSI Accessed Fault-Tolerant Enclosures* (SAF-TE) and the *Mylex Array Enclosure Management Interface* (AEMI) protocol.

SAF-TE

The SAF-TE protocol follows a specification jointly worked out by nStor Corporation and Intel Corporation. Enclosures that are compliant with this protocol are known as SCSI Accessed Fault-Tolerant Enclosures (SAF-TE). The protocol is compatible with standard SCSI buses and cabling.

The SAF-TE interface standard's objective is to provide a non-proprietary means of allowing third-party disks and controllers to be automatically integrated with peripheral enclosures that support:

- Status Signals (LEDs, audible alarms, LCDs, etc.)
- Hot swapping of drives
- Monitoring of fans, power supplies, and enclosure temperature

SCSI is the underlying transport mechanism for communicating enclosure information. All standard SCSI host adapters will work. There is no need to consider reserved signals or special cabling.

The SAF-TE interface can be implemented as a SCSI target that uses a SCSI port and an 8-bit microcontroller.

All communication is initiated by the host. The SAF-TE processor acts only in target mode. The SAF-TE processor should be periodically polled by the host approximately every 2 to 10 seconds.

AEMI

The AEMI protocol uses a separate 26-pin connector and cable combination to monitor disk drive enclosure status and detect faults. A cable is used to connect from the AEMI connector on the DAC960 controller to a similar connector on an AEMI compliant enclosure. The AEMI connector supports:

- Status Signals (LEDs, audible alarms, LCDs, etc.)
- Hot swapping of drives
- Monitoring of fans, power supplies, and enclosure temperature

On DAC960P, DAC960PD, and DAC960PD-Ultra controllers, the AEMI connector is J1. On DAC 960PL boards, the AEMI connector is J4. For the location of Pin 1 on the AEMI connector, see Figure A-1.

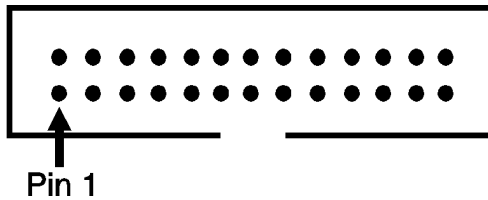

Figure A-1. AEMI connector Pin 1 Location

Table A-1. AEMI Fault Signals Connector, Distribution Board

Pin	DAC Signal	Input/ Output	Active	Definition	Description
1	(reserved)	N/C	-	-	DO NOT connect this pin!
2	PBO10	Out	High	ALARM	Alarm signal
3	(reserved)	N/C	-	-	DO NOT connect this pin!
4	SHI2	In	Low	TMPFLT	Over temperature
5	PBO2	Out	High	ERRLED0	Fault indicator for ID 0
6	PBO11	Out	Low	STBCHN0	Strobe for Channel 0
7	PBO3	Out	High	ERRLED1	Fault indicator for ID 1
8	SWI1	In-Latch	Low	ALRST	Alarm reset
9	PBO4	Out	High	ERRLED2	Fault indicator for ID 2
10	VCC	-	-	VCC	+5 Volts
11	PBO5	Out	High	ERRLED3	Fault indicator for ID 3
12	PBO12	Out	Low	STBCHN1	Strobe for Channel 1
13	PBO6	Out	High	ERRLED4	Fault indicator for ID 4
14	VCC	-	-	VCC	+5 Volts
15	PBO7	Out	High	ERRLED5	Fault indicator for ID 5
16	PBO13	Out	Low	STBCHN2	Strobe for Channel 2
17	PBO8	Out	High	ERRLED6	Fault indicator for ID 6
18	GND	-	-	GND	Ground
19	SHI0	In	Low	PSUFLT	Power supply failure
20	PBO14	Out	High	OFMACTIVE	Fault Management Enabled/Active
21	SWI0	In-Latch	Low	ANYSWAP	Force SCSI scan
22	GND	-	-	GND	Ground
23	SHI1	In	Low	FANFLT	Fan Failure
24	PBO15	Out	N/A	ARMCERTO	ARM Certified subsystem Output
25	PBO9	Out	-	(reserved)	-
26	SWI2	In-Latch	N/A	ARMCERTI	ARM Certified subsystem Input

A

Aborted Installation 4-8
AEMI A-2
 Connector 3-7

B

Bad Data, Management of 2-4
BIOS Options 4-2
 Enable or Disable 4-5
 Menu 4-2
BIOS Startup Sequence 4-2

C

Cable Lengths 3-13
Cache Management 2-22
 Battery Backup 2-22
 Read 2-22
 Write-Back 2-22
 Write-Through 2-22
CD-ROM Boot Disable/Enable 4-5
Configuration on Disk (COD) 1-4, 2-4,
 2-9
Configuring SCSI Devices 3-11
Connecting Non-Disk Devices 3-14
Connectors 3-7
Controller Components 2-2
Controller Functions, Features 1-4

D

Disk Drive Geometry 4-6
Drive Groups 2-8
Drive Management 2-17
Drive Organization 2-8
Drive States 2-17

E

Enclosure Management A-1
Error Messages 4-6

External LED Connectors 3-7

F

Failure Detection, Disk 2-21
Firmware 3.x 1-4, 2-2
 New Features 1-4
 Overview 2-2

H

Hot Spares 2-20
Hot-Swap Drive Replacement 2-21

I

Installation 3-1
 Before You Begin 3-2
 Checklist 3-4
Introduction 4-1, A-1

J

JBOD 2-12
Jumpers 3-5
 Drive Parity 3-11

L

Logical Unit States 2-19
 Critical 2-19
 Off-line 2-19
 On-line 2-19
Logical Units 2-8

M

Mirroring 2-13

N

Non-Disk Devices 3-14
NVRAM Error 4-8

O

Overview 2-1, 3-1

P

- Parity 2-22
 - Drive Parity Jumpers 3-11
- Physical Drive Groups or Packs 2-8
- Physical Drive States 2-17
 - Dead 2-17
 - On-line 2-17
 - Ready 2-18
 - Standby 2-17
 - Write-Only 2-18
- Power-Up Sequence 4-2

R

- RAID 0 2-13
- RAID 1 2-13
- RAID 5 2-15
- RAID Management 2-11

S

- SAF-TE A-1
- SCSI Termination 3-8
- Spin-up Options 3-11
- Standby Drives 2-20
- Striping 2-13
- Striping with Parity 2-15
- System Drives 2-8

T

- Termination 3-8
- Termination Power 3-11

U

- UPS 3-15



MYLEX™

Mylex Corporation
34551 Ardenwood Blvd.
Fremont, CA 94555-3607
U.S.A.

TEL: (510) 796-6100

FAX:
Domestic Sales: (510) 745-8016
International Sales: (510) 745-7521

www.mylex.com

MADE IN U.S.A.

MYLEX DAC960 Problem Report

Customer Identification								DAC960 Identification			
Name: _____								Date: _____ Purchase Date: _____			
Company: _____								Model _____			
Address: _____								Invoice Number: _____			
_____								Serial Number: _____			
Country: _____								# Chnls: _____ Cache: _____			
Phone Number: _____								Firmware Ver: _____ BIOS Ver: _____			
Fax Number: _____								Make/Model/Size/Type of _____			
_____								Drives: _____			
_____								Disk: _____			
_____								Non-Disk: _____			
System Information											
Motherboard: _____				CPU Speed: _____				BIOS Ver: _____			
Video Adapter: _____				Network Card: _____				MB Memory: _____			
Operating Sys: _____				Other Disk Ctrl: _____				Other Cards: _____			
Pack Configuration								System Drive Configuration			
Indicate in matrix below 1, 2... for member of pack 1, pack 2... respectively. Indicate S, T, C, or O for Standby, Tape, CDROM and other drives.								System Drive	Size	RAID Level	Write Back/ Thru
								0			
Channel	SCSI ID							1			
	0	1	2	3	4	5	6	2			
0								3			
1								4			
2								5			
3								6			
4								7			
Problem Description											

This DPR form has been included with your Mylex product as a convenience to both you and our Technical Services Department. If filled out completely, this will greatly assist Mylex personnel in quickly resolving any technical problems or questions you may have. Use the Mylex fax number (510) 745-7715 to transmit this form to the Technical Services Department, or mail to Mylex Corporation, Technical Services Department, 34551 Ardenwood Blvd., Fremont, CA 94555-3607

Mylex Warranty - Customer Policy

Thank you for purchasing this Mylex product for your computer system. In addition to this high-quality product, your purchase entitles you to the warranty coverage set forth herein. In order to provide this warranty coverage, and to indicate your acceptance of this warranty, we must have the attached Warranty Registration Card completed and returned to us within 15 days of your purchase. Also, in order for us to provide you the highest level of service, we must know where you purchased your MYLEX product.

Three Year Limited Warranty

If at any time during the thirty six month period immediately following the date of original purchase of the MYLEX product enclosed herewith (the "PRODUCT") you discover one or more defects in the material or workmanship, MYLEX will repair, or at MYLEX's sole option, replace the PRODUCT. If the PRODUCT fails to operate at any time within seven days after the date of its original purchase, it will be replaced by MYLEX. Such repair or replacement will be your sole remedy against MYLEX, and MYLEX's only liability to you, for any failure or malfunction of the PRODUCT. The warranty set forth in this paragraph will be void if:

1. The PRODUCT has been installed in an improper manner or in an improper operating environment.
2. The PRODUCT has been modified or repaired by any party other than MYLEX or a MYLEX factory authorized service center.
3. The PRODUCT has been damaged.

Some MYLEX products will have a Warranty Expiration Date label affixed to the product itself. When present, the warranty period will extend through the last day of the month indicated.

This warranty will not apply to, and MYLEX provides no warranty for, any BIOS, software, ROM-based firmware, or any other PRODUCT developed or manufactured by any third party, whether included with this PRODUCT or not. Such warranty or warranties as are provided by third parties, to the extent permitted thereby, shall be made available, and are hereby assigned, by MYLEX to the purchaser of this PRODUCT.

If MYLEX issues a revision to the BIOS, firmware or software included with this PRODUCT within 30 days of your purchase, MYLEX will replace such firmware at no charge except handling fees.

Out of Warranty Service

Mylex products which are ineligible for warranty service may be serviced by MYLEX according to our standard price list, as modified from time to time. A current copy of the standard price list is available from the Technical Support Department.

Limitation of MYLEX Liability

MYLEX's liability arising from the sale, use and disposition of this PRODUCT shall in no event exceed the amount paid to MYLEX for this PRODUCT. MYLEX assumes no liability for damages arising from the use or failure of any MYLEX product. The WARRANTY DESCRIBED ABOVE CONSTITUTES THE ONLY WARRANTY MADE BY MYLEX. MYLEX EXPRESSLY DISCLAIMS ANY AND ALL OTHER WARRANTIES OF ANY KIND WHATSOEVER, WHETHER EXPRESSED OR IMPLIED, INCLUDING WARRANTIES OF MERCHANTABILITY AND FITNESS FOR A PARTICULAR PURPOSE, WHICH ARE HEREBY EXPRESSLY EXCLUDED. IN NO EVENT WILL MYLEX BE LIABLE FOR INCIDENTAL, SPECIAL OR CONSEQUENTIAL DAMAGES (INCLUDING WITHOUT LIMITATION LOSS OF DATA, USE, OR INCOME), EVEN IF ADVISED OF SUCH DAMAGES IN ADVANCE. Your sole remedies shall be as provided herein.

Returned Merchandise Procedures

If you suspect that there is a defect in the material or workmanship of this PRODUCT, you should contact the person or company from which you purchased it. That person or company may be able to solve the problem and if not, will be able to contact us for technical assistance or repair.

If it is determined that the PRODUCT must be returned to MYLEX for repair or replacement, a Return Merchandise Authorization (RMA) number must be obtained from MYLEX's Technical Department before it is returned. Each returned item must have a separate RMA number.

The following rules apply to all returned items:

1. The PRODUCT must be returned either in its original packaging or in other packaging which is appropriate for the PRODUCT and the manner of shipment, and the RMA number must be displayed prominently on the outside of each such package.
2. If a PRODUCT is determined to be ineligible for warranty service, the customer will be notified before any further action is taken with the PRODUCT.
3. MYLEX will not be responsible for any loss or damage to property shipped with the RMA PRODUCT not originally sold by MYLEX (e.g., coprocessor chips, peripheral boards, memory modules, enclosures, power supplies, or any other accessories or attached items).
4. Any item returned to MYLEX without a valid RMA number will be returned to the shipper.

Products shipped to MYLEX must be shipped or mailed at the shipper's risk, freight prepaid, to the address below.

Mylex Corporation
34551 Ardenwood Blvd.
Fremont, California U.S.A.
94555-3607

Mylex will pay for return freight via such carrier as MYLEX shall deem appropriate.

Technical Support

Technical support, to assist you in resolving problems with MYLEX products, is now available through MYLEX's Technical Support Department. In the U.S.A., the Technical Support Department can be reached by telephone at (510) 796-6100 or by FAX at (510) 745-7715. Current hours of operation, which are subject to change, are from 8:00 a.m. through 5:00 p.m. Pacific Time, Mondays through Fridays, excluding U.S.A. national holidays.

Included with the shipment of most MYLEX products is a System Problem Report (SPR) form. When contacting the Technical Support Department for assistance with an installation or compatibility problem, we recommend that this form be completed and sent by facsimile or mail to MYLEX. Completion of this form will allow our Technical Support Department to solve most technical problems expeditiously.

Mylex will make reasonable efforts to address compatibility problems which may arise with respect to third party products, but shall not be responsible for the compatibility of its products with the products of any third party. Customers are advised to verify each products compatibility with their installation before committing to any particular procurement plan.

WARRANTY REGISTRATION CARD

To validate your warranty and receive any future updates concerning your product, you must complete and return this Warranty Registration Card within 10 days of purchase. (Please Print)

NAME: _____ COMPANY: _____

ADDRESS: _____ CITY: _____

STATE: _____ ZIP CODE: _____ COUNTRY: _____

TELEPHONE: _____ FAX NO: _____

DATE PURCHASED: _____ MODEL NO: _____ SERIAL NO: _____

PURCHASED FROM: _____

ADDRESS: _____ CITY: _____

STATE: _____ ZIP CODE: _____ COUNTRY: _____

In order for Mylex to better serve your needs, please complete the following:

1. How did you first learn about MYLEX products?

- Advertisement (Name of Pub) _____ Article Review Friend
 Retailer _____ Salesperson Other

10. Have you ever purchased Mylex products in the past?

- Yes No

If yes, which products? _____

2. Where will this product be used?

- Home Workplace

11. Who purchased this product?

- Individual Company

3. What other brands, if any, did you consider? _____

4. Please indicate the most common uses of your system: _____

- Personal Business Graphics (CAD/CAM or Business Graphics) Accounting
 Data Retrieval Multi-User Multi-Tasking Database

5. Which factor most influenced your purchase?

- Company Reputation Price Features (List) _____ Performance

6. What does your computer system include? (Please specify brand and model)

- System Unit _____ Peripherals _____
 Color Monitor _____ Monochrome Monitor _____

7. What add-ons or peripherals are you most considering for future purchase? _____

8. What best describes your occupation?

- Management/Administration Sales/Service Technical-Scientific/Engineering Student Other _____

9. Do you have any comments or suggestions? _____