

**SWXTL-AA 6.0-GB
DLT Cartridge Tape Drive
Storage Building Block (SBB)**

User's Guide

Order Number: EK-SM1TD-UG. A01

First Edition, July 1994

The information in this document is subject to change without notice and should not be construed as a commitment by Digital Equipment Corporation. Digital Equipment Corporation assumes no responsibility for any errors that may appear in this document.

Restricted Rights: Use, duplication, or disclosure by the U.S. Government is subject to restrictions as set forth in subparagraph (c) (1) (ii) of the Rights in Technical Data and Computer Software clause at DFARS 252.227-7013.

Digital Equipment Corporation does not give a warranty of any kind regarding the fitness or applicability of the information content for a particular purpose. The user assumes all responsibility for understanding the interrelationships of this enclosed information with other affected software or system products.

The disclosure of this information does not grant to the user a license under any patents, pending patents, trademarks, or copyrights or other rights of Digital Equipment Corporation, or of any third party.

FCC Notice: This equipment has been tested and found to comply with the limits for a Class B digital device, pursuant to Part 15 of the FCC rules. These limits are designed to provide reasonable protection against harmful interference in a residential installation. Any changes or modifications made to this equipment may void the user's authority to operate this equipment. The shielded interconnect cable, as supplied with the unit, may not be substituted, nor altered or modified, in any way.

This equipment generates, uses, and can emit radio frequency energy and, if not installed and used in accordance with the instructions, may cause harmful interferences to radio communications. However, there is no guarantee that interference will not occur in a particular installation. If this equipment does cause harmful interference to radio or television reception, which can be determined by turning the equipment off and on, the user is encouraged to try to correct the interference by one or more of the following measures:

- Reorient or relocate the receiving antenna.
- Increase the separation between the equipment and receiver.
- Connect the equipment into an outlet on a circuit different from that to which the receiver is connected.
- Consult your reseller or an experienced radio/TV technician for help.

Copyright © Digital Equipment Corporation 1994

All Rights Reserved

Printed in U. S. A

The following are trademarks of Digital Equipment Corporation:

DEC

Digital

StorageWorks

VMS

and the Digital Logo:



All other trademarks and registered trademarks used in this publication are the property of their respective owners.

Contents

Revision Record	vii
------------------------------	-----

About This Guide	ix
-------------------------------	----

1 Introduction

1.1	Product Overview	1-1
1.2	Design Features.....	1-1
1.2.1	Basic Components	1-1
1.2.2	Performance Considerations.....	1-1
1.3	Data Tape	1-2
1.3.1	CompacTape III Description.....	1-2
1.3.2	Cartridge Packaging.....	1-3
1.4	Reading and Writing Data.....	1-3
1.4.1	Write-Protecting Data	1-3
1.5	Cleaning Tape.....	1-4
1.5.1	CleaningTape III Description.....	1-4
1.5.2	CleaningTape III Packaging.....	1-4
1.5.3	CleaningTape III Cartridge Expiration	1-4
1.6	Supplies	1-5
1.6.1	Cartridges Provided	1-5
1.6.2	How To Order Replacement Cartridges	1-5

2 Installation and Operation of the SWXTL-AA SBB Tape Drive in a Storage Subsystem

2.1	Introduction	2-1
2.2	Unpacking.....	2-1
2.3	Preinstallation Procedures	2-2
2.3.1	Setting the SCSI ID Address of the Tape Drive.....	2-2
2.3.2	Disabling Parity Checking in the Tape Drive	2-3
2.4	Installing the SWXTL-AA SBB Tape Drive Into a StorageWorks Expansion Storage Subsystem	2-3
2.5	Power On Self Test (POST)	2-4

3 Front-Panel Controls & Indicators and Operation

3.1	General	3-1
3.2	Front-Panel Controls and Indicators	3-1
3.2.1	Tape Status Indicators.....	3-1
3.2.2	Unload Push-Button.....	3-1
3.2.3	Cartridge Insert/Release Handle.....	3-2
3.3	Power-On Self-Test (POST).....	3-2

3.4	Status Indication of Tape Drive LEDs.....	3-4
3.5	CompacType III DLT Tape Cassette.....	3-4
3.5.1	Using and Handling CompacTape III Tape Cassettes.....	3-4
3.5.2	Write-Protect Switch	3-6
3.5.3	Data Protection.....	3-7
3.5.4	Loading A Cartridge.....	3-8
3.5.5	Tape in Use	3-8
3.5.6	Unloading A Cartridge.....	3-10
3.5.7	Using the Tape Cleaning Cartridge.....	3-11
3.5.8	Preserving Cartridges.....	3-12
3.6	Density Selection Rules	3-12

4 Maintenance

4.1	Introduction	4-1
4.2	Common Errors	4-1
4.2.1	Avoiding Basic Problems.....	4-1
4.2.2	Error Influences.....	4-1
4.3	Cleaning the Heads.....	4-2
4.4	Inspections.....	4-3
4.4.1	Checking the Cartridge Leader	4-3
4.4.2	Checking the Drive Leader	4-3
4.5	Troubleshooting.....	4-6

Appendix A	Specifications	A-1
Appendix B	Product Notes for Novell™ and MS-DOS™	B-1
B.1	Host SCSI Interface.....	B-1
Appendix C	Density Selection with the SWXTL-AA DLT Tape Drive.....	C-1
C.1	Density Selection	C-1
C.2	Density Selection Rules.....	C-1

Figures

1-1	Front Panel of 6.0-GB DLT Cartridge Tape Drive	1-2
1-2	CompacTape III Cartridge	1-3
1-3	CompacTape III Cleaning Tape	1-4
2-1	SWXTL-AA Tape Drive SCSI ID Switches	2-2
2-2	Installing the SWXTL-AA into an Expansion Storage Pedestal	2-4
2-3	Tape Drive Front Panel Controls and Indicators	2-5
3-1	Front Panel Layout of 6.0-GB DLT Cartridge Tape Drive	3-2
3-2	CompacTape III Data Tape Cartridge	3-7
3-3	Loading Cartridge Into Tape Drive	3-9
3-4	Unloading Cartridge From Tape Drive	3-10
4-1	Checking Out Cartridge Leader	4-4
4-2	Correct Engagement of Take-Up Leader in Tape Drive	4-4
4-3	Correct and Incorrect Positions of Tape Drive Leader	4-5

Tables

1-1	Ordering Numbers for Cleaning Tape and Data Tapes	1-5
2-1	SWXTL-AA Tape Drive SCSI ID and Parity Switch Settings	2-3
3-1	Right-side Front Panel Indicators and Controls	3-3
3-2	Operating States of 6.0-GB DLT Cartridge Tape Drive Unit Following Initialization	3-5
3-3	Tape Drive LED Status	3-6
3-4	Moving Write-Protect switch Before Tape Drive Operation	3-7
3-5	Moving Write-Protect switch During A Read/Write Operation	3-8
3-6	What is Happening During Cartridge Use (Right-Side Indicators)	3-9
3-7	When To Use the Cleaning Cartridge	3-11
4-1	Possible Corrections for Common Error Situations	4-2
4-2	Troubleshooting Table	5-6
A-1	6.0-GB DLT Cartridge Tape Drive Specifications	A-1
C-1	Cartridge Compatibility with the SWXTL-AA Tape Drive	C-1

Revision Record

This Revision Record provides a concise publication history of this guide. It lists the manual revision levels, release dates, and reasons for the revisions. It also describes how the changes to affected pages are marked in the guide.

The following revision history lists all revisions of this publication and their effective dates. The publication part number is included in the *Revision Level* column, with the last entry denoting the latest revision. This publication supports the StorageWorks SWXTL-AA 6.0-GB DLT Cartridge Tape Drive SBB.

Revision Level	Date	Summary of Changes
EK-SM1TD-UG. A01	July 1994	Original release

About This Guide

This section identifies the users of this guide and describes the contents and structure. In addition, it includes a list of conventions used in this guide.

This guide provides a product overview, installation, operation, and maintenance information for the StorageWorks SWXTL-AA 6.0-GB DLT Cartridge Tape Drive Storage Building Block (SBB).

Intended Audience

This guide is intended for people who will install, operate, and maintain the StorageWorks SWXTL-AA SBB.

Document Structure

This guide contains the following chapters:

Chapter 1. Introduction

Chapter 1 gives an overview of the 6.0-GB DLT Cartridge Tape Drive, describes its components, and discusses the drive features. This chapter provides a product overview of the 6.0-GB DLT Cartridge Tape Drive and identifies design features (including basic components and performance considerations). The chapter also includes overview descriptions of the data tape and cleaning tape cartridges used with this equipment, defining the basic functions of each, and identifies what is supplied with the tape drive unit.

Chapter 2. Installation and Operation of the SWXTL-AA SBB Tape Drive in a Storage Subsystem

Chapter 2 provides specific details pertaining to the SWXTL-AA SBB Tape Drive, which is designed to be operated in a Digital StorageWorks Expansion Storage Pedestal subsystem. This chapter describes how to unpack the received drive, how to prepare the drive for installation in the pedestal, how to set the SCSI ID of the tape drive, how to install the device into a StorageWorks Expansion Storage Pedestal subsystem, and how to confirm operation integrity by performing the Power On Self Test (POST) exercise.

Chapter 3. Operation

Chapter 3 describes the SWXTL-AA tape drive's LED indicators and how to use them to monitor tape drive operation. This chapter identifies the switches and LED indicators on the front panel of the 6.0-GB tape drive, describes how to use them (including operation of the power-on self-test (POST)), provides use rules for the CompacTape III DLT cartridge data and cleaning tapes, gives detailed procedures for correct loading and unloading of the tape cartridges, and explains how to select a desired density format for recording.

Chapter 4. Maintenance

Chapter 4 describes how to clean the heads of the tape drive and provides a troubleshooting table to help diagnose common problems. This chapter describes preventive maintenance and general troubleshooting for the 6.0-GB DLT Cartridge Tape Drive.

Appendix A. Specifications

Appendix A lists the physical, electrical, cooling, environmental, and environmental stabilization specifications for the tape drive.

Appendix B. Product Notes for Novell™ and MS-DOS™

Appendix B provides information for the system administrator about interfacing the 6.0-GB DLT Cartridge Tape Drive with a host system operating under the Novell, MS-DOS, or MS/DOS/WINDOWS operating systems.

Appendix C. Density Selection with the SWXTL-AA DLT Tape Drive

Appendix C provides information for the system administrator with respect to switching of the SWXTL-AA drive between two density states (applicable only to application software capable of supporting both states).

Conventions

This guide uses the following conventions:

Documentation Conventions

Style	Meaning
boldface type	For emphasis
<i>italic type</i>	<i>For emphasis and manual titles</i>

Introduction

This chapter provides a product overview of the Model 6.0-GB DLT Cartridge Tape Drive Storage Building Block (SBB) and identifies design features (including basic components and performance considerations). The chapter also includes overview descriptions of the data tape and cleaning tape cartridges, defining the basic functions of each, and identifies what is supplied with the tape drive.

1.1 Product Overview

The StorageWorks SWXTL-AA Model 6.0-GB DLT Cartridge Tape Drive Storage Building Block (SBB) is a streaming tape drive which connects to a SCSI bus. This device can store up to 6.0 GB of data. The primary uses for this drive are data backup, data archiving, and loading software onto computer systems.

1.2 Design Features

Figure 1–1 shows a view of the front panel, which provides status indicators for system operation, along with an access door for inserting and removing the CompacTape III tape cartridge.

NOTE

The SWXTL-AA unit is shipped with decals providing equivalent wording for all front-panel labeling in different major languages. The decals adhere to the cartridge insert/release handle and to the indicator panel, covering the original English text stenciled on the equipment. Illustrations in this manual show the English version of the text, with no decals affixed.

1.2.1 Basic Components

The 6.0-GB DLT Cartridge Tape Drive has an integrated SCSI controller module, which connects to the associated computer system through a SCSI bus attached to that controller module. The controller module is responsible for processing SCSI commands and for initiating tape drive operations. The connection to the SCSI bus is made through the StorageWorks Expansion Storage Pedestal, as discussed in Chapter 2.

1.2.2 Performance Considerations

The performance you can achieve with the 6.0-GB DLT Cartridge Tape Drive can depend on a number of considerations, including your system processor. This tape drive theoretically can back up 2.9 GB of data per hour (tape streaming at maximum speed). In a host-based

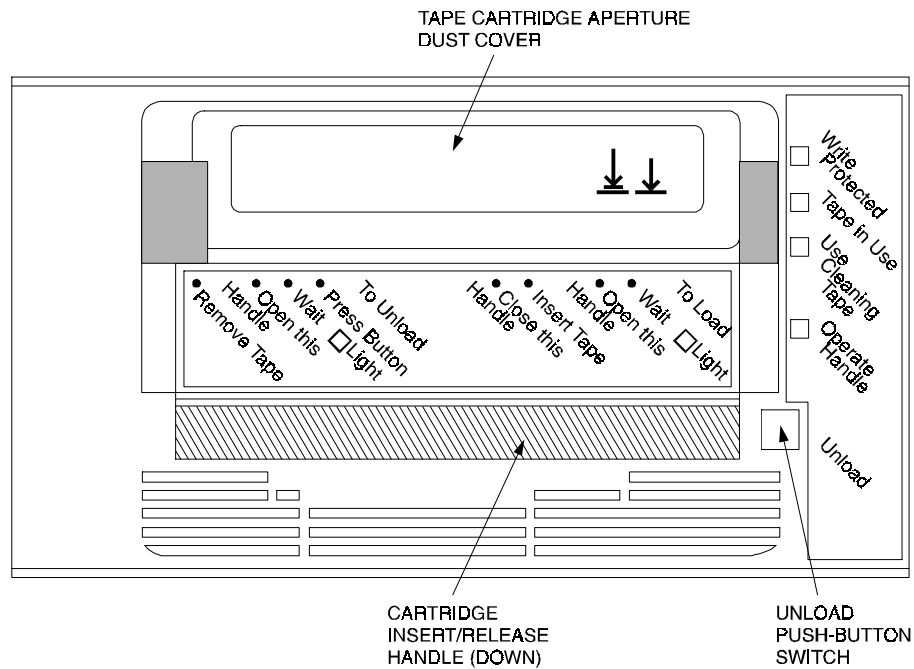
Figure 1–1 Front Panel of 6.0-GB DLT Cartridge Tape Drive

TZ86-001

configuration, proper choice of system processor, cache, hard drive, adapters, and backup software can help to approach this throughput rate. Host SCSI IO or other computer-intensive operations on the host CPU will tend to reduce throughput to tape, however.

When data is being passed to or from client workstations in a client-server environment, additional parameters having to do with reduced local area network bandwidth, network traffic, or lower client workstation performance characteristics will tend to reduce maximum throughput to the tape drive.

1.3 Data Tape

1.3.1 CompacTape III Description

The CompacTape III cartridge is a 4-1/8-inch square, dark gray, plastic cartridge, containing 1200 feet of 1/2-inch magnetic, metal particle (MP) tape. A write-protect slide switch on the front surface lets you select between two positions: WRITE-ENABLED (switch moved to the right), which lets the tape drive write data on the tape, and WRITE-PROTECTED (switch moved to the left), which prevents the tape drive from writing over data you want to preserve (See Figure 1–2).

1.3.2 Cartridge Packaging

Your CompacTape III cartridge comes supplied with:

1. A set of slide-in labels
2. A cartridge-handling information sheet

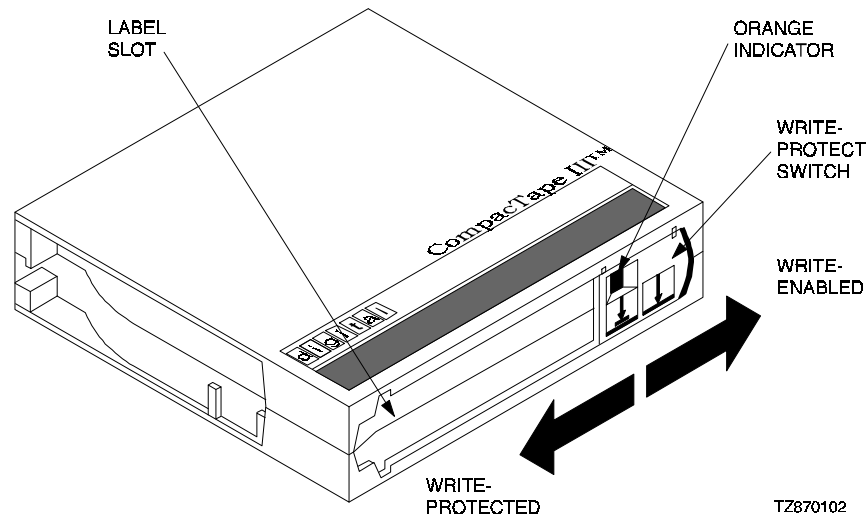
Figure 1–2 CompacTape III Cartridge

1.4 Reading and Writing Data

The 6.0-GB DLT Cartridge Tape Drive writes 56 pairs of tracks — 112 tracks total — on the CompacTape III tape. The drive reads and writes data in a two-track parallel, serpentine fashion, traveling the entire length of tape on two tracks (at about 100 inches per second). The drive then steps the head, reverses tape direction, and continues to read/write on the next two tracks, repeating this same process for a total of 56 times per tape, and processing the entire tape in slightly more than an hour.

1.4.1 Write-Protecting Data

The CompacTape III cartridge has a write-protect slide-bar switch on its front surface that lets you prevent accidental erasure of data. When you move that switch to the left, so that a small orange rectangle is visible in the aperture over the left arrow symbol on the switch (see Figure 2–2), the tape is write-protected and data cannot be written to the tape. When you move the switch to the right, so that no orange color shows in the rectangular aperture, the tape is write-enabled, and the tape drive can write to the tape. The symbols on the slide-bar switch indicate this function by depicting data flow as a downward-pointing arrow and the tape medium as a horizontal line below the arrow's point. The arrow on the left side of the slide-bar switch depicts a barrier line between the data-flow arrow and the tape; this symbolizes that the data cannot reach the tape when the switch is moved to the left. No such barrier line appears below the arrow on the right side of the switch, indicating that data can flow to the tape when the switch is moved to the right.

1.5 Cleaning Tape

1.5.1 CleaningTape III Description

The CleaningTape III cartridge is a 4-1/8-inch square, light yellow, plastic cartridge containing 1200 feet of 1/2-inch cleaning tape (see Figure 1–3). For information on using the CleaningTape III cartridge, refer to Section 3.5.7 and/or Table 3-7.

1.5.2 CleaningTape III Packaging

Your CleaningTape III cartridge comes supplied with:

1. A slide-in label containing 20 boxes, to be checked off following each sequential use of the CleaningTape III cartridge (refer to section 1.5.3).
2. A cartridge-handling information sheet.

1.5.3 CleaningTape III Cartridge Expiration

Each use of the CleaningTape III cartridge uses up some of the cleaning area on the tape. You can use the CleaningTape III cartridge approximately 20 times before the cleaning area is fully used up. After that many uses, the cartridge will be ineffective and must be replaced with a new cartridge.

Figure 1–3 CompactTape III Cleaning Tape

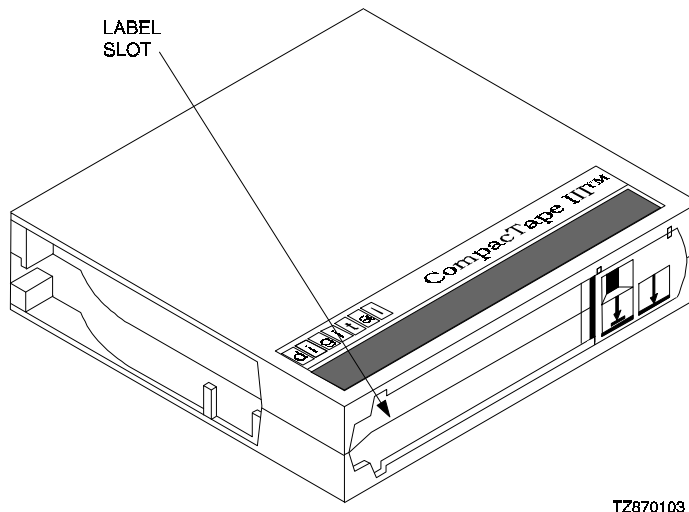

To keep track of the number of times the tape has been used, mark a checkmark in one of the 20 boxes on the cartridge label after each cleaning. After all 20 boxes have been checked off, the cartridge should be considered as expired, and you should discard that cartridge and replace it with a new one.

1.6 Supplies

1.6.1 Cartridges Provided

One CompacTape III cartridge and one CleaningTape III cartridge come with each 6.0-GB DLT Cartridge Tape Drive, in the shipping package.

1.6.2 How To Order Replacement Cartridges

You can order additional cartridges by contacting your Digital reseller or by calling Digital's DECdirect ordering service at 1-800-DIGITAL in the U.S.A.; in Canada, call 800-267-6215.

Table 1-1 lists ordering numbers for various quantities of cartridges for the 6.0-GB DLT Cartridge Tape Drives:

Table 1-1 Ordering Numbers for Cleaning Tape and Data Tapes

Order Number	Description
TK85-HC	CleaningTape III Head Cleaning Cartridge
TK85K-01	CompacTape III Data Cartridge (quantity, 1)
TK85K-07	CompacTape III Data Cartridge (quantity, 7)
TK85K-A1	CompacTape III Data Cartridge (quantity, 945)

Installation and Operation of the SWXTL-AA SBB Tape Drive in a Storage Subsystem

This chapter provides specific details pertaining to unpacking, preinstallation setup, installation, and POST operational testing of the SWXTL-AA 6.0-GB DLT Cartridge Tape Drive Storage Building Block (SBB), which is designed to be operated in a Digital StorageWorks Expansion Storage Pedestal.

2.1 Introduction

The SWXTL-AA SBB Tape Drive is housed in an SBB storage carrier and is designed for installation into a StorageWorks Storage Expansion Pedestal subsystem. The drive occupies three adjacent slots in the storage subsystem and is configured as one of up to seven devices on the SCSI bus. This chapter describes how to unpack the received drive, how to prepare the drive for installation, how to set the SCSI ID of the tape drive, how to install the device into a StorageWorks Expansion Storage Pedestal subsystem, and how to perform the Power On Self Test (POST) procedure.

The information in this chapter is divided as follows:

- Unpacking
- Preinstallation setup of the drive (selecting SCSI ID address and parity of the tape drive)
- Installation into the storage subsystem
- POST test

2.2 Unpacking

Unpack and inspect the contents of your shipment. It should contain the following items:

- This guide
- One Model 6.0-GB DLT Cartridge Tape Drive
- One blank CompacTape III data cassette tape cartridge
- One CleaningTape III head-cleaning cartridge
- One StorageWorks [Tx86 Tape Drive Operator's Reference Card](#)

Also, check the contents for damaged components. Notify your vendor immediately if any items are damaged. Keep all boxes and packing material for reshipment.

2.3 Preinstallation Procedures

Perform the following procedure before installing the 6.0-GB DLT Cartridge Tape Drive.

2.3.1 Setting the SCSI ID Address of the Tape Drive

A SWXTL-AA tape drive SBB occupies three adjacent slots in the pedestal, where the mounting slots are numbered 0 through 7, from top to bottom, with the power supply occupying slot 7. Since the backplane interface that connects the SWXTL-AA tape drive SBB to the SCSI bus and power connections via the pedestal is located at the top of the unit (refer to Figure 2–1), you physically can use any of slots 0 through 4 in the pedestal.

The SWXTL-AA SBB does not have an automatic SCSI address setting; its SCSI ID must be set manually by use of the SCSI ID switches on the rear of the SWXTL-AA SBB Tape Drive. This means that you can install the SBB unit in any available location and set the SCSI ID switches to get any desired logical SCSI address, as delineated in Table 2-1. Since the switches are on the rear panel, you must set the desired address before installing the tape drive SBB in the pedestal subsystem.

Figure 2–1 SWXTL-AA Tape Drive (Rear View, Showing Location of Backplane Interface Connector and SCSI ID Switches)

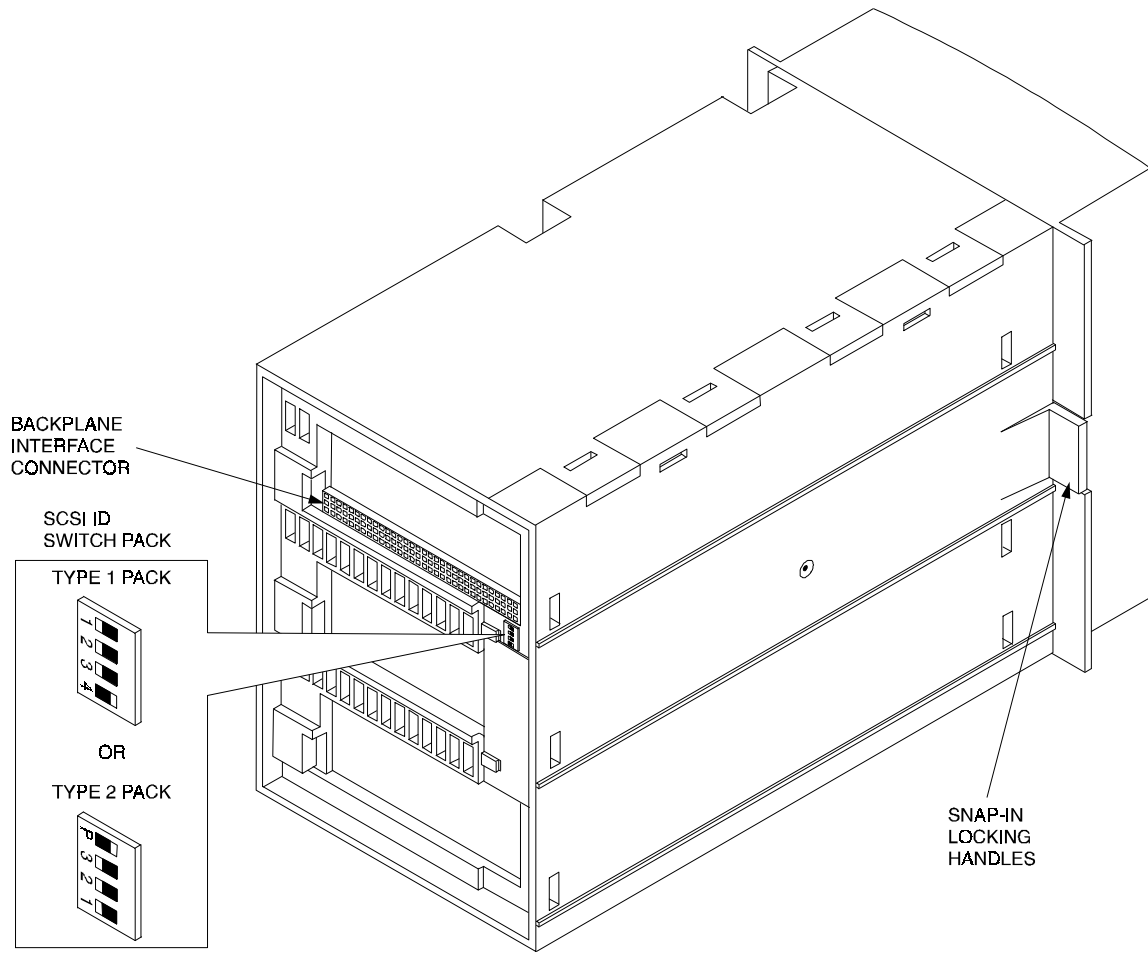

TZ86-005A

2.3.2 Parity Checking

The top-most switch on the SCSI ID switch pack located on the rear of the SWXTL-AA tape drive (Switch SW-1 on units with Type 1 switch packs, Switch SW-P on units with Type 2 switch packs) lets you choose between ODD parity (switch set to the left, or off) and EVEN parity (switch set to the right, or on).

NOTE

The terms “left” and “right” (and “top” and “bottom”) as used here and in Table 2–1 refer to the orientation of the switches when the unit is in its normal pedestal mounting position, lying on its right side, as shown in Figure 2–1.

Table 2–1 SWXTL-AA Tape Drive SCSI ID and Parity Switch Settings

SCSI Code Address	Switch Type 1 (Top to Bottom)				Switch Type 2 (Top to Bottom)			
	SW-1	SW-2	SW-3	SW-4	SW-P	SW-3	SW-2	SW-1
0	—	Left	Left	Left	—	Left	Left	Left
1	—	Right	Left	Left	—	Right	Left	Left
2	—	Left	Right	Left	—	Left	Right	Left
3	—	Right	Right	Left	—	Right	Right	Left
4	—	Left	Left	Right	—	Left	Left	Right
5	—	Right	Left	Right	—	Right	Left	Right
6	—	Left	Right	Right	—	Left	Right	Right
7*	—	Right	Right	Right	—	Right	Right	Right
Even Parity	Left	—	—	—	Left	—	—	—
Odd Parity	Right	—	—	—	Right	—	—	—

* Normally reserved for host.

2.4 Installing the SWXTL-AA SBB Tape Drive Into A StorageWorks Expansion Storage Subsystem

CAUTIONS

Refer to the applicable documentation for your host computer and/or your specific operating system before installing the drive. This installation procedure assumes that you have already installed and appropriately cabled the StorageWorks Storage Expansion Pedestal and have checked out that subsystem as applicable, so that it is ready to receive this SBB unit.

You install the SWXTL-AA SBB tape drive in a storage subsystem by inserting the drive so that the backplane interface connector on the upper portion of the rear surface fits into an available SCSI device storage slot. Since the tape drive SBB occupies three adjacent slots, this means any of slots 0 through 4, as the pedestal power supply is always mounted in slot 7. Regardless of which slots you use, the unit will be identified as being whichever device you set the SCSI ID switches for on the rear surface. The drive can be installed using the *hot-swap* method where the drive is installed with the host system powered on and operating, or

with the host system powered off. Before using the *hot-swap* method, consult your system administrator to ensure that your operating system supports this type of installation.

To install the tape drive:

1. Open the door on the front bezel of the StorageWorks Expansion Storage Pedestal subsystem (refer to Figure 2–2) and remove the bezel by pressing down on the plastic locking tabs at the bottom inside surface of the bezel (just in front of the power supply) and then pulling the bottom of the bezel forward and upward to lift the entire bezel assembly free.
2. Remove the filler panel (or other SBB) from the desired three adjacent device slots in the storage subsystem by squeezing the locking handles at the ends of each respective panel (or SBB) and removing the panel (or SBB).
3. Install the tape drive in the open slot, sliding the drive in firmly until its locking handles snap into place.
4. Perform the POST test, as described in the following subsection, to verify the operational integrity of the drive.

Figure 2–2 Installing the SWXTL-AA into an Expansion Storage Pedestal

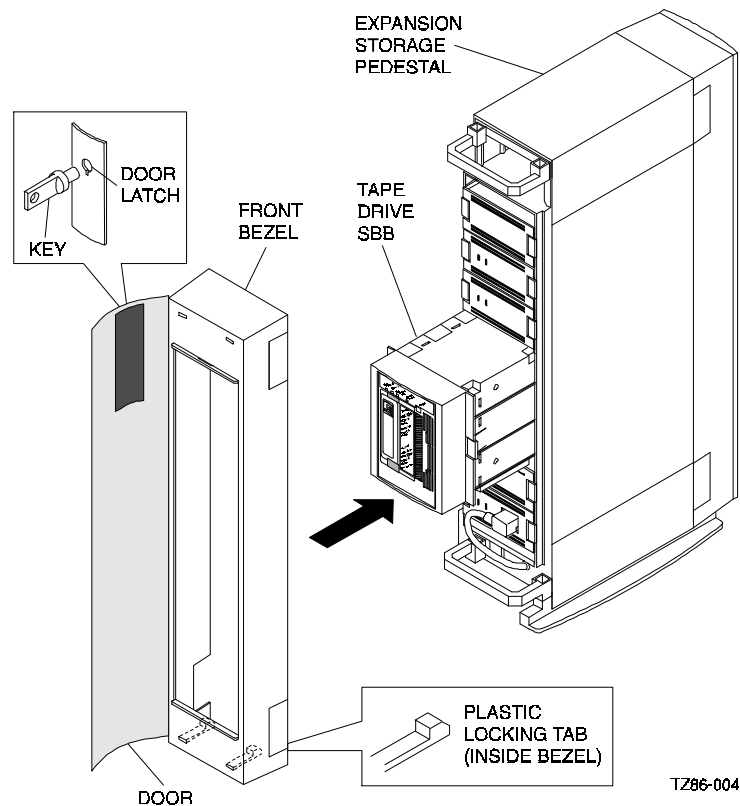

2.5 Power On Self Test (POST)

The power-on self-test (POST) exercise verifies the proper installation of the tape drive. The test may be performed with the host computer powered on, if your operating system permits, or with the SCSI bus either connected or disconnected. Refer to Figure 2–3 for the locations

of the front panel LED indicators on the drive. To execute the power-on self-test, proceed as follows:

NOTE

If the WRITE-PROTECTED indicator flashes orange and the TAPE IN USE indicator flashes yellow continuously for more than 30 seconds in the following test, the POST test has failed. Repeat the test to clear the failure (power off and then on). If the test still fails, replace the drive.

Figure 2-3 Tape Drive Front Panel Controls and Indicators

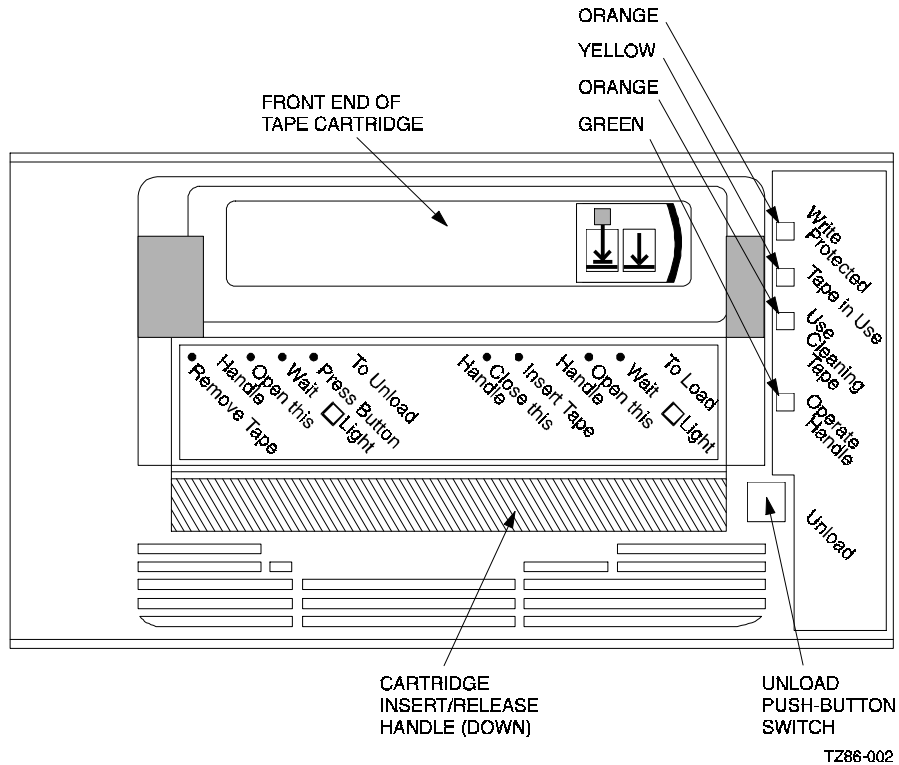

1. Ensure that there is no cassette tape in the drive.
2. Power on the 6.0-GB DLT Cartridge Tape Drive device, either by cycling the pedestal subsystem power switch off and on or, if other SBB units in that subsystem are active and should not be powered down, by hot-swapping the SBB unit under test (i.e., pull it free from the pedestal and then slide it back into its operating position).
3. Observe all four right-side indicators then lighting sequentially, from top to bottom.
4. All four right-side panel indicators should remain lighted for 3 to 5 seconds, after which the green OPERATE HANDLE indicator and the two orange indicators should go out, leaving only the yellow TAPE IN USE indicator active.
5. The yellow TAPE IN USE indicator should continue to blink for a few seconds while the tape mechanism searches for a tape and then go out.

6. An internal beeper should sound to alert the operator and the green OPERATE HANDLE indicator should become steadily lit to indicate that the door latch is released and that the cartridge insert/release handle can be pulled up to allow insertion of a tape.
7. Load a cassette tape into the drive and observe the TAPE IN USE indicator. That yellow indicator initially should blink momentarily at 1-second intervals after the handle is closed (pushed down) as the tape drive engages the tape, then double-blink at the same interval while the tape is being moved to the correct position. Depending on whether this is a new tape or a tape with some previously recorded data, this blinking period should extend for from 20 seconds to a few minutes after the cassette is loaded, until the tape has reached the applicable position for recording new data, after which the TAPE IN USE indicator should remain steadily on.
8. After the unit passes POST, connect the subsystem to your host computer through appropriate SCSI interface cables, and then have your system administrator assign a device name to the drive, if applicable.

NOTE

If you are connecting the SBB tape drive to a fast, single-ended SCSI bus, the interface cable cannot exceed three meters (9.8 feet). If you are connecting the tape drive to a slow, single-ended SCSI bus, the interface cable can be up to 6 meters (19.7 feet) in length. In both cases, this maximum cable length includes not only the length of cable from the pedestal subsystem to the host computer but also the length of cable internal to the subsystem (including the backplane) and the length of cable internal to the host computer.

Front-Panel Controls & Indicators and Operation of the SWXTL-AA 6.0-GB DLT Cartridge Tape Drive SBB

This chapter identifies the switches and LED indicators on the front panel of the 6.0-GB DLT Cartridge Tape Drive, describes how to use them (including operation of the power-on self-test (POST), provides use rules for the CompactTape II cartridge data and cleaning tapes, gives detailed procedures for correct loading and unloading of the tape cartridges, and explains how to select a desired density format for recording.

3.1 General

Digital's 6.0-GB-family of DLT Tape Drives offer outstanding performance and data integrity, combined with ease of use. All normal-use operator controls are mounted on the front panel, consisting of two push-button switches, a pull-down handle, and several color-differentiated LED indicators to indicate operational status at any given time. The drive uses these indicators to "report" when the unit is ready for a tape, data format of the tape currently mounted, when the heads need to be cleaned, and when it is safe to take a tape out of the drive, as well as whether or not the tape cartridge currently is write-protected.

3.2 Front-Panel Controls and Indicators

All operating controls are located on the front panel (refer to Figure 3-1).

3.2.1 Tape Status Indicators

The right-side front panel of the tape cassette drive contains four indicators (WRITE PROTECTED, TAPE IN USE, USE CLEANING TAPE, and OPERATE HANDLE LEDs) and one push-button switch (UNLOAD push-button). Table 3-1 explains the function of each of these indicators, along with the associated Unload push-button switch, also located on the right side.

3.2.2 Unload Push-Button

CAUTION

Pressing the UNLOAD push-button during normal tape operations may halt the tape and result in the loss of data.

Figure 3–1 Front Panel Layout of 6.0-GB DLT Cartridge Tape Drive

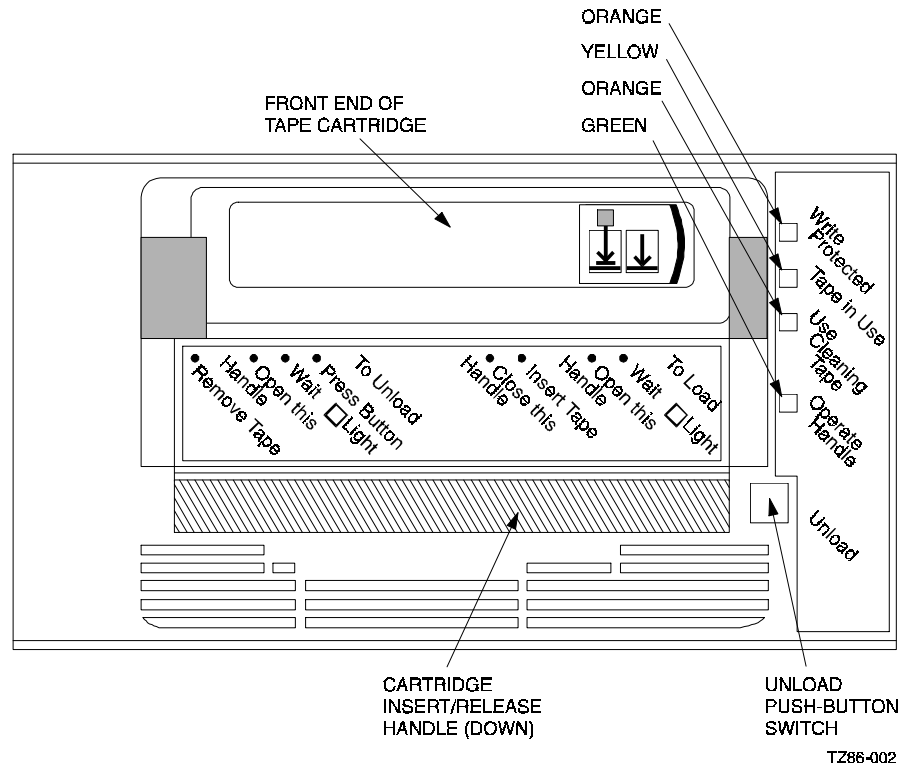

Activation of the Unload push-button causes the tape drive to rewind the tape and then unload the tape from the tape drive mechanism back into the cartridge. The tape must be completely rewound and unloaded into the cartridge before you remove the cartridge from the drive. Depending on the tape position when you press the UNLOAD push-button, an unloading operation may take from 10 seconds up to 4 minutes.

In the event that the tape drive is writing data to the tape when you press the UNLOAD push-button, the 6.0-GB tape drive flushes any buffered write data to the medium before beginning the unloading sequence.

If the drive is in error state (all four right-side panel indicators flashing), pushing the UNLOAD push-button causes the tape drive to reset and unload the tape, if possible.

3.2.3 Cartridge Insert/Release Handle

The cartridge insert/release handle provides simplified tape loading and unloading procedures, printed on the handle. This handle must be pulled up and forward in order for a tape cartridge to be loaded or removed, as described in the following procedures, but must not be actuated unless the green OPERATE HANDLE indicator is lit. (See Section 3.5.4 for cartridge loading procedures, Section 3.5.6 for cartridge unloading procedures.)

3.3 Power-On Self-Test (POST)

The POST (Power-On Self-Test) test, which is performed automatically whenever power is applied to the 6.0-GB tape, verifies operational integrity of the tape drive. Basic operation of

the POST exercise was delineated in Section 2.5 as part of the installation procedure, but is repeated here in more detail, to cover all possibilities. The operation may be performed with the host system power on (if your operating system permits) or off, and with the SCSI bus connected or disconnected. (Refer to Figure 3–1 for the locations of the front panel switches and LED indicators on the drive.)

Table 3–1 Right-side Front Panel Indicators and Controls

Label	Color	State	Operating Condition or Function
Write Protected	Orange	On	Loaded tape is write-protected.
		Off	Loaded tape is write-enabled.
Tape in Use	Yellow	On	Tape is loaded, ready for use.
		Blinking	Tape is moving.
Use Cleaning Tape	Orange	On	Drive heads need cleaning, or else current data cartridge is bad.
		Remaining on after you unload cleaning tape.	The cleaning tape tried to clean the drive heads, but was expired (insufficient cleaning area), so heads were not adequately cleaned.
		Turns on again when data cartridge is loaded after cleaning. Off	Data cartridge may be defective; try another cartridge. Cleaning is complete or unnecessary.
OPERATE HANDLE	Green	On	Cartridge insert/release handle is unlocked and can be operated.
		Off	Cartridge insert/release handle is locked. Do not operate handle.
UNLOAD		Recessed (pushed in)	Used to unlock the tape cassette door handle (press and hold for 1 to 2 seconds).
		At rest (out)	Normal inactive condition for this spring-loaded push-button switch.
All right-side front panel indicators		On (simultaneously)	Power-on self-test is starting.
		Blinking	An error has occurred. Press the Unload push-button or turn drive power off and then on again to clear the error.

NOTE

If the WRITE-PROTECTED indicator flashes orange and the TAPE IN USE indicator flashes yellow continuously for more than 30 seconds in the following sequence, then the POST test has failed. Repeat the test to clear the failure (power off and then on). If the test still fails, replace the drive.

To execute the power-on self-test sequence, proceed as follows:

1. Power on the tape drive: turn on pedestal power or else pull the SBB tape drive out and then push it back into place).
2. Observe that all four indicators light sequentially, from top to bottom.
3. All four panel indicators should remain lighted for 3 to 5 seconds and then the green Operate Handle indicator and the two orange indicators should go out, leaving only the TAPE IN USE indicator active. That yellow indicator should continue to blink for a few more seconds while the tape mechanism searches for tape. Subsequent indicator activity depends on whether or not a tape cartridge currently is mounted in the tape drive, as defined in Table 3–2. (If no tape is present, the TAPE IN USE indicator continues to blink until the applicable point for recording new data is under the recording head, at which time that indicator becomes steadily lit. If no cartridge is mounted, the Tape in Use indicator goes out, a transducer inside the unit beeps to alert you, and the green OPERATE HANDLE indicator becomes steadily lit to indicate that the door latch is released and that you can pull up the cartridge insert/release handle to allow insertion of tape.)

Following initialization, the drive is in one of the four states defined in Table 3–2.

NOTE

Under normal conditions, you should not power up a tape drive with a tape cartridge mounted, so that only conditions **a** and **d** in Table 3–2 would apply. The two intervening conditions, describing situations in which a tape was already mounted before power was applied, are included to cover emergency situations.

3.4 Status Indication of Tape Drive LEDs

The status of the tape drive under different conditions is indicated by the WRITE PROTECTED and TAPE IN USE LEDs. In the normal operating state, the WRITE PROTECTED LED only indicates the write-protect status and the TAPE IN USE LED only indicates the drive activity and load status. Table 3–3 describes the status conditions represented by the LEDs. Refer to Figure 3–1 to identify the LEDs on the front panel.

3.5 CompactType III DLT Tape Cassette

The tape cassette contains a write-protect slide-bar switch (Figure 3–2) which is the same color as the body of the tape cassette but exposes an orange area in a rectangular aperture above the arrow on the left side of that switch when in the write-protect position. To "write-protect" the tape, slide the tab to the left before loading the tape in the drive or before starting any write operations. To "write-enable" the tape, slide the switch to the right before loading the tape in the drive or before any write operations.

3.5.1 Using and Handling CompactType III Tape Cassettes

The data tape cartridge is a 4-1/8-inch, gray, plastic cartridge containing 1200 feet of 1/2-inch magnetic metal particle tape. The medium is a half-inch cartridge or ANSI-compatible

equivalent. It is written and read using the interchange format proposed in the applicable pending ANSI X3B5 project.

Table 3–2 Operating States of 6.0-GB DLT Cartridge Tape Drive Unit Following Initialization

	Starting Condition	Status Light Sequence
a.	If no tape cartridge is mounted in drive and the drive passes POST:	(1) The yellow TAPE IN USE light turns off. (2) The internal audio-transducer alarm beeps. (3) The green OPERATE HANDLE light turns on. (4) The handle is unlatched. You can now raise the handle and insert a tape cartridge into the drive.
b.	If a cartridge is present in the drive and the cartridge insert/release handle is <u>down</u> . ¹	(1) The drive loads the tape cartridge. (2) The yellow TAPE-IN-USE light blinks while the tape is mounting and then lights steadily.
c.	If a cartridge is present in the drive and the cartridge insert/release handle is <u>up</u> . ²	(1) The yellow TAPE IN USE light turns off. (2) The internal audio transducer beeps. (3) The green OPERATE HANDLE light flashes. When you lower the handle, the cartridge loads.
d.	If the drive detects an error condition.	All indicators blink repeatedly. Try to unload the tape and reinitialize the drive by pressing the Unload push-button or by turning drive power off and then on again or by hot-swapping the tape drive. If you do this, the indicators stop blinking and the drive tries to reinitialize; if the attempt succeeds, the indicators momentarily turn on steadily again and then go off.

¹ Not recommended. Shutting down power while a tape cartridge is still mounted in the drive can result in damage either to the tape cartridge (and/or its data) or to the drive, itself.

² Not recommended.

To ensure optimal performance from your cassettes tapes, observe the following guidelines when using and handling the tapes.

- Avoid placing the tape cassettes near sources of electromagnetic radiation such as terminals, video, or X-ray equipment. Radiation from this type of equipment can erase or corrupt data on the tape
- Keep tape cassettes out of direct sunlight and away from heaters and sources of heat
- Store tape cassettes and cleaning cassette at room temperatures between +5°C and +32°C (40°F through 90°F)
- Store cassettes in a dust-free environment where the relative humidity is within the range from 20% to 60%

Table 3–3 Tape Drive LED Status

Status	WRITE PROTECTED LED	TAPE IN USE LED
No tape loaded.	Off	Off
Tape loaded, write enabled.	Off	Yellow
Tape loaded, write-protected.	Orange	Yellow
No SCSI/drive activity.	Off†	Yellow (steady)
SCSI/drive activity.	Off†	Blinks on and off to track activity
Load sequence.	Off†	Blinks yellow @≈1-second interval (25% on). Yellow continuously when done. Indicates drive activity.
Unload sequence	Off†, goes off.	Flashes yellow @≈1-second interval (25% on). Goes off when done. Indicates drive activity.
Reset sequence	Orange Off†	Yellow, blinking. Normal indications.
Power on self test (POST)	Flashes orange @ 2 Hz for first few seconds, then goes off for remainder of power-up test sequence.	Double-flashes yellow @≈1-second interval for length of test. Normal activity indications when test complete.
Test complete, no failure.	Resume normal operation, off†.	
Test failure, drive fault.	Flashes orange @ 2 Hz.	Double-flashes yellow @≈1-second interval.

† If cassette is write-protected, orange WRITE-PROTECTED LED will light.

NOTE

You can order the data cartridge (Part No. TK85-01) and/or the cleaning cartridge (Part No. TK85-HC) from your reseller or by calling DECdirect at 800-DIGITAL in the U.S.A. or 800-27-6215 in Canada. (Refer to Table 1-2 for quantity-order part numbers.)

CAUTION

Appropriate label cards are supplied with each tape cartridge. Always place the label in the recessed area on the cartridge. Never affix a label over another label. Also, please note that any substitute media must meet ANSI X3B5 certification requirements.

3.5.2 Write-Protect Switch

The tape cartridge has a write-protect slide-bar switch on the right side of its front surface so that you can prevent the accidental overwriting of data stored on the tape (see Figure 3–2). To read or copy from the tape cassette, slide the write-protect bar-switch to the left, so that an orange area is exposed in the rectangular aperture directly over the left-side arrow on the

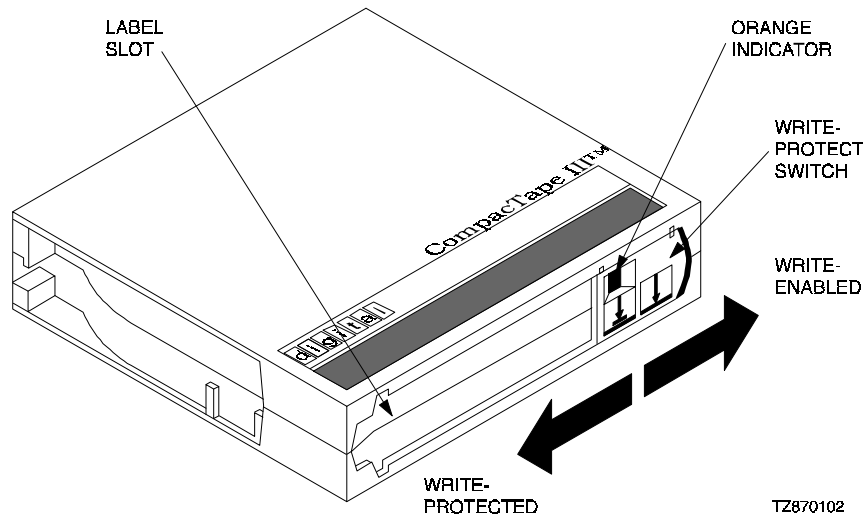
Figure 3–2 CompacTape III Data Tape Cartridge

switch, indicating that the tape is in its “write-protected” state. This prevents writing to the tape and ensures that data will not be accidentally overwritten. Use the following guidelines when setting the write-protect tab:

- If you are reading data (copying from tape), set the write-protect tab to “Write Protected” (to the left, orange area showing).
- If you are writing data (writing to tape), set the write-protect tab to “Write Enabled” (to the right, orange area not showing).
- When loading a tape cassette into the drive, make sure the cassette's write-protect tab is on the right, facing you.

3.5.3 Data Protection

If you move the cartridge write-protect switch to the left, the drive turns on the WRITE PROTECTED LED immediately. If the drive is writing to the tape when you move the switch, however, write-protection does not take effect until that write has been completed.

Table 3–4 describes what happens to data protection when you move the write-protect switch before loading the cassette.

Table 3–4 Moving Write-Protect switch Before Tape Drive Operation

If you move the Write Protect switch ...	Then ...
To the left, with the orange area showing through the aperture above the left arrow symbol on the switch ...	The tape drive cannot write data to the tape.
To the right, with no orange area showing in the aperture above the left arrow on the switch ...	The tape drive can write data to the tape (if the tape is not software write-protected).

Table 3–5 describes what happens with respect to data protection when you move the write-protect switch during operation:

Table 3–5 Moving Write-Protect switch During A Read/Write Operation

If you move the Write Protect switch ...	Then ...
From the write-protected position (left) to the write-enabled position (right, no orange area showing in aperture above left arrow symbol) ...	The tape becomes write-enabled <u>after</u> a variable amount of time (in the order of seconds).
From the write-enabled position (right) to the write-protected position (left, orange area showing in aperture) ...	The tape becomes write-protected after a variable amount of time (in the order of seconds, unless write operation is in process, in which case the effect does not become active until that write operation is completed).

3.5.4 Loading A Cartridge

The cartridge insert/release handle on the front of the drive provides outline procedures for loading a cartridge into the tape drive (right side of handle) and unloading a cartridge from the drive (left side of handle). The following is a more detailed version of the procedure for loading a cartridge (refer to Figure 3–3).

CAUTION

Never operate the cartridge insert/release handle unless the green Operate Handle indicator is steadily lit.

1. When the green OPERATE HANDLE indicator is steadily lit, pull the cartridge insert/release handle open by pulling the bottom edge up and forward.
2. Insert the rear end of the cartridge (opposite from the surface containing the write-protect switch) into the aperture behind the handle, right side up (name on top, with arrows on write-protect switch on front pointing down).
3. Push the cartridge assembly into the drive until the cartridge reaches its full-stop position, with the cartridge fully pressed into the unit.
4. Push the insert/release handle closed by pushing front edge back and down.

After the door becomes closed, the green OPERATE HANDLE indicator goes out and the yellow TAPE IN USE indicator blinks to show that the tape is loading. When the tape is at the BOT (Beginning Of Tape) marker, the yellow TAPE IN USE indicator lights steadily. The tape is then ready for use.

3.5.5 Tape in Use

When the yellow TAPE IN USE light is on steadily, the tape is ready for use. While the tape is being read, written to, or rewound, the yellow TAPE IN USE indicator blinks. Table 3–6 describes what is happening during cartridge use:

Figure 3-3 Loading Cartridge Into Tape Drive

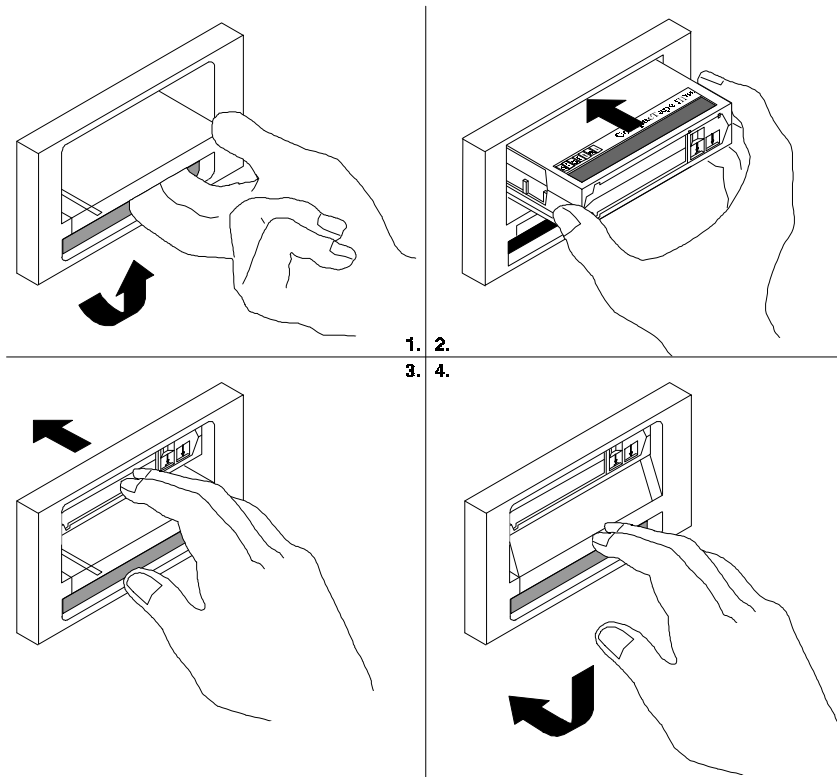

TZ870303

Table 3-6 What is Happening During Cartridge Use (Right-Side Indicators)

	If ...	It means ...
1.	The yellow TAPE IN USE indicator is on steadily	A cartridge is loaded, but the tape is not moving. This condition can mean that no application is communicating with the controller, or that the application is communicating but is not delivering commands for tape motion.
2.	The yellow TAPE IN USE indicator blinks irregularly.	A read or write is in progress.
3.	The yellow TAPE IN USE indicator blinks regularly.	The tape is loading, unloading, or rewinding.
4.	The audio transducer beeps and the green OPERATE HANDLE indicator turns on.	The tape is unloaded.
5.	All four right-side indicators blink	An error has occurred during operation.

3.5.6 Unloading A Cartridge

NOTE

The following procedure presumes that the operator manually initiates the unloading sequence by pressing the Unload push-button. In some host-driven applications, the application software may issue the appropriate system software command to initiate the unloading sequence, producing the same effect.

1. Press the UNLOAD push-button on the front panel's right side (or issue the appropriate system software command). The yellow TAPE IN USE indicator blinks as the tape rewinds.
2. When the internal audio transducer beeps and the green Operate Handle indicator lights steadily, pull the cartridge insert/release handle open by pulling the bottom edge up and forward. (Refer to Figure 3-4).
3. Remove the cartridge by pulling it forward from the aperture.
4. Push the insert/release handle closed by pushing front edge back and down.

Figure 3-4 Unloading Cartridge From Tape Drive

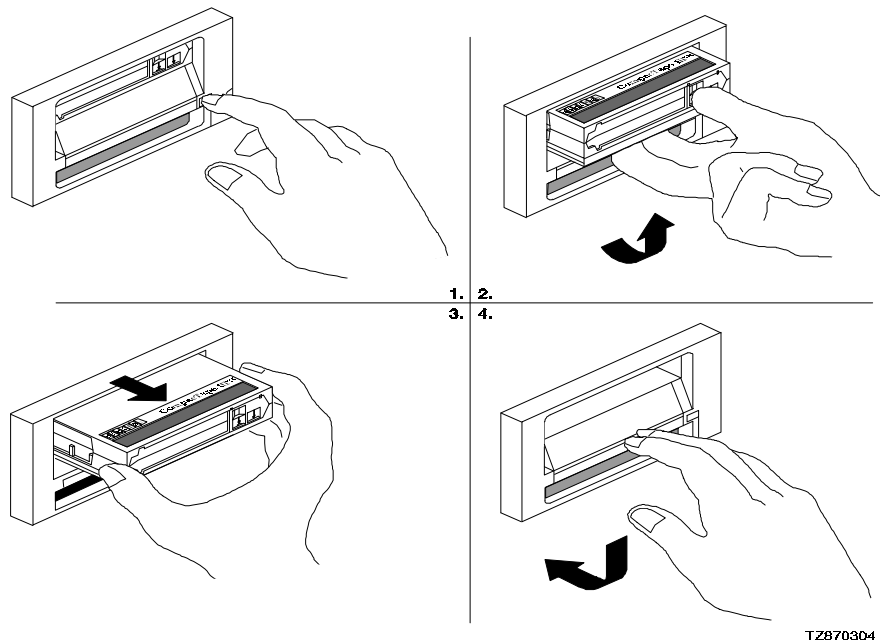

3.5.7 Using the Tape Cleaning Cartridge

Table 3–7 explains when you should use the cleaning cartridge.

NOTE

The cleaning cartridge expires after approximately 20 uses, after which time there is insufficient cleaning area remaining on the cleaning tape to adequately clean the heads.

Table 3–7 When To Use the Cleaning Cartridge

	If ...	It means ...	And you should ...
1.	The yellow USE CLEANING TAPE indicator lights.	The drive heads need cleaning or the tape is defective (see Item 3, in this table).	Use the cleaning cartridge. Follow the instructions in Section 3.5.6 for unloading the data cartridge, then follow the instructions in Section 3.5.4 to load the CompacTape III Cleaning tape into the drive. The cleaning operation begins automatically as soon as the cartridge insert/release handle becomes closed. When cleaning is complete, the internal beeper sounds to tell you to remove the cleaning cartridge.
2.	A particular cartridge causes the USE CLEANING TAPE indicator to turn on frequently.	The data cartridge may be defective.	Back up this data on another cartridge, and then discard the old cartridge. A damaged cartridge may cause unnecessary use of the cleaning cartridge.
3.	The USE CLEANING TAPE indicator turns on after you clean the drive heads and reload your data cartridge.	Your data cartridge may be causing the problem.	Try a different data cartridge.
4.	The USE CLEANING TAPE indicator is on after you load the cleaning cartridge.	Cleaning has not been done and the cleaning cartridge has expired.	Discard and replace the cleaning cartridge.

CAUTIONS

Remove a cartridge from the tape drive before turning off or powering down the host system. Failure to remove a cartridge can result in damage to the cartridge and/or to the tape drive.

To prolong the life of a cartridge, return the cartridge to its plastic case and secure the case cover when you remove the cartridge from the tape drive.

3.5.8 Preserving Cartridges

To maximize the life of recorded or unrecorded cartridges, store cartridges in a clean environment with the following conditions:

- Do not drop or bang the cartridge. Doing so can displace the tape leader, making the cartridge unusable and possibly damaging the drive.
- Keep tape cartridges out of direct sunlight and away from heaters and other heat sources.
- Store tape cartridges in temperatures between 10°C and 40° C (50°F to 104°F). For longer cartridge life, always store the cartridge in its plastic container and in room environment conditions of 72°F ± 7°F (22°C ± 4°C).
- If the tape cartridge has been exposed to heat or cold extremes, stabilize the cartridge at room temperature for the same amount of time it was exposed—up to 24 hours.
- Do not place cartridges near electromagnetic interference sources, such as terminal, motors, video, or X-ray equipment. (Data stored on the tape can be altered by the electromagnetic interference created by such sources.)
- Store tape cartridges in a dust-free environment where the relative humidity is between 20% and 80%. For longer cartridge life, store the cartridge at 40% ± 20% relative humidity.
- Place an identification label only in the slide-in slot on the front of the cartridge; do not affix any adhesive label to the surface of the cartridge.
- Do not adhere labels to the cartridge anywhere except in the slide-in slot.

CAUTION

If you reuse a tape on which other data was previously recorded, and write from the beginning of the tape (BOT), all previously recorded data is lost, including density changes.

3.6 Density Selection Rules

Density selection occurs in accordance with the following rules:

READ/WRITE APPEND

If the tape currently mounted in the drive was recorded with a TK85 format, its read density will be determined by that existing format, and appended data will be in that same format.

WRITE From BOT

The density selected may occur through programmable host commands from the application software. If no specific host commands exist, however, the selected density will be the default, native TZ86 mode.

CAUTION

Regardless of the operating conditions, a write from BOT destroys existing data on the tape.

Maintenance

This chapter describes preventive maintenance and troubleshooting for the 6.0-GB DLT Cartridge Tape Drive. It identifies common errors, describes how to clean the heads of the tape drive, and provides a troubleshooting table to help diagnose common problems.

4.1 Introduction

This chapter describes what to do if you have problems with your tape drive or tape.

4.2 Common Errors

4.2.1 Avoiding Basic Problems

You can avoid some errors by following these basic guidelines:

- Use the correct cartridge type, as delineated in Chapter 1. (Any substitute media must comply with ANSI X3B5 certification requirements.)
- Care for your cartridges (both data and cleaning) in accordance with the guidelines in Chapter 3.
- Make sure the cartridge leader and the drive leader are in their correct positions. (Refer to Section 4.4, following.)
- Unload the cartridge before powering down the tape drive.
- Do not load a cartridge until after the tape drive is initialized.

4.2.2 Error Influences

If an error occurs during tape drive operation, you may be able to correct the error yourself. Factors influencing errors include the following:

- Defective media.
- Dirty drive heads.
- Operator or user errors.
- Incorrect backup commands.

Use Table 4–1 to interpret error symptoms, determine their cause, and take corrective action.

Table 4–1 Possible Corrections for Common Error Situations

Symptom	Probable Cause	Possible Correction
Failure to mount or read/write with new or used cartridge.	Bad cartridge	Retry same operation with a different cartridge.
	Dirty drive head(s)	Use CleaningTape III head-cleaning cartridge (see Section 3.6.5).
Application software-generated initialize command fails with parity error.	Tape calibration failed.	Use CleaningTape III head cleaning cartridge, or else try a different data cartridge.
Green Operate Handle indicator stays lit and tape does not move; Yellow Tape in Use indicator is lit but does not blink.	Cartridge loading error.	Dismount the cartridge and inspect it for a mispositioned leader (see Section 4.4.1 in this chapter). If the drive leader is not in the correct location, call your reseller or Digital services.
		Inspect the drive for a damaged, misplaced, or unhooked leader (see Section 4.4.2 in this chapter). If the drive leader is not in the correct location, call your reseller or Digital services.
All indicators are blinking.	Drive failed self-test or detected a hard error during operation.	Try to clear the error by pressing the Unload button, or turn power off and then back on again. If the error does not clear (the tape does not rewind and unload, and the lights blink), you have a hardware failure; call your reseller or Digital services.

4.3 Cleaning the Heads

This section describes how to clean the heads of the tape drive. The heads are the components that physically read and write data to and from the cassette tape (media). We recommend that you perform the head-cleaning procedure approximately every two weeks, or after 50 hours of drive usage. Under normal conditions, it should not be necessary to exceed this cleaning schedule. If a particular cassette causes problems, try another data cassette.

CAUTION

Never attempt to clean the heads in a manner other than described in the following procedure. Doing so may void the product warranty.

To clean the heads, use the CleaningTape III head-cleaning cartridge, as follows:

1. Apply power to the tape drive and wait for the internal audio transducer to beep and the green OPERATE HANDLE indicator to light..

2. Pull open the cartridge insert/release handle and insert the yellow CleaningTape III head-cleaning cassette (Part No. TK85HC) into the drive for its full length, then close the handle (refer to Figure 3–3).
3. When you close the cassette insert/release handle after inserting the tape, the drive automatically executes the head-cleaning operation, which takes at least 30 seconds. When the head-cleaning cassette has completed this task, the tape drive electronics (1) stop the drive, (2) unlatch the cartridge insert/release handle, (3) sound the beeper, and (4) turn on the green OPERATE HANDLE indicator so that you can remove the head-cleaning cartridge.
4. Mark the frequency-of-use label on the head-cleaning cassette, placing a check mark in the next-available square on the card each time you use the head-cleaning cassette.

CAUTION

Remove the head-cleaning cassette as soon as possible following completion of the cleaning operation. Leaving a head-cleaning cassette in the drive might result in redundant cleaning operations each time power to the tape drive unit is turned off and on, resulting in unnecessary wear on the tape drive's read/write heads.

Under normal conditions, the head-cleaning cassette is effective for about 20 cleanings. If the head-cleaning cassette has been overused, so that it is expired, the Use Cleaning Tape will remain lit after you load the cleaning cassette, and no cleaning action will take place. If this happens, try another cleaning tape.

4.4 Inspections

4.4.1 Checking the Cartridge Leader

CAUTIONS

Do not touch exposed magnetic tape inside your tape cartridge; the normal oil on your skin can damage the tape and cause subsequent problems with respect to writing new data or reading data already stored.

If the tape leader inside the cartridge is not in the correct position, do not try to fix it. Instead, discard that cartridge and substitute a different cartridge.

Before you use a tape cartridge, be sure its tape leader is in the correct position, as illustrated in Figure 4–1. Lift the door latch with your thumb and open the small door on the rear face of the cartridge to expose the leader.

4.4.2 Checking the Drive Leader

To examine the drive take-up leader, tilt the cartridge receiver door on the front of the drive and look inside to see that the drive leader is connected to the buckling link-hook, which should be engaged in the leader slot as illustrated in Figure 4–2 and Figure 4–3.

Figure 4-1 Checking Out Cartridge Leader

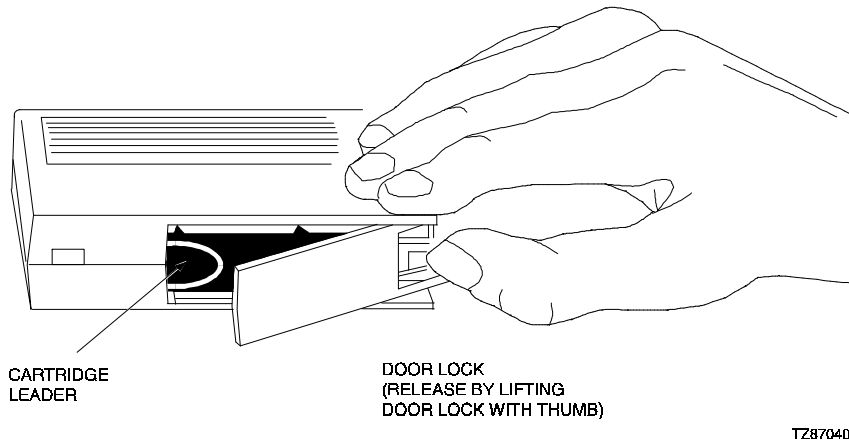

Figure 4-2 Correct Engagement of Take-Up Leader in Tape Drive

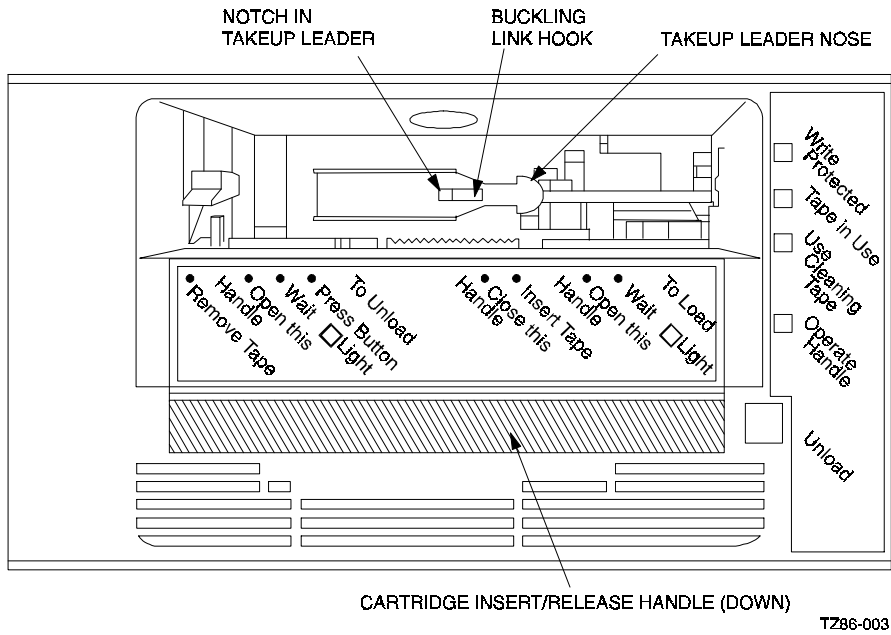
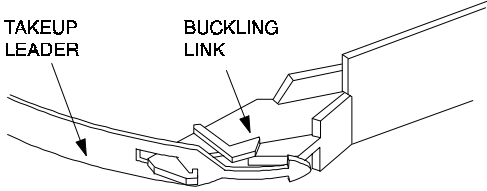

Figure 4-3 Correct and Incorrect Positions of Tape Drive Leader

ACCEPTABLE



**CORRECT
LOCATION
OF TAKEUP
LEADER NOSE
IN FRONT
OF LINK**

NOT ACCEPTABLE

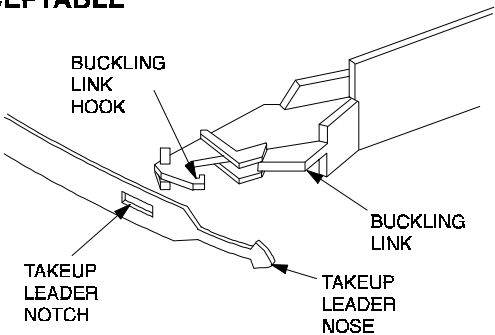

**LEADER
UNHOOKED**

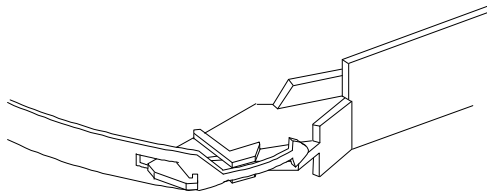

**TAKEUP
LEADER NOSE
DISPLACED
ABOVE
LINK**

TZ870403

Troubleshooting

Table 4–2 describes some common drive problems and suggests possible solutions.

Table 4–2 Troubleshooting Table

Symptom	Probable Cause	Possible Solution
Unable to back up or copy data to tape.	Cartridge write-protected. No tape in drive.	1. Set write-protected tab on cartridge to write-enabled. 2. Insert tape.
WRITE PROTECTED indicator flashes orange.	Excessive tape errors.	Perform head cleaning procedure (Section 3.5.7) . If error repeats, try another tape.
TAPE IN USE and WRITE PROTECTED LEDs flash rapidly in unison.	Dirty heads or bad media. Drive error, possibly a hard failure.	Eject tape. Perform head cleaning procedure (Section 3.5.7) . If error repeats, try another tape. Eject tape. Power off and power on the drive. If error repeats, replace the drive.
After applying power, nothing happens. All indicators off, except green OPERATE HANDLE indicator.	No tape loaded.	Load tape.
Drive not available to system.	Drive not plugged in. (If SBB unit, Storage Expansion Pedestal may not be plugged in.) SCSI ID switches set to incorrect address. Defective SCSI cable.	1. Check ac power source. 2. Check SCSI ID switch settings. 3. Ensure power cable is plugged in and SCSI cable is seated properly.



Specifications

This appendix describes the physical, electrical, and environmental specifications for the SWXTL-AA 6.0-GB DLT Cartridge Tape Drive.

Table A–1 6.0-GB DLT Cartridge Tape Drive Specifications

Characteristic	Specification(s)
Performance	
Read/write speed	100 in/s, streaming
Sustained SCSI data rate (maximum)	800 KB/s
Synchronous SCSI data transfer (burst rate)	4 – 5 MB/s
Sustained transfer rate, formatted data	Up to 2.5 MB/s
Hard error rate (detected)	1 in 10^{17} bits read (worst case)
Error rate (undetected)	1 in 10^{30} bits read (worst case, calculated)
Error correction code	Custom Reed-Solomon ECC
Drive interface	SCSI-2
Passes per cassette tape	Over 500,000 passes
Power requirements	40 watts (maximum)
Data organization	
Recording format	112-track serial serpentine fixed block
Recording density	42,500 bits/in
Track density	224 tracks/in
Record size	1 to 256 KB with 4-KB blocking factor
Maximum capacity (formatted)	6.0 GB per cartridge (assuming 2:1 compression ratio)

(Continued on next page)

Table A-1 6.0-GB DLT Cartridge Tape Drive Specifications (Continued)

Characteristic	Specification(s)
Recording medium:	
Tape	0.5 metal particle (MP) tape, 1400 to 1500 Oersted, 0.5 mil thick
Length	1186 ft (usable)
Cartridge	CompacTape III 0.5-in tape in a 4.1x4.1x1 in cartridge
Durability	500,000 tape-head passes
Shelf life	10 years minimum @20°C and 40% RH (noncondensing)

Operating environment:	
Temperature	10°C to 40°C
Relative humidity	20% to 80% noncondensing
Altitude (maximum)	8,000 ft

Physical Characteristics

SWXTL-BA SBB Tape Drive	
Height	14.52 cm (5.72 in)
Width	23.49 cm (9.25 in)
Length	33.22 cm (13.08 in)
Weight	3.4 Kg (7.55 lb)

B

Product Notes for Novell[™] and MS-DOS[™]

This appendix provides information for the system administrator, who should read this appendix before installing and using the 6.0-GB DLT Cartridge Tape Drive with a host system operating under the Novell, MS-DOS, or MS-DOS/WINDOWS operating systems.

B.1 Host SCSI Interface

The SWXTL-AA 6.0-GB DLT Cartridge Tape Drive device use the standard SCSI-2 command set to interface to the PC-based host system. Therefore, the host system must be equipped with a SCSI adapter to properly interface the tape drive with the host. For example, the host SCSI adapter might interface the computer's EISA bus to the SCSI-2 port of the tape drive.

A host PC SCSI adapter is normally supplied with a compatible software driver for use with its operating system. When operating under the Novell and MS-DOS or under the MS-DOS/WINDOWS operating systems, the software driver must be preloaded in accordance with the SCSI adapter manufacturer's installation procedure in order to ensure a proper interface between the 6.0-GB DLT Cartridge Tape Drive and the host. In addition, a user-level tape read/write software program may be required to implement tape support under the Novell, MS-DOS, or MS-DOS/WINDOWS environments. There are many commercial software products available that provide host or network-based functionality (data backup and restore, archiving, data logging, etc.) for these operating systems.

Before purchasing a user-level software product, ensure that the 6.0-GB DLT Cartridge Tape Drive is supported by that product (see note below). Commercial software vendors usually publish a supported hardware list, or have telephone technical support personnel that will answer questions regarding compatibility of a particular tape drive or other storage devices. When choosing a software product suitable for your application, follow the software vendor's installation procedure to implement support for your tape drive.

NOTE

The 6.0-GB DLT Cartridge Tape Drive is functionally equivalent to the TZ86 (DEC part no.) tape drive. Commercial software products that support the TZ86 will also support the SWXTL-AA SBB device.

Finally, if your host is operating under Novell Netware[™], Novell, Inc. provides a software product called "Server Backup" with some of its operating system products. This program

has been found to work well with the SWXTL-AA Tape Drive SBB. (The TZ867 mini-library autoloader is not supported by this software product, however.)



Density Selection with the SWXTL-AA DLT Tape Drive

This appendix provides information for the system administrator, providing information pertaining to switching of the SWXTL-AA drive between two density states (applicable only to application software capable of supporting both states).

C.1 Density Selection

Some application software supports both TZ85 and TZ86-series DLT tape drives and can switch the SWXTL-AA between the two density states. This switching is accomplished by addressing a FORCEDENSITY parameter, which has three states:

0 = automatic, as selected by the host.

1 = low density (TK85), regardless of hose selection.

2 = high density (TK86), regardless of host selection.

Consult your application software documentation for applicable information.

The SWXTL-AA drive defaults to TK86 format (high density) for all writes from BOT (Beginning of Tape). When you append data to the tape cartridge, the “current” media density (meaning whichever density was used for the data already on that tape cartridge) is used. To write in TK85 format, therefore, you can load a tape written in TK85 format and do an APPEND operation.

C.2 Density Selection Rules

Density selection occurs in accordance with the following rules:

READ/WRITE APPEND

If the tape currently mounted in the drive was recorded with a TK85 format, its read density will be determined by that existing format, and appended data will be in TK85 format. If the tape currently mounted in the drive was recorded with a TK86 format, similarly, its read density will be determined by that existing format, and appended data will be in TK86 format.

WRITE From BOT

The density to be used for a Write from BOT can be selected by programmable host commands from the application software, if that software has the capability of both formats. If no specific host commands exist, however, the selected density will be the default, native TZ86 mode.

CAUTION

Regardless of the operating conditions, a write from BOT destroys existing data on the tape.

Table C–1 delineates compatibility for cartridges you can use with the SWXTL-AA drive.

Table C–1 Cartridge Compatibility with the SWXTL-AA Tape Drive

Cartridge Type	Read/Write Ability on SWXTL-AA Tape Drive
CompacTape III (TK85)	Read/write in 85 Mode (48 tracks, 2.6 GBF)
CompacTape III (TK86)	Read/write in 86 Mode (112 tracks, 6.0 GBF)
CompacTape III (Blank)	Read/write in 86 Mode (112 tracks, 6.0 GBF)

A

ANSI X3B5 interchange format, 3-5, 4-1
Application software, 3-10
Avoiding problems, 4-1

B

Bad cartridge, 4-2
Bezel (SBB)
 removal of, 2-4

C

Cartridge
 how to load, 3-8, 3-9
 how to unload, 3-10
Cartridge compatibility, C-2
Cartridge insert/release handle, 3-13
Cartridge labels, 1-2
Cartridge loading error, 4-2
Checking cartridge leader, 4-3, 4-4
Cleaning cartridge
 expiration, 3-11
 when to use, 3-11
Cleaning tape, 1-4
Cleaning tape expiration, 1-4
Cleaning tape expiration label, 1-4
 use of, 1-4
CleaningTape III cartridge
 description, 1-4
Cleaning the heads, 4-2
Common drive problems, 4-6
CompacTape III cartridge, 1-2
 data tape (illus.), 1-3, 3-4
 cleaning tape (illus.), 1-4
 use and handling, 3-4
Configuration rules (SBB), 2-2, 2-3
Controls (front-panel), 3-3
Corrections for common errors, 4-2

D

Data protection, 3-7
Default density, C-1
Density selection rules, C-1
Density switching, 1-1
Design features, 1-1
Dirty drive head(s), 4-2
Drive take-up leader
 checking, 4-3

E

Electromagnetic field (SBB)
 precautions, 2-2, 2-3
Error correction, 4-2
Error sources, 4-1
Expiration label
 use of, 1-4
Expiration of cleaning cartridge, 3-11
Expiration of cleaning tape, 1-4

F

Failure of self-test, 4-2
FORCEDENSITY parameter, C-1
Front bezel
 removal of, 2-4
Front panel (illus.), 1-2
Front-panel controls and indicators, 3-1, 3-3
Front-panel indicators
 status indication, 3-4

H

Host SCSI Interface, B-1

I

Indicator

- OPERATE HANDLE, 3-3
- Tape in Use, 3-3
- Use Cleaning Tape, 3-3
- Write Protected, 3-3

Inspections, 4-3

Installation, 2-1, 2-3

- SWXTL-AA SBB in pedestal, 2-3

Interface with host, B-1

Introduction, 1-1

L

Loading a cartridge, 3-8

Loading cartridge into tape drive (figure), 3-9

M

Maintenance, 4-1

O

OPERATE HANDLE indicator, 3-3

Operating under Novell Netware, B-1

Operation, 2-1

O (Continued)

Operator's reference card, 2-1

Ordering replacement cartridges, 1-5

P

Pedestal, 2-1

Pedestal mounting restrictions, 2-4

Performance considerations, 1-1

POST (power-on self-test), 2-1, 2-4, 3-2

POST failure, 4-2

Power On Self Test (POST), 2-1, 2-4, 3-2

Preinstallation

- SBB, 2-2, 2-7

Preservation of cartridges, 3-12

Preventive maintenance, 4-1

Product overview, 1-1

Protecting data, 1-3, 3-7

Push-button

- UNLOAD, 3-2, 3-3

R

Reading data, 1-3

Removal of front bezel, 2-4

Right-side front panel indicators blinking (all), 3-3

S

SBB

- SCSI ID switch settings, 2-3

SCSI adapter on host, B-1

SCSI controller module, 1-1

SCSI-2 command set, B-1

SCSI ID address

- normal "automatic" setting, 2-2

SCSI ID switch settings, 2-3

- (location figure), 2-2

SCSI Interface

- under Novell, B-MS-DOS, B-and MS-

- DOS/Windows, B-1

- with Host, B-1

Selecting density, C-1

Server Backup program

- (Novell), B-1

Setting SCSI ID address, 2-2, 2-7

Slots (SBB)

- applicable limitations, 2-2, 2-3

- number of (3), 2-1

Specifications, A-1, A-2

SWXTL-AA SBB

- installation, 2-3

- setting SCSI ID address, 2-2

SWXTL-AA SBB Tape Drive, 2-1

T

Tape calibration failure, 4-2

Tape cartridges, 1-2, 1-5

- loading, 3-8

- loading (figure), 3-9

- ordering replacements, 1-5

- preservation of, 3-12

- prolonging life of, 3-11

- unloading (figure), 3-10

Tape drive leader

- correct position, 4-5

Tape drive specifications, A-1, A-2

tape drive status, 3-6

TAPE IN USE indicator, 3-3

Tape leader

- checking, 4-3

Troubleshooting, 4-1, 4-6

U

UNLOAD push-button, 3-2, 3-3

Unloading a cartridge, 3-10
(figure), 3-10

Unpacking

SBB, 2-1, 2-7

USE CLEANING TAPE indicator, 3-3

Use of cleaning tape expiration label, 1-4

User-level read/write software, B-1

W

WRITE PROTECTED indicator, 3-3

Write-protect slide switch, 1-2, 3-6

use of, 1-3

moving during read/write operation, 3-8

moving before tape drive operation, 3-7

Writing data, 1-3

Reader's Comments

Manual Order Number:

EK-SM1TD-UG. A01

SWXTL-AA 6.0-GB DLT Cartridge Tape Drive

Digital is committed to providing the best possible products and services. Since our manuals are important components of our products, we value your comments, corrections, and suggestions for improvements. Please take a few minutes to fill out and return this form, attaching additional sheets, if needed. Thank you.

Manual Rating	Excellent	Good	Fair	Poor
Accuracy (correct presentation of facts)	[]	[]	[]	[]
Completeness (adequate information)	[]	[]	[]	[]
Clarity (easy to understand)	[]	[]	[]	[]
Organization (logical sequence of information)	[]	[]	[]	[]
Layout (easy to follow subject matter)	[]	[]	[]	[]
Indexing (easy to locate desired information)	[]	[]	[]	[]

Errors Noted (please include page, paragraph, table or figure number)

Most-Liked Features

Least-Liked Features

Suggestions for Improvement

Return Address: Digital Equipment Corporation Customer Research Response Center ATTN: Nan Andrews Amish 334 South Street, SHR3-2/S27 Shrewsbury, MA 01545	_____
	Name _____ Phone _____

	Title _____

	Company _____

	Street Address _____

	Mail Stop _____

	City _____ State _____ ZIP _____

	Country (if other than USA) _____

digital™

Printed in U.S.A.