

**ILLUSTRATED
PARTS
BREAKDOWN**

**PrintServer 32
SYSTEM**

ILLUSTRATED PARTS BREAKDOWN (IPB)

The IPB is used to identify a part and its location in a hardware product. The document references specific item numbers in the associated parts list.

HOW TO USE THE IPB

1. Locate the figure containing the item of interest.
2. Locate the number (callout) of the item of interest.
3. Locate that item number in the associated parts list.

FORMAT

Each IPB is generally organized based on its first figure. All other assemblies and subassemblies are referenced from this figure. Each figure contains numeric callouts of all major parts (items).

PARTS LIST

Each parts list contains the following:

Figure and Item No. – Lists the figure number and its referenced numeric callout

Description – Presents the name and a brief description of the item. A single asterisk (*) preceding the description denotes item is a

subassembly to its referenced figure. A double asterisk (**) preceding the description indicates that this item is subordinate to the preceding single asterisk item.

DEC Part No. – Lists the Digital/Vendor part number. The letter in the column heading indicates the current revision level of the Engineering Drawing for the referenced figure.

ECO Cut-In – Lists the top assembly drawing number and revision level at first printing. All additional revisions to an item are listed in this column.

Used On Code – Lists letters referring to the product variation assigned in Figure 1. When this column is blank, the item is used in all variations.

Ref Fig No. – Lists a cross reference between figures within the IPB.

PART NUMBER/PART DESCRIPTION INDEX SECTION

Lists items by part number numerically, and description alphabetically. Items are also referenced to a location within the IPB by figure and item number.

ECO/REVISION HISTORY

**OTHER IPB
MANUALS
REFERENCED**

FIGURE NO.	ASSEMBLY	INITIAL LEVEL	CURRENT LEVEL	PRINTING DATE	OTHER IPB MANUALS REFERENCED
1	LPS32	00000	DSG001	25-APR-93 2nd Printing	

Digital Equipment Corporation reserves the right, without notice, to make substitutions and modifications in the specifications of products documented in this manual and further reserves the right to withdraw any of these products from the market without notice.

Digital Equipment Corporation is not responsible for errors which may appear in the technical description (including illustrations and photographs) of the products covered by this manual.

None of the descriptions contained in this manual imply the granting of any license whatsoever to make, use or sell equipment constructed in accordance therewith.

Restricted Rights: Use, duplication or disclosure by the U.S. Government is subject to restrictions as set forth in subparagraph (c) (1) (ii) of the Rights in Technical Data and Computer Software clause at DFARS 252.227-2713.

Copyright © 1992,1993 by Digital Equipment Corporation. All rights reserved.
Printed in U.S.A.

The postage –paid READER'S COMMENTS form on the last page of this document requests your critical evaluation to assist us in preparing future documentation.

The following are trademarks of Digital Equipment Corporation :

DECdirect, PrintServer and the DIGITAL logo.

All other trademarks and registered trademarks are the property of their respective holders.

TABLE OF CONTENTS

FIGURE NUMBER	TITLE	PAGE NUMBER
1	PrintServer 32 SYSTEM	1
2	MAIN UNIT COMPONENTS, LPS32	5
3	TABLE UNIT COMPONENTS, LPS32	7
4	EXTERIOR, LPS32	9
5	PCB RACK ASSEMBLY	11
6	ELECTRICAL ASSEMBLY	13
7	DRIVE ASSEMBLY, MAIN	15
8	OPTICAL ASSEMBLY	17
9	FEED ASSEMBLY, PAPER (CASSETTE)	19
10	GATE ASSEMBLY, PAPER FORK	21
11	FUSING ASSEMBLY	23
12	LCOT UNIT COMPONENTS – SECTION 1 (LARGE CAPACITY OUTPUT TRAY)	25
12A	LCOT UNIT COMPONENTS – SECTION 2 (LARGE CAPACITY OUTPUT TRAY)	27
12B	LCOT UNIT COMPONENTS – SECTION 3 (LARGE CAPACITY OUTPUT TRAY)	29
13	DPX (DUPLEXER) ASSEMBLY	31
14	LCIT, (LARGE CAPACITY INPUT TRAY)	33
15	FEED ASSEMBLY, PAPER (LCIT)	35
16	FEED ASSEMBLY, TABLE	37
17	HARNESS LAYOUT – REAR VIEW	39
18	HARNESS LAYOUT – TABLE	41
19	HARNESS LAYOUT – (LCIT)	43
20	HARNESS LAYOUT – (LCOT)	45
21	CONSUMABLES	47
22	SERVICE PM KITS	49
	PART NUMBER INDEX	A-1
	PART DESCRIPTION INDEX	B-1

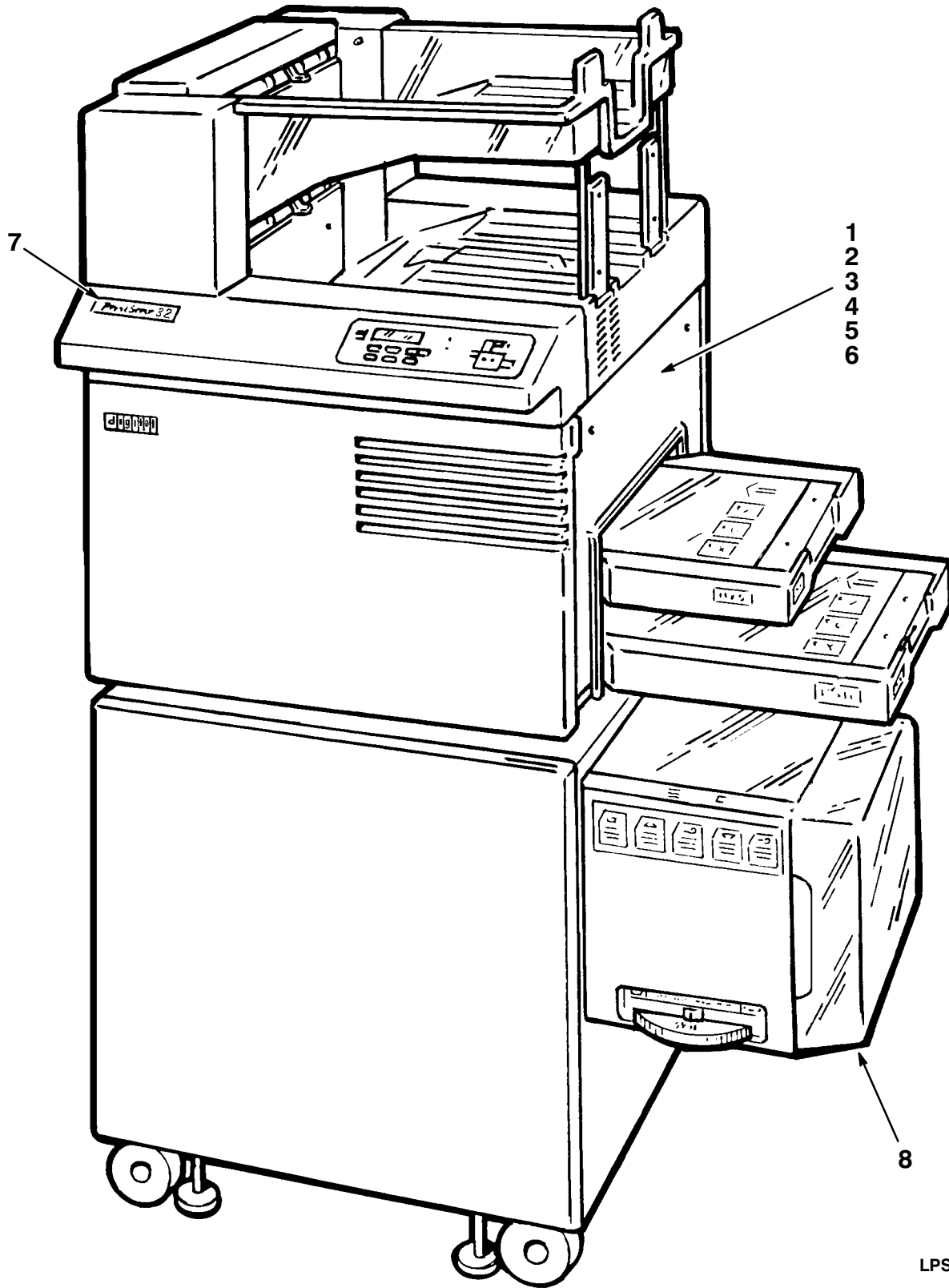

LPS32-01-SC

Figure 1. PrintServer 32 System

FIG. & ITEM NO.	DESCRIPTION	DEC PART NO. ^c	ECO CUT-IN LPS32 00000	USED ON CODE	REF FIG NO.
1-	PrintServer 32 System				
	Code A – Used on LPS32–A2 (Simplex) (120V)	LPS32–A2		A	
	Code B – Used on LPS32–A3 (Simplex) (240V)	LPS32–A3		B	
	Code C – Used on LPS32–B2 (Duplex) (120V)	LPS32–B2		C	
	Code D – Used on LPS32–B3 (Duplex) (240V)	LPS32–B3		D	
	Code E – Used on LPS32–C7 (Simplex w/Mem) (120V)	LPS32–C7		E	
	Code F – Used on LPS32–C8 (Duplex w/Mem) (240V)	LPS32–C8		F	
	Code H – Used on LPS32–XA (Simplex) (120V)	LPS32–XA		H	
	Code J – Used on LPS32–XB (Simplex) (240V)	LPS32–XB		J	
	Code K – Used on LPS32–XC (Duplex) (120V)	LPS32–XC		K	
	Code L – Used on LPS32–XD (Duplex) (240V)	LPS32–XD		L	
1	*ENGINE, SIMPLEX (No Controller) (120V)	LPS32–XA		AE	
	**Engine, Print (100–120V)	30–39034–01			
	**Kit A, Shipaway	30–39034–07			
	**Kit B, Shipaway	30–39034–08			
2	*ENGINE, SIMPLEX (No Controller) (240V)	LPS32–XB		B	
	**Engine, Print (200–240V)	30–39034–02			
	**Kit A, Shipaway	30–39034–07			
	**Kit B, Shipaway (Europe)	30–39034–09			
3	*ENGINE, DUPLEX (No Controller) (120V)	LPS32–XC		CF	
	**Engine, Print (100–120V)	30–39034–03			
	**Kit A, Shipaway	30–39034–07			
	**Kit B, Shipaway	30–39034–08			
4	*ENGINE, DUPLEX (No Controller) (240V)	LPS32–XD		D	
	**Engine, Print (220–240V)	30–39034–04			
	**Kit A, Shipaway	30–39034–07			
	**Kit B, Shipaway (Europe)	30–39034–09			
5	*Module, TURBO Controller (Not Shown)	54–20830–03		A–F	
6	*Module, TURBO Memory Option (Not Shown)	54–20734–01		EF	
7	*Medallion, Front Panel (PrintServer 32)	74–36751–03		A–F	
8	*LCIT, (LARGE CAPACITY INPUT TRAY) includes 7 Trays (30–39034–05)	LPS3X–BA			14
	Miscellaneous Tools (Not Shown)				
	Vacuum Cleaner (200V)	29–26259–00			
	Vacuum Cleaner (100V)	29–25526–00			
	Bags, Filter (Vacuum Cleaner)	29–26017–00			
	Kit, Cleaning	29–26234–00			

FIG. & ITEM NO.	DESCRIPTION	DEC PART NO.	ECO CUT-IN LPS32 00000	USED ON CODE	REF FIG NO.
1-	PrintServer 32 System (Continued)				
	Cables / Labels (Not Shown)				
	*Cable Assembly (COAX Male-Female)	17-03218-01		A-F	
	*Label, Product Conversion (XA-A2)	36-30689-13		A	
	*Label, Product Conversion (XA-C7)	36-30689-14		E	
	*Label, Product Conversion (XC-B2)	36-30689-15		C	
	*Label, Product Conversion (XC-C8)	36-30689-16		F	
	*Label, Product Conversion (XB-A3)	36-30689-17		B	
	*Label, Product Conversion (XD-B3)	36-30689-18		D	
	*Label, Product Conversion (XB-A3)	36-30689-19		B	
	*Label, Product Conversion (XD-B3)	36-30689-20		D	
	*Label, Direct Thermal 1.62 x 6	36-28231-02		A-F	
	*Label, Serial Number VLC, Artwork	36-37522-02		A-F	
	Documentation (Not Shown)				
	*Documentation, PrintServer 32 Customer	EK-LPS32-DK		A-F	
	*Documentation, PrintServer 32 Service Guide	EK-LPS32-SG		A-F	
	*Video, PrintServer 32 User Maintenance	EK-PRNTR-VD		AC	
	*Card, Read Me First	EK-LPS32-FC		AC	
	Country Kits (Not Shown)				
	*KIT, COUNTRY (Belgium,France, Germ.,Holland)	LPS3K-AB		BD	
	**Cord, Power (250V)	17-00199-21			
	**Label, Jam Clearance (French)	36-38723-02			
	**Label, Jam Clearance (German)	36-38723-04			
	**Label, Jam Clearance (Dutch)	36-38723-05			
	**Label, LPS32 OCP (French)	36-37959-02			
	**Label, LPS32 OCP (German)	36-37959-03			
	**Label, LPS32 OCP (Dutch)	36-37959-04			
	**Documentation, Operator's Guide (Ger)	EK-LPSG2-OG			
	**Documentation, Operator's Guide (Dutch)	EK-LPSH2-OG			
	**Documentation, Operator's Guide (French)	EK-LPSP2-OG			
	**Label, Postcard FTZ	36-30422-07			
	*KIT, COUNTRY (Denmark)	LPS3K-AD		BD	
	**Cord, Power (250V)	17-00310-08			
	KIT, COUNTRY (UK/Ireland)	LPS3K-AE		BD	
	**Cord, Power (250V)	17-00209-15			
	KIT, COUNTRY (Finland,Norway, Portugal,Sweden)	LPS3K-AF		BD	
	**Cord, Power (250V)	17-00199-21			

FIG. & ITEM NO.	DESCRIPTION	DEC PART NO. ^c	ECO CUT-IN LPS32 00000	USED ON CODE	REF FIG NO.
1-	<p style="text-align: center;">Country Kits (Continued)</p> <p>*KIT, COUNTRY (Italian) **Cord, Power (250V) **Label, Jam Clearance (Italian) **Label, LPS32 OCP (Italian) **Documentation, Operator's Guide (Italian)</p> <p>*KIT, COUNTRY (Switzerland) **Cord, Power (250V) **Label, Jam Clearance (French) **Label, Jam Clearance (German) **Label, Jam Clearance (Italian) **Label, LPS32 OCP (French) **Label, LPS32 OCP (German) **Label, LPS32 OCP (Italian) **Documentation, Operator's Guide (German) **Documentation, Operator's Guide (Italian) **Documentation, Operator's Guide (French)</p> <p>*KIT, COUNTRY (Spain) **Cord, Power (250V) **Label, Jam Clearance (Spanish) **Label, LPS32 OCP (Spanish) **Documentation, Operator's Guide (Spanish)</p> <p>*KIT, COUNTRY (Israel) **Cord, Power (250V)</p> <p>KIT, COUNTRY (Australia/New Zealand) **Cord, Power (250V)</p>	<p>LPS3K-AI 17-00364-18 36-38723-06 36-37959-05 EK-LPSU2-OG</p> <p>LPS3K-AK 17-00210-13 36-38723-02 36-38723-04 36-38723-06 36-37959-02 36-37959-03 36-37959-05 EK-LPSG2-OG EK-LPSU2-OG EK-LPSP2-OG</p> <p>LPS3K-AS 17-00199-21 36-38723-03 36-37959-07 EK-LPSS2-OG</p> <p>LPS3K-AT 17-00457-16</p> <p>LPS3K-AZ 17-00198-14</p>		<p style="text-align: center;">BD</p> <p style="text-align: center;">BD</p> <p style="text-align: center;">BD</p> <p style="text-align: center;">BD</p> <p style="text-align: center;">BD</p>	

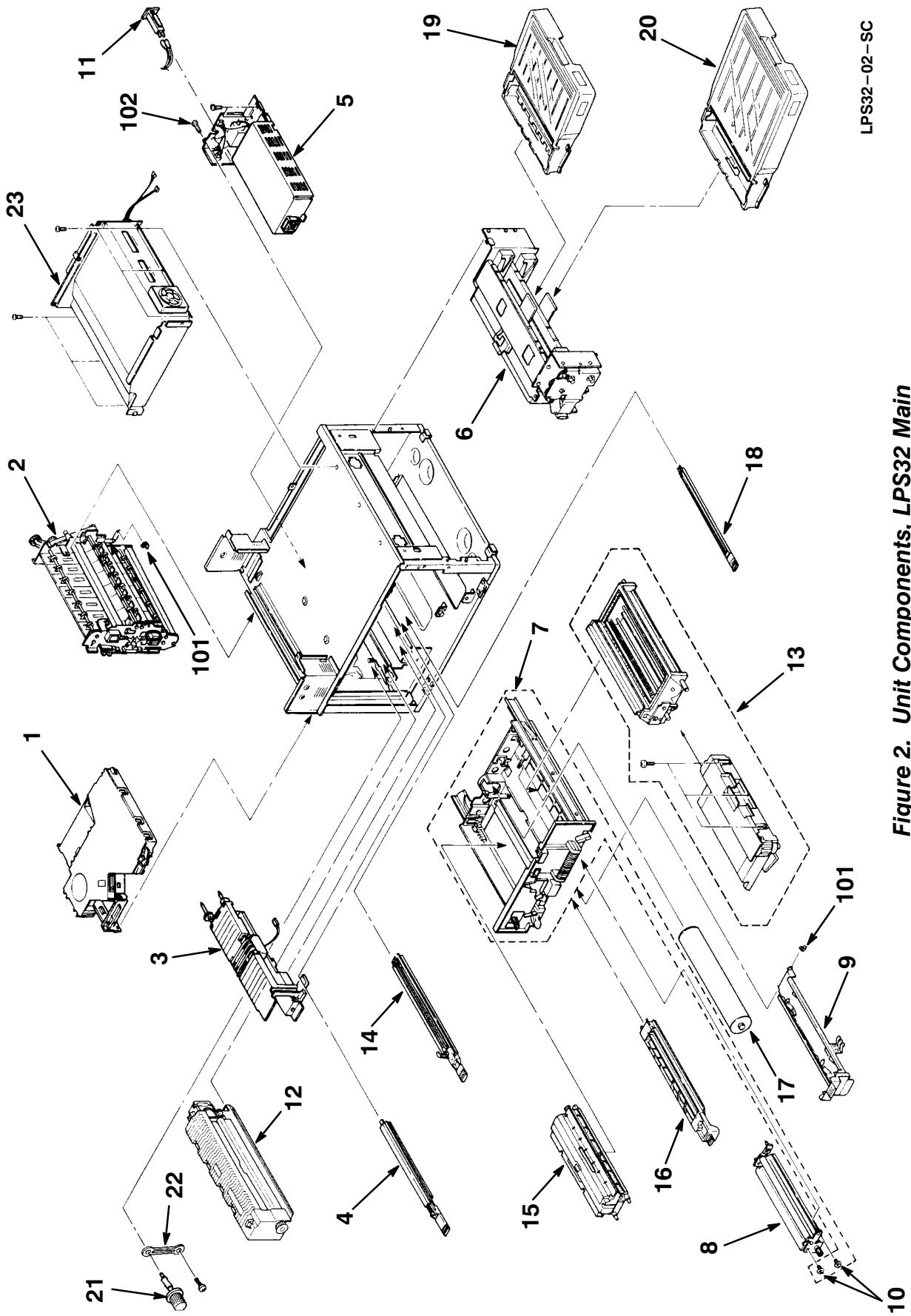

Figure 2. Unit Components, LPS32 Main

FIG.& ITEM NO.	DESCRIPTION	VENDOR PART NO.	DEC PART NO.	USED ON CODE	REF FIG NO.
2-	UNIT COMPONENTS, LPS32 MAIN		N/A		
1	*OPTICAL ASSEMBLY		29-29631-01		8
2	*GATE ASSEMBLY, PAPER FORK		29-29639-01		10
3	*Transport Unit		29-29643-01		
4	*Led Unit, Quenching		29-29648-01		
5	*Power Supply (100V)		29-29626-01		
	*Power Supply (200V)		29-29627-01		
6	*FEED ASSEMBLY, PAPER (CASSETTE)		29-29632-01		9
7	*Drawer Unit		29-30255-01		
8	*Roller, Registration		29-30253-01		
9	*Wire Assembly, T/S		29-30256-01		
10	*Cap Assembly, Registration		29-30257-01		
11	*Breaker, Circuit (W28XQ1A - 15, 15A)		29-29651-01		
	*Breaker, Circuit (W28XQ1A - 8, 8A)		29-29652-01		
12	*FUSING ASSEMBLY (110V)		29-29637-01		11,22
12	*FUSING ASSEMBLY (220V)		29-29638-01		11,22
13	*DEVELOPER UNIT		29-29635-01		22
14	*WIRE, MAIN AUTO		29-30258-01		21
15	*CLEANING UNIT		29-30254-01		21
16	*T/S CHARGE WIRE		29-30252-01		21
17	*Drum, OPC (See Note 1)		N/A		21
18	*Plate, Shield		29-30259-01		21
19	*Cassette, Paper : SCIT (Small)		LPS4X-BA		
20	*Cassette, Paper : SCIT (Large)		LPS4X-BB		
21	*Screw, Fusing Stopper Thumb	G0131447			
22	*Strap, Thumb Screw	G0131448			
23	*PCB RACK ASSEMBLY	N/A			5
101	*Ring, Snap	54472681			
102	*Screw, Phi Truss Hd M4 x 8	08011185			
	(Not Shown)				
	*KIT , 320K Service PM (110V) (See Note 2)		29-29655-01		22
	*KIT , 320K Service PM (220V) (See Note 2)		29-29656-01		22
	NOTE 1 : If OPC needs replacement before normal 100K maintenance, use the OPC Drum from the LPS20 OPC Drum Kit - LPS2X-AC or 29-27398-01.				
	NOTE 2 : See Figure 21 for Service Kit Info.				

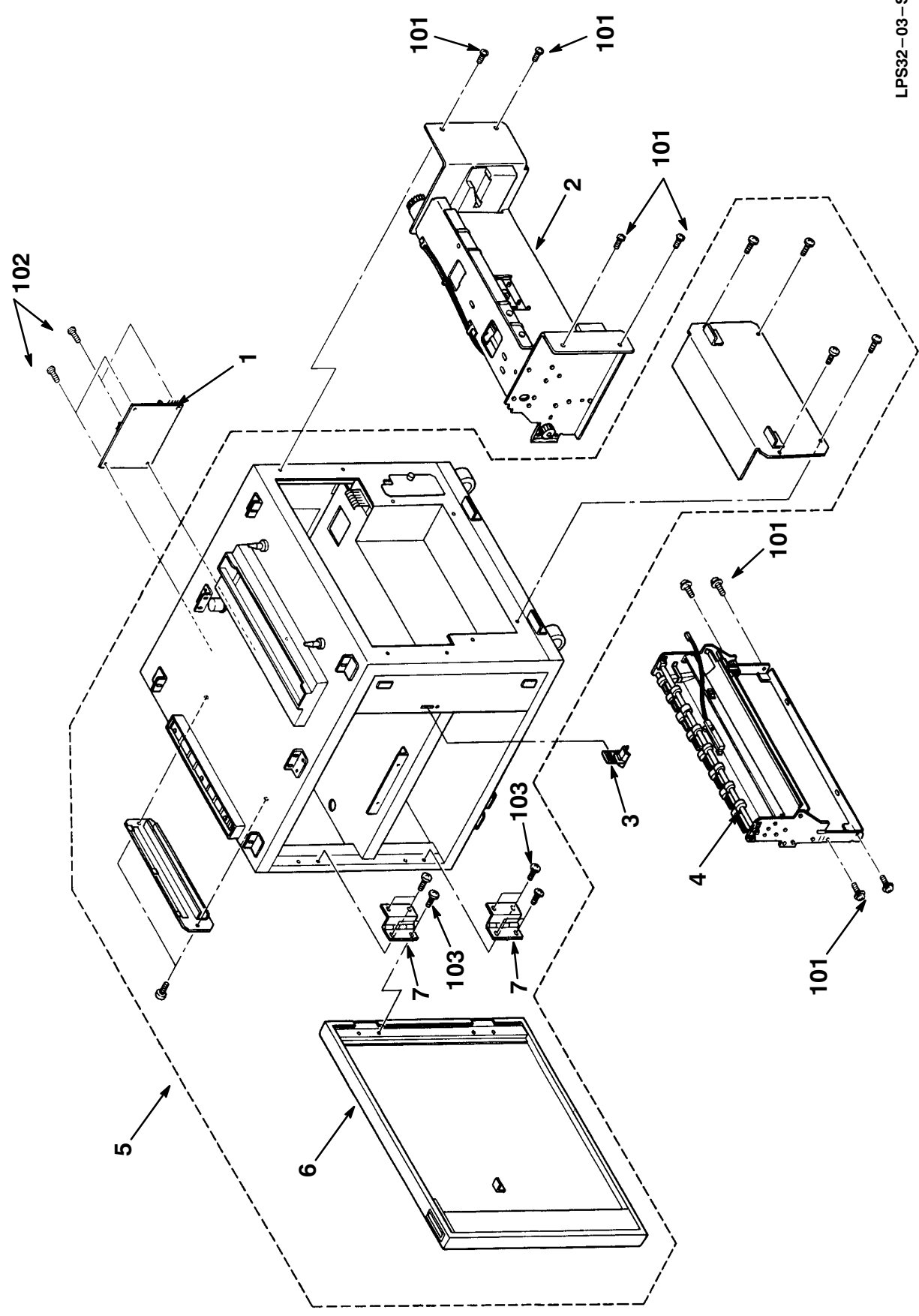

Figure 3. Table Unit Components, LPS32

FIG. & ITEM NO.	DESCRIPTION	VENDOR PART NO.	DEC PART NO.	USED ON CODE	REF FIG NO.
3-	TABLE UNIT COMPONENTS, LPS32		N/A		
1	*Module, Table Drive		29-29647-01		
2	*FEED ASSEMBLY, PAPER (LCIT)		29-29645-01		15
3	*Tool, T/S Charger		29-30524-01		
4	*FEED ASSEMBLY, TABLE		29-27358-01		16
5	*Table Assembly, LPS32 w/Door (Empty)		N/A		
6	*Door Assembly, Table		29-30262-01		
7	*Hinge, Table Door		29-30263-01		
101	*Screw, Phi Pan Hd M4 x 6	03140060B			
102	*Screw, Phi Hd w/Washer M3 x 6	09513006B			
103	*Screw, Phi Truss Hd M4 x 6	03440060F			
	NOTE: DPX is included in this Table Unit for Duplexer Models. See Figure 13.				

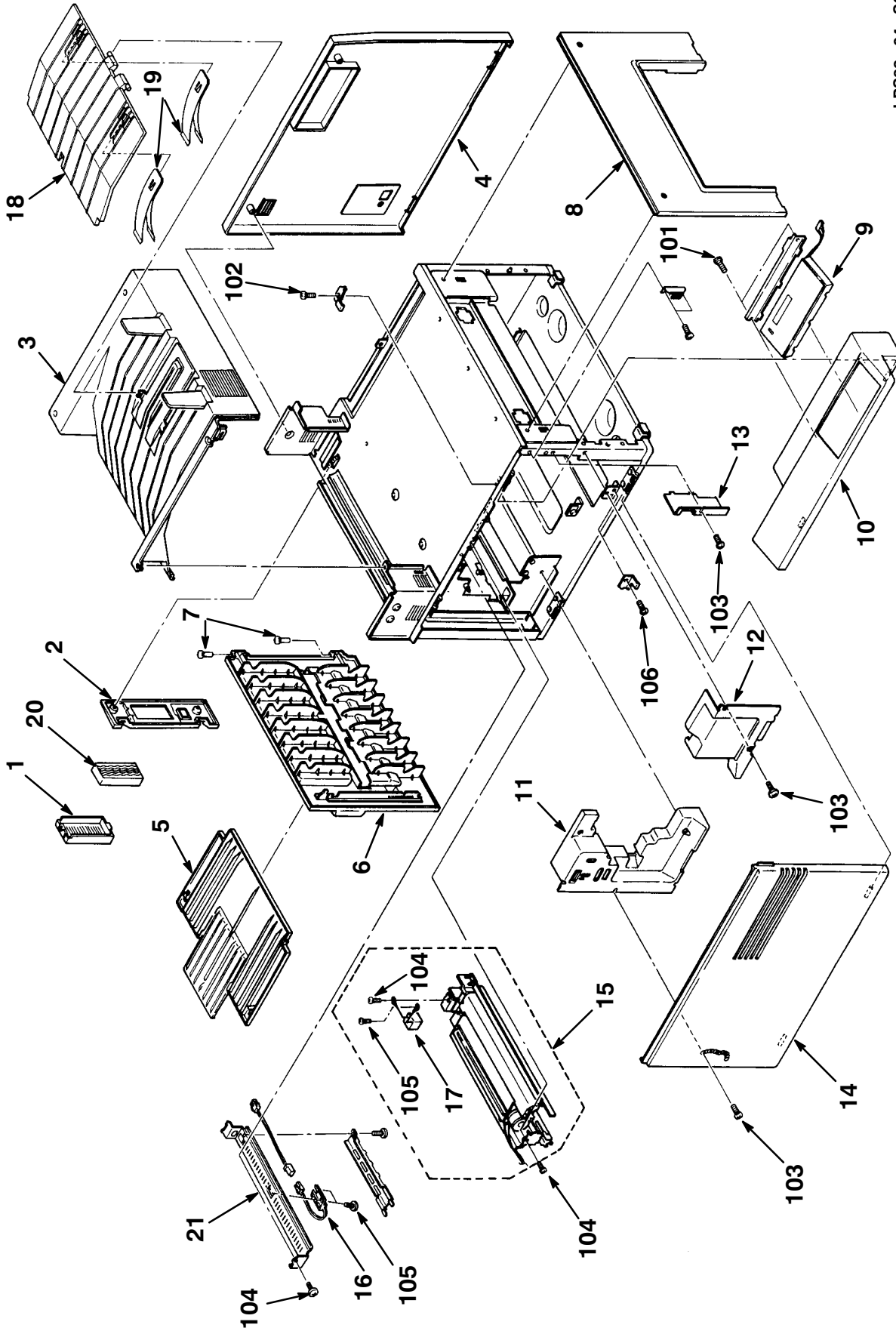
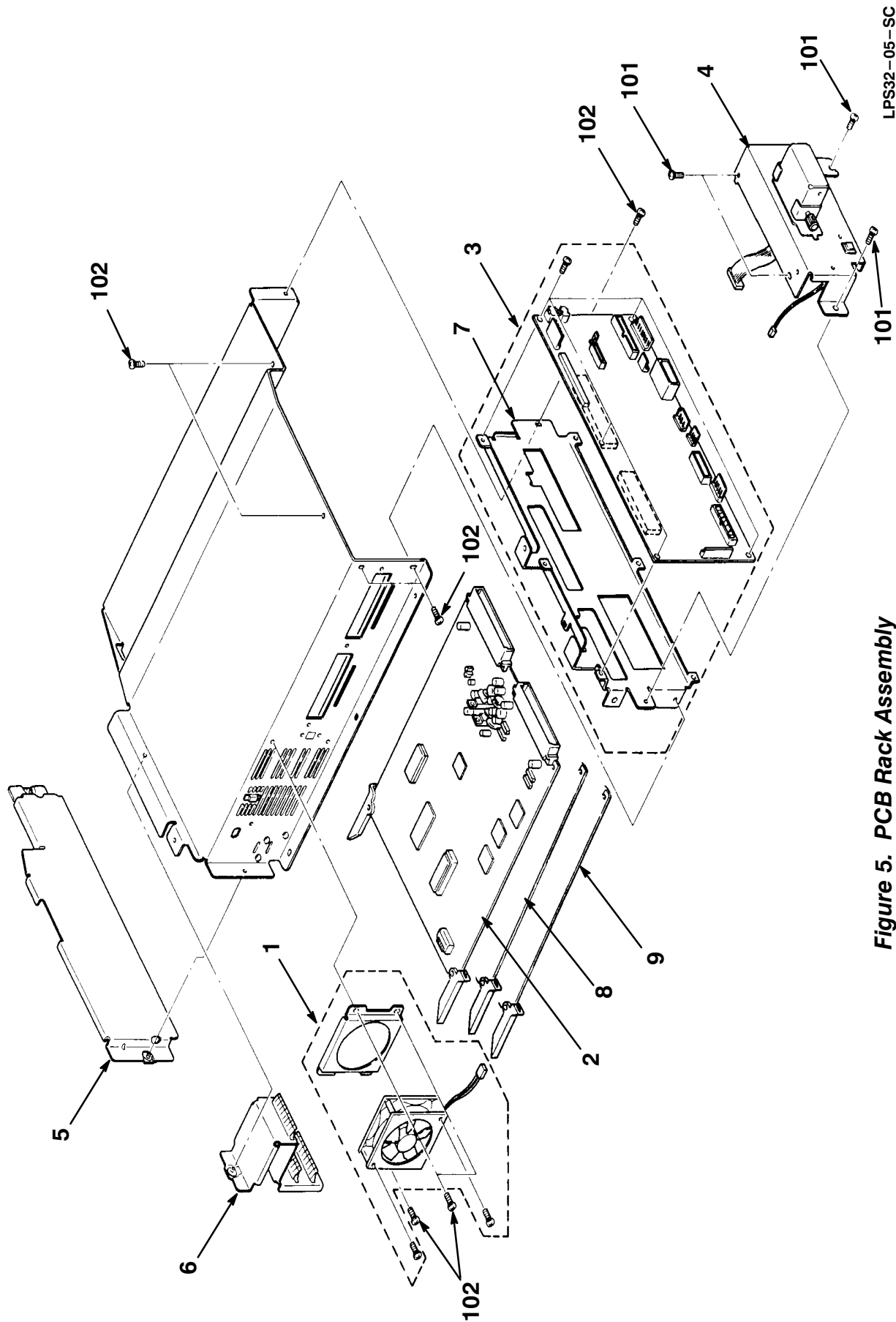

Figure 4. Exterior, LPS32

FIG.& ITEM NO.	DESCRIPTION	VENDOR PART NO.	DEC PART NO.	USED ON CODE	REF FIG NO.
4-	EXTERIOR, LPS32		N/A		
1	*Cartridge, Ozone Filter	G0131020			
2	*Holder, Ozone Cartridge	G0041640			
3	*Cover, Top	G0041649			
4	*Cover, Rear	G0041680			
5	*Tray, Side Exit	G0041675			
6	*Cover Assembly, Left	G0041671			
7	*Pivot, Left Corner	G0041638			
8	*Cover, Right	G0131551			
9	*Panel Unit, Operation Control		29-29641-01		
10	*Cover, Operation Panel	G0041610			
11	*Cover, Inner Left	G0131016			
12	*Cover, Inner Lower Right	G0041664			
13	*Cover, Inner Upper Right	G0041663			
14	*Cover, Front		29-30265-01		
	**Label	N/A			
	**Hinge	N/A			
	**Chain	N/A			
15	*Fan Unit, Process		29-29633-01		
16	*Switch, Toner Overflow		29-27369-01		
17	*Diode, Main Charger Zener		29-30266-01		
18	*Tray, Stacking		29-30267-01		
19	*Spring, Lower Tray		29-30268-01		
20	*Filter, Ozone (100K)		29-30264-01		
101	*Screw, Tapping M4 x 10	09654010B			
102	*Screw, Phi Hd w/Flat Washer M4	09514006B			
103	*Screw, Phi Pan Hd M4 X 10	03440100F			
104	*Screw, Phi Pan Hd M4 x 6	03140060B			
105	*Screw, Phi Pan Hd M3 x 5	03130050B			
106	*Screw, Phi Hd w/Flat Washer M4 x 8	09514008B			



LPS32-05-SC

Figure 5. PCB Rack Assembly

FIG. & ITEM NO.	DESCRIPTION	VENDOR PART NO.	DEC PART NO.	USED ON CODE	REF FIG NO.
5-	PCB RACK ASSEMBLY	N/A			2
1	*Fan Assembly, Controller		29-27484-01		
2	*Module, Engine Drive		29-29640-01		
3	*Module, Mother Board		29-29625-01		
4	*Bracket Assembly, I/F Connector		17-03381-01		
5	*Cover, PCB Rack		N/A		
6	*Bracket, Module		N/A		
7	*Bracket, Mother Board		N/A		
8	*Module, TURBO Controller		54-20830-03		
9	*Module, TURBO Memory Option (See Note)		54-20734-01	EF	
101	*Screw, Phi Hd w/Flat Washer M4 x 8	09514008B			
102	*Screw, Phi Pan Hd M4 x 6	03140060B			
	NOTE: Item 9 used on models LPS32-C7 & LPS32-C8 only.				

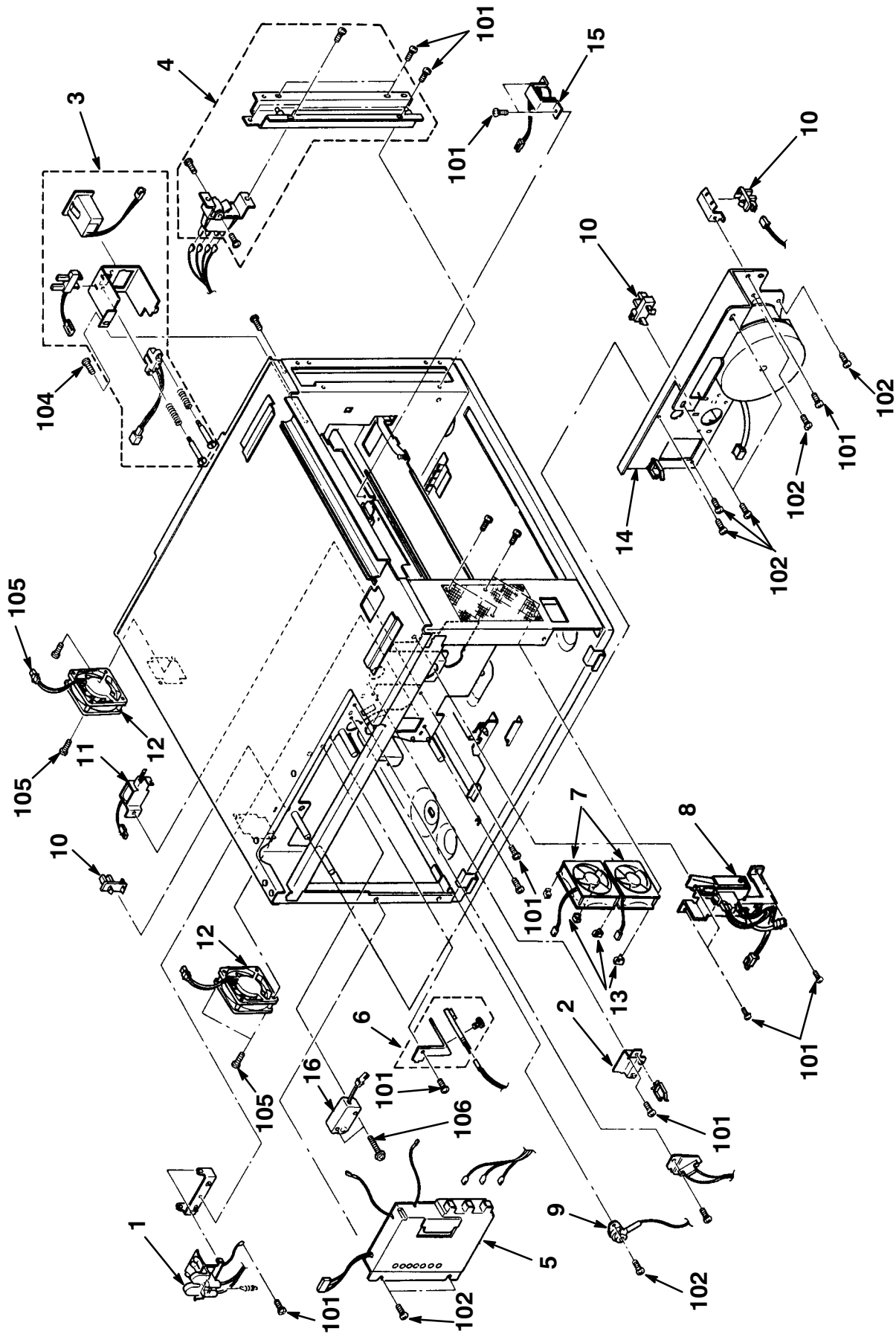

Figure 6. Electrical Assembly

FIG. & ITEM NO.	DESCRIPTION	VENDOR PART NO.	DEC PART NO.	USED ON CODE	REF FIG NO.
6-	ELECTRICAL ASSEMBLY	N/A			
1	*Receptacle Assembly, T/S Charger		17-03382-21		
2	*Sensor Set, Cleaning Unit		29-27362-01		
3	*Counter Unit, Total		29-29629-01		
4	*Switch, Left Cover Interlock		29-27363-01		
5	*Power Pack		29-29650-01		
6	*Sensor Set, OPC Drum		29-27365-01		
7	*Motor, Fan (D06T-24TU)		29-29649-01		
8	*Switch, Fusing Unit Interlock		29-29642-01		
9	*Receptacle, Main Charger		17-03382-20		
10	*Photo-Interrupter (EE-SX460-P2)		29-27373-01		
11	*Solenoid Assembly, Drum Separation Pawl		29-27400-01		
12	*Fan Motor Assembly, Development Cooling		29-29657-01		
13	*Bracket, Main Fan	G0041357			
14	*Drive Unit, Development		29-29636-01		
15	*Solenoid, Cleaning Roller (See Note)		29-29658-01		
16	*Motor, Wire Cleaning		29-29634-01		
101	*Screw, Phl Pan Hd M4 x 6	03140060B			
102	*Screw, Phl Hd w/ Flat Washer M4 x 8	09514008B			
103	*Screw, Phl Pan Hd M3 x 30	03130300B			
104	*Screw, Phl Pan Hd M4 x 4	03140040W			
105	*Screw, Phl Pan Hd w/Flat Washer 3 x 20	09513020B			
106	*Screw, Phl Pan Hd w/Flat Washer 3 x 25	09513025B			
	NOTE: Item 15 may be ECO'd out at a later date.				

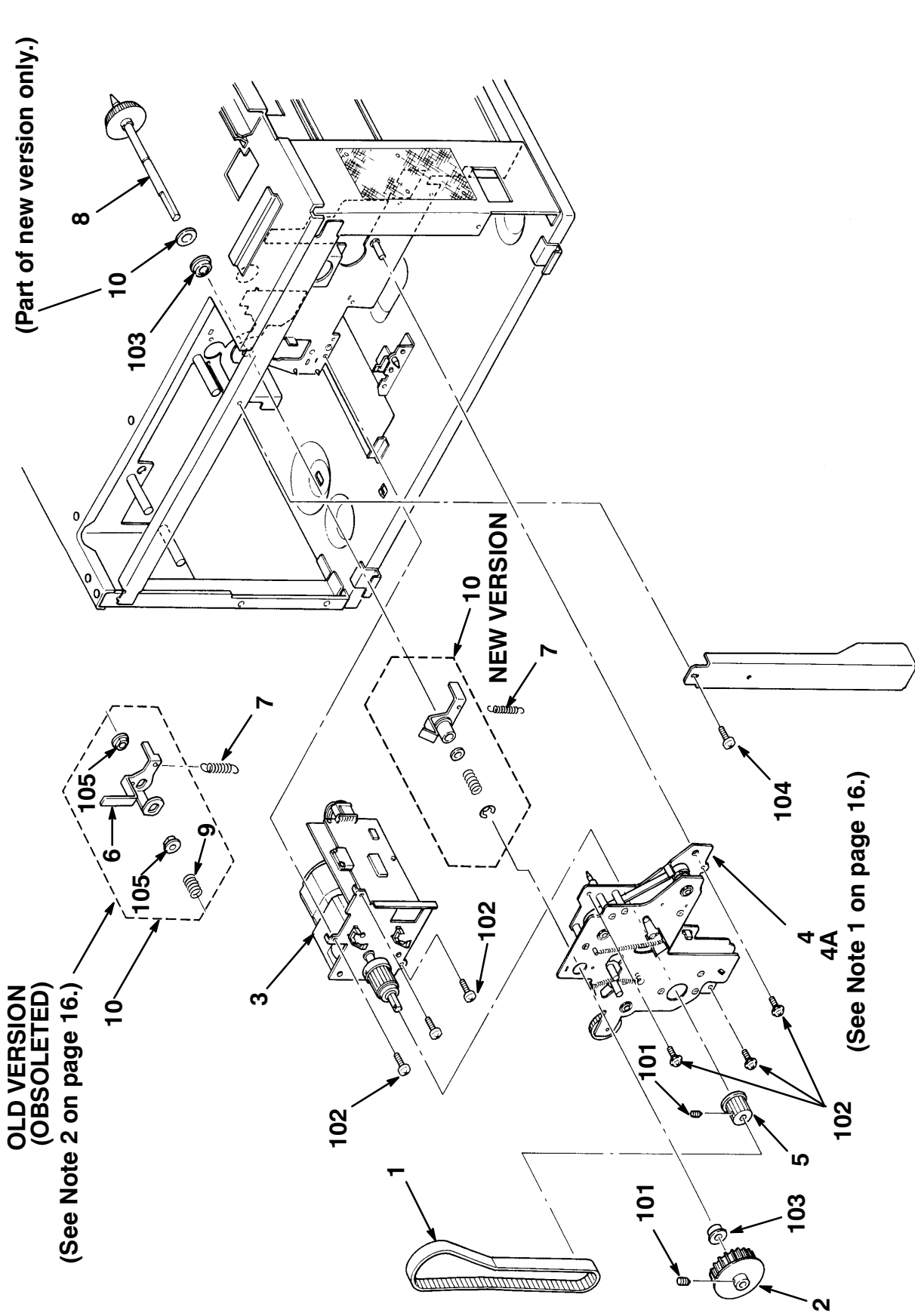
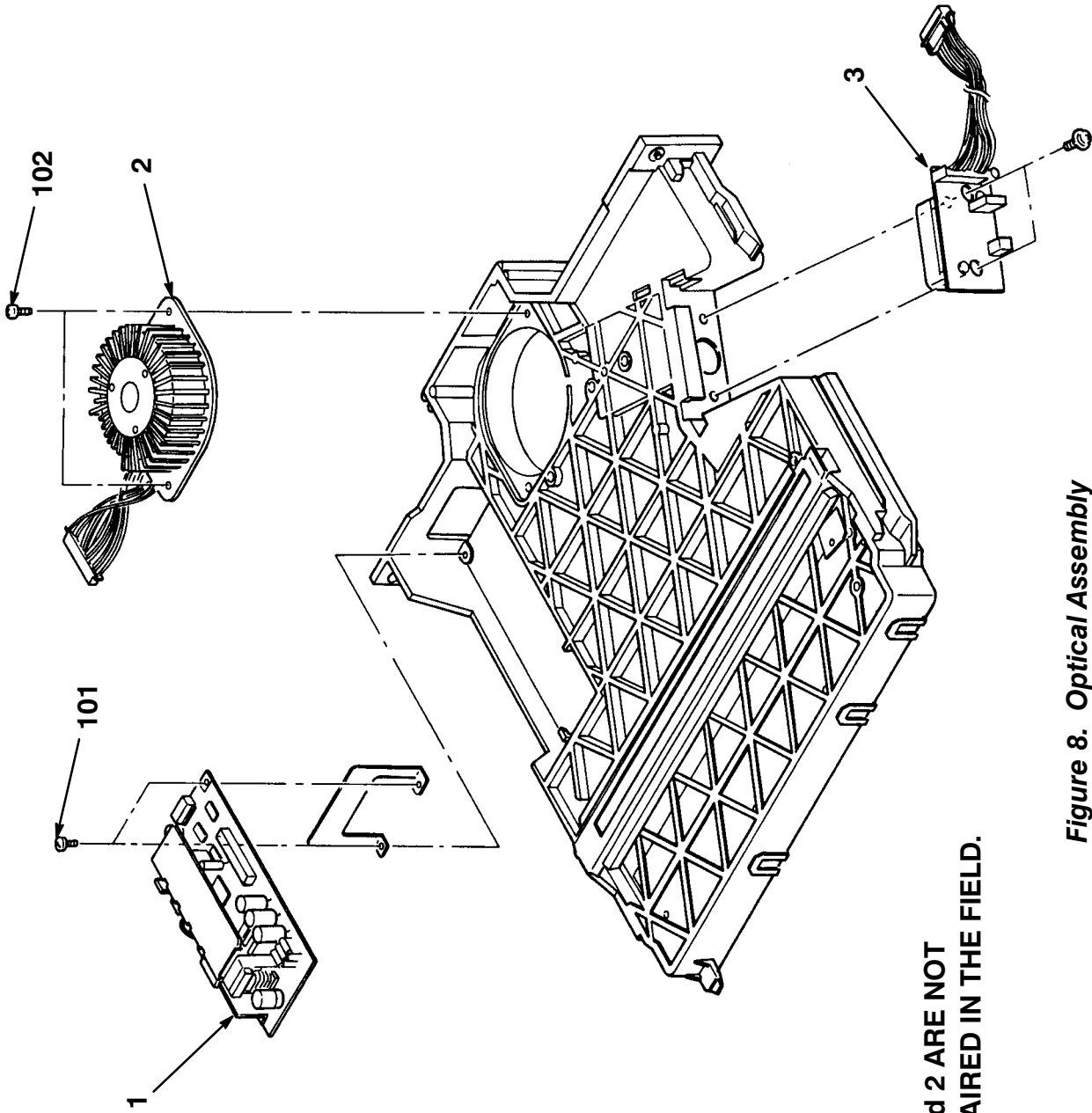

Figure 7. Drive Assembly, Main

FIG. & ITEM NO.	DESCRIPTION	VENDOR PART NO.	DEC PART NO.	USED ON CODE	REF FIG NO.
7-	DRIVE ASSEMBLY, MAIN	N/A			
1	*Belt, Timing (166XL)		29-27374-01		
2	*Pulley, (32T)		29-27380-01		
3	*Motor Unit, Main		29-29630-01		
4	*DRIVE UNIT, MAIN (See Note 1)		29-29628-01		
4A	**Clutch, Registration		N/A		
5	*Pulley, OPC Drive	GB030028			
6	*Feeler, Drum Change Sensor (See Note 2)	N/A			
7	*Spring, Feeler Drum Change Sensor		29-30270-01		
8	*Shaft, Drive, OPC Drum	GD015001			
9	*Spring, Drum Change Feeler Pressure (See Note 2)	N/A			
10	*Kit, OPC Reset Feeler (replaces Item 6)		29-30349-01		
101	*Screw, Hex Headless Set (M4 x 5)	05740050E			
102	*Screw, Phi Hd w/Flat Washer (M4 x 8)	09514008B			
103	*Bearing, Ball (8 x 16 x 5MM)	08053368			
104	*Screw, Phi Pan Hd (M4 x 6)	03140060B			
105	*Bushing (8 x 10 x 6MM) (See Note 2)	N/A			
	<p>NOTE 1: Registration Clutch is included in Main Drive Unit – Clutch is not orderable separately as in the LPS20. Order Main Drive Unit – DEC Part Number 29-29628-01.</p> <p>NOTE 2: New OPC Reset Feeler Kit, Item 10, should be used rather than replacing individual components. The newkit REPLACES the old kit.</p>				



NOTE: ITEMS 1 and 2 ARE NOT TO BE REPAIRED IN THE FIELD.

Figure 8. Optical Assembly

FIG. & ITEM NO.	DESCRIPTION	VENDOR PART NO.	DEC PART NO.	USED ON CODE	REF FIG NO.
8-	OPTICAL ASSEMBLY		29-29631-01		2
1	*Module, Scanner Motor Drive (See Note)	N/A			
2	*Motor, Scanner (See Note)	N/A			
3	*Diode Assembly, Laser	N/A			
101	*Screw, Phi Pan Hd Screw (M3 x 5)	03130050B			
102	*Screw, Phi Pan Hd Screw (M4 x 10)	03140100B			
	<p data-bbox="289 653 789 716">NOTE : ITEMS 1 and 2 ARE NOT TO BE REPAIRED IN THE FIELD.</p>				

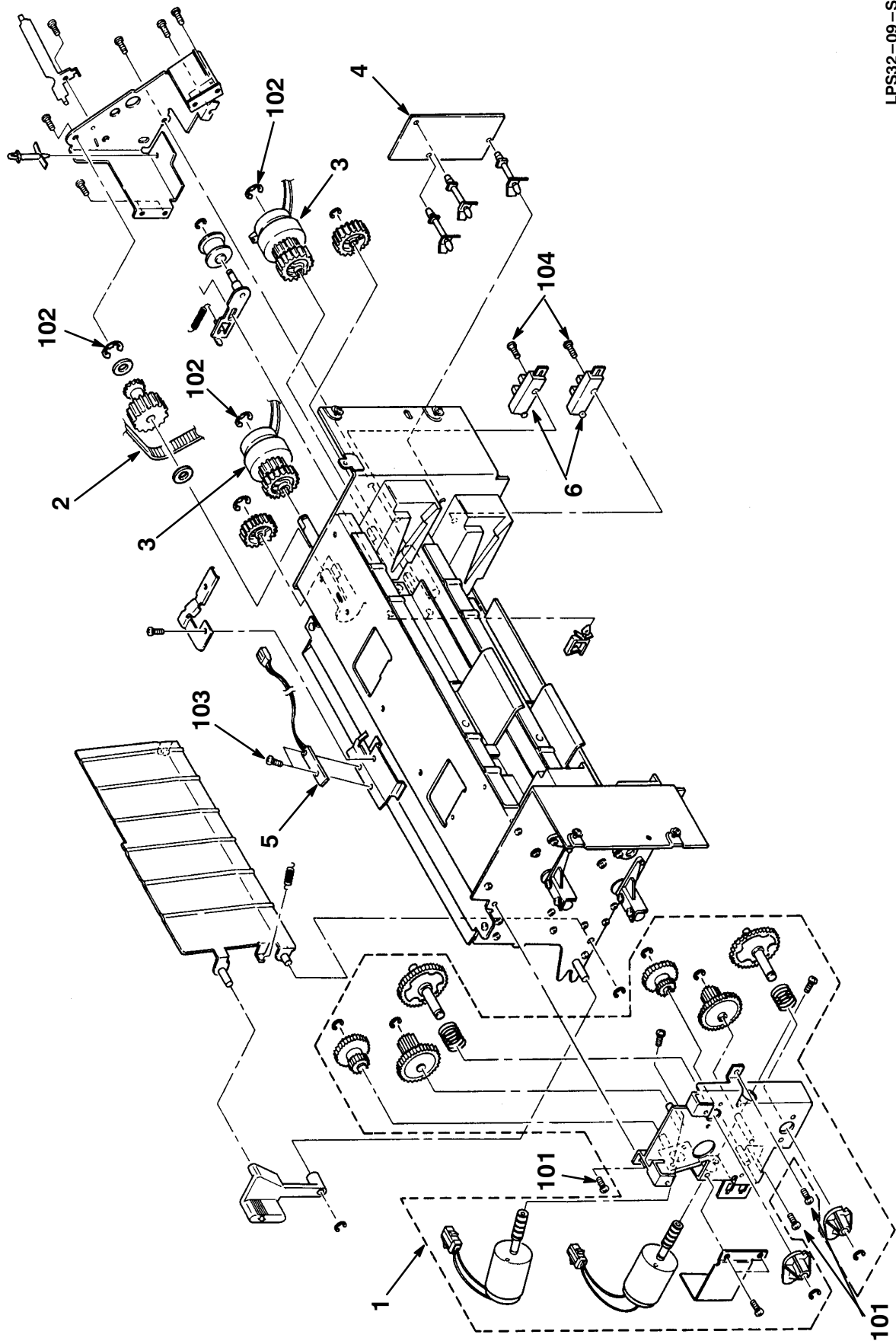

LPS32-09-SC

Figure 9. Feed Assembly, Paper (Cassette)

FIG. & ITEM NO.	DESCRIPTION	VENDOR PART NO.	DEC PART NO.	USED ON CODE	REF FIG NO.
9-	FEED ASSEMBLY, PAPER (CASSETTE)		29-29632-01		2
1	*Motor Assembly, Cassette		12-36097-01		
2	*Timing Belt, (116XL)		12-37042-01		
3	*Clutch, (TMO-F-01)		12-37052-01		
4	*Module, Paper Feed Unit	G0045400			
5	*Photoreflector		12-37049-01		
6	*Photo-interrupter		29-27397-01		
101	*Screw, Phi Pan Hd M4 x 6	03140060B			
102	*Ring, Retaining M6	07200060E			
103	*Screw, Phi Sunk M3 x 6	03230060B			
104	*Screw, Phi Pan Hd M4 x 10	03140100B			

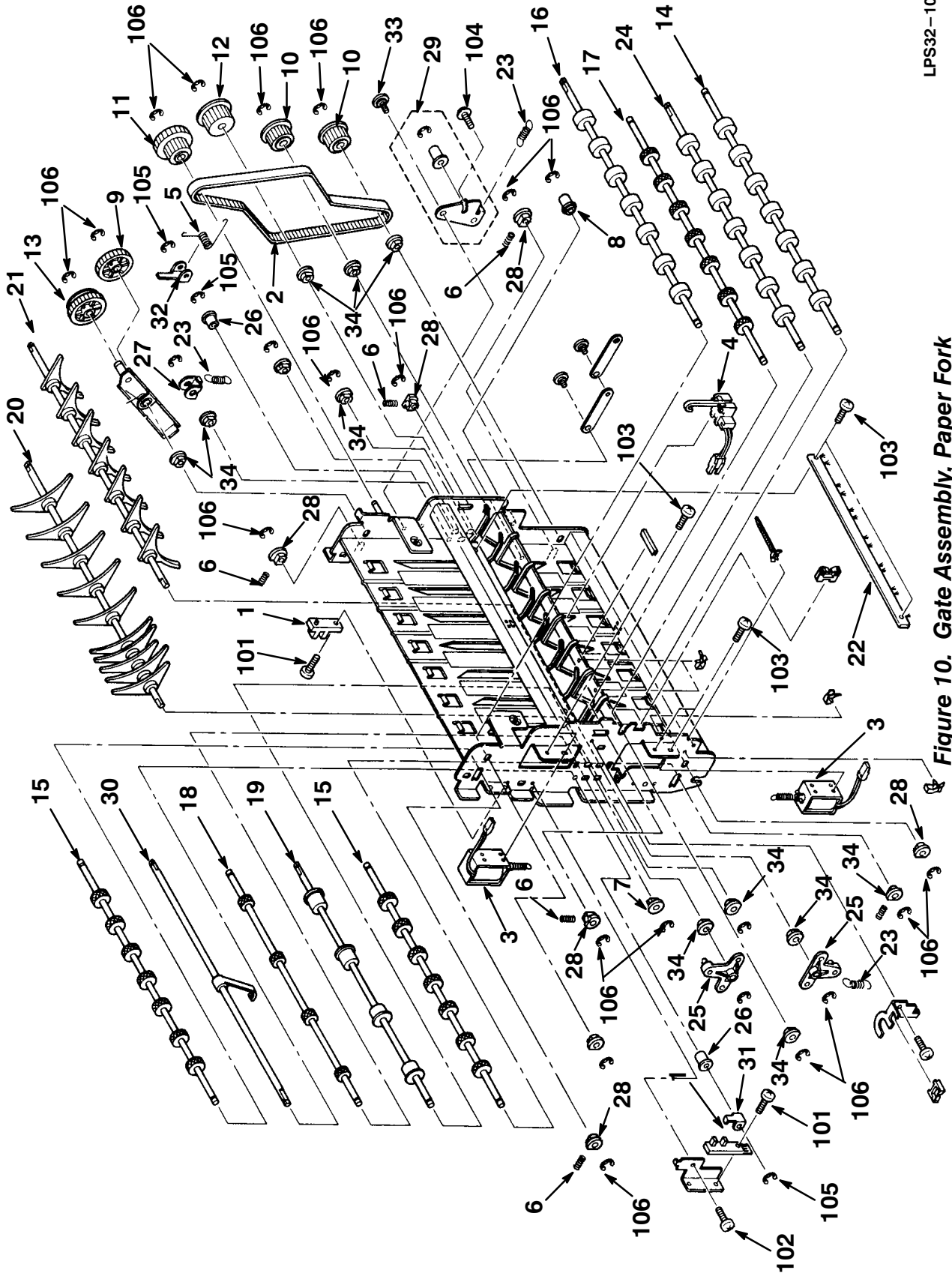

Figure 10. Gate Assembly, Paper Fork

FIG.& ITEM NO.	DESCRIPTION	VENDOR PART NO.	DEC PART NO.	USED ON CODE	REF FIG NO.
10-	GATE ASSEMBLY, PAPER FORK		29-29639-01		2
1	*Photo-interrupter		29-27397-01		
2	*Belt, Timing (256MXL)		29-30273-01		
3	*Solenoid Assembly, Fork Gate		29-30274-01		
4	*Photo-interrupter, Fusing Exit		29-30275-01		
5	*Spring, Overflow Feeler	G0134814			
6	*Spring, 100GF	GA063013			
7	*Bushing, 6mm	GA080004			
8	*Pulley, Idler (11.2mm)	GA134003			
9	*Gear, Fork Gate Relay	GB013046			
10	*Pulley, Fork Gate One Way	GB033002			
11	*Gear, Pulley, Fork Gate	GB017030			
12	*Pulley, MXL33	GB030029			
13	*Gear, Drive Fork Gate	GB013045			
14	*Roller, Fork Gate Bottom Drive	G0134834			
15	*Roller, Idle - 2	GF022002			
16	*Roller, Fork Gate Drive	GF020021			
17	*Roller, Fork Gate Entrance Idle	G0134838			
18	*Roller, Fork Gate Idle Side Exit	GF022005			
19	*Roller, Fork Gate Drive Side Exit	GF023003			
20	*Fork Gate, Upper	G0134896			
21	*Fork Gate, Lower	G0134846			
22	*Brush, Antistatic Fusing Exit	GA120006			
23	*Spring, Fork Gate	G0134811			
24	*Roller, Fork Gate Drive Entrance	G0134836			
25	*Lever, Fork Gate	G0134870			
26	*Bushing, Pinch Roller	584 02416			
27	*Bracket, Fork Gate Upper	G0134883			
28	*Bushing, Upper Registration Roller	52052697			
29	*Tightener Assembly - 1	G0134874			
30	*Feeler, Side Exit Overflow	G0134886			
31	*Interrupter, Side Exit Overflow	G0046951			
32	*Bracket, Side Exit Feeler	G0134881			
33	*Screw, Stepped M4	AA143076			
34	*Bushing 6mm	GA080002			
101	*Screw, Phi Pan Hd M4 x 10	03140100B			
102	*Screw, Phi Pan Hd M4 x 6	03140060B			
103	*Screw, Phi Pan Hd M3 x 4	03130040B			
104	*Screw Phi Hd w/Flat Washer M4 x 8	09514008B			
105	*Ring, Retaining M2.5	07200025E			
106	*Ring, Retaining M2.5	07200040E			

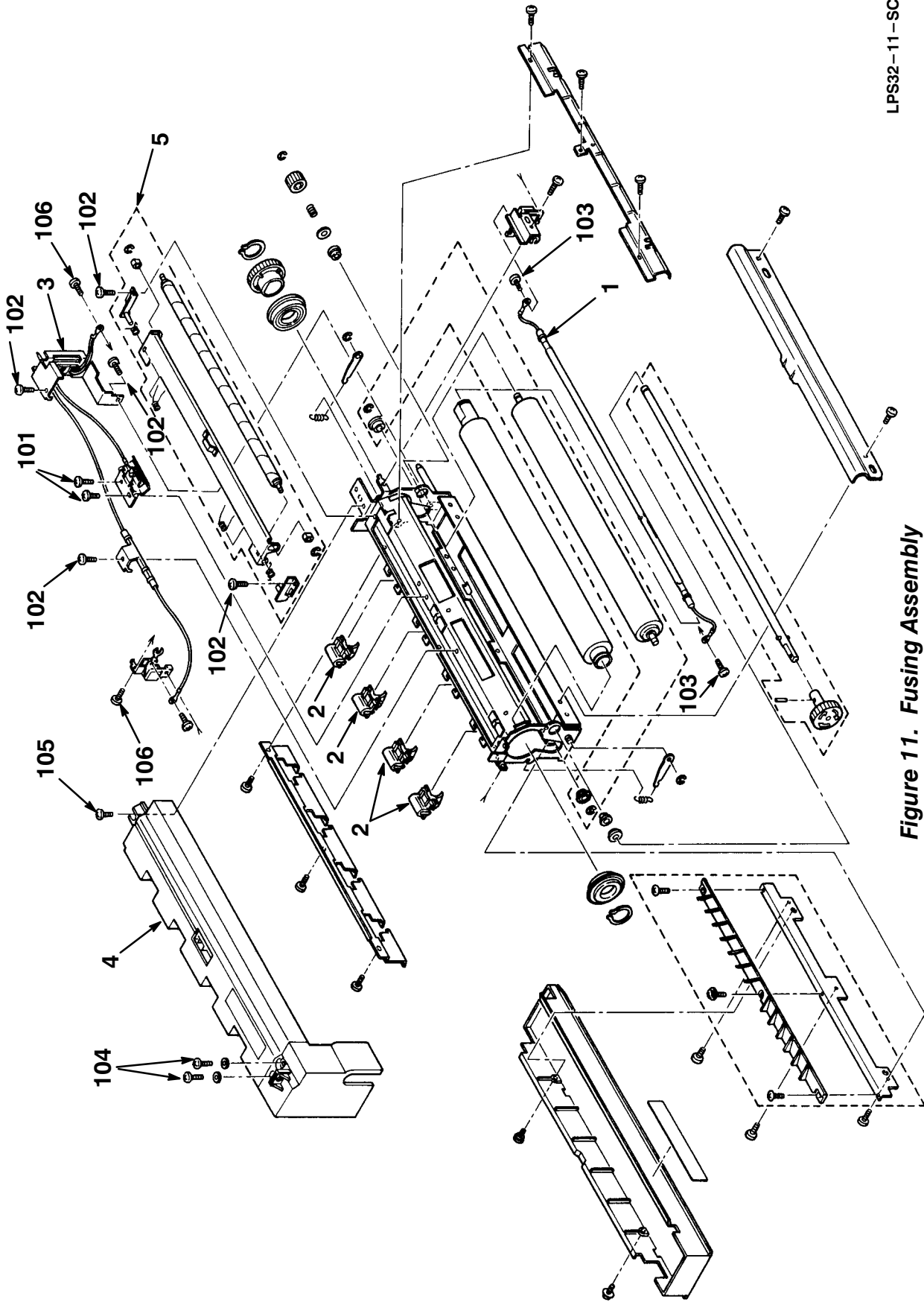

Figure 11. Fusing Assembly

FIG. & ITEM NO.	DESCRIPTION	VENDOR PART NO.	DEC PART NO.	USED ON CODE	REF FIG NO.
11-	FUSING ASSEMBLY (100V) FUSING ASSEMBLY (200V)		29-29637-01 29-29638-01		2,22 2,22
1	*Lamp, Fusing (100V) *Lamp, Fusing (200V)		29-30276-01 29-30277-01		
2	*Pawl, Fusing Unit Separation		29-29654-01		
3	*Thermistor and Fuse Assembly		29-30278-01		
4	*Cover, Fusing	G0134616			
5	*Roller Assembly, Cleaning (See Note)		N/A		
101	*Screw, Phi Pan Hd M3 x 5	03130050B			
102	*Screw, Phi Pan Hd M4 x 6	03140060B			
103	*Screw, Phi Pan Hd M3 x 3	08011135			
104	*Screw, Phi Pan Hd w/Flat Washer M4	09514006B			
105	*Screw, Stepped M4	54195714			
106	*Screw, Phi Pan Hd M3 x 3	03130030B			
	NOTE: Item 5 may be ECO'd out at a later date.				

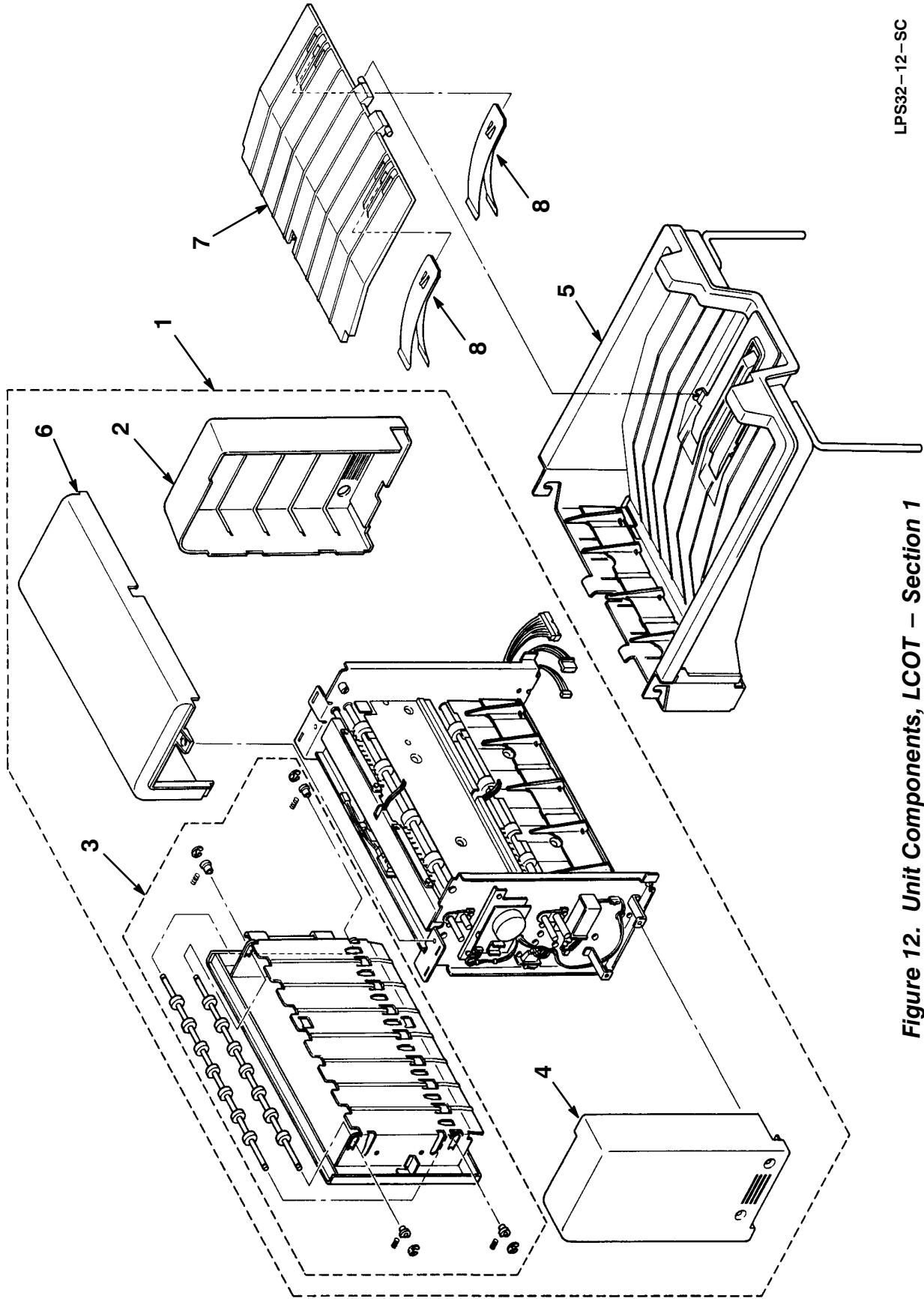
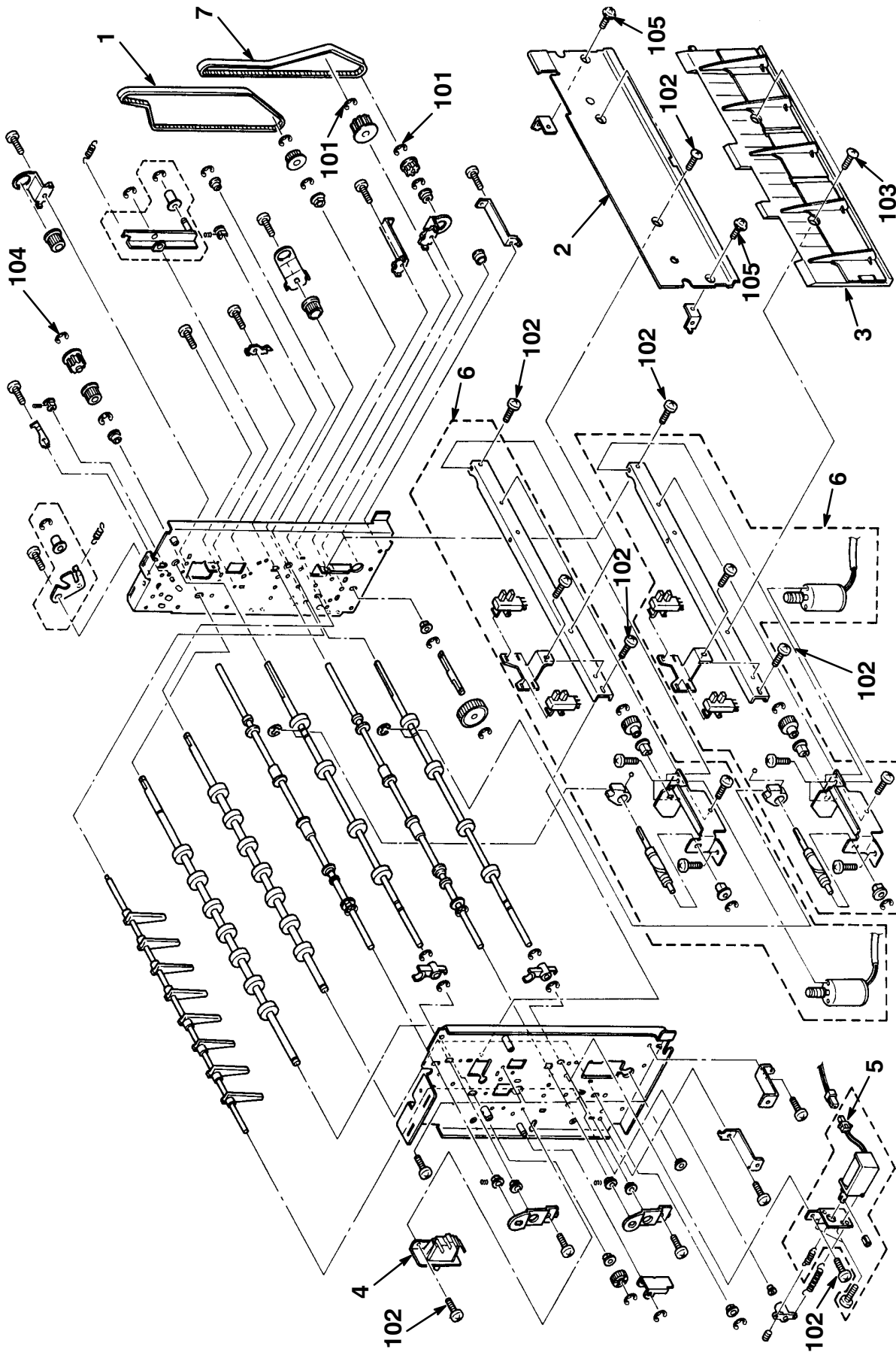

Figure 12. Unit Components, LCOT – Section 1

FIG. & ITEM NO.	DESCRIPTION	VENDOR PART NO.	DEC PART NO.	USED ON CODE	REF FIG NO.
12-	UNIT COMPONENTS – (LCOT) SECTION 1 LARGE CAPACITY OUTPUT TRAY	N/A			20
1	*LCOT		29-29644-01		12A 12B
2	**Cover, LCOT Rear	G6461531			
3	**Cover, LCOT Left	G6464931			
4	**Cover, LCOT Front	G6461530			
5	**Tray, LCOT Upper Exit		29-27392-01		
6	**Cover, LCOT Top	G6461532			
7	*Tray, Stacking		29-30267-01		
8	*Spring, Tray Upper		29-30282-01		



LPS32-12A-SC

Figure 12A. Unit Components - Section 2, LCOT

FIG. & ITEM NO.	DESCRIPTION	VENDOR PART NO.	DEC PART NO.	USED ON CODE	REF FIG NO.
12A-	UNIT COMPONENTS – SECTION 2 (LCOT) LARGE CAPACITY OUTPUT	N/A			12
1	*Belt, Timing (271MXL)		29-30283-01		
2	*Cover, Upper Right (LCOT)	G6274868			
3	*Cover, Lower Right (LCOT)	G6274856			
4	*Switch, Interlock (LCOT, Left Cover)		12-37037-01		
5	*Solenoid Assembly, LCOT		29-30284-01		
6	*Stay Assembly, Job Separation (LCOT)		29-30285-01		
7	*Belt, Timing (194XL)		29-30286-01		
101	*Ring, Retaining (M6)	07200060E			
102	*Screw, Phi Pan Hd (M4 x 6)	03140060B			
103	*Screw, Phi Truss Hd Screw (M4 x 6)	03440060F			
104	*Ring, Retaining (M4)	07200040E			
105	*Screw, Phi Hd w/Flat Washer (M4 x 8)	09514008B			

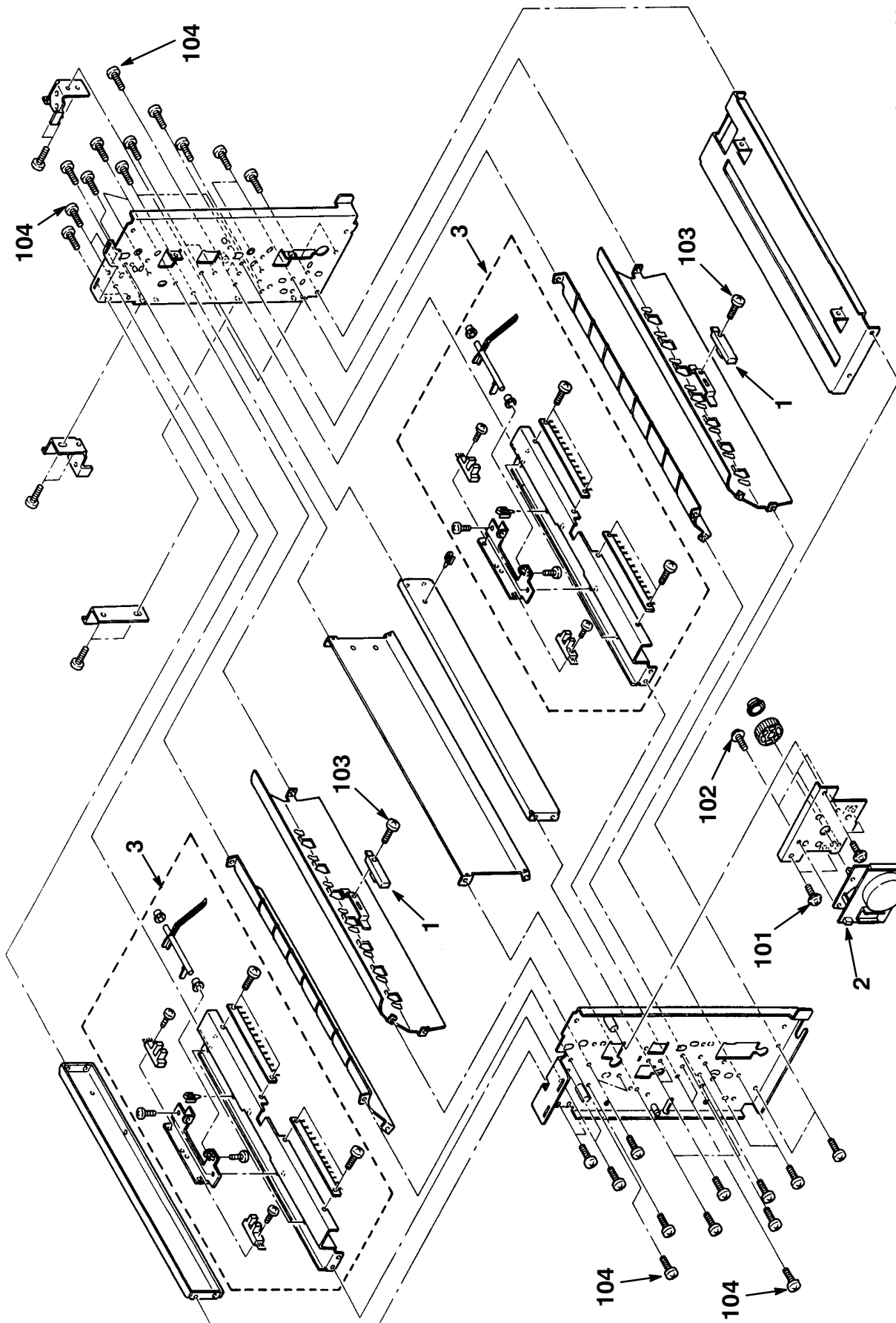

LPS32-12B-SC

Figure 12B. Unit Components - Section 3, LCOT

FIG. & ITEM NO.	DESCRIPTION	VENDOR PART NO.	DEC PART NO.	USED ON CODE	REF FIG NO.
12B-	UNIT COMPONENTS – SECTION 3 (LCOT) LARGE CAPACITY OUTPUT TRAY	N/A			12
1	*Photoreflector (GP2A10)		29-30287-01		
2	*Motor Assembly, Exit Drive (LCOT)		29-30288-01		
3	*Stay Assembly, Upper (Feeler Exit) (LCOT)		29-30347-01		
101	*Screw, Phi Pan w/Flat Washer M4 x 8	09514008B			
102	*Screw, Phi Pan w/Flat Washer M3 x 5	09513005B			
103	*Screw, Phi Pan Hd M3 x 8	03130080B			
104	*Screw, Phi Pan Hd M4 x 6	03140060B			

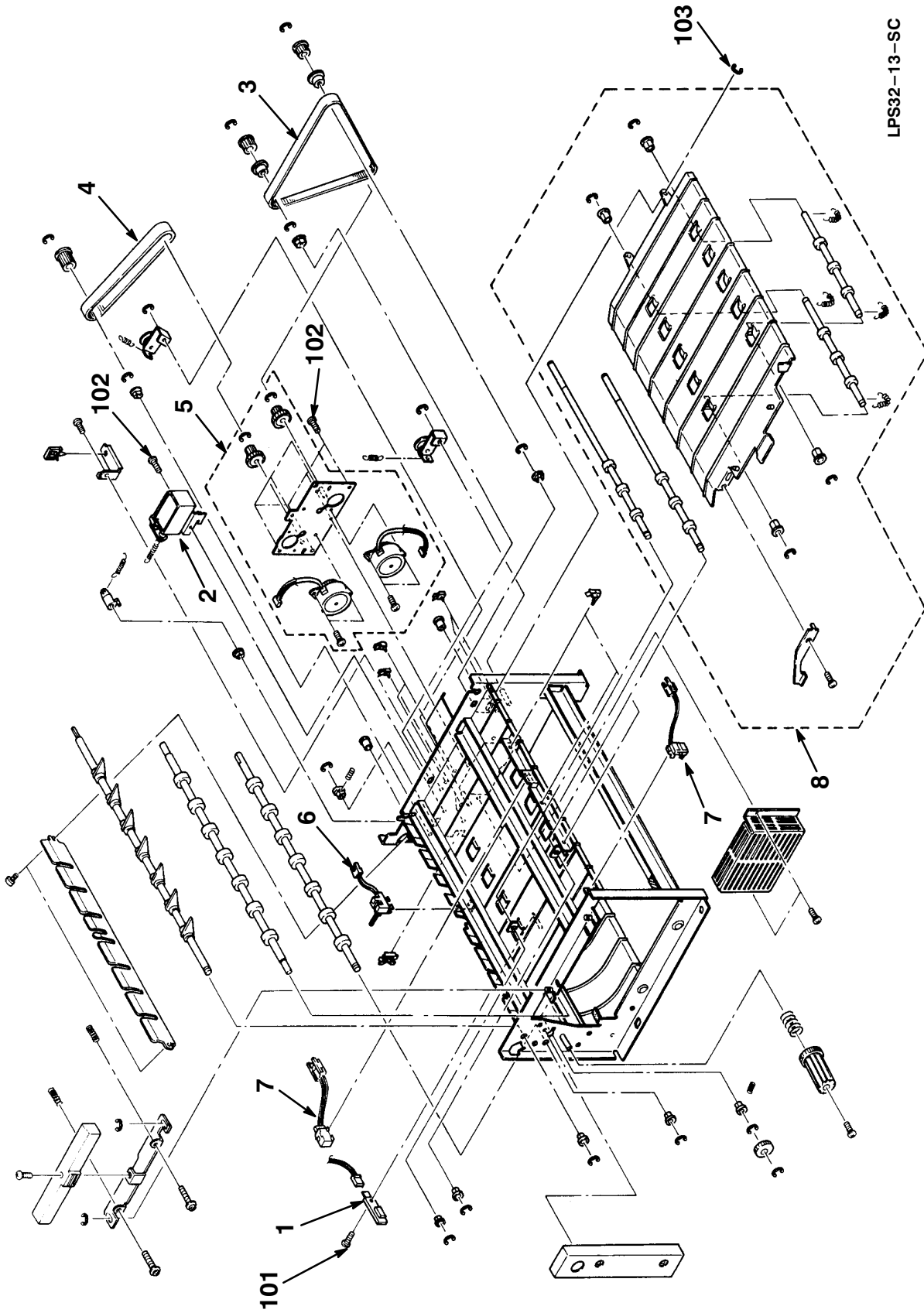

LPS32-13-SC

Figure 13. DPX Assembly (Duplexer)

FIG. & ITEM NO.	DESCRIPTION	VENDOR PART NO.	DEC PART NO.	USED ON CODE	REF FIG NO.
13-	*DPX ASSEMBLY (DUPLEXER) (30-39034-06)		LPS3X-DA		
1	*Photoreflector (GP2A10)		29-30287-01		
2	*Solenoid Asembly, DPX		29-30290-01		
3	*Belt, Timing (225MXL)		12-37045-01		
4	*Belt, Timing (140MXL)		29-30291-01		
5	*Motor Assembly, DPX Feed		29-30292-01		
6	*Photosensor w/Actuator		29-30297-01		
7	*Photosensor w/Actuator		29-30289-01		
8	*Guide Assembly, DPX Transport		29-30298-01		
101	**Screw, Phi Pan Hd M3 x 8	03130080B			
102	**Screw, Phi Pan Hd M4 x 6	03140060B			
103	**Ring, Retaining (M3)	07200030E			

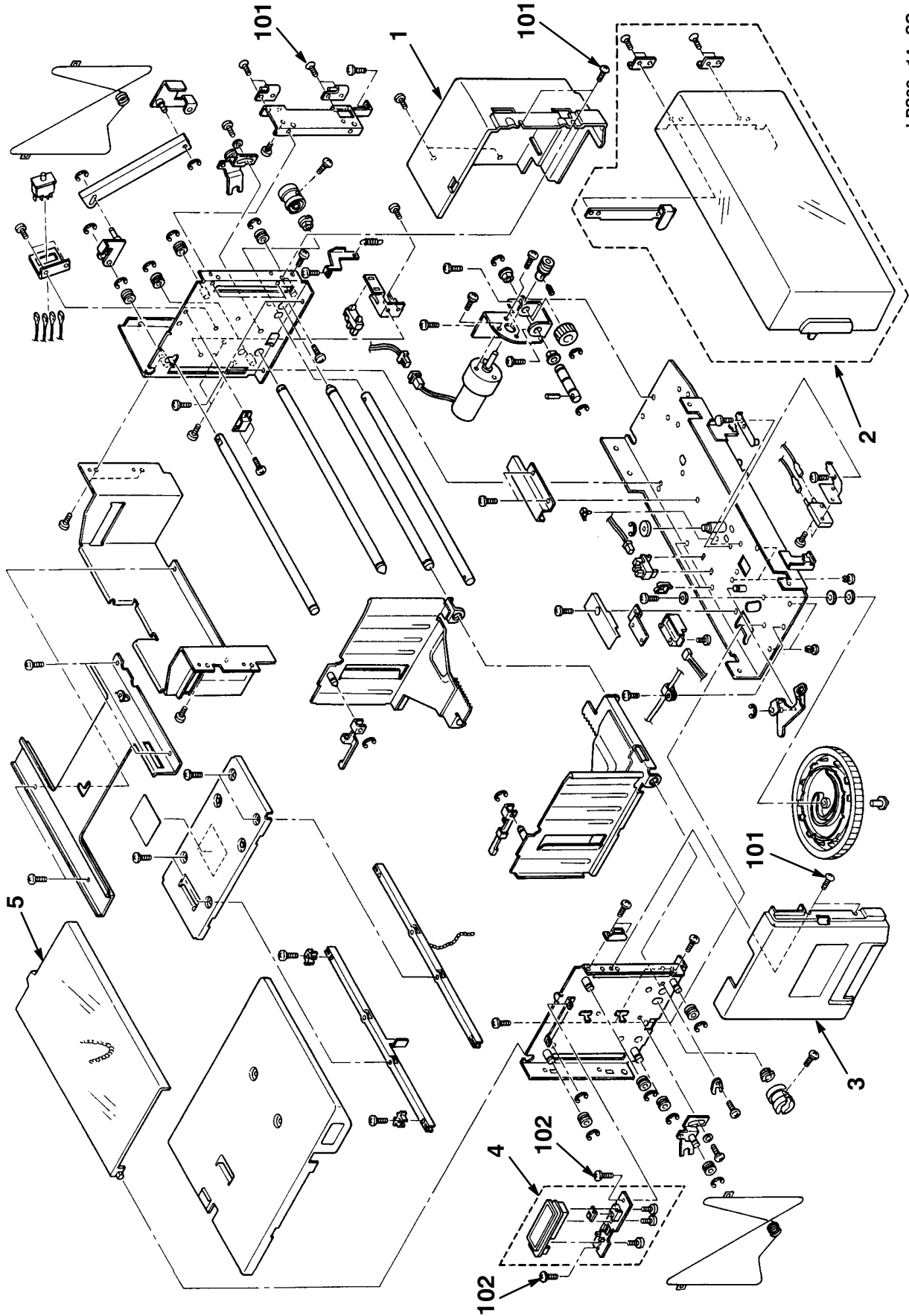

Figure 14. LCIT (Large Capacity Input Tray)

FIG. & ITEM NO.	DESCRIPTION	VENDOR PART NO.	DEC PART NO.	USED ON CODE	REF FIG NO.
14-	LCIT (LARGE CAPACITY INPUT TRAY) Includes 7 Trays (30-39034-05)		LPS3X-BA		1
1	*Cover, Rear (LCIT)		29-30294-01		
2	*Cover, Right (LCIT)		29-30295-01		
3	*Cover, Front (LCIT)		29-30296-01		
4	*Panel, Operation (LCIT)		29-30260-01		
5	*Cover, Top (LCIT)		29-30261-01		
101	*Screw, Phi Truss Hd M4 x 8	03440080F			
102	*Screw, Phi Pan Hd M3 x 4	03140040B			
	TRAY KITS for LCIT (Not Shown)				
	Kit 1, LCIT (A4/LT)		LPS3X-LA		
	Kit 2, LCIT (5 Trays)		LPS3X-LB		
	Kit 3, LCIT (7 Trays)		LPS3X-LC		

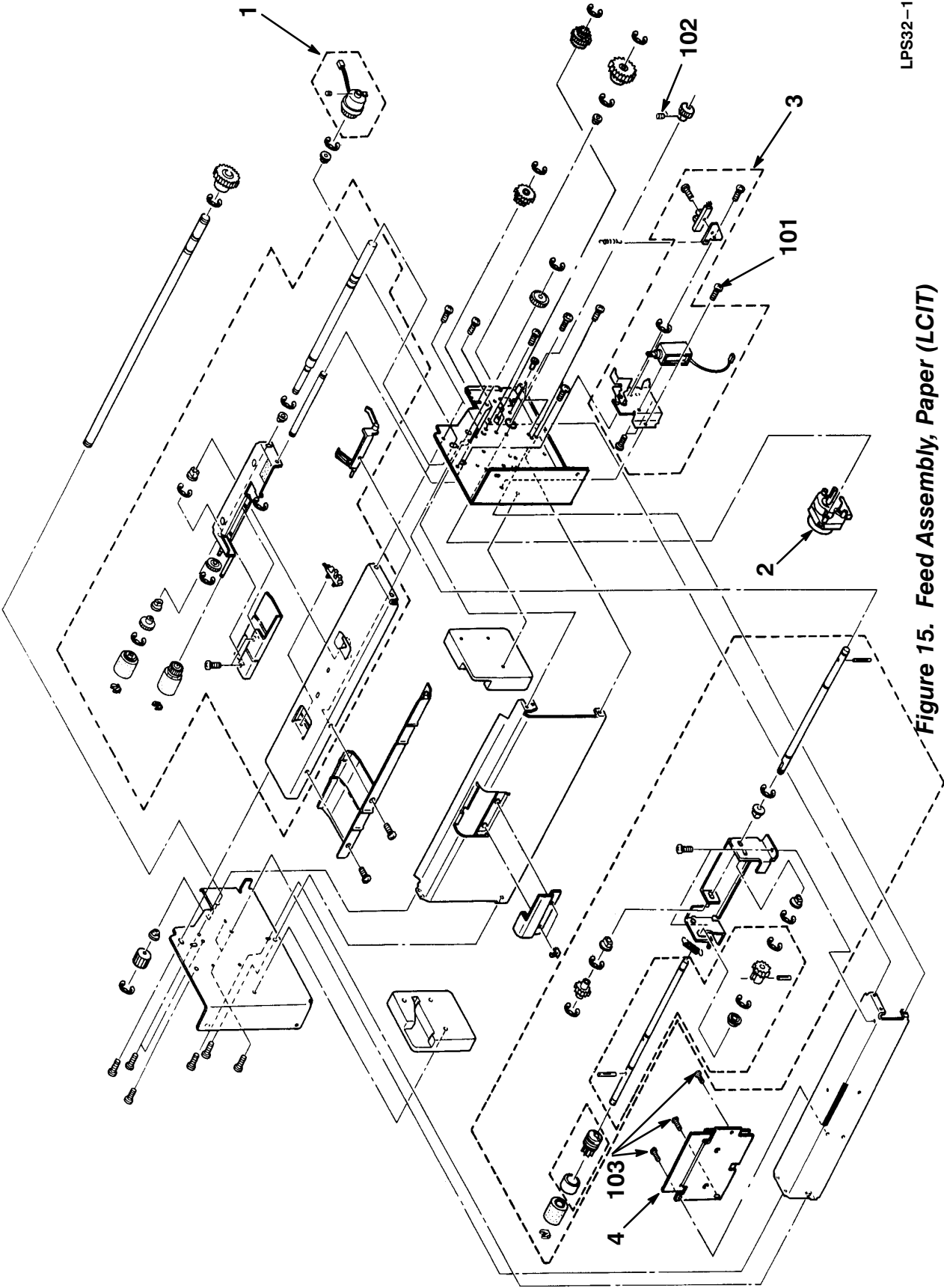
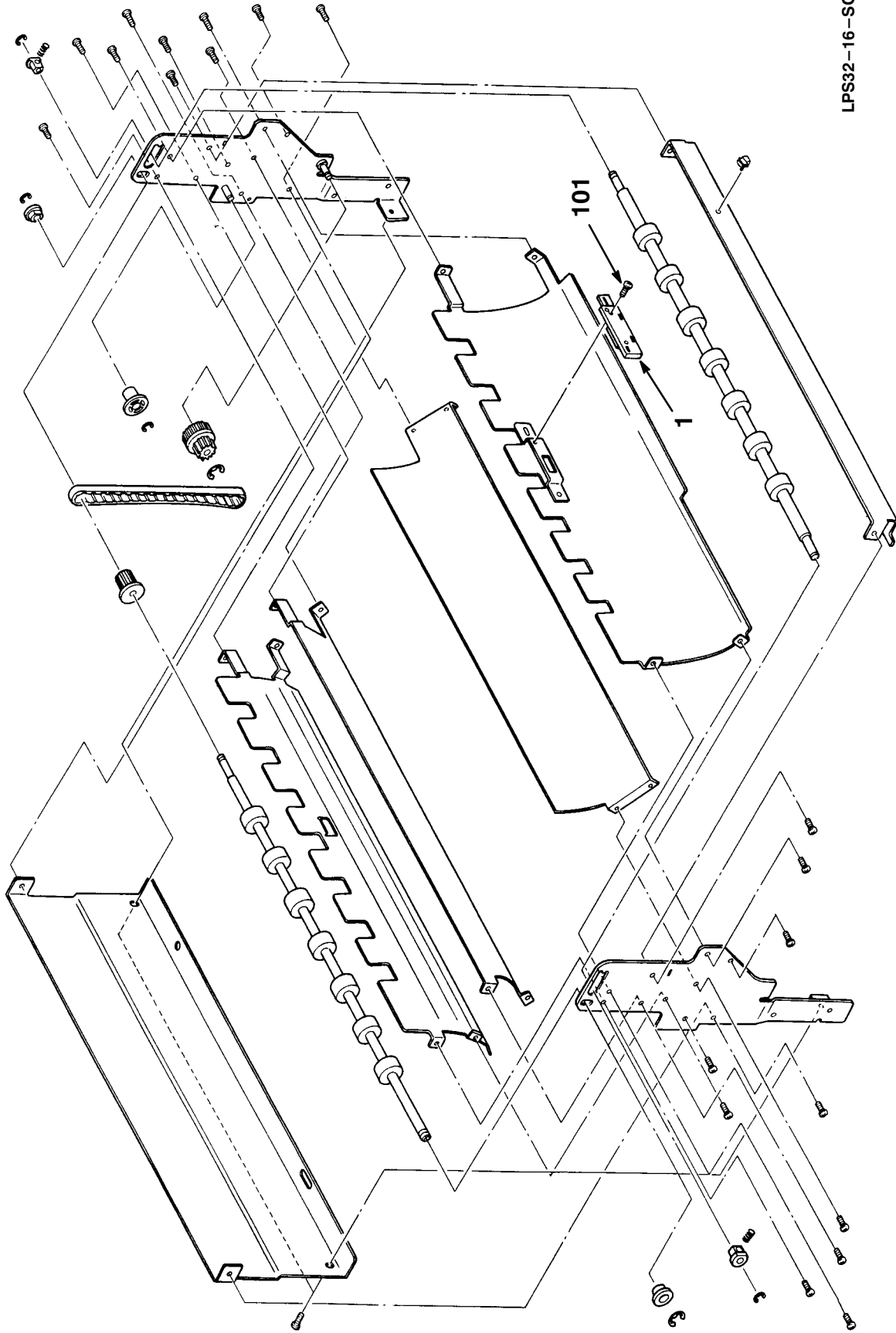

Figure 15. Feed Assembly, Paper (LCIT)

FIG. & ITEM NO.	DESCRIPTION	VENDOR PART NO.	DEC PART NO.	USED ON CODE	REF FIG NO.
15-	FEED ASSEMBLY, PAPER (LCIT)		29-29645-01		3
1	*Clutch, (TMO-F-03)		12-37052-02		
2	*Motor Assembly, Table Feed		29-30300-01		
3	*Solenoid Assembly, (LCIT FEED)		29-30301-01		
4	*Module, Feed Motor Driver		29-30293-01		
101	*Screw, Phi Pan Hd M4 x 6	03140060B			
102	*Screw, Hex Headless Set M4 x 5	05740050E			
103	*Screw, Phi Pan Hd M4 x 4	03140040W			



LPS32-16-SC

Figure 16. Feed Assembly, Table

FIG. & ITEM NO.	DESCRIPTION	VENDOR PART NO.	DEC PART NO.	USED ON CODE	REF FIG NO.
16-	FEED ASSEMBLY, TABLE		29-27358-01		3
1	*Photorelector		29-30287-01		
101	*Screw, Phl Pan Hd M3 x 8	03130080B			

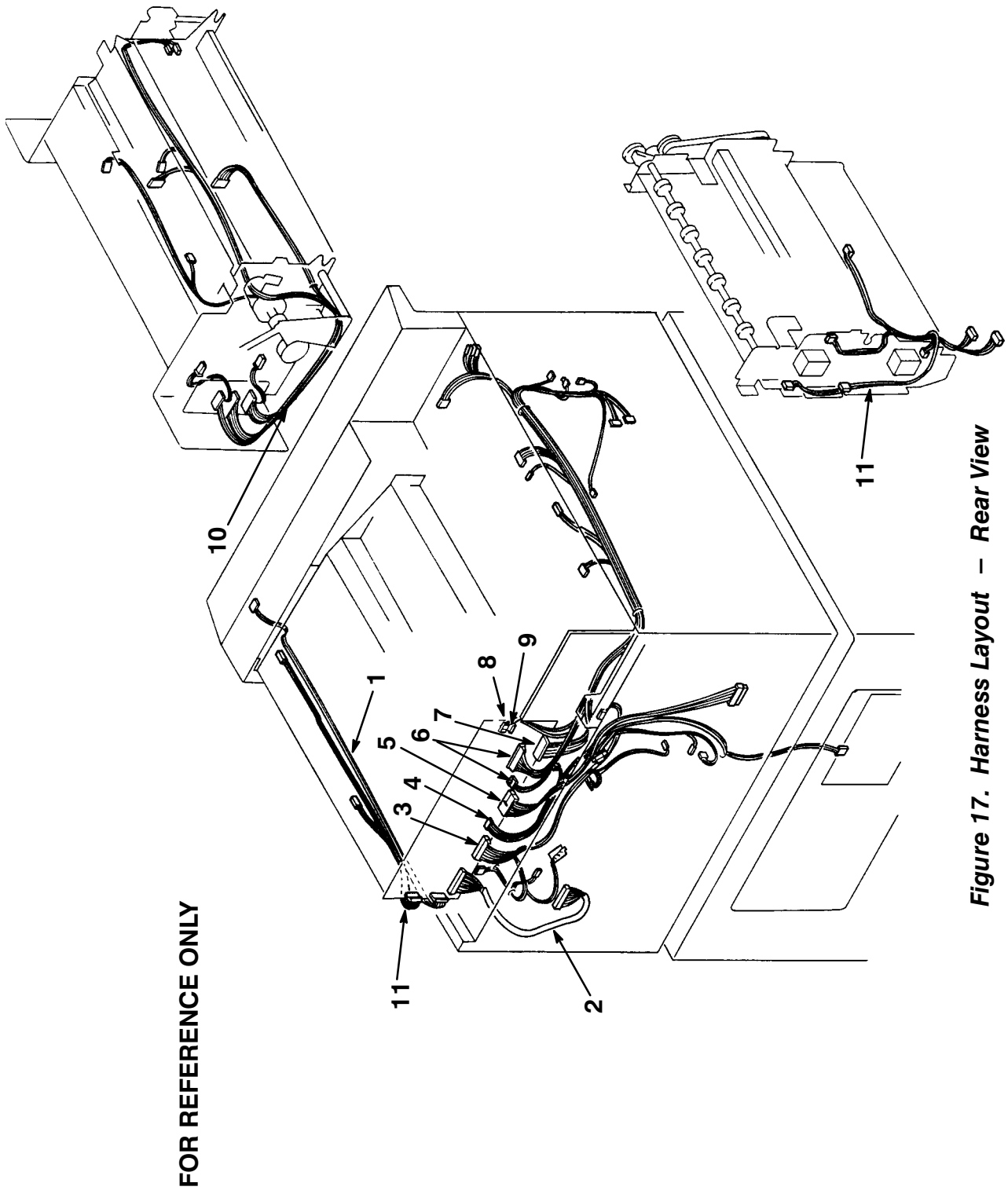
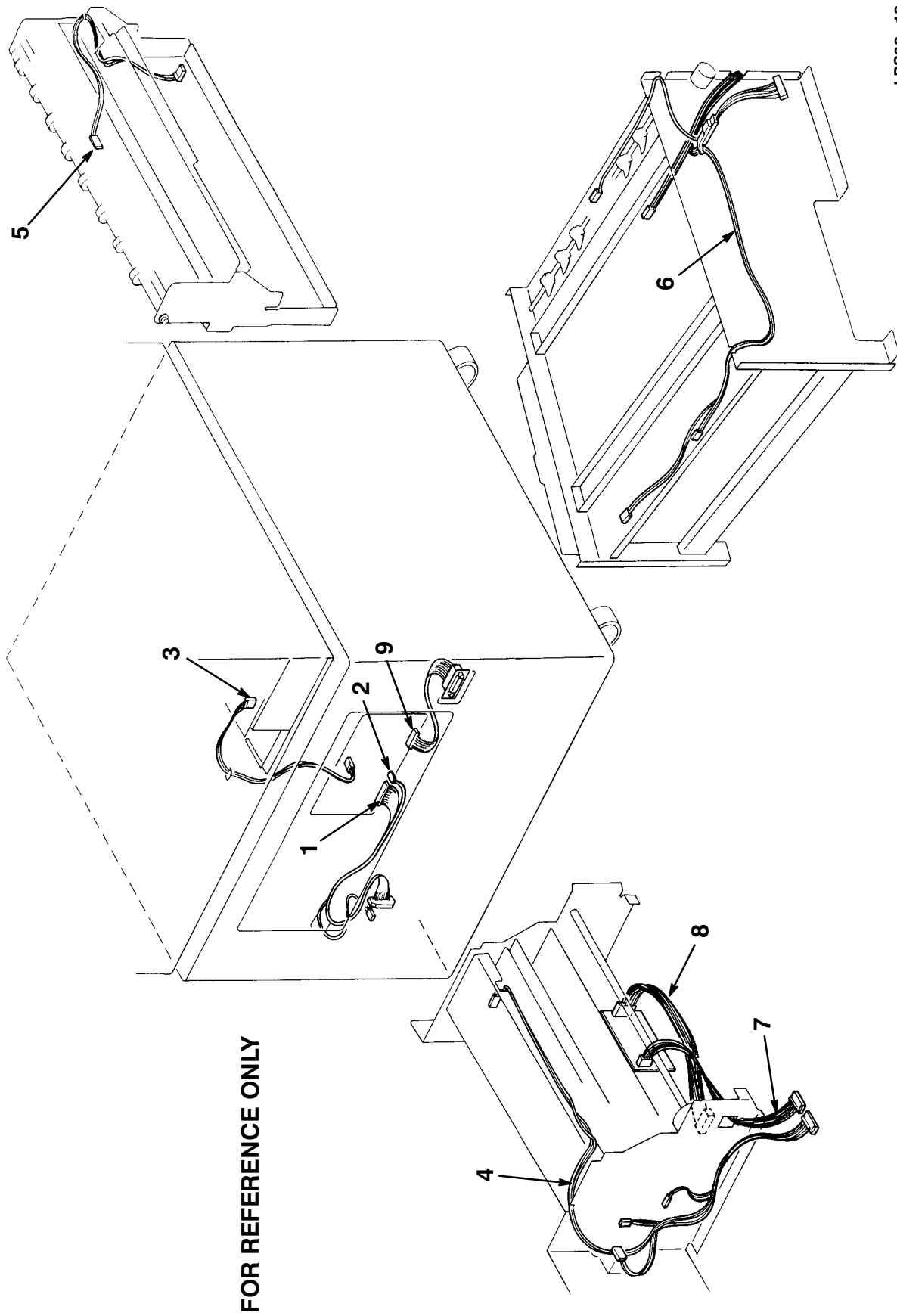

Figure 17. Harness Layout - Rear View

FIG. & ITEM NO.	DESCRIPTION	VENDOR PART NO.	DEC PART NO.	USED ON CODE	REF FIG NO.
17-	HARNES LAYOUT – REAR VIEW	N/A			
1	*Harness, Relay, Operation Panel	G0045580			
2	*Harness, Relay, Paper Feed Unit	G0045542			
3	*Harness, Relay, Process Unit	G0045554			
4	*Harness, Feed Drive	G0135560			
5	*Harness, Relay, PSU	G0135540			
6	*Harness, Left Side	G0135564			
7	*Harness, Relay, Optical Unit	G0135530			
8	*Harness, Communication, Table	G0135520			
9	*Cable Optical Fiber, 600MM	GW030001			
10	*Harness, Paper Feed Unit	G0045544			
11	*Harness, Fork Gate Unit	G0135566			
12	*Harness, Development Fan Relay	G0135547			
	<p data-bbox="289 831 802 890">NOTE: ALL HARNES LAYOUTS ARE SHOWN FOR REFERENCE ONLY,</p>				



LPS32-18-SC

Figure 18. Harness Layout, Table

FIG. & ITEM NO.	DESCRIPTION	VENDOR PART NO.	DEC PART NO.	USED ON CODE	REF FIG NO.
18-	HARNESS LAYOUT – TABLE	N/A			
1	*Harness, Relay, (LCIT) 26P	G6295516			
2	*Harness, Relay, (LCIT) 4P	G6295515			
3	*Harness, Table, Power	G6295510			
4	*Harness, (LCIT) Feed Unit	G6295530			
5	*Harness, Table Feed Unit	G6295550			
6	*Harness, DPX	G6475590			
7	*Harness, Feed Motor 5P	G6475595			
8	*Harness, Feed Motor	G6475596			
9	*Harness, Relay OLCOT	G6475591			
	<p data-bbox="305 724 818 787">NOTE: ALL HARNESS LAYOUTS ARE SHOWN FOR REFERENCE ONLY.</p>				

FOR REFERENCE ONLY

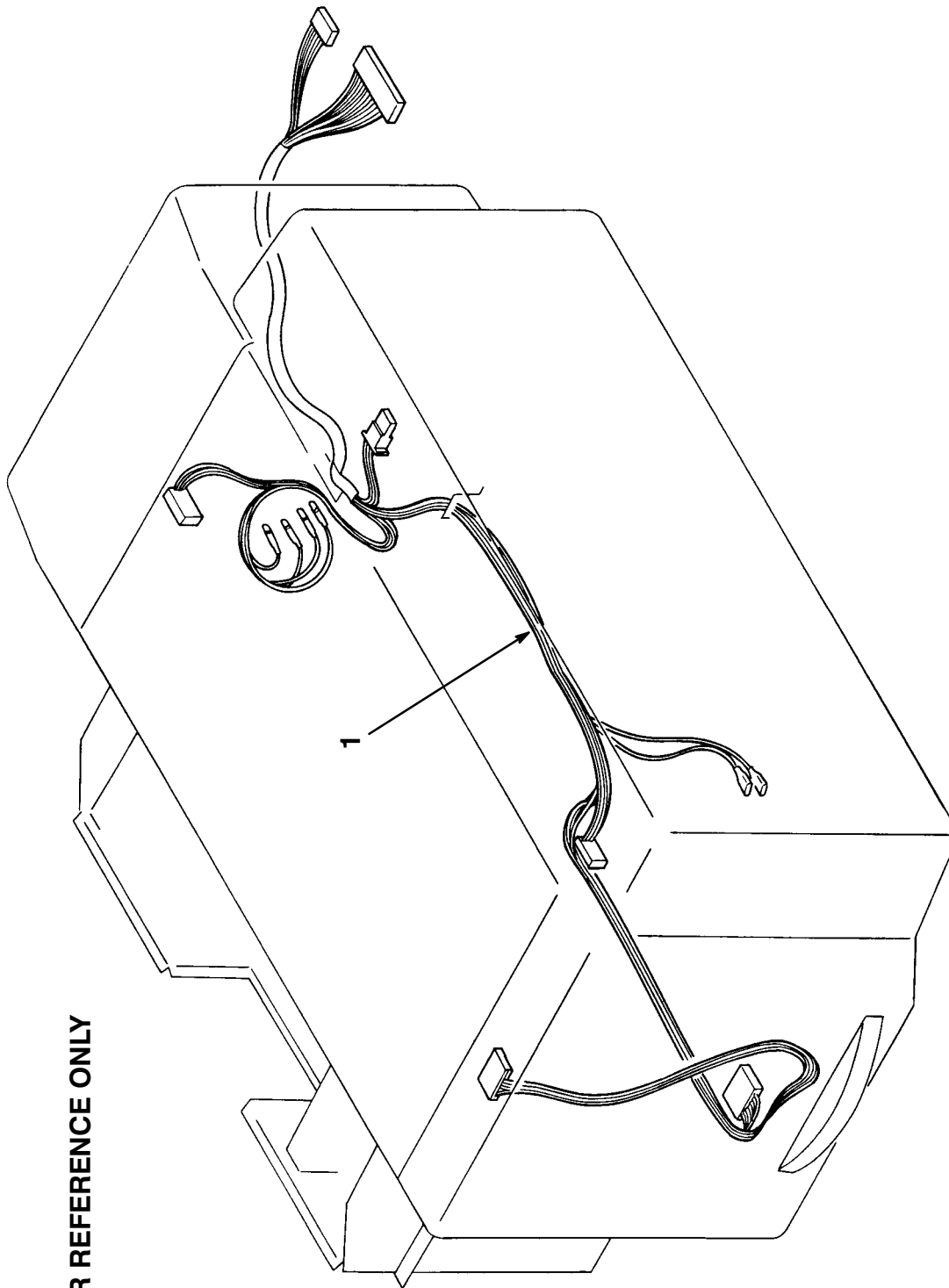

LPS32-19-SC

Figure 19. Harness Layout – Large Capacity Input Tray (LCIT)

FIG. & ITEM NO.	DESCRIPTION	VENDOR PART NO.	DEC PART NO.	USED ON CODE	REF FIG NO.
19– 1	<p>HARNESS LAYOUT – (LCIT)</p> <p>*Harness Assembly, (LCIT)</p> <p>NOTE: ALL HARNESS LAYOUTS ARE SHOWN FOR REFERENCE ONLY.</p>	<p>N/A</p> <p>G6305530</p>			

FOR REFERENCE ONLY

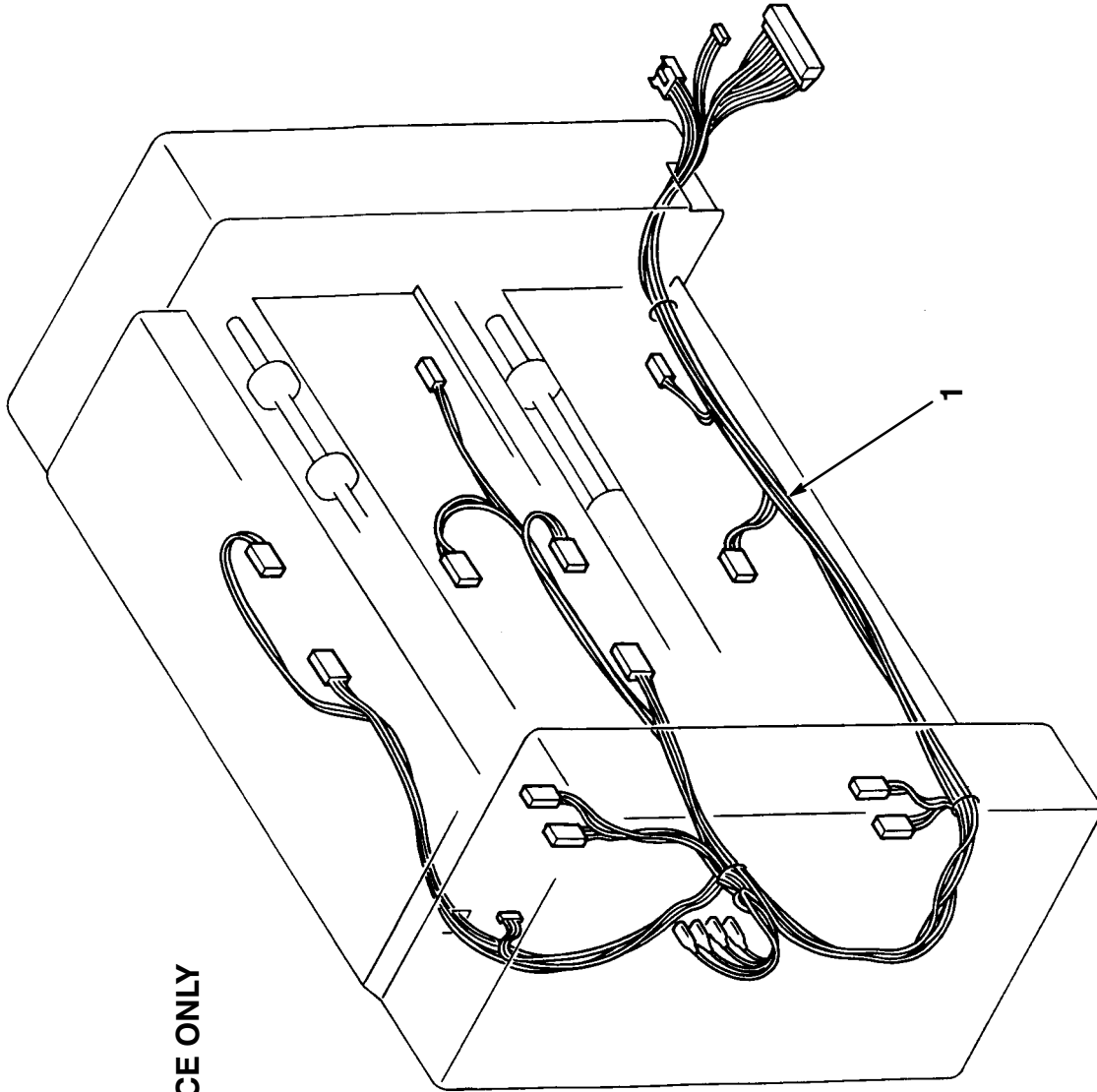

Figure 20. Harness Layout – Large Capacity Output Tray (LCOT)

FIG.& ITEM NO.	DESCRIPTION	VENDOR PART NO.	DEC PART NO.	USED ON CODE	REF FIG NO.
20-	HARNES LAYOUT – (LCOT)	N/A			12
1	*Harness, (LCOT)	G6465527			
	NOTE: ALL HARNES LAYOUTS ARE SHOWN FOR REFERENCE ONLY.				

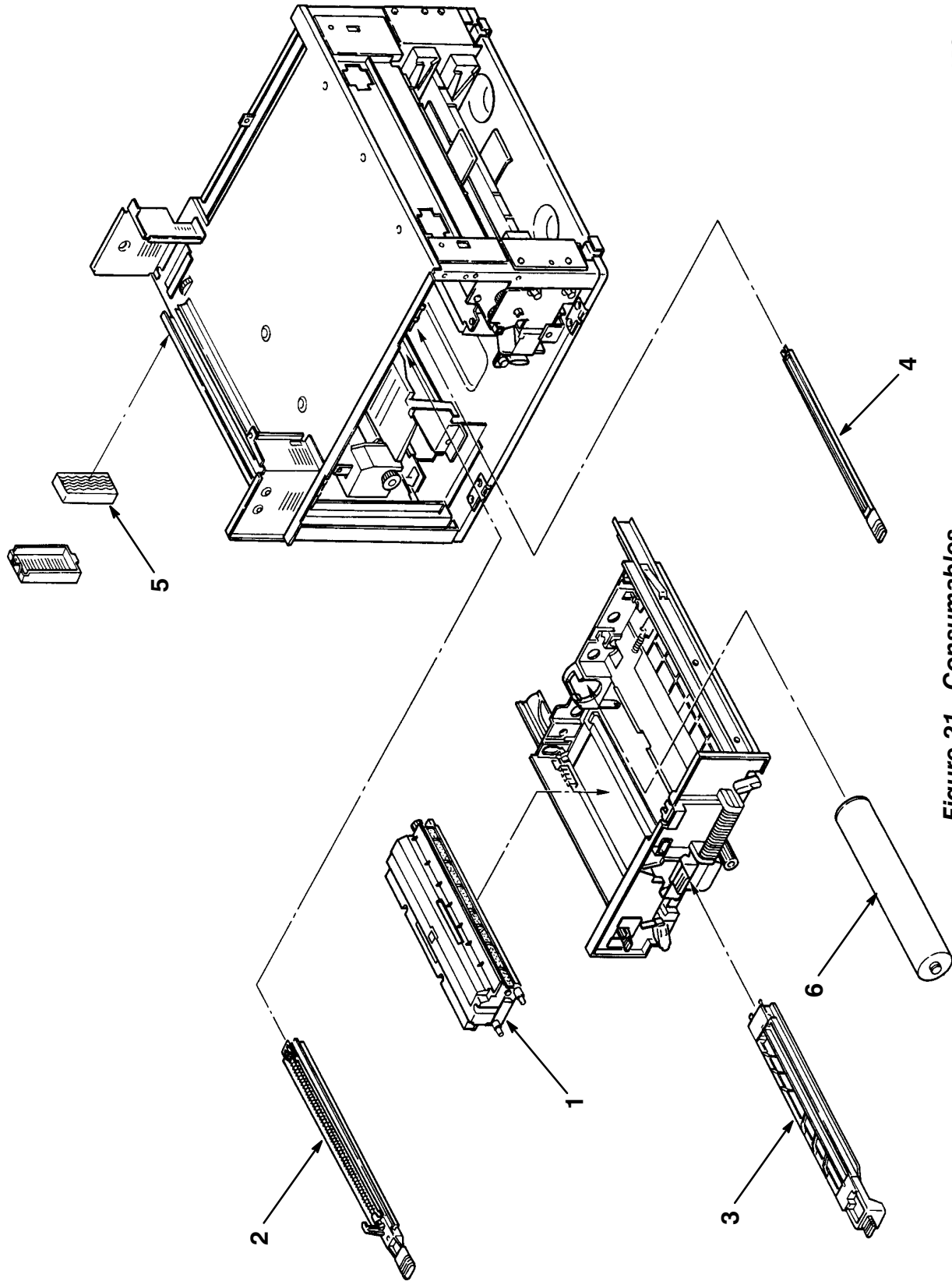

Figure 21. Consumables

FIG. & ITEM NO.	DESCRIPTION	VENDOR PART NO.	DEC PART NO.	USED ON CODE	REF FIG NO.
21-	CONSUMABLES (SEE NOTE 1)		N/A		1
1	*Cleaning Unit		29-30254-01		2
2	*Wire, Auto Main		29-30258-01		2
3	*Wire, T/S Charge		29-30252-01		2
4	*Plate, Shield		29-30259-01		2
5	*Filter, Ozone (100K)		29-30264-01		2
6	*Drum, OPC (SEE NOTE 2)	N/A			
	KITS (Not Shown)				
	KIT A – 15K Toner (2)		LPS3X-AA		
	KIT B – Cleaning Units (2)		LPSXX-AD		
	KIT C – OPC DRUM & SUPPLIES KIT, LPS32		LPS3X-AC		
	NOTE 1 : Items 2,3,4, 5 & 6 are included in the LPS32 OPC Drum & Supplies Kit, and should be replaced when the OPC Drum is replaced.				
	NOTE 2 : If OPC needs to be replaced before normal 100K maintenance, use the OPC Drum from the LPS20 OPC Drum Kit – Part Number LPS2X-AC or 29-27398-01.				

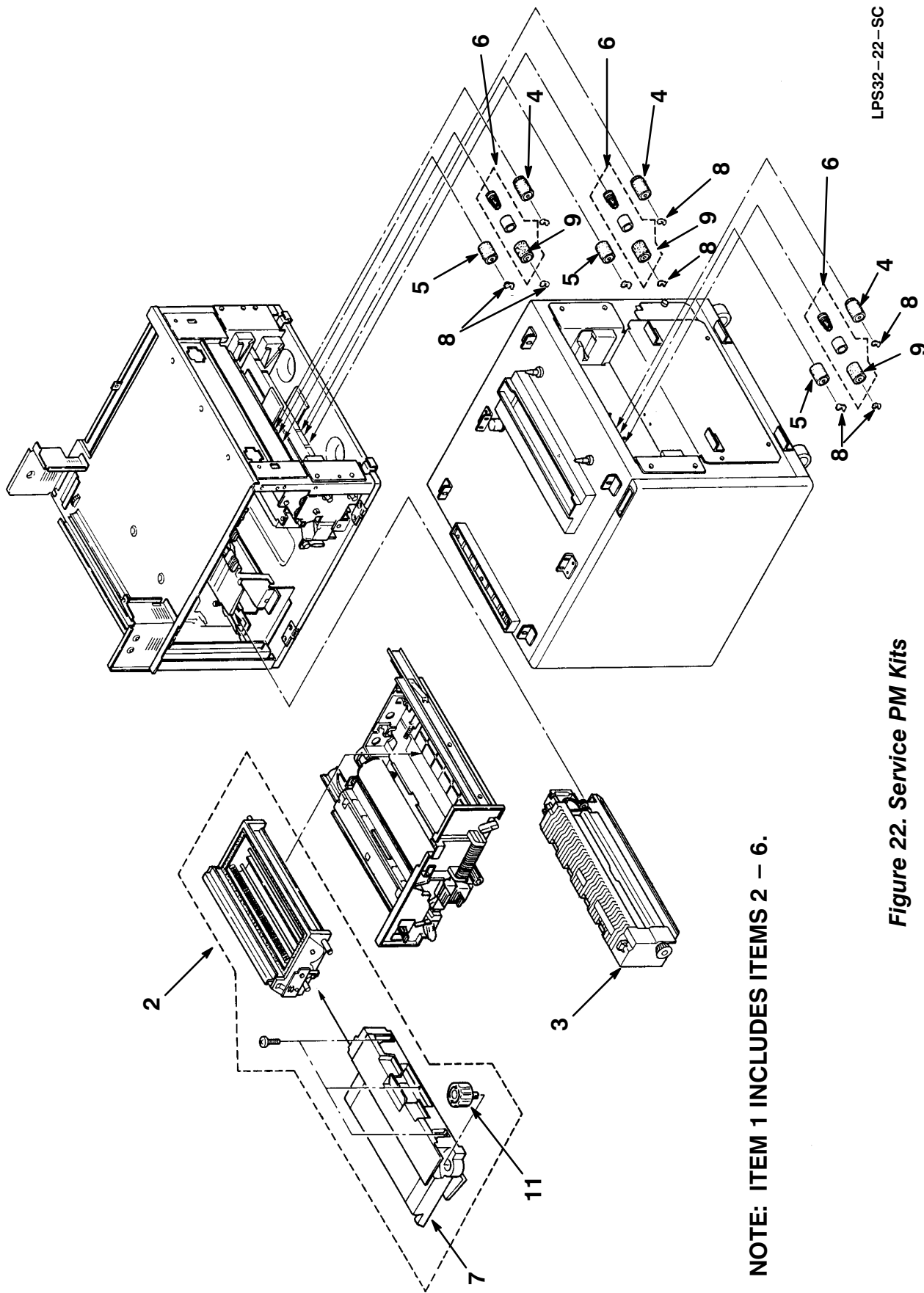

Figure 22. Service PM Kits

FIG.& ITEM NO.	DESCRIPTION	VENDOR PART NO.	DEC PART NO.	USED ON CODE	REF FIG NO.
22-	SERVICE PM KITS		N/A		2
1	*KIT, 320K SERVICE PM KIT (100V)		29-29655-01		
	*KIT, 320K SERVICE PM KIT (200V)		29-29656-01		
2	**Developer Unit		29-29635-01		2
3	**Fusing Unit (100V)		29-29637-01		2
	**Fusing Unit (200V)		29-29638-01		2
4	**Roller, Pick-Up		29-25103-00		
5	**Roller, Feed		29-25102-00		
6	**Roller Assembly, Separation		29-25104-00		
7	*Cover, Developer		29-30346-01		
8	*Ring, Snap	54472681			
9	*Roller, Separation		29-29653-01		
10	*FEED ROLLER KIT (See Note 2)		29-30302-01		
11	*Knob		29-30348-01		
101	*Screw, Phil Truss Hd M4 x 6	03440060D			
	NOTE 1: Item 1 includes Items 2-6.				
	NOTE 2: Item 10 includes one each of Item 4, Item 5 and Item 9.				
	NOTE 3: 2.4M Service PM requires replacement of Registration Roller - DEC P/N 29-30253-01 (See Figure 2) and replacement of Process Fan Unit - DEC P/N 29-29633-01 (See Figure 4).				

Ω

PART NUMBER/DESCRIPTION INDEX 

INDEX BY PART NUMBER
PrintServer 32 System

PART NO.	DESCRIPTION	FIG NO.	ITEM NO.
03130030B	Screw, Phl Pan Hd M3 x 3	11	106
03130040B	Screw, Phl Pan Hd M3 x 4	10	103
03130050B	Screw, Phl Pan Hd M3 x 5	11	101
03130050B	Screw, Phl Pan Hd M3 x 5	4	105
03130050B	Screw, Phl Pan Hd M3 x 5	8	101
03130080B	Screw, Phl Pan Hd M3 x 8	12B	103
03130080B	Screw, Phl Pan Hd M3 x 8	13	101
03130080B	Screw, Phl Pan Hd M3 x 8	16	2
03130300B	Screw, Phl Pan Hd M3 x 30	6	103
03140040B	Screw, Phl Pan Hd M4 x 4	14	102
03140040W	Screw, Phl Pan Hd M4 x 4	15	103
03140040W	Screw, Phl Pan Hd M4 x 4	6	104
03140060B	Screw, Phl Pan Hd M4 x 6	12B	104
03140060B	Screw, Phl Pan Hd M4 x 6	7	104
03140060B	Screw, Phl Pan Hd M4 x 6	5	102
03140060B	Screw, Phl Pan Hd M4 x 6	6	101
03140060B	Screw, Phl Pan Hd M4 x 6	15	101
03140060B	Screw, Phl Pan Hd M4 x 6	12A	102
03140060B	Screw, Phl Pan Hd M4 x 6	13	102
03140060B	Screw, Phl Pan Hd M4 x 6	9	101
03140060B	Screw, Phl Pan Hd M4 x 6	10	102
03140060B	Screw, Phl Pan Hd M4 x 6	11	102
03140060B	Screw, Phl Pan Hd M4 x 6	3	101
03140060B	Screw, Phl Pan Hd M4 x 6	4	104
03140100B	Screw, Phl Pan Hd M4 x 10	9	104
03140100B	Screw, Phl Pan Hd M4 x 10	10	101
03140100B	Screw, Phl Pan Hd M4 x 10	8	102
03230060B	Screw, Phl Sunk M3 x 6	9	103
03440060D	Screw, Phil Truss Hd M4 x 6	22	101
03440060F	Screw, Phl Truss Hd M4 x 6	3	103
03440060F	Screw, Phl Truss Hd M4 x 6	12A	103
03440080F	Screw, Phl Truss Hd M4 x 8	14	101
03440100F	Screw, Phl Pan Hd M4 X 10	4	103
05740050E	Screw, Hex Headless Set M4 x 5	15	102
05740050E	Screw, Hex Headless Set M4 x 5	7	101
07200025E	Ring, Retaining (M2.5)	10	105
07200030E	Ring, Retaining (M3)	13	103
07200040E	Ring, Retaining (M4)	12A	104
07200040E	Ring, Retaining M2.5	10	105
07200060E	Ring, Retaining (M6)	12A	101
07200060E	Ring, Retaining (M6)	9	102
08011135	Screw, Phl Pan Hd M3 x 3	11	103
08011185	Screw, Phl Truss Hd M4 x 8	2	102
08053368	Bearing, Ball (8 x 16 x 5MM)	7	103
09513005B	Screw, Phl Pan w/Flat Washer M3 x 5	12B	102
09513006B	Screw, Phl Hd w/Washer M3 x 6	3	102
09513020B	Screw, Phl Pan Hd w/Flat Washer 3 x 20	6	105
09513025B	Screw, Phl Pan Hd w/Flat Washer 3 x 25	6	106
09514006B	Screw, Phl Hd w/Flat Washer M4	4	102
09514006B	Screw, Phl Pan Hd w/Flat Washer M4	11	104
09514008B	Screw Phl Hd w/Flat Washer M4 x 8	10	104
09514008B	Screw, Phl Hd w/ Flat Washer M4 x 8	6	102
09514008B	Screw, Phl Hd w/Flat Washer M4 x 8	5	101

09514008B	Screw, Phi Hd w/Flat Washer M4 x 8	7	102
09514008B	Screw, Phi Hd w/Flat Washer M4 x 8	12A	105
09514008B	Screw, Phi Hd w/Flat Washer M4 x 8	4	106
09514008B	Screw, Phi Pan w/Flat Washer M4 x 8	12B	101
09654010B	Screw, Tapping M4 x 10	4	101
12-36097-01	Motor Assembly, Cassette	9	1
12-37037-01	Switch, Interlock (LCOT, Left Cover)	12A	4
12-37042-01	Timing Belt, (116XL)	9	2
12-37045-01	Belt, Timing (225MXL)	13	3
12-37049-01	Photoreflector	9	5
12-37052-01	Clutch, (TMO-F-01)	9	3
12-37052-02	Clutch, (TMO-F-03)	15	1
17-00198-14	Cord, Power (250V)	1	Not Shown
17-00199-21	Cord, Power (250V)	1	Not Shown
17-00209-15	Cord, Power (250V)	1	Not Shown
17-00210-13	Cord, Power (250V)	1	Not Shown
17-00310-08	Cord, Power (250V)	1	Not Shown
17-00457-16	Cord, Power (250V)	1	Not Shown
17-03218-01	Cable Assembly, (COAX Male - Female)	1	Not Shown
17-03381-01	Bracket Assembly, I/F Connector	5	4
17-03382-20	Receptacle, Main Charger	6	9
17-03382-21	Receptacle Assembly, T/S Charger	6	1
17-00364-18	Cord, Power (250V)	1	Not Shown
29-25102-00	Roller, Feed	22	5
29-25103-00	Roller, Pick-Up	22	4
29-25104-00	Roller Assembly, Separation	22	6
29-25526-00	Vacuum Cleaner (100V)	1	Not Shown
29-26017-00	Bags, Filter (Vacuum Cleaner)	1	Not Shown
29-26234-00	Kit, Cleaning	1	Not Shown
29-26259-00	Vacuum Cleaner (200V)	1	Not Shown
29-27358-01	FEED ASSEMBLY, TABLE	3	4
29-27358-01	FEED ASSEMBLY, TABLE	16	N/A
29-27362-01	Sensor Set, Cleaning Unit	6	2
29-27363-01	Switch, Left Cover Interlock	6	4
29-27365-01	Sensor Set, OPC Drum	6	6
29-27369-01	Switch, Toner Overflow	4	16
29-27373-01	Photo-Interrupter (EE-SX460-P2)	6	10
29-27374-01	Belt, Timing (166XL)	7	1
29-27380-01	Pulley, (32T)	7	2
29-27392-01	Tray, LCOT Upper Exit	12	5
29-27397-01	Photo-interrupter	10	1
29-27397-01	Photo-interrupter	9	6
29-27400-01	Solenoid Assembly, Drum Separation Pawl	6	11
29-27484-01	Fan Assembly, Controller	5	1
29-29625-01	Module, Mother Board	5	3
29-29626-01	Power Supply (100V)	2	5
29-29627-01	Power Supply (200V)	2	5
29-29628-01	DRIVE ASSEMBLY, MAIN	7	4
29-29629-01	Counter Unit, Total	6	3
29-29630-01	Motor Unit, Main	7	3
29-29631-01	OPTICAL ASSEMBLY	8	N/A
29-29631-01	OPTICAL ASSEMBLY	2	1
29-29632-01	FEED ASSEMBLY, PAPER (CASSETTE)	9	N/A

INDEX BY PART NUMBER

PrintServer 32 System

PART NO.	DESCRIPTION	FIG NO.	ITEM NO.
29-29632-01	FEED ASSEMBLY, PAPER (Cassette)	2	6
29-29633-01	Fan Unit, Process	4	15
29-29634-01	Motor, Wire Cleaning	6	16
29-29635-01	DEVELOPER UNIT	2	13
29-29635-01	Development Unit	22	2
29-29636-01	Drive Unit, Development	6	14
29-29637-01	FUSING ASSEMBLY (110V)	2	12
29-29637-01	FUSING ASSEMBLY (100V)	11	N/A
29-29637-01	Fusing Unit (100V)	22	3
29-29638-01	FUSING ASSEMBLY (220V)	2	12
29-29638-01	FUSING ASSEMBLY (200V)	11	N/A
29-29638-01	Fusing Unit (200V)	22	3
29-29639-01	GATE ASSEMBLY, PAPER FORK	10	N/A
29-29639-01	GATE ASSEMBLY, PAPER FORK	2	2
29-29640-01	Module, Engine Drive	5	2
29-29641-01	Panel Assembly, Operation (Control)	4	9
29-29642-01	Switch, Fusing Unit Interlock	6	8
29-29643-01	Transport Unit	2	3
29-29644-01	LCOT	12	1
29-29645-01	FEED ASSEMBLY, (LCIT)	3	2
29-29645-01	FEED ASSEMBLY, PAPER (LCIT)	15	N/A
29-29647-01	Module, Table Drive	3	1
29-29648-01	Led Unit, Quenching	2	4
29-29649-01	Motor, Fan (D06T-24TU)	6	7
29-29650-01	Power Pack	6	5
29-29651-01	Breaker, Circuit (W28XQ1A - 15, 15A)	2	11
29-29652-01	Breaker, Circuit (W28XQ1A - 8, 8A)	2	11
29-29653-01	Roller, Separation	22	9
29-29654-01	Pawl, Fusing Unit Separation	11	2
29-29655-01	KIT, 320K Service PM (110V)	2	Not Shown
29-29655-01	KIT, 320K SERVICE PM (100V)	22	1
29-29656-01	KIT, 320K Service PM (220V)	2	Not Shown
29-29656-01	KIT, 320K SERVICE PM (200V)	22	1
29-29657-01	Fan Motor Assembly, Development Cooling	6	12
29-29658-01	Solenoid, Cleaning Roller	6	15
29-30252-01	WIRE, T/S CHARGE	2	16
29-30252-01	Wire, T/S Charge	21	3
29-30253-01	Roller Unit, Registration	2	8
29-30254-01	CLEANING UNIT	2	15
29-30254-01	Cleaning Unit	21	1
29-30255-01	Drawer Unit	2	7
29-30256-01	Wire Assembly, T/S	2	9
29-30257-01	Cap Assembly, Registration	2	10
29-30258-01	Wire, Auto Main	2	14
29-30258-01	Wire, Auto Main	21	2
29-30259-01	Plate, Shield	2	18
29-30259-01	Plate, Shield	21	4
29-30260-01	Panel, Operation (LCIT)	14	3
29-30261-01	Cover, Top (LCIT)	14	5
29-30262-01	Door Assembly, Table	3	6
29-30263-01	Hinge, Table Door	3	7
29-30264-01	Filter, Ozone (100K)	21	5
29-30264-01	Filter, Ozone (100K)	4	20
29-30265-01	Cover, Front	4	14

29-30266-01	Diode, Main Charger Zener	4	17
29-30267-01	Tray, Stacking	12	7
29-30267-01	Tray, Stacking	4	18
29-30268-01	Spring, Lower Tray	4	19
29-30270-01	Spring, Feeler Drum Change Sensor	7	7
29-30273-01	Belt, Timing (256MXL)	10	2
29-30274-01	Solenoid Assembly, Fork Gate	10	3
29-30275-01	Photo-interruptor, Fusing Exit	10	4
29-30276-01	Lamp, Fusing (100V)	11	1
29-30277-01	Lamp, Fusing (200V)	11	1
29-30278-01	Thermistor and Fuse Assembly	11	3
29-30282-01	Spring, Tray Upper	12	8
29-30283-01	Belt, Timing (271MXL)	12A	1
29-30284-01	Solenoid Assembly, LCOT	12A	5
29-30285-01	Stay Assembly, Job Separation (LCOT)	12A	6
29-30286-01	Belt, Timing (194XL)	12A	7
29-30287-01	Photoreflector	16	1
29-30287-01	Photoreflector (GP2A10)	12B	1
29-30287-01	Photoreflector (GP2A10)	13	1
29-30288-01	Motor Assembly, Exit Drive (LCOT)	12B	2
29-30289-01	Photosensor w/Actuator	13	7
29-30290-01	Solenoid Asembly, DPX	13	2
29-30291-01	Belt, Timing (140MXL)	13	4
29-30292-01	Motor Assembly, DPX Feed	13	5
29-30293-01	Module, Feed Motor Driver	15	4
29-30294-01	Cover, Rear (LCIT)	14	1
29-30295-01	Cover, Right (LCIT)	14	2
29-30296-01	Cover, Front (LCIT)	14	3
29-30297-01	Photosensor w/Actuator	13	6
29-30298-01	Guide Assembly, DPX Transport	13	8
29-30300-01	Motor Assembly, Table Feed	15	2
29-30301-01	Solenoid Assembly, (LCIT FEED)	15	3
29-30302-01	FEED ROLLER KIT	22	10
29-30346-01	Cover , Developer	22	7
29-30347-01	Stay Assembly, Upper (Feeler Exit) (LCOT)	12B	3
29-30348-01	Knob	22	11
29-30349-01	Kit, OPC Reset Feeler	7	10
29-30524-01	Tool, T/S Charger (LPS32)	3	3
30-39034-01	Engine, Print (100-120V)	1	Not Shown
30-39034-02	Engine, Print (200-240V)	1	Not Shown
30-39034-03	Engine, Print (100-120V)	1	Not Shown
30-39034-04	Engine, Print (200-240V)	1	Not Shown
30-39034-05	LCIT, LARGE CAPACITY INPUT TRAY (w/7 trays) LPS3X-BA	1	8
30-39034-05	LCIT, LARGE CAPACITY INPUT TRAY (w/7 trays) LPS3X-BA	14	N/A
30-39034-06	DPX ASSEMBLY, DUPLEXER LPS3X-DA	13	N/A
30-39034-07	Kit A, Shipaway	1	Not Shown
30-39034-08	Kit B, Shipaway	1	Not Shown
30-39034-09	Kit B, Shipaway	1	Not Shown
36-28231-02	Label, Direct Thermal 1.62 x 6	1	Not Shown
36-30422-07	Label, Postcard FTZ	1	Not Shown
36-30689-13	Label, Product Conversion (XA-A2)	1	Not Shown
36-30689-14	Label, Product Conversion (XA-C7)	1	Not Shown

INDEX BY PART NUMBER
PrintServer 32 System

PART NO.	DESCRIPTION	FIG NO.	ITEM NO.
36-30689-15	Label, Product Conversion (XC-B2)	1	Not Shown
36-30689-16	Label, Product Conversion (XC-C8)	1	Not Shown
36-30689-17	Label, Product Conversion (XB-A3)	1	Not Shown
36-30689-18	Label, Product Conversion (XD-B3)	1	Not Shown
36-30689-19	Label, Product Conversion (XB-A3)	1	Not Shown
36-30689-20	Label, Product Conversion (XD-B3)	1	Not Shown
36-37522-02	Label, Serial Number, Artwork	1	Not Shown
36-37959-02	Label, LPS32 OCP (French)	1	Not Shown
36-37959-03	Label, LPS32 OCP (German)	1	Not Shown
36-37959-04	Label, LPS32 OCP (Dutch)	1	Not Shown
36-37959-05	Label, LPS32 OCP (Italian)	1	Not Shown
36-38723-02	Label, Jam Clearance (French)	1	Not Shown
36-38723-04	Label, Jam Clearance (German)	1	Not Shown
36-38723-05	Label, Jam Clearance (Dutch)	1	Not Shown
36-38723-06	Label, Jam Clearance (Italian)	1	Not Shown
52052697	Bushing, Upper Registration Roller	10	28
54-20734-01	Module, TURBO Memory	1	6
54-20734-01	Module, TURBO Memory	5	9
54-20830-03	Module, TURBO Controller	1	5
54-20830-03	Module, TURBO Controller	5	8
54195714	Screw, Stepped M4	11	105
54472681	Ring, Snap	2	101
54472681	Ring, Snap	22	8
58402416	Bushing, Pinch Roller	10	26
74-36751-03	Medallion, Front Panel (PrintServer 32)	1	7
AA143076	Screw, Stepped M4	10	33
EK-LPS32-DK	Documentation, PrintServer 32 Customer	1	Not Shown
EK-LPS32-FG	Card, Read Me First	1	Not Shown
EK-LPS32-SG	Documentation, PrintServer 32 Service Guide	1	Not Shown
EK-LPSG2-OG	Documentation, Operator's Guide (German)	1	Not Shown
EK-LPSH2-OG	Documentation, Operator's Guide (Dutch)	1	Not Shown
EK-LPSP2-OG	Documentation, Operator's Guide (French)	1	Not Shown
EK-LPSU2-OG	Documentation, Operator's Guide (Italian)	1	Not Shown
EK-PRNTR-VD	Video, PrintServer 32 User Maintenance	1	Not Shown
G0041357	Bracket, Main Fan	6	13
G0041610	Cover, Operation Panel	4	10
G0041638	Pivot, Left Corner	4	7
G0041640	Holder, Ozone Cartridge	4	2
G0041649	Cover, Top	4	3
G0041663	Cover, Inner Upper Right	4	13
G0041664	Cover, Inner Lower Right	4	12
G0041671	Cover Assembly, Left	4	6
G0041675	Tray, Side Exit	4	5
G0041680	Cover, Rear	4	4
G0045400	Module, Paper Feed Unit	9	4
G0045542	Harness, Relay, Paper Feed Unit	17	2
G0045544	Harness, Paper Feed Unit	17	10
G0045554	Harness, Relay, Process Unit	17	3
G0045580	Harness, Relay, Operation Panel	17	1
G0046951	Interrupter, Side Exit Overflow	10	31
G0131016	Cover, Inner Left	4	11

G0131020	Cartridge, Ozone Filter	4	1
G0131447	Screw, Fusing Stopper Thumb	2	21
G0131448	Strap, Thumb Screw	2	22
G0131551	Cover, Right	4	8
G0134251	Spring, Drum Change Feeler Pressure	7	9
G0134616	Cover, Fusing	11	4
G0134811	Spring, Fork Gate	10	23
G0134814	Spring, Overflow Feeler	10	5
G0134834	Roller, Fork Gate Bottom Drive	10	14
G0134836	Roller, Fork Gate Drive Entrance	10	24
G0134838	Roller, Fork Gate Entrance Idle	10	17
G0134846	Fork Gate, Lower	10	21
G0134870	Lever, Fork Gate	10	25
G0134874	Tightener Assembly – 1	10	29
G0134896	Fork Gate, Upper	10	20
G0134881	Bracket, Side Exit Feeler	10	32
G0134883	Bracket, Fork Gate Upper	10	27
G0134886	Feeler, Side Exit Overflow	10	30
G0135520	Harness, Communication, Table	17	8
G0135530	Harness, Relay, Optical Unit	17	7
G0135540	Harness, Relay, PSU	17	5
G0135547	Harness, Development Fan Relay	17	12
G0135560	Harness, Feed Drive	17	4
G0135564	Harness, Left Side	17	6
G0135566	Harness, Fork Gate Unit	17	11
G6274856	Cover, Lower Right (LCOT)	12A	3
G6274868	Cover, Upper Right (LCOT)	12A	2
G6295510	Harness, Table, Power	18	3
G6295515	Harness, Relay, (LCIT) 4P	18	2
G6295516	Harness, Relay, (LCIT) 26P	18	1
G6295530	Harness, (LCIT) Feed Unit	18	4
G6295550	Harness, Table Feed Unit	18	5
G6305530	Harness Assembly, (LCIT)	19	1
G6461530	Cover, LCOT Front	12	4
G6461531	Cover, LCOT Rear	12	2
G6461532	Cover, LCOT Top	12	6
G6464931	Cover, LCOT Left	12	3
G6465527	Harness, (LCOT)	20	1
G6475590	Harness, DPX	18	6
G6475591	Harness, Relay OLCOT	18	9
G6475595	Harness, Feed Motor 5P	18	7
G6475596	Harness, Feed Motor	18	8
GA063013	Spring, 100GF	10	6
GA080002	Bushing 6mm	10	34
GA080004	Bushing, 6mm	10	7
GA120006	Brush, Antistatic Fusing Exit	10	22
GA134003	Pulley, Idler (11.2mm)	10	8
GB013045	Gear, Drive Fork Gate	10	13
GB013046	Gear, Fork Gate Relay	10	9
GB017030	Gear, Pulley, Fork Gate	10	11
GB030028	Pulley, OPC Drive	7	5
GB030029	Pulley, MXL33	10	12
GB033002	Pulley, Fork Gate One Way	10	10
GD015001	Shaft, Drive, OPC Drum	7	8

INDEX BY PART NUMBER

PrintServer 32 System

PART NO.	DESCRIPTION	FIG NO.	ITEM NO.
GF020021	Roller, Fork Gate Drive	10	16
GF022002	Roller, Idle - 2	10	15
GF022005	Roller, Fork Gate Idle Side Exit	10	18
GF023003	Roller, Fork Gate Drive Side Exit	10	19
GW030001	Cable Optical Fiber, 600MM	17	9
LPS32-A2	LPS32-A2 (Simplex) (120V)	1	N/A
LPS32-A3	LPS32-A3 (Simplex) (240V)	1	N/A
LPS32-B2	LPS32-B2 (Duplex) (120V)	1	N/A
LPS32-B3	LPS32-B3 (Duplex) (240V)	1	N/A
LPS32-C7	LPS32-C7 (Simplex w Mem) (120V)	1	N/A
LPS32-C8	LPS32-C8 (Duplex w Mem) (240V)	1	N/A
LPS32-XA	LPS32-XA (Simplex) (120V)	1	N/A
LPS32-XB	LPS32-XB (Simplex) (240V)	1	N/A
LPS32-XC	LPS32-XC (Duplex) (120V)	1	N/A
LPS32-XD	LPS32-XD (Duplex) (240V)	1	N/A
LPS32-XA	ENGINE, SIMPLEX (No Controller)	1	1
LPS32-XB	ENGINE, SIMPLEX (No Controller)	1	2
LPS32-XC	ENGINE, DUPLEX (No Controller)	1	3
LPS32-XD	ENGINE, DUPLEX (No Controller)	1	4
LPS3K-AB	KIT, COUNTRY (Belguim,France, Germ., Holland)	1	Not Shown
LPS3K-AD	KIT, COUNTRY (Denmark)	1	Not Shown
LPS3K-AE	KIT, COUNTRY (UK/Ireland)	1	Not Shown
LPS3K-AF	KIT, COUNTRY (Finland, Norway, Portugal, Sweden)	1	Not Shown
LPS3K-AI	KIT, COUNTRY (Italian)	1	Not Shown
LPS3K-AK	KIT, COUNTRY (Switzerland)	1	Not Shown
LPS3K-AS	KIT, COUNTRY (Spain)	1	Not Shown
LPS3K-AT	KIT, COUNTRY (Israel)	1	Not Shown
LPS3K-AZ	KIT, COUNTRY (Australia/New Zealand)	1	Not Shown
LPS3X-AA	KIT A - 2 - 25K Toner	21	Not Shown
LPS3X-AC	KIT C - Supplies	21	Not Shown
LPS3X-BA	LCIT, LARGE CAPACITY INPUT TRAY (w/7 trays) (30-39034-05)	1	8
LPS3X-BA	LCIT, LARGE CAPACITY INPUT TRAY (w/7 trays) (30-39034-05)	14	N/A
LPS3X-DA	DPX ASSEMBLY, DUPLEXER (30-39034-06)	13	N/A
LPS3X-LA	Kit 1 (A4/Letter)	14	Not Shown
LPS3X-LB	Kit 2 (5 Trays)	14	Not Shown
LPS3X-LC	Kit 3 (7 Trays)	14	Not Shown
LPS4X-BA	Cassette, Paper: SCIT (Small)	2	19
LPS4X-BB	Cassette, Paper: SCIT (Large)	2	20
LPSXX-AD	KT B - Cleaning Unit Etc	21	Not Shown

THIS PAGE INTENTIONALLY LEFT BLANK.

INDEX BY PART DESCRIPTION
PrintServer 32 System

DESCRIPTION	PART NO.	FIG. NO.	ITEM NO.
Bags, Filter (Vacuum Cleaner)	29-26017-00	1	Not Shown
Bearing, Ball (8 x 16 x 5MM)	08053368	7	103
Belt, Timing (166XL)	29-27374-01	7	1
Belt, Timing (140MXL)	29-30291-01	13	4
Belt, Timing (194XL)	29-30286-01	12A	7
Belt, Timing (225MXL)	12-37045-01	13	3
Belt, Timing (256MXL)	29-30273-01	10	2
Belt, Timing (271MXL)	29-30283-01	12A	1
Bracket, Module	N/A	5	6
Bracket, Mother Board	N/A	5	7
Bracket Assembly, I/F Connector	17-03381-01	5	4
Bracket, Fork Gate Upper	G0134883	10	27
Bracket, Main Fan	G0041357	6	13
Bracket, Side Exit Feeler	G0134881	10	32
Breaker, Circuit (W28XQ1A - 15, 15A)	29-29651-01	2	11
Breaker, Circuit (W28XQ1A - 8, 8A)	29-29652-01	2	11
Brush, Antistatic Fusing Exit	GA120006	10	22
Bushing 6mm	GA080002	10	34
Bushing, 6mm	GA080004	10	7
Bushing, 8 x 10 x 6MM	N/A	7	105
Bushing, Pinch Roller	58402416	10	26
Bushing, Upper Registration Roller	52052697	10	28
Cable Assembly, (COAX Male - Female)	17-03218-01		
Cable Optical Fiber, 600MM	GW030001	17	9
Cap Assembly, Registration	29-30257-01	2	10
Card, Read Me First	EK-LPS32-FC	1	Not Shown
Cartridge, Ozone Filter	G0131020	4	1
Cassette, Paper: SCIT (Large)	LPS4X-BB	2	20
Cassette, Paper: SCIT (Small)	LPS4X-BA	2	19
CLEANING UNIT	29-30254-01	2	15
Cleaning Unit	29-30254-01	21	1
Clutch, Registration	N/A	7	4A
Clutch, (TMO-F-01)	12-37052-01	9	3
Clutch, (TMO-F-03)	12-37052-02	15	1
CONSUMABLES	N/A	21	N/A
Cord, Power (250V)	17-00198-14	1	Not Shown
Cord, Power (250V)	17-00310-08	1	Not Shown
Cord, Power (250V)	17-00209-15	1	Not Shown
Cord, Power (250V)	17-00199-21	1	Not Shown
Cord, Power (250V)	17-00364-18	1	Not Shown
Cord, Power (250V)	17-00210-13	1	Not Shown
Cord, Power (250V)	17-00457-16	1	Not Shown
Counter Unit, Total	29-29629-01	6	3
Cover Assembly, Left	G0041671	4	6
Cover, Developer	29-30346-01	22	7
Cover, Front	29-30265-01	4	14
Cover, Front (LCIT)	29-30296-01	14	3
Cover, Fusing	G0134616	11	4
Cover, Inner Left	G0131016	4	11
Cover, Inner Lower Right	G0041664	4	12
Cover, Inner Upper Right	G0041663	4	13
Cover, LCOT Front	G6461530	12	4
Cover, LCOT Left	G6464931	12	3

INDEX BY PART DESCRIPTION

PrintServer 32 System

DESCRIPTION	PART NO.	FIG. NO.	ITEM NO.
Cover, LCOT Rear	G6461531	12	2
Cover, LCOT Top	G6461532	12	6
Cover, Lower Right (LCOT)	G6274856	12A	3
Cover, Operation Panel	G0041610	4	10
Cover, PCB Rack	N/A	5	5
Cover, Rear	G0041680	4	4
Cover, Rear (LCIT)	29-30294-01	14	1
Cover, Right	G0131551	4	8
Cover, Right (LCIT)	29-30295-01	14	2
Cover, Top	G0041649	4	3
Cover, Top (LCIT)	29-30261-01	14	5
Cover, Upper Right (LCOT)	G6274868	12A	2
DEVELOPER UNIT	29-29635-01	2	13
Development Unit	29-29635-01	22	2
Diode Assembly, Laser	N/A	8	3
Diode, Main Charger Zener	29-30266-01	4	17
Documentation, Operator's Guide (Dutch)	EK-LPSH2-OG	1	Not Shown
Documentation, Operator's Guide (French)	EK-LPSP2-OG	1	Not Shown
Documentation, Operator's Guide (Germ.)	EK-LPSG2-OG	1	Not Shown
Documentation, Operator's Guide (Italian)	EK-LPSU2-OG	1	Not Shown
Documentation, Operator's Guide (Spanish)	EK-LPSS2-OG	1	Not Shown
Documentation, PrintServer 32 Customer	EK-LPS32-DK	1	Not Shown
Documentation, PrintServer 32 Service Guide	EK-LPS32-SG	1	Not Shown
Door Assembly, Table	29-30262-01	3	6
Drawer Unit	29-30255-01	2	7
DRIVE ASSEMBLY, MAIN	N/A	7	N/A
DRIVE UNIT, MAIN	29-29628-01	7	4
Drive Unit, Development	29-29636-01	6	14
Drum, OPC	N/A	2	17
DUPLEXER ASSEMBLY (30-39034-06)	LPS3X-DA	13	N/A
ELECTRICAL ASSEMBLY	N/A	6	N/A
ENGINE, DUPLEX (No Controller) (120V)	LPS32-XC	1	3
ENGINE, DUPLEX (No Controller) (240V)	LPS32-XD	1	4
Engine, Print (100-120V)	30-39034-01	1	N/A
Engine, Print (200-240V)	30-39034-02	1	N/A
Engine, Print (100-120V)	30-39034-03	1	N/A
Engine, Print (200-240V)	30-39034-04	1	N/A
ENGINE, SIMPLEX (No Controller)	LPS32-XA	1	1
ENGINE, SIMPLEX (No Controller)	LPS32-XB	1	2
EXTERIOR, LPS32	N/A	4	N/A
Fan Assembly, Controller	29-27484-01	5	1
Fan Unit, Process	29-29633-01	4	15
Fan Motor Assembly, Development Cooling	29-29657-01	6	12
FEED ASSEMBLY, PAPER (CASSETTE)	29-29632-01	9	N/A
FEED ROLLER KIT	29-30302-01	22	10
FEED ASSEMBLY, PAPER (LCIT)	29-29645-01	3	2
FEED ASSEMBLY, PAPER (LCIT)	29-29645-01	15	N/A
FEED ASSEMBLY, PAPER (Cassette)	29-29632-01	2	6
FEED ASSEMBLY, TABLE	29-27358-01	16	N/A
FEED ASSEMBLY, TABLE	29-27358-01	3	4
Feeler, Drum Change Sensor	N/A	7	6
Feeler, Side Exit Overflow	G0134886	10	30
Filter, Ozone (100K)	29-30264-01	21	5

INDEX BY PART DESCRIPTION
PrintServer 32 System

DESCRIPTION	PART NO.	FIG. NO.	ITEM NO.
Filter, Ozone (100K)	29-30264-01	4	20
Fork Gate, Lower	G0134846	10	21
Fork Gate, Upper	G0134896	10	20
FUSING UNIT (110V)	29-29637-01	2	12
FUSING ASSEMBLY (100V)	29-29637-01	11	N/A
Fusing Unit (100V)	29-29637-01	22	3
Fusing Unit (200V)	29-29638-01	22	3
FUSING UNIT (220V)	29-29638-01	2	12
FUSING ASSEMBLY (200V)	29-29638-01	11	N/A
GATE ASSEMBLY, PAPER FORK	29-29639-01	10	N/A
GATE ASSEMBLY, PAPER FORK	29-29639-01	2	2
Gear, Drive Fork Gate	GB013045	10	13
Gear, Fork Gate Relay	GB013046	10	9
Gear, Pulley, Fork Gate	GB017030	10	11
Guide Assembly, DPX Transport	29-30298-01	13	8
Harness Assembly, (LCIT)	G6305530	19	1
HARNESS LAYOUT - (LCIT)	N/A	19	N/A
HARNESS LAYOUT - (LCOT)	N/A	20	N/A
HARNESS LAYOUT - REAR VIEW	N/A	17	N/A
HARNESS LAYOUT - TABLE	N/A	18	N/A
Harness, (LCIT) Feed Unit	G6295530	18	4
Harness, (LCOT)	G6465527	20	1
Harness, Communication, Table	G0135520	17	8
Harness, DPX	G6475590	18	6
Harness, Development Fan Relay	G0135547	17	12
Harness, Feed Drive	G0135560	17	4
Harness, Feed Motor	G6475596	18	8
Harness, Feed Motor 5P	G6475595	18	7
Harness, Fork Gate Unit	G0135566	17	11
Harness, Left Side	G0135564	17	6
Harness, Paper Feed Unit	G0045544	17	10
Harness, Relay, (LCIT) 26P	G6295516	18	1
Harness, Relay, (LCIT) 4P	G6295515	18	2
Harness, Relay OLCOT	G6475591	18	9
Harness, Relay, Operation Panel	G0045580	17	1
Harness, Relay, Optical Unit	G0135530	17	7
Harness, Relay, PSU	G0135540	17	5
Harness, Relay, Paper Feed Unit	G0045542	17	2
Harness, Relay, Process Unit	G0045554	17	3
Harness, Table Feed Unit	G6295550	18	5
Harness, Table, Power	G6295510	18	3
Hinge, Table Door	29-30263-01	3	7
Holder, Ozone Cartridge	G0041640	4	2
Interrupter, Side Exit Overflow	G0046951	10	31
Kit A - 15K Toner (2)	LPS3X-AA	21	Not Shown
Kit A - Shipaway	30-39034-07	1	N/A
Kit B - Cleaning Units (2)	LPSXX-AD	21	Not Shown
Kit B - Shipaway	30-39034-08	1	N/A
Kit B - Shipaway	30-39034-09	1	N/A
Kit C - OPC Drum & Supplies, LPS32	LPS3X-AC	21	N/A
KITS, SERVICE PM	N/A	22	N/A
KIT, 320K Service PM (220V)	29-29656-01	2	Not Shown

INDEX BY PART DESCRIPTION

PrintServer 32 System

DESCRIPTION	PART NO.	FIG. NO.	ITEM NO.
KIT, 320K Service PM (110V)	29-29655-01	2	Not Shown
Kit 1, LCIT (A4/Letter)	LPS3X-LA	14	Not Shown
Kit 2, LCIT (5 Trays)	LPS3X-LB	14	Not Shown
Kit 3, LCIT (7 Trays)	LPS3X-LC	14	Not Shown
Kit, Cleaning	29-26234-00	1	Not Shown
Kit, OPC Reset Feeler	29-30349-01	7	10
KIT, COUNTRY (Australia/New Zealand)	LPS3K-AZ	1	Not Shown
KIT, COUNTRY (Belgium, France, Germ. ,Holland)	LPS3K-AB	1	Not Shown
KIT, COUNTRY (UK, Ireland)	LPS3K-AE	1	Not Shown
KIT, COUNTRY (Denmark)	LPS3K-AD	1	Not Shown
KIT, COUNTRY (Finland, Norway, Portugal, Sweden)	LPS3K-AF	1	Not Shown
KIT, COUNTRY (Israel)	LPS3K-AT	1	Not Shown
KIT, COUNTRY (Italian)	LPS3K-AI	1	Not Shown
KIT, COUNTRY (Spain)	LPS3K-AS	1	Not Shown
KIT, COUNTRY (Switzerland)	LPS3K-AK	1	Not Shown
KIT, SERVICE PM (100V)	29-29655-01	22	1
KIT, SERVICE PM (200V)	29-29656-01	22	1
Knob	29-30348-01	22	11
Label, Direct Thermal 1.62 x 6	36-28231-02	1	Not Shown
Label, Jam Clearance (Dutch)	36-38723-05	1	Not Shown
Label, Jam Clearance (French)	36-38723-02	1	Not Shown
Label, Jam Clearance (German)	36-38723-04	1	Not Shown
Label, Jam Clearance (Italian)	36-38723-06	1	Not Shown
Label, Jam Clearance (Spanish)	36-38723-03	1	Not Shown
Label, LPS32 OPC (Dutch)	36-37959-04	1	Not Shown
Label, LPS32 OPC (French)	36-37959-02	1	Not Shown
Label, LPS32 OPC (German)	36-37959-03	1	Not Shown
Label, LPS32 OPC (Italian)	36-37959-05	1	Not Shown
Label, LPS32 OPC (Spanish)	36-37959-07	1	Not Shown
Label, Postcard FTZ	36-30422-07	1	Not Shown
Label, Product Conversion (XA-A2)	36-30689-13	1	Not Shown
Label, Product Conversion (XA-C7)	36-30689-14	1	Not Shown
Label, Product Conversion (XC-B2)	36-30689-15	1	Not Shown
Label, Product Conversion (XC-C8)	36-30689-16	1	Not Shown
Label, Product Conversion (XB-A3)	36-30689-17	1	Not Shown
Label, Product Conversion (XD-B3)	36-30689-18	1	Not Shown
Label, Serial Number VLC, Artwork	36-37522-02	1	Not Shown
Lamp, Fusing (100V)	29-30276-01	11	1
Lamp, Fusing (200V)	29-30277-01	11	1
LCIT, LARGE CAPACITY INPUT TRAY (w/7 trays) (30-39034-05)	LPS3X-BA	1	8
LCIT, LARGE CAPACITY INPUT TRAY (w/7 trays) (30-39034-05)	LPS3X-BA	14	N/A
LCOT	29-29644-01	12	1
Led Unit, Quenching	29-29648-01	2	4
Lever, Fork Gate	G0134870	10	25
LPS32-A2 (Simplex) (120V)	LPS32-A2	1	N/A
LPS32-A3 (Simplex) (240V)	LPS32-A3	1	N/A
LPS32-B2 (Duplex) (120V)	LPS32-B2	1	N/A
LPS32-B3 (Dulexc) (240V)	LPS32-B3	1	N/A
LPS32-C7 (Simplex w Mem) (120V)	LPS32-C7	1	N/A
LPS32-C8 (Duplex w Mem) (240V)	LPS32-C8	1	N/A

INDEX BY PART DESCRIPTION
PrintServer 32 System

DESCRIPTION	PART NO.	FIG. NO.	ITEM NO.
LPS32-XA (Simplex) (120V)	LPS32-XA	1	N/A
LPS32-XB (Simplex) (240V)	LPS32-XB	1	N/A
LPS32-XC (Duplex) (120V)	LPS32-XC	1	N/A
LPS32-XD (Duplex) (240V)	LPS32-XD	1	N/A
Medallion, Front Panel (PrintServer 32)	74-36751-03	1	8
Module, Engine Drive	29-29640-01	5	2
Module, Feed Motor Driver	29-30293-01	15	4
Module, Mother Board	29-29625-01	5	3
Module, Paper Feed Unit	G0045400	9	4
Module, Scanner Motor Drive	N/A	8	1
Module, TURBO Controller	54-20830-03	1	5
Module, TURBO Controller	54-20830-03	5	8
Module, TURBO Memory	54-20734-01	1	6
Module, TURBO Memory	54-20734-01	5	9
Module, Table Drive	29-29647-01	3	1
Motor Assembly, Cassette	12-36097-01	9	1
Motor Assembly, DPX Feed	29-30292-01	13	5
Motor Assembly, Exit Drive (LCOT)	29-30288-01	12B	2
Motor Unit, Main	29-29630-01	7	3
Motor Assembly, Table Feed	29-30300-01	15	2
Motor, Fan (D06T-24TU)	29-29649-01	6	7
Motor, Scanner	N/A	8	2
Motor, Wire Cleaning	29-29634-01	6	16
OPTICAL ASSEMBLY	29-29631-01	8	N/A
OPTICAL ASSEMBLY	29-29631-01	2	1
Panel Unit , Operation Control	29-29641-01	4	9
Panel Unit, Operation (LCIT)	29-30260-01	14	3
Pawl, Fusing Unit Separation	29-29654-01	11	2
PCB RACK ASSEMBLY	N/A	2	N/A
PCB RACK ASSEMBLY	N/A	5	N/A
Photo-Interrupter (EE-SX460-P2)	29-27373-01	6	10
Photo-interrupter	29-27397-01	10	1
Photo-interrupter	29-27397-01	9	6
Photo-interrupter, Fusing Exit	29-30275-01	10	4
Photoreflector	12-37049-01	9	5
Photoreflector	29-30287-01	16	1
Photoreflector (GP2A10)	29-30287-01	12B	1
Photoreflector (GP2A10)	29-30287-01	13	1
Photosensor w/Actuator	29-30289-01	13	7
Photosensor w/Actuator	29-30297-01	13	6
Pivot, Left Corner	G0041638	4	7
Plate, Shield	29-30259-01	2	18
Plate, Shield	29-30259-01	21	4
Power Pack	29-29650-01	6	5
Power Supply (100V)	29-29626-01	2	5
Power Supply (200V)	29-29627-01	2	5
PrintServer 32 System	N/A	1	N/A
Pulley, (32T)	29-27380-01	7	2
Pulley, Fork Gate One Way	GB033002	10	10
Pulley, Idler (11.2mm)	GA134003	10	8
Pulley, MXL33	GB030029	10	12
Pulley, OPC Drive	GB030028	7	5

INDEX BY PART DESCRIPTION

PrintServer 32 System

DESCRIPTION	PART NO.	FIG. NO.	ITEM NO.
Receptacle Assembly, T/S Charger	17-03382-21	6	1
Receptacle, Main Charger	17-03382-20	6	9
Ring, Retaining (M3)	07200030E	13	103
Ring, Retaining (M4)	07200040E	12A	104
Ring, Retaining (M6)	07200060E	12A	101
Ring, Retaining (M6)	07200060E	9	102
Ring, Retaining M2.5	07200025E	10	105
Ring, Retaining M2.5	07200040E	10	105
Ring, Snap	54472681	2	101
Ring, Snap	54472681	22	8
Roller Assembly, Cleaning	N/A	11	5
Roller Assembly, Separation	29-25104-00	22	6
Roller Unit, Registration	29-30253-01	2	8
Roller, Feed	29-25102-00	22	5
Roller, Fork Gate Bottom Drive	G0134834	10	14
Roller, Fork Gate Drive	GF020021	10	16
Roller, Fork Gate Drive Entrance	G0134836	10	24
Roller, Fork Gate Drive Side Exit	GF023003	10	19
Roller, Fork Gate Entrance Idle	G0134838	10	17
Roller, Fork Gate Idle Side Exit	GF022005	10	18
Roller, Idle - 2	GF022002	10	15
Roller, Pick-Up	29-25103-00	22	4
Roller, Separation	29-29653-01	22	9
Screw, Phl Sunk M3 x 6	03230060B	9	103
Screw, Fusing Stopper Thumb	G0131447	2	21
Screw, Hex Headless Set M4 x 5	05740050E	15	102
Screw, Hex Headless Set M4 x 5	05740050E	7	101
Screw, Phil Truss Hd M4 x 6	03440060D	22	101
Screw Phl Hd w/Flat Washer M4 x 8	09514008B	10	104
Screw, Phl Hd w/ Flat Washer M4 x 8	09514008B	6	102
Screw, Phl Hd w/Flat Washer M4 x 8	09514008B	5	101
Screw, Phl Hd w/Flat Washer M4 x 8	09514008B	12A	105
Screw, Phl Hd w/Flat Washer M4 x 8	09514008B	7	102
Screw, Phl Hd w/Flat Washer M4	09514006B	4	102
Screw, Phl Hd w/Flat Washer M4 x 8	09514008B	4	106
Screw, Phl Hd w/Washer M3 x 6	09513006B	3	102
Screw, Phl Pan w/Flat Washer M3 x 5	09513005B	12B	102
Screw, Phl Pan Hd M4 x 6	03140060B	12B	104
Screw, Phl Pan Hd M4 x 6	03140060B	7	104
Screw, Phl Pan Hd M4 x 6	03140060B	5	102
Screw, Phl Pan Hd M4 x 6	03140060B	6	101
Screw, Phl Pan Hd M3 x 8	03130080B	12B	103
Screw, Phl Pan Hd M3 x 8	03130080B	13	101
Screw, Phl Pan Hd M3 x 8	03130080B	16	2
Screw, Phl Pan Hd M4 x 10	03140100B	9	104
Screw, Phl Pan Hd M3 x 4	03140040B	14	102
Screw, Phl Pan Hd M4 x 4	03140040W	15	103
Screw, Phl Pan Hd M4 x 6	03140060B	15	101
Screw, Phl Pan Hd M4 x 6	03140060B	12A	102
Screw, Phl Pan Hd M4 x 6	03140060B	13	102
Screw, Phl Pan Hd M4 x 6	03140060B	9	101
Screw, Phl Pan Hd M3 x 3	03130030B	11	106
Screw, Phl Pan Hd M3 x 3	08011135	11	103
Screw, Phl Pan Hd M3 x 30	03130300B	6	103

INDEX BY PART DESCRIPTION
PrintServer 32 System

DESCRIPTION	PART NO.	FIG. NO.	ITEM NO.
Screw, Phi Pan Hd M3 x 4	03130040B	10	103
Screw, Phi Pan Hd M3 x 5	03130050B	11	101
Screw, Phi Pan Hd M3 x 5	03130050B	4	105
Screw, Phi Pan Hd M4 X 10	03440100F	4	103
Screw, Phi Pan Hd M4 x 10	03140100B	10	101
Screw, Phi Pan Hd M4 x 4	03140040W	6	104
Screw, Phi Pan Hd M4 x 6	03140060B	10	102
Screw, Phi Pan Hd M4 x 6	03140060B	11	102
Screw, Phi Pan Hd M4 x 6	03140060B	3	101
Screw, Phi Pan Hd M4 x 6	03140060B	4	104
Screw, Phi Pan Hd Screw M3 x 5	03130050B	8	101
Screw, Phi Pan Hd Screw M4 x 10	03140100B	8	102
Screw, Phi Pan Hd w/Flat Washer 3 x 20	09513020B	6	105
Screw, Phi Pan Hd w/Flat Washer 3 x 25	09513025B	6	106
Screw, Phi Pan Hd w/Flat Washer M4	09514006B	11	104
Screw, Phi Pan w/Flat Washer M4 x 8	09514008B	12B	101
Screw, Phi Truss Hd M4 x 8	03440080F	14	101
Screw, Phi Truss Hd M4 x 6	03440060F	3	103
Screw, Phi Truss Hd M4 x 8	08011185	2	102
Screw, Phi Truss Hd Screw M4 x 6	03440060F	12A	103
Screw, Stepped M4	54195714	11	105
Screw, Stepped M4	AA143076	10	33
Screw, Tapping M4 x 10	09654010B	4	101
Sensor Set, Cleaning Unit	29-27362-01	6	2
Sensor Set, OPC Drum	29-27365-01	6	6
Shaft, Drive, OPC Drum	GD015001	7	8
Solenoid Assembly, DPX	29-30290-01	13	2
Solenoid Assembly, (LCIT FEED)	29-30301-01	15	3
Solenoid Assembly, Drum Separation Pawl	29-27400-01	6	11
Solenoid Assembly, Fork Gate	29-30274-01	10	3
Solenoid Assembly, LCOT	29-30284-01	12A	5
Solenoid, Cleaning Roller	29-29658-01	6	15
Spring, 100GF	GA063013	10	6
Spring, Drum Change Feeler Pressure	N/A	7	9
Spring, Feeler Drum Change Sensor	29-30270-01	7	7
Spring, Fork Gate	G0134811	10	23
Spring, Lower Tray	29-30268-01	4	19
Spring, Overflow Feeler	G0134814	10	5
Spring, Tray Upper	29-30282-01	12	8
Stay Assembly, Job Separation (LCOT)	29-30285-01	12A	6
Stay Assembly, Upper (Feeler Exit) (LCOT)	29-30347-01	12B	3
Strap, Thumb Screw	G0131448	2	22
Switch, Fusing Unit Interlock	29-29642-01	6	8
Switch, Interlock (LCOT, Left Cover)	12-37037-01	12A	4
Switch, Left Cover Interlock	29-27363-01	6	4
Switch, Toner Overflow	29-27369-01	4	16
Table Assembly, LPS32 w/Door (Empty)	N/A	3	5
Thermistor and Fuse Assembly	29-30278-01	11	3
Tightener Assembly - 1	G0134874	10	29
Timing Belt, (116XL)	12-37042-01	9	2
Tool, T/S Charger (LPS32)	29-30524-01	3	3
Transport Unit	29-29643-01	2	3
Tray, LCOT Upper Exit	29-27392-01	12	5
Tray, Side Exit	G0041675	4	5

INDEX BY PART DESCRIPTION

PrintServer 32 System

DESCRIPTION	PART NO.	FIG. NO.	ITEM NO.
Tray, Stacking	29-30267-01	12	7
Tray, Stacking	29-30267-01	4	18
UNIT COMPONENTS, LPS32 MAIN	N/A	2	N/A
UNIT COMPONENTS, LPS32 TABLE	N/A	3	N/A
UNIT COMPONENTS - SECTION 1, (LCOT)	N/A	12	N/A
UNIT COMPONENTS - SECTION 2, (LCOT)	N/A	12A	N/A
UNIT COMPONENTS - SECTION 3, (LCOT)	N/A	12B	N/A
Vacuum Cleaner (100V)	29-25526-00	1	Not Shown
Vacuum Cleaner (200V)	29-26259-00	1	Not Shown
Video, PrintServer 32 User Maintenance	EK-PRNTR-UD	1	Not Shown
WIRE, MAIN AUTO	29-30258-01	2	14
Wire, Main Auto	29-30258-01	21	2
WIRE, T/S CHARGE	29-30252-01	2	16
Wire, T/S Charge	29-30252-01	21	3
Wire Assembly, T/S	29-30256-01	2	9