

**ILLUSTRATED
PARTS
BREAKDOWN**

**DEClaser
1100/1152**

ILLUSTRATED PARTS BREAKDOWN (IPB)

The IPB is used to identify a part and its location in a hardware product. The document references specific item numbers in the associated parts list.

HOW TO USE THE IPB

1. Locate the figure containing the item of interest.
2. Locate the number (callout) of the item of interest.
3. Locate that item number in the associated parts list.

FORMAT

Each IPB is generally organized based on its first figure. All other assemblies and subassemblies are referenced from this figure. Each figure contains numeric callouts of all major parts (items).

PARTS LIST

Each parts list contains the following:

Figure and Item No. – Lists the figure number and its referenced numeric callout

Description – Presents the name and a brief description of the item. A single asterisk (*) preceding the description denotes item is a

subassembly to its referenced figure. A double asterisk (**) preceding the description indicates that this item is subordinate to the preceding single asterisk item.

DEC Part No. – Lists the Digital/Vendor part number. The letter in the column heading indicates the current revision level of the Engineering Drawing for the referenced figure.

ECO Cut-In – Lists the top assembly drawing number and revision level at first printing. All additional revisions to an item are listed in this column.

Used On Code – Lists letters referring to the product variation assigned in Figure 1. When this column is blank, the item is used in all variations.

Ref Fig No. – Lists a cross reference between figures within the IPB.

PART NUMBER/PART DESCRIPTION INDEX SECTION

Lists items by part number numerically, and description alphabetically. Items are also referenced to a location within the IPB by figure and item number.

ECO/REVISION HISTORY

**OTHER IPB
MANUALS
REFERENCED**

FIGURE NO.	ASSEMBLY	INITIAL LEVEL	CURRENT LEVEL	PRINTING DATE	OTHER IPB MANUALS REFERENCED
1	LN07 LN07C	00000 00000	00000 00000	23-NOV-92	N/A

Digital Equipment Corporation reserves the right, without notice, to make substitutions and modifications in the specifications of products documented in this manual and further reserves the right to withdraw any of these products from the market without notice.

Digital Equipment Corporation is not responsible for errors which may appear in the technical description (including illustrations and photographs) of the products covered by this manual.

None of the descriptions contained in this manual imply the granting of any license whatsoever to make, use or sell equipment constructed in accordance therewith.

Restricted Rights: Use, duplication or disclosure by the U.S. Government is subject to restrictions as set forth in subparagraph (c) (1) (ii) of the Rights in Technical Data and Computer Software clause at DFARS 252.227-2713.

Copyright © 1992 by Digital Equipment Corporation. All rights reserved.
Printed in U.S.A.

The postage-paid READER'S COMMENTS form on the last page of this document requests your critical evaluation to assist us in preparing future documentation.

The following are trademarks of Digital Equipment Corporation :

DECdirect, DEClaser and the DIGITAL logo.

PostScript is a registered trademark of Adobe Systems, Inc.
All other trademarks and registered trademarks are the property of their respective holders.

LIST OF ASSEMBLIES

FIGURE NUMBER	TITLE	PAGE NUMBER
1	ASSEMBLY LOCATIONS – DECLaser 1100/1152	1
2	PANELS/EXTERNAL COVERS, ETC	7
3	COVER ASSEMBLY, FRONT	9
4	COVER ASSEMBLY, UPPER	13
5	COVER ASSEMBLY INTERNAL	15
6	COMPONENTS ASSEMBLY, INTERNAL	17
7	PLATE ASSEMBLY, MACHINE BOTTOM	19
8	FIXING ASSEMBLY	21
9	CONTACT ASSEMBLY, H.V.	25
10	DRIVE ASSEMBLY	26
11	ROD ASSEMBLY	27
12	ROLLER ASSEMBLY, TRAY PICK-UP	28
13	FEEDER ASSEMBLY	29
14	DELIVERY ASSEMBLY, FACE-DOWN	30
15	CONTROLLER ASSEMBLY, VIDEO	31
16	FEEDER ASSEMBLY, CASSETTE	33
17	CASSETTE ASSEMBLY (A4, LGL)	35
18	CASSETTE ASSEMBLY (LTR, EXE)	37
19	CASSETTE ASSEMBLY (ENVELOPE)	39
	LIST of STANDARD FASTENERS	A-1
	PART NUMBER INDEX	B-1
	PART DESCRIPTION INDEX	C-1

THIS PAGE INTENTIONALLY LEFT BLANK

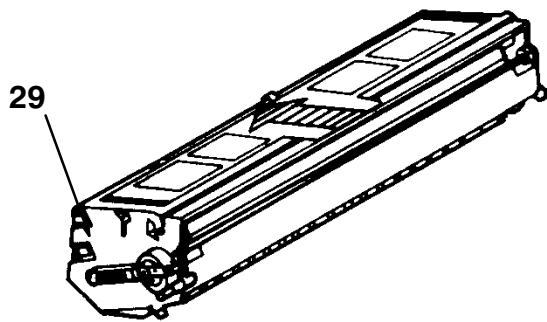
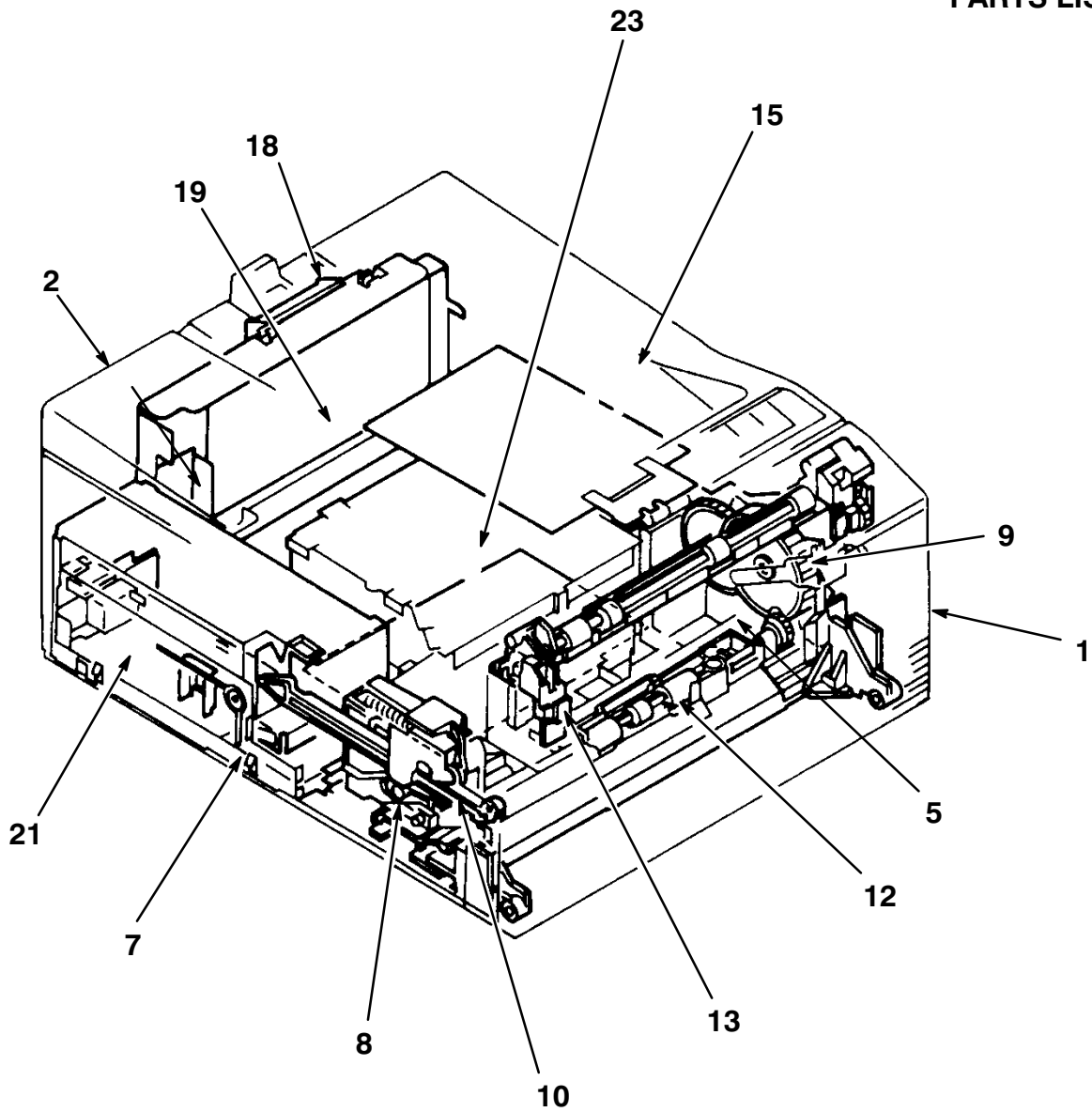

D1100-01-SC

Figure 1. Assembly Locations – DEClaser 1100/1152 (Sheet 1 of 3)

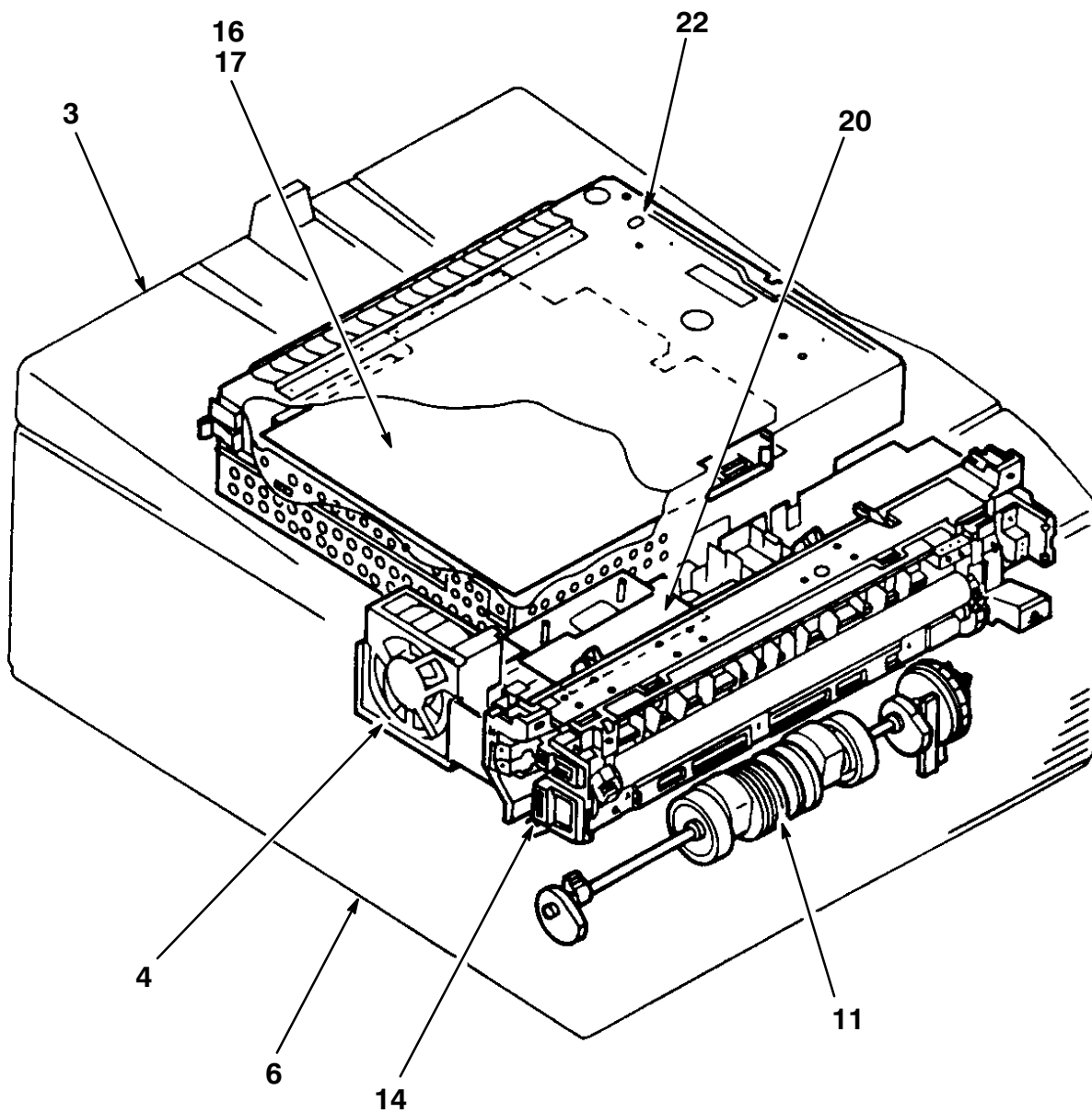

D1100-01A-SC

Figure 1. Assembly Locations – DEClaser 1100/1152 (Sheet 2 of 3)

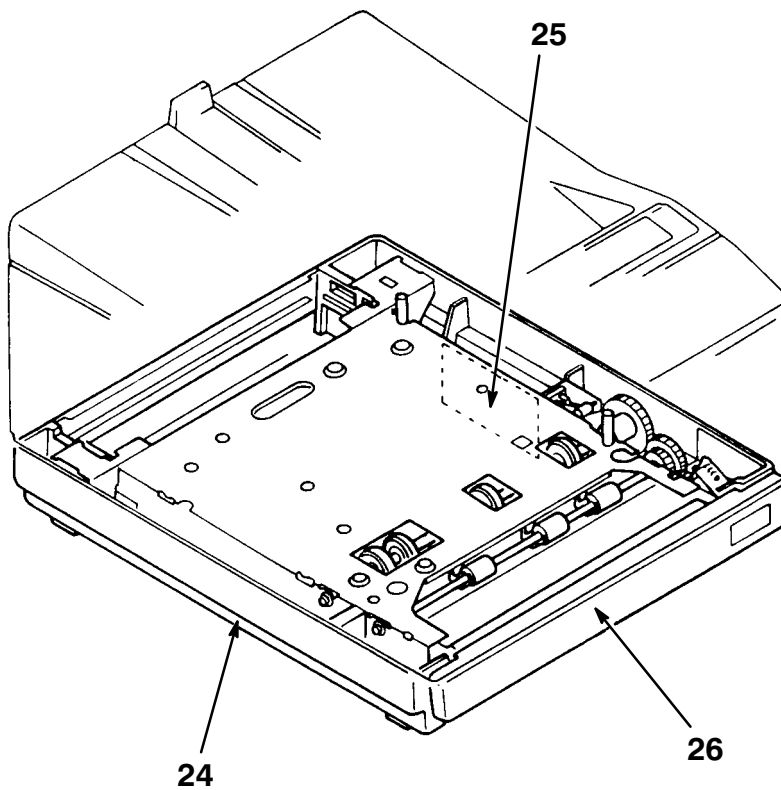
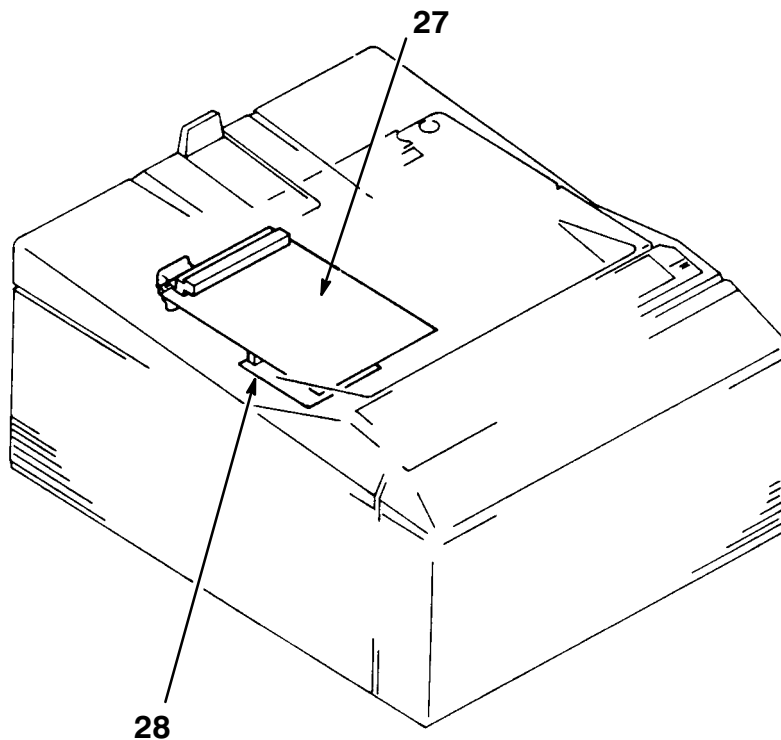

D1100-01B-SC

Figure 1. Assembly Locations – DEClaser 1100/1152 (Sheet 3 of 3)

FIG. & ITEM NO.	DESCRIPTION	VENDOR PART NO.	DEC PART NO.	USED ON CODE	REF FIG NO.
1-	DEClaser 1100 PRINTER ASSEMBLY (30-34808-01) (110/115V)		LN07-A2	A	
	DEClaser 1100 PRINTER ASSEMBLY (30-34808-02) (220/240V)		LN07-A3	B	
	DEClaser 1152 PRINTER ASSEMBLY (30-39642-01) (100/115V)		LN07C-A2	C	
	DEClaser 1152 PRINTER ASSEMBLY (30-39642-02) (220/240V)		LN07C-A3	D	
1	*PANELS/EXTERNAL COVERS, ETC.	N/A			2
2	*COVER ASSEMBLY, FRONT (100/115V)		29-29015-01	A	3
	*COVER ASSEMBLY, FRONT (100/115V)		29-30567-01	C	3
	*COVER ASSEMBLY, FRONT (220/240V)		29-29016-01	B	3
	*COVER ASSEMBLY, FRONT (220/240V)		29-30568-01	D	3
3	*COVER ASSEMBLY, UPPER	N/A			4
4	*COVER ASSEMBLY, INTERNAL	RG1-1915-000			5
5	*COMPONENTS ASSEMBLY, INTERNAL	N/A			6
6	*PLATE ASSEMBLY, MACHINE BOTTOM	N/A			7
7	*Inlet Assembly, Power (100/115V)		29-29006-01	AC	
	*Inlet Assembly, Power (220/240V)		29-29021-01	BD	
8	*CONTACT ASSEMBLY, H.V.	RG1-1780-000			9
9	*DRIVE ASSEMBLY		29-29003-01		10
10	*ROD ASSEMBLY	RG1-1781-000			11
11	*ROLLER ASSEMBLY, TRAY PICK-UP		29-29005-01		12
12	*FEEDER ASSEMBLY		29-29004-01		13
13	*DELIVERY ASSEMBLY, FACE-DOWN	RG1-1791-000			14
14	*FIXING ASSEMBLY (100/115V)		29-29014-01	AC	8
	*FIXING ASSEMBLY (220/240V)		29-29020-01	BD	8
15	*Module Assembly, DC Controller		29-28997-01		
16	*Module Assembly, Video Controller		29-29018-01		
17	*Module Assembly, ROM	SG5-4115-000			
18	*Interface Assembly	RG1-1823-000			
19	*Module Assembly, Interface		29-29013-01		
20	*Module Assembly, Density Adjusting		29-29008-01		
21	*Module Assembly, AC Controller (100/115V)	RG1-1835-000		AC	
	*Module Assembly, AC Controller (220/240V)	RG1-1836-000		BD	

FIG. & ITEM NO.	DESCRIPTION	VENDOR PART NO.	DEC PART NO.	USED ON CODE	REF FIG NO.
1-					
22	*CONTROLLER ASSEMBLY, VIDEO	RG1-2633-000			15
23	*Module Assembly, H.V. Power Supply		29-28999-01		
24	*FEEDER ASSEMBLY, CASSETTE	N/A			16
25	**Module Assembly, Cassette Feeder		29-28998-01		
26	*CASSETTE ASSEMBLY (A4, LGL)	N/A			17
	*CASSETTE ASSEMBLY (LTR, EXE)	N/A			18
	*CASSETTE ASSEMBLY (ENVELOPE)	N/A			19
27	*Module Assembly, RAM-V		LN07X-MA		
28	*Module Assembly, RAM-C		LN07X-MC		
	MISCELLANEOUS (Not Shown)				
	*Cord, Power (USA)		17-00083-09	A	
	*Documentation, User (English)		EK-D1100-DK	C	
	MISCELLANEOUS PARTS & DOCUMENTATION (Not Shown)				
	*Tray, A4 Size Paper Input		LN07X-TA		
	*Cassette, Legal Size Paper		LN07X-TB		
	*Cassette, Letter Size Paper		LN07X-TC		
	*Cassette, Envelope Size		LN07X-TD		
	*Cassette, Executive Size Paper		LN07X-TE		
	*Cassette, Optional Lower w/Letter Tray		LN07X-TF	A	
	*Tray, Large Capacity Letter Size Paper		LN07X-TG	B	
	MISCELLANEOUS KITS & SUPPLIES (Not Shown)				
	*Kit, Toner/Supplies Cartridge		LN07X-AA		
	*KIT, POSTSCRIPT UPGRADE (VMS SWL)		LN07R-UA		
	** Cartridge, POSTSCRIPT ROM (30-34892-01)		LN07X-PS		
	**Card, 1 MB RAM (20-34856-01)		LN07X-UC		
	**Module, 1 MB Daughter Board Add-On (12-34857-01)		LN07X-UE		
	*KIT, POSTSCRIPT UPGRADE (2 MB Mem)		LN07U-UA		
	**Cartridge, POSTSCRIPT ROM (30-34892-01)		LN07U-PS		
	*Module, Memory Option 2 MB RAM (DEC laser 1152 Only)		LN07X-UF	CD	

FIG. & ITEM NO.	DESCRIPTION	VENDOR PART NO.	DEC PART NO.	USED ON CODE	REF FIG NO.
1-	<p style="text-align: center;">CABLES (Not Shown)</p> <p>DENMARK Cord, Power Cable Assembly, 6 Cond. EIA-423 MMJ</p> <p>UK/IRELAND Cord, Power Cable Assembly, 6 Cond. EIA-423 MMJ</p> <p>GERMAN/AUSTRIA Cord, Power Cable Assembly, Shielded EIA-423 MMJ</p> <p>ITALIAN Cord, Power Cable Assembly, 6 Cond. EIA-423 MMJ</p> <p>ISRAEL Cord, Power Cable Assembly, 6 Cond. EIA-423 MMJ</p> <p>AUSTRALIA/NEW ZEALAND Cord, Power Cable Assembly, 6 Cond. EIA-423 MMJ</p> <p>SWITZERLAND Cord, Power Cable Assembly, 6 Cond. EIA-423 MMJ</p> <p>BELGIUM, FINLAND, FRANCE, HOLLAND, NORWAY, PORTUGAL, SPAIN, SWEDEN Cord, Power Cable Assembly, 6 Cond. EIA-423 MMJ</p>		<p>17-00310-08 17-00811-02</p> <p>17-00209-15 17-00811-02</p> <p>17-00199-21 17-01364-01</p> <p>17-00364-18 17-00811-02</p> <p>17-00457-16 17-00811-02</p> <p>17-00198-14 17-00811-02</p> <p>17-00210-13 17-00811-02</p> <p>17-00199-21 17-00811-02</p>	<p>BD BD</p> <p>BD BD</p> <p>BD BD</p> <p>BD BD</p> <p>BD BD</p> <p>BD BD</p> <p>BD BD</p>	

FIG. & ITEM NO.	DESCRIPTION	VENDOR PART NO.	DEC PART NO.	USED ON CODE	REF FIG NO.
2-	PANELS/EXTERNAL COVERS, ETC.	N/A			1
1	*Panel, Right	RA2-0878-000			
2	*Panel, Left	RA2-0877-000			
3	*PANEL, REAR	RF1-3171-000			
3A	**Screw, TP M3 x 10	XA9-0495-000			
3B	**Ring	RA1-7560-000			
4	*Tray, Face-Up	RA1-7630-080			
5	*Tray Assembly, Multi-Purpose		29-29019-01		

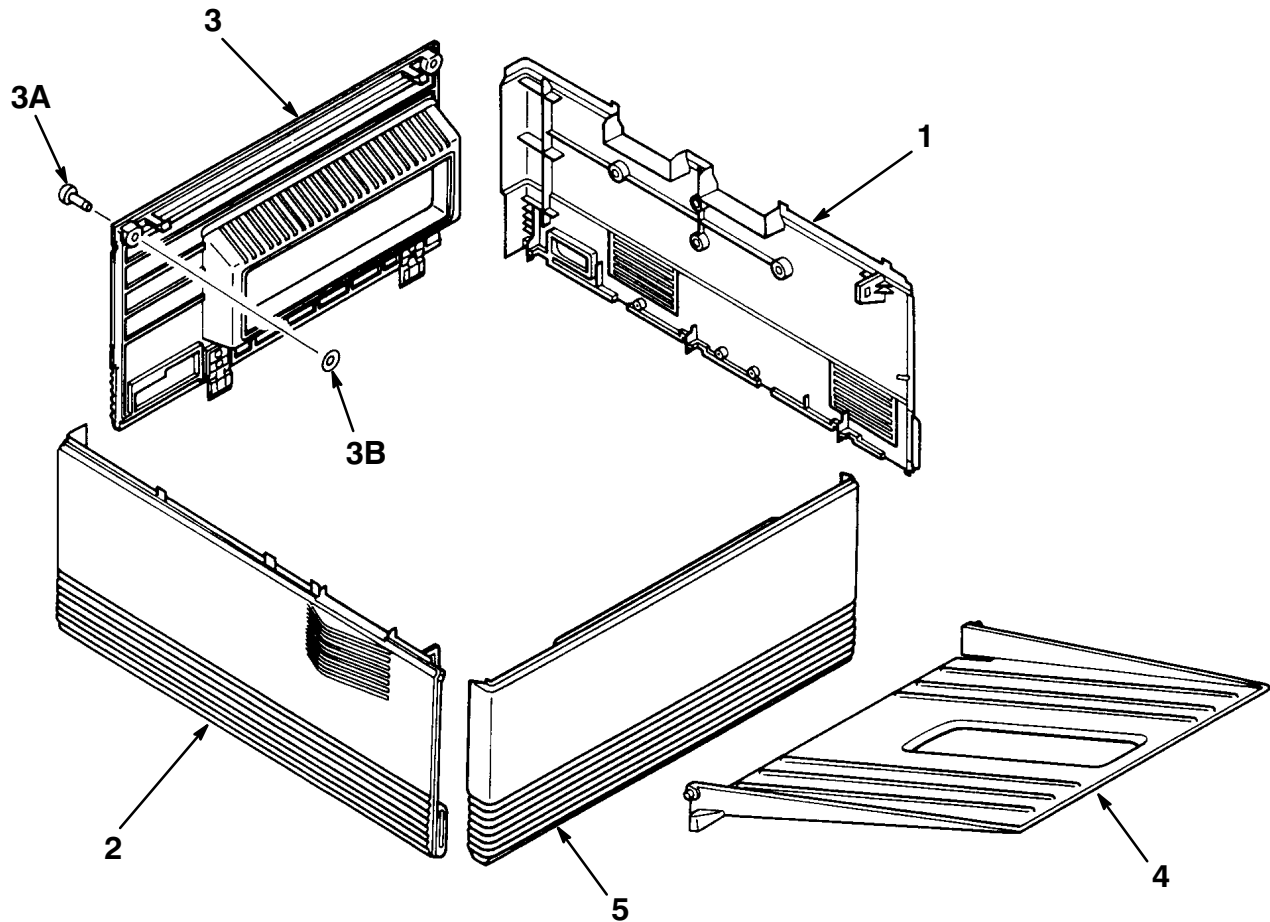

D1100-02-BD

Figure 2. Panels/External Covers, Etc.

THIS PAGE INTENTIONALLY LEFT BLANK

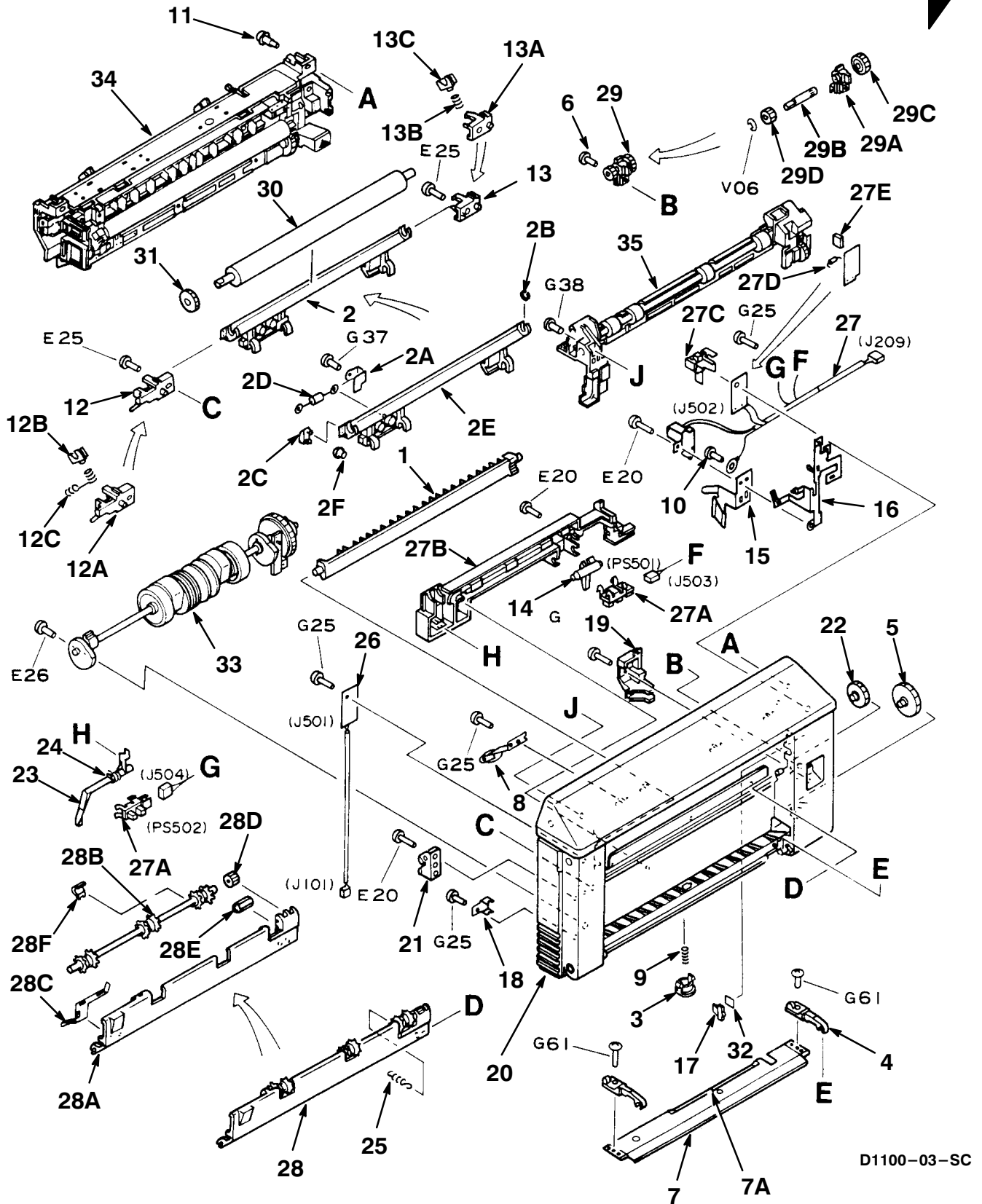

Figure 3. Cover Assembly, Front

D1100-03-SC

FIG.& ITEM NO.	DESCRIPTION	VENDOR PART NO.	DEC PART NO.	USED ON CODE	REF FIG NO.
3-	COVER ASSEMBLY, FRONT (LN07) (115V)		29-29015-01	A	1
	COVER ASSEMBLY, FRONT (LN07) (240V)		29-29016-01	B	1
	COVER ASSEMBLY, FRONT (LN07C) (115V)		29-30567-01	A	1
	COVER ASSEMBLY, FRONT (LN07C) (240V)		29-30568-01	B	1
1	*Deflector	RA1-7626-000			
2	*GUIDE ASSEMBLY, TRANSFER	RG9-0681-000			
2A	**Plate, Grounding	RA1-7825-000			
2B	**Bushing	RA1-8233-000			
2C	**Plate	RA1-8234-000			
2D	**Resistor, 68M OHM, 1/2W	RH6-3091-000			
2E	**Guide	RF1-2496-000			
2F	**Contact	RA1-8254-000			
3	*Cap, Spring	RA1-7628-000			
4	*Arm, Paper Pick-up	RA1-7629-000			
5	*Gear, 30T	RS1-0290-000			
6	*Screw, TP M3 x 12	XA9-0382-000			
7	*PLATE, PAPER GUIDE	RF1-2400-050			
7A	**Guide, Sheet	RA1-7625-000			
8	*Roller, Delivery	RF1-2491-000			
9	*Spring, Compression	RS1-2244-000			
10	*Screw, w/Washer M3 x 8	XB2-7300-807			
11	*Screw, Stepped M3	RA9-0621-000			
12	*MOUNT ASSEMBLY, LEFT TR ROLLER	RG1-1793-000			
12A	**Retainer, TR Left	RA1-7621-000			
12B	**Bushing	RA1-7623-000			
12C	**Spring, Compression	RS1-2242-000			
13	*MOUNT ASSEMBLY, RIGHT TR ROLLER	RG1-1794-030			
13A	**Retainer, TR Right	RA1-7622-020			
13B	**Bushing	RA2-0757-000			
13C	**Spring, Compression	RS1-2242-000			
14	*Lever, Paper Sensor	RA1-7562-000			
15	*Plate A, Grounding	RA1-7565-000			
16	*Plate B, Grounding	RA1-7566-000			
17	*Plate, Hook Shaft	RA1-8255-000			
18	*Holder, Cord	RA1-7637-000			

FIG. & ITEM NO.	DESCRIPTION	VENDOR PART NO.	DEC PART NO.	USED ON CODE	REF FIG NO.
3-					
19	*Cover, Front Cord	RA1-7632-000			
20	*Panel, Front	N/A			
21	*Mount, Rod	RA1-7563-000			
22	*Gear, 20T	RS1-0291-000			
23	*Arm, Sensing	RA1-7717-000			
24	*Spring, Torsion	RA1-7718-000			
25	*Spring, Tension	RS1-2253-000			
26	*Module Assembly, Fixing AC	RG1-1602-000			
27	*CABLE ASSEMBLY	RG1-1608-000			
27A	**Photo-Interrupter	WG8-0323-000			
27B	**Mount, Sensor	RA1-7570-000			
27C	**Guide, Cord	RA1-7579-000			
27D	**Diode, SHV-02	WA1-1124-000			
27E	**Pin Assembly, 3P	RH2-5105-000			
28	*COVER ASSEMBLY, FACE-UP	RG1-1832-000			
28A	**Cover, Front Upper	RA1-7721-000			
28B	**Roller, Delivery	RA1-7714-000			
28C	**Plate, Grounding	RA1-7716-000			
28D	**Gear, 15T	RS1-0306-000			
28E	**Gear, 14T	RS1-0305-000			
28F	*Support, Roller	RA1-7822-000			
29	*DRIVE ASSEMBLY, FACE-UP DELIVERY	RG1-1833-000			
29A	**Support, Roller	RA1-7611-000			
29B	**Shaft	RA1-7715-000			
29C	**Gear, 14T	RS1-0288-000			
29D	**Gear, 15T	RS1-0304-000			
30	*Roller, Transfer		29-28994-01		
31	*Gear, 27T	RS1-0292-000			
32	*Tape	RA9-0689-000			
33	*ROLLER ASSEMBLY, TRAY PICK-UP		29-29005-01		12
34	*FIXING ASSEMBLY (100/115V)		29-29014-01	AC	8
	*FIXING ASSEMBLY (220/240V)		29-29020-01	BD	8
35	*DELIVERY ASSEMBLY, FACE DOWN	RG1-1791-070			14

THIS PAGE INTENTIONALLY LEFT BLANK

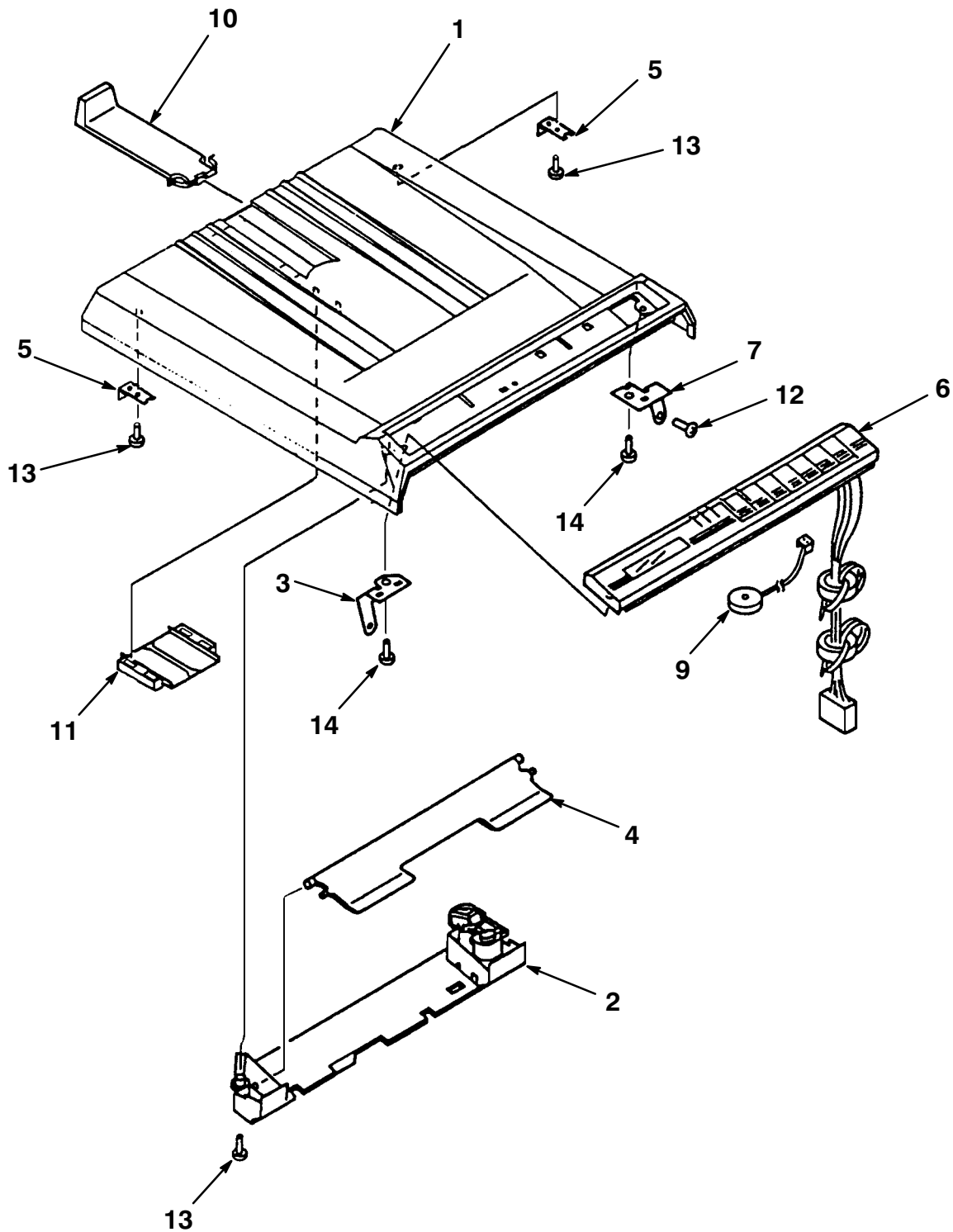

D1100-04-SC

Figure 4. Cover Assembly, Upper

FIG. & ITEM NO.	DESCRIPTION	VENDOR PART NO.	DEC PART NO.	USED ON CODE	REF FIG NO.
4-	COVER ASSEMBLY, UPPER	N/A			1
1	*Cover, Upper	RF1-3170-000			
2	*Guide, Paper	RA2-0876-000			
3	*Plate, Left Mounting	RA1-7528-000			
4	*Plate, Paper Support	RA1-7550-000			
5	*Mounting, Rear Cover	RA1-7551-000			
6	*Panel, Control (DECLaser 1100)		29-29017-01	AB	
	*Panel, Control (DECLaser 1152)		29-30569-01	CD	
7	*Plate, Right Mounting	RA1-7532-000			
8	*Not Used				
9	*Buzzer	SH8-4167-000			
10	*Slider	RA2-0081-000			
11	*Guide, Slide	RA1-7549-000			
12	*Screw,	XA9-0535-000			
13	*Screw, M3 x 10	XA9-0475-000			
14	*Screw	XA9-0516-000			

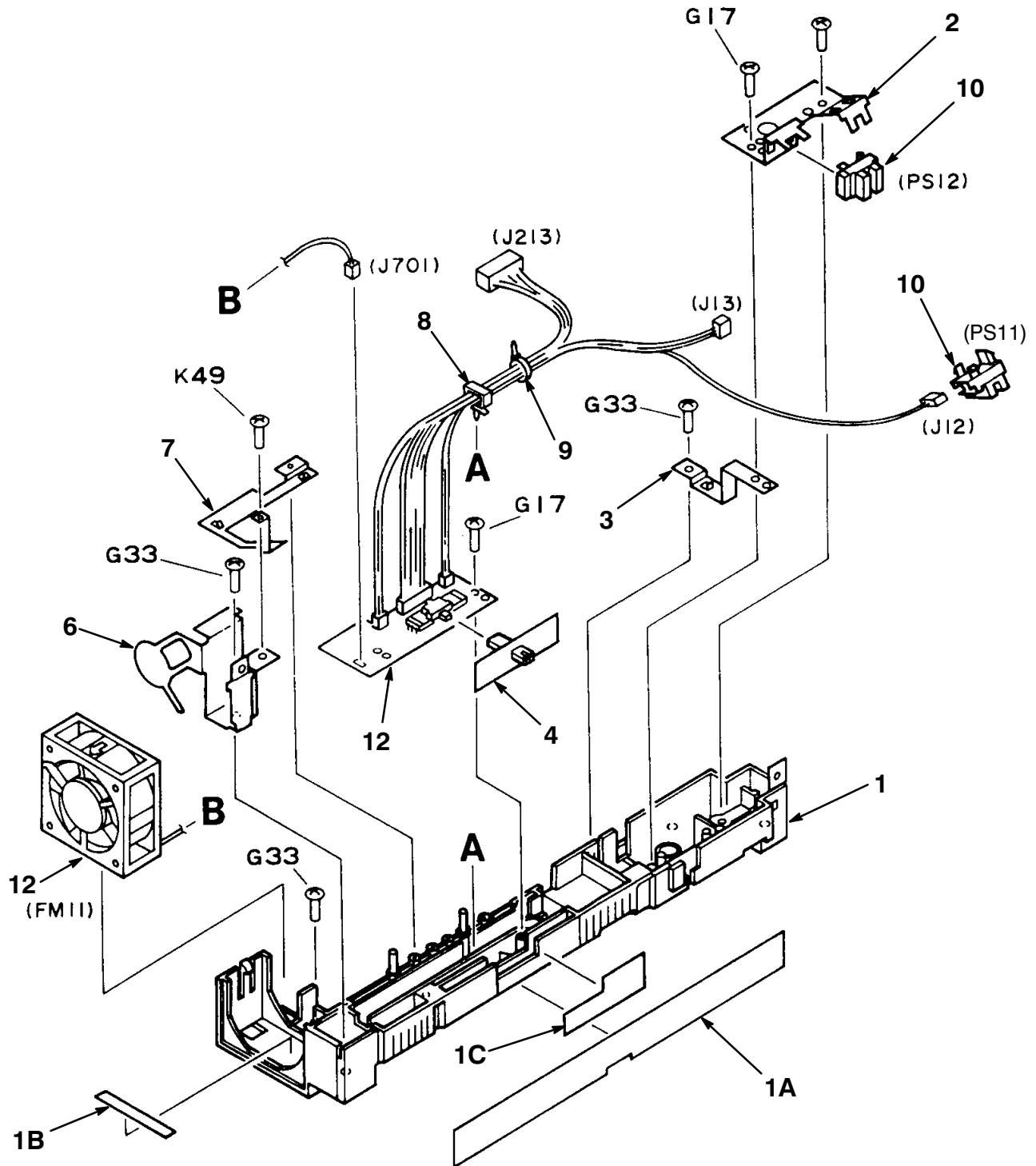

D1100-05-SC

Figure 5. Cover Assembly, Internal

FIG. & ITEM NO.	DESCRIPTION	VENDOR PART NO.	DEC PART NO.	USED ON CODE	REF FIG NO.
5-	COVER ASSEMBLY, INTERNAL	RG1-1915-000			1
1	*COVER, INNER	RF1-2501-000			
1A	**Sheet	RA1-7818-000			
1B	**Pad	RA1-8227-000			
1C	**Label	RS1-8790-000			
2	*Plate, Sensor Mounting	RA2-0762-000			
3	*Plate, Grounding	RA1-7456-000			
4	*Slider, Print Density	RA1-8262-000			
5	*Not Used	N/A			
6	*Plate Nut, Left	RA1-7459-000			
7	*Plate, Grounding (2)	RA1-7811-000			
8	*Clip, Cable	WT2-0317-000			
9	*Tie, Cable	WT2-0505-000			
10	*Photo-Interrupter TLP1230	WG8-0291-000			
11	*Fan, 2.64W DC 12V		29-29009-01		
12	*Module Assembly, Density Adjusting (See Note)		29-29008-01		
	NOTE: This part shown for reference only, not part of this assembly.				

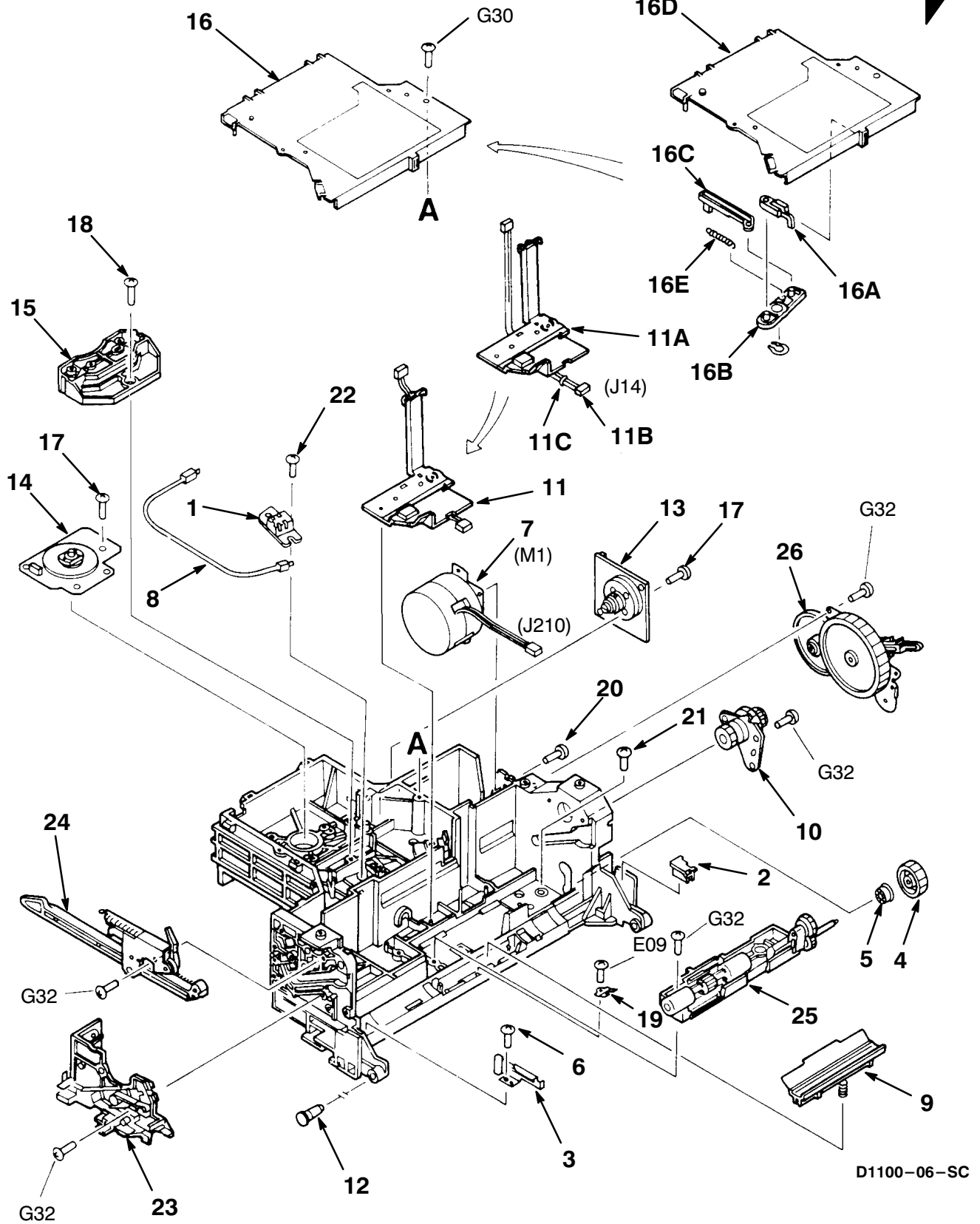
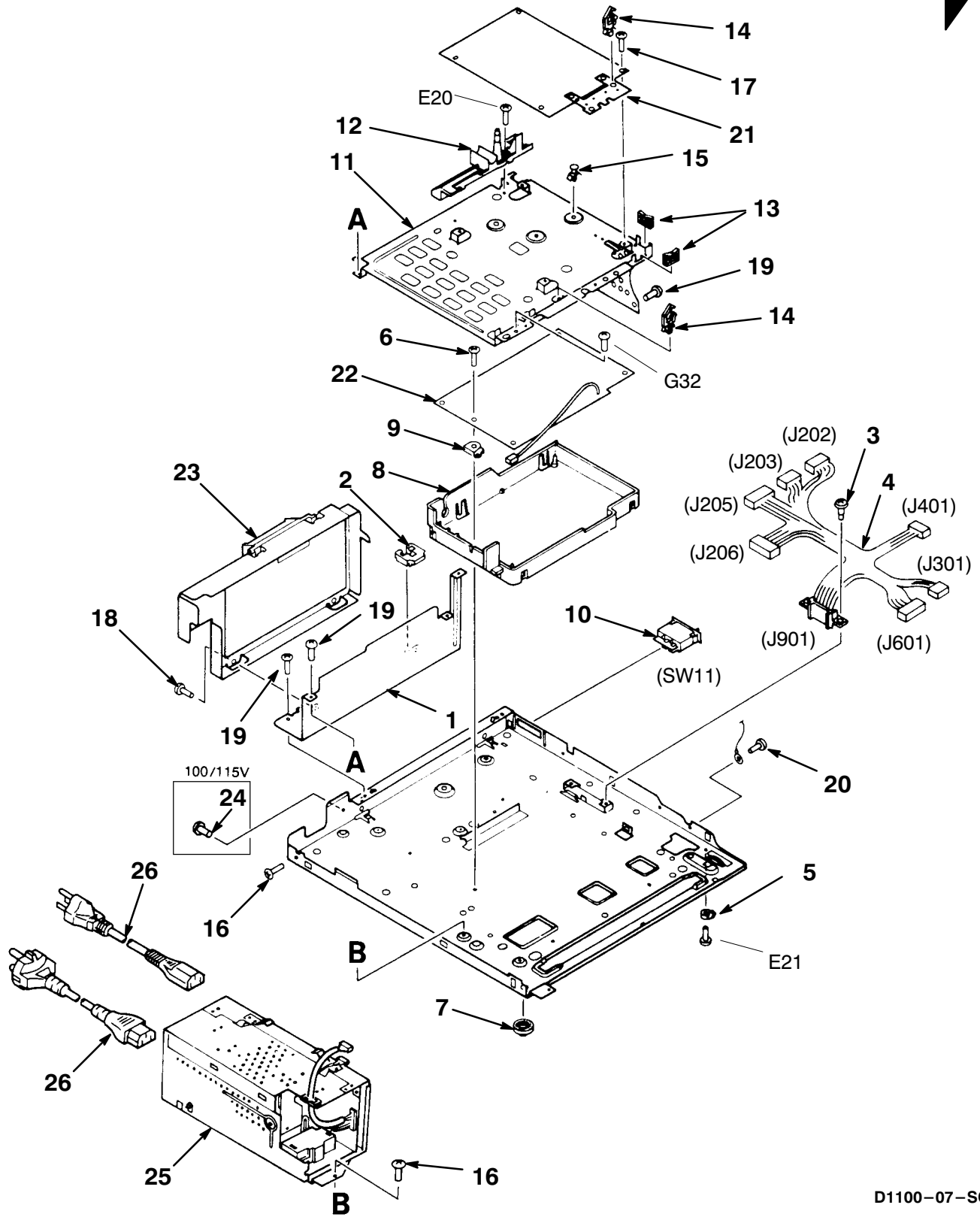

Figure 6. Components Assembly, Internal

FIG. & ITEM NO.	DESCRIPTION	VENDOR PART NO.	DEC PART NO.	USED ON CODE	REF FIG NO.
6-	COMPONENTS ASSEMBLY, INTERNAL	N/A			1
1	*Block, Fiber Holder	RA1-7446-000			
2	*Cover, Cord	RA1-7506-000			
3	*Plate, Tray Stopper	RA1-7507-000			
4	*Gear, 30T	RS1-0284-000			
5	* Bushing	RS1-1048-000			
6	*Screw, w/Washer M3 x 16	XA9-0488-000			
7	*Motor, Main Stepping DC 4W		29-29010-01		
8	*Cable Assembly, Optical Fiber	RH2-5104-000			
9	*Pad, Separation		29-29007-01		
10	*Drive Assembly, Drum	RG1-1777-000			
11	*CABLE ASSEMBLY, PICK-UP SENSOR	RG1-1612-000			
11A	**Cover, Cable	RA1-7502-000			
11B	**Cable, Sensor	RF1-2385-000			
11C	**Tie, Cable	WT2-0389-000			
12	*Pivot	RA1-7499-000			
13	*Laser Assembly		29-29000-01		
14	*Motor Assembly, Scanner		29-29001-01		
15	*Lens Assembly		29-29002-01		
16	*SHUTTER ASSEMBLY	RG1-1773-040			
16A	**Arm, No. 1	RA1-7440-030			
16B	**Arm, No. 2	RA1-7441-000			
16C	**Arm, No. 3	RA1-7442-000			
16D	**Cover	RF1-2511-030			
16E	**Spring, Tension	RS1-2234-000			
17	*Screw, Machine Truss Head M3 x 16	XA9-0459-000			
18	*Screw, Machine Truss Head M3 x 10	XA9-0462-000			
19	*Plate, Grounding	RA1-7639-000			
20	*Screw, Machine Truss Head M3 x 8	XA9-0259-000			
21	*Screw, Machine Truss Head M4 x 10	XA9-0497-000			
22	*Screw, Machine Truss Head M3 x 10	FA9-1643-000			
23	*CONTACT ASSEMBLY, H.V. (See Note)	RG1-1780-000			9
24	*ROD ASSEMBLY (See Note)	RG1-1781-000			11
25	*FEEDER ASSEMBLY (See Note)		29-29004-01		13
26	*DRIVE ASSEMBLY (See Note)		29-29003-01		10
	NOTE: This part shown for reference only, not part of this assembly.				



D1100-07-SC

Figure 7. Plate Assembly, Machine Bottom

FIG. & ITEM NO.	DESCRIPTION	VENDOR PART NO.	DEC PART NO.	USED ON CODE	REF FIG NO.
7-	PLATE ASSEMBLY, MACHINE BOTTOM	N/A			1
1	*Plate, Stack-End	RA1-7535-000			
2	*Guide, I/O	RA1-7536-000			
3	*Screw, Stepped M3	RA9-0621-000			
4	*Cable Assembly, Rear	RG1-1609-000			
5	*Foot	RA1-7453-000			
6	*Screw, M3	RA9-0603-000			
7	*Foot, Rubber	XH9-0059-000			
8	*Cover, H.V. Power Supply	RA1-7475-000			
9	*Plate, Grounding	RA1-7816-000			
10	*Switch, Rocker	RH7-6016-000			
11	*Mount, PCB (Module)	RA1-7533-000			
12	*Mount, Positioning	RA1-7552-000			
13	*Clip, Cable	WT2-5011-000			
14	*Clip, Cable	WT2-0317-000			
15	*Support, PCB (Module)	VT2-0016-004			
16	*Screw, w/Washer M3 x 6	XA9-0500-000			
17	*Screw, M3 x 6 (TP)	XA9-0267-000			
18	*Screw, Machine Truss Head M3 x 8	XA9-0259-000			
19	*Screw, w/Washer M3 x 8	XA9-0498-000			
20	*Screw, M3 x 8 (TP)	XA9-0302-000			
21	*Module Assembly, DC Controller		29-28997-01		
22	*Module Assembly, H.V. Power Supply		29-28999-01		
23	*Interface Assembly (DEClaser 1100)		29-29013-01	AB	
	*Interface Assembly (DEClaser 1152)		29-30383-01	CD	
24	*Screw, w/Washer M4	XA9-0499-000			
25	*Power Inlet Assembly (100/115V)		29-29006-01	AC	
	*Power Inlet Assembly (220/240V)		29-29021-01	BD	
26	*Cord, Power (100/115V)	RH2-5115-000			
	*Cord, Power (220/240V)	RH2-5116-000			
	NOTE: Items 21, 22, 23 are shown for reference only, not part of this assembly.				

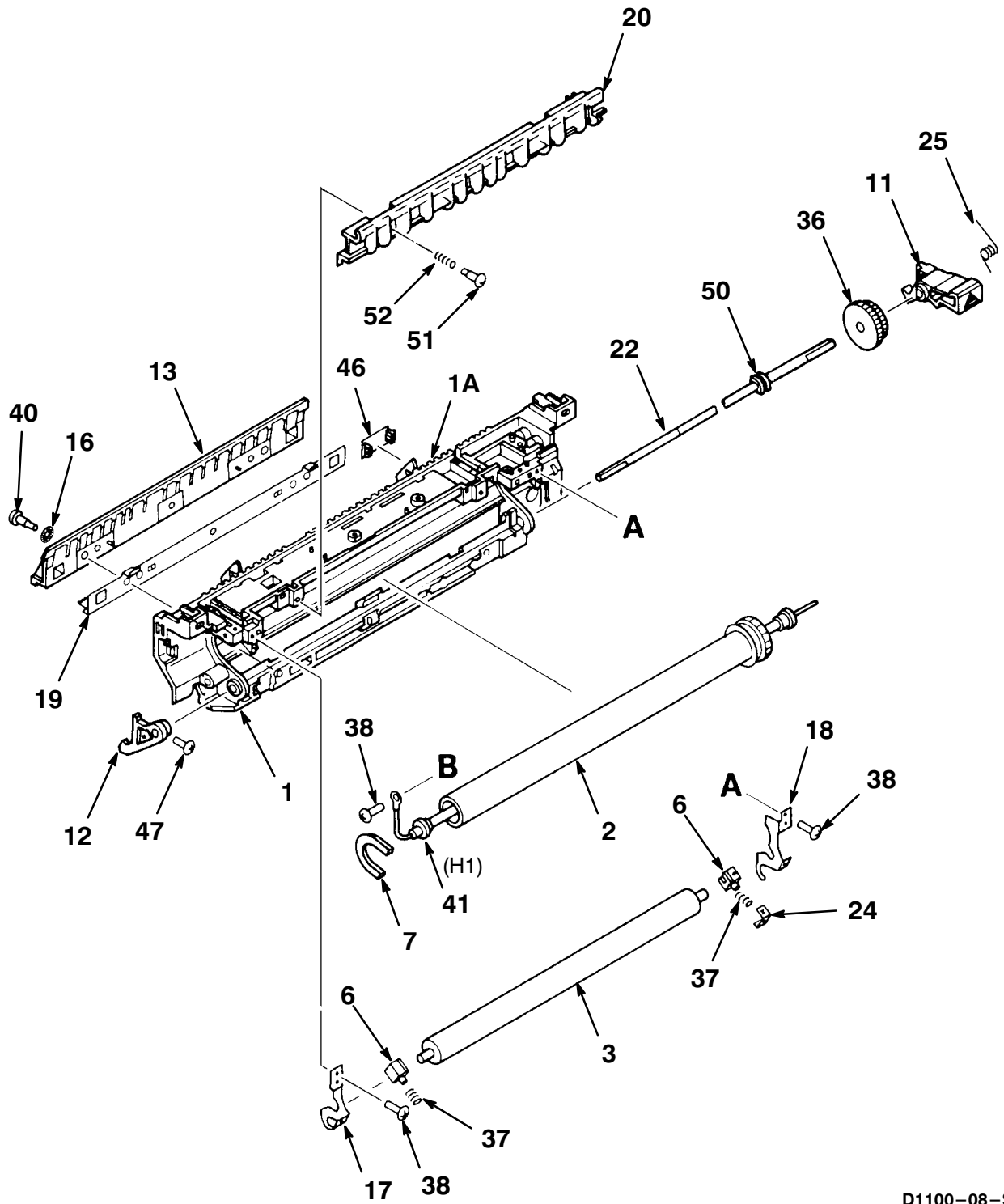

D1100-08-SC

Figure 8. Fixing Assembly (Sheet 1 of 2)

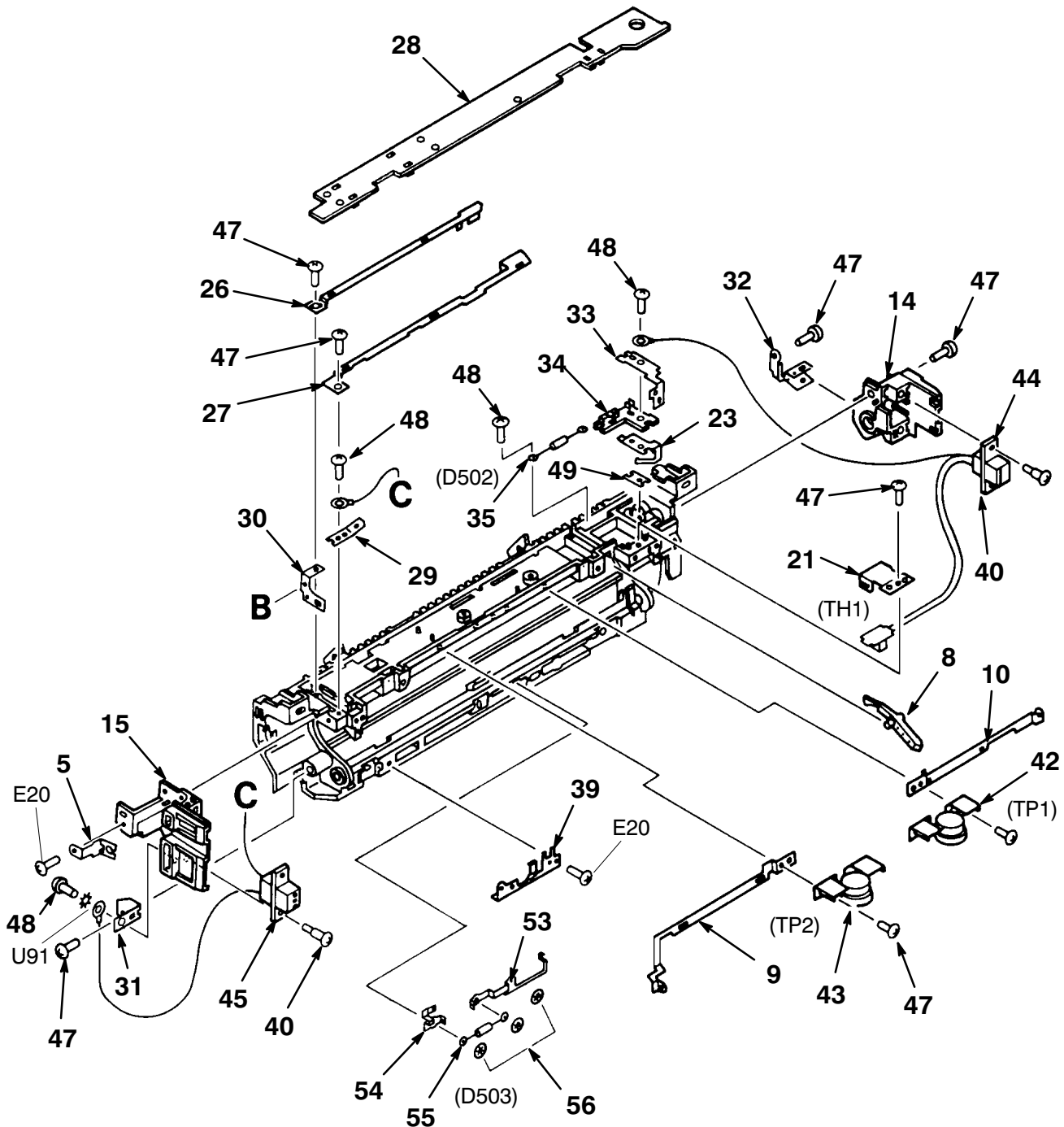

D1100-08A-SC

Figure 8. Fixing Assembly (Sheet 2 of 2)

FIG. & ITEM NO.	DESCRIPTION	VENDOR PART NO.	DEC PART NO.	USED ON CODE	REF FIG NO.
8-	FIXING ASSEMBLY (100/115V) FIXING ASSEMBLY (220/240V)		29-29014-01 29-29020-01	AC BD	1, 3 1, 3
1	*Frame	RF1-3093-000			
1A	**Sheet	RA1-8265-030			
2	*Roller, Upper Fixing	RF1-2505-000			
3	*Roller, Lower Fixing	RA1-7583-000			
4	*Not Used				
5	*Spring, Leaf	RA1-7585-020			
6	*Bushing	RA1-7586-000			
7	*Bushing	RA1-7587-000			
8	*Lever, Delivery Sensor	RA1-7588-000			
9	*Plate, Left Cable	RA1-7589-000			
10	*Plate, Right Cable	RA1-7591-000			
11	*Plate, Right Hook	RA1-7592-000			
12	*Plate, Left Hook *Plate, Left Hook	RA1-7593-000 RA2-0767-000			
13	*Guide, Entrance	RA1-7594-000			
14	*Holder, Right Connector	RA1-7595-000			
15	*Holder, Left Connector	RA1-7596-000			
16	*Washer, Wave	XD9-0079-000			
17	*Plate, Left Lifting	RA1-7598-000			
18	*Plate, Right Lifting	RA1-7599-000			
19	*Eliminator, Static Charge	RA1-7600-000			
20	*Guide, Paper Delivery	RF1-2495-000			
21	*Spring, Thermistor Leaf	RA1-7602-000			
22	*Rod, Latch *Rod, Latch	RA1-7603-000 RA2-0766-000			
23	*Spring, Grounding Leaf	RA1-7604-030			
24	*Spring, Leaf	RF1-3095-000			
25	*Spring, Torsion	RA1-7607-000			
26	*Plate, Cable No. 1	RA1-7608-000			
27	*Plate, Cable No. 2	RA1-7609-000			
28	*Cover, Wire	RA1-7610-000			
29	*Plate, Continuity No. 1	RA1-7617-000			
30	*Plate, Continuity No. 2	RA1-7618-000			
31	*Plate, Continuity No. 3	RA1-7619-000			
32	*Plate, Continuity No. 4	RA1-7620-000			
33	*Plate, Continuity	RA1-8245-000			
34	*Holder, Diode	RA1-8246-000			
35	*Diode, SHV-02	RF1-2494-000			

FIG. & ITEM NO.	DESCRIPTION	VENDOR PART NO.	DEC PART NO.	USED ON CODE	REF FIG NO.
8-					
36	*Gear, 27T/21T	RS1-0287-000			
37	*Spring, Compression	RS1-2241-000			
38	*Screw, M3 x 6 (TP)	XA9-0267-000			
39	*Spring, Leaf	RA1-7828-000			
40	*Screw, Stepped M3	RA1-7636-000			
41	*Heater, Halogen (100/115V)	RH7-4032-000		AC	
	*Heater, Halogen (220/240V)	RH7-4033-000		BD	
42	*Thermoswitch (Cont)	RF1-2483-020			
43	*Thermoswitch (NOC)	RF1-2484-020			
44	*Cable Assembly, Thermistor	RF1-2405-030			
45	*Cable Assembly, AC Connector	RF1-2427-000			
46	*Plate, Blanking	RA1-7510-000			
47	*Screw, M3 x 6	XA9-0233-000			
48	*Screw, M3 x 6	XB2-7300-607			
49	*Sheet, Insulation	RA1-8260-000			
50	*Plate, Insulating	RA1-7730-000			
51	*Screw, Stepped M3	RA1-7803-000			
52	*Spring, Compression	RS1-2255-000			
53	*Plate, Cable	RA1-8264-000			
54	*Plate, Cable	RA1-8264-000			
55	*Diode, AM01A	RH6-3097-000			
56	*Nut, Push	XA9-0134-000			

FIG. & ITEM NO.	DESCRIPTION	VENDOR PART NO.	DEC PART NO.	USED ON CODE	REF FIG NO.
9-	CONTACT ASSEMBLY, H.V.	RG1-1780-000			1, 6
1	*Mount, Plate Contact	RA1-7476-000			
2	*Plate, Drum Contact	RA1-7477-000			
3	*Plate, Contact (T)	RA1-7478-000			
4	*Plate, Contact (P)	RA1-7479-000			
5	*Plate, Contact (D)	RA1-7480-000			
6	*Cable, H.V.	RF1-2382-000			
7	*Lever	RA1-8231-000			
8	*Plate, Contact	RA1-8232-000			

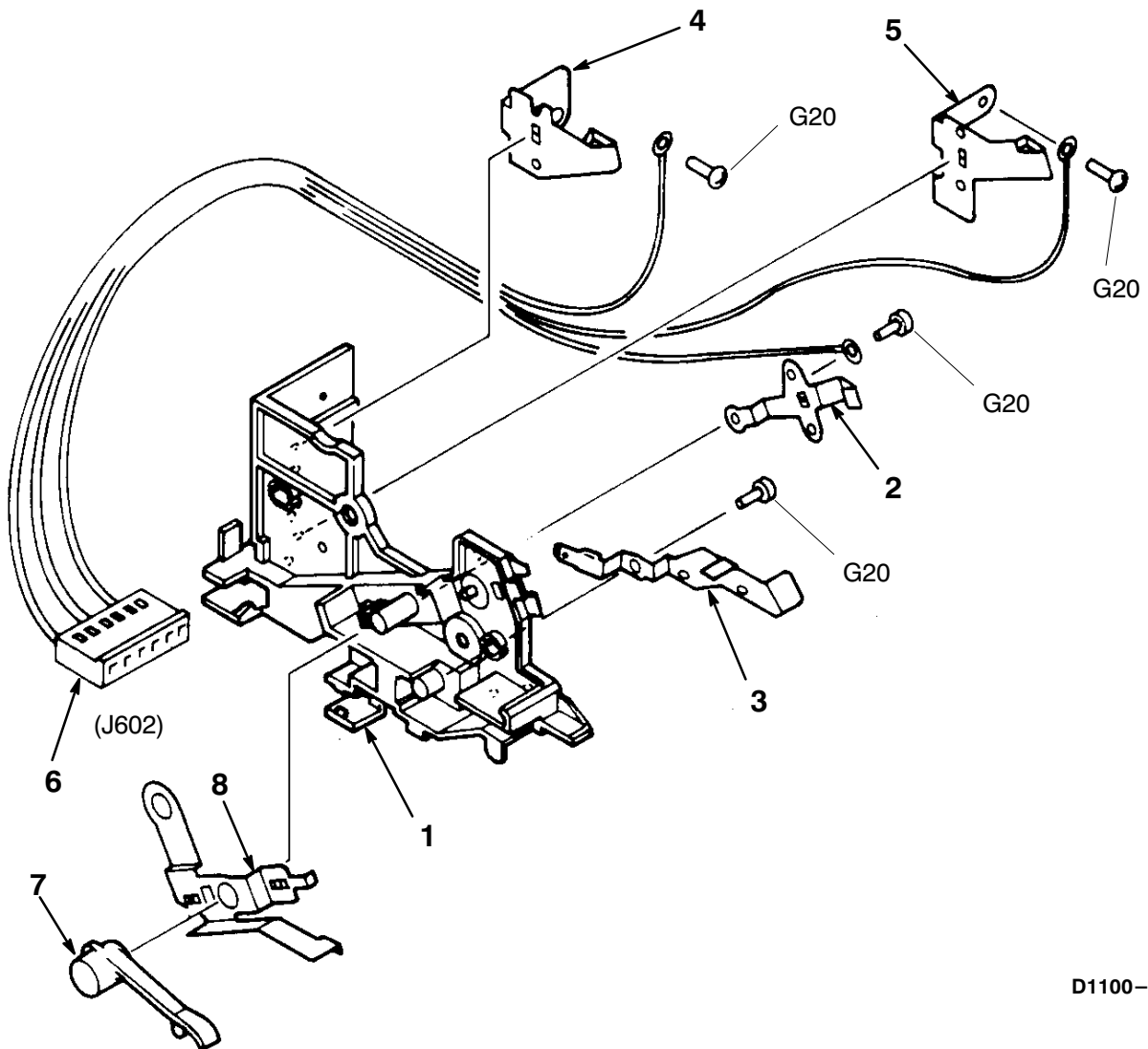

D1100-09-SC

Figure 9. Contact Assembly, H.V

FIG. & ITEM NO.	DESCRIPTION	VENDOR PART NO.	DEC PART NO.	USED ON CODE	REF FIG NO.
10-	DRIVE ASSEMBLY		29-29003-01		1, 6
1	*Plate, Grounding	RA1-7463-000			
2	*Clamp	VT2-0021-001			
3	*Gear, 86T	RS1-0276-000			
4	*Gear, 107T/17T	RS1-0277-000			
5	*Spring, Tension	RS1-2235-000			
6	*Clip	WT2-5059-000			
7	*Plate, Drive	RF1-2393-000			
8	*Screw, M3 x 6 (TP)	XB5-6300-509			

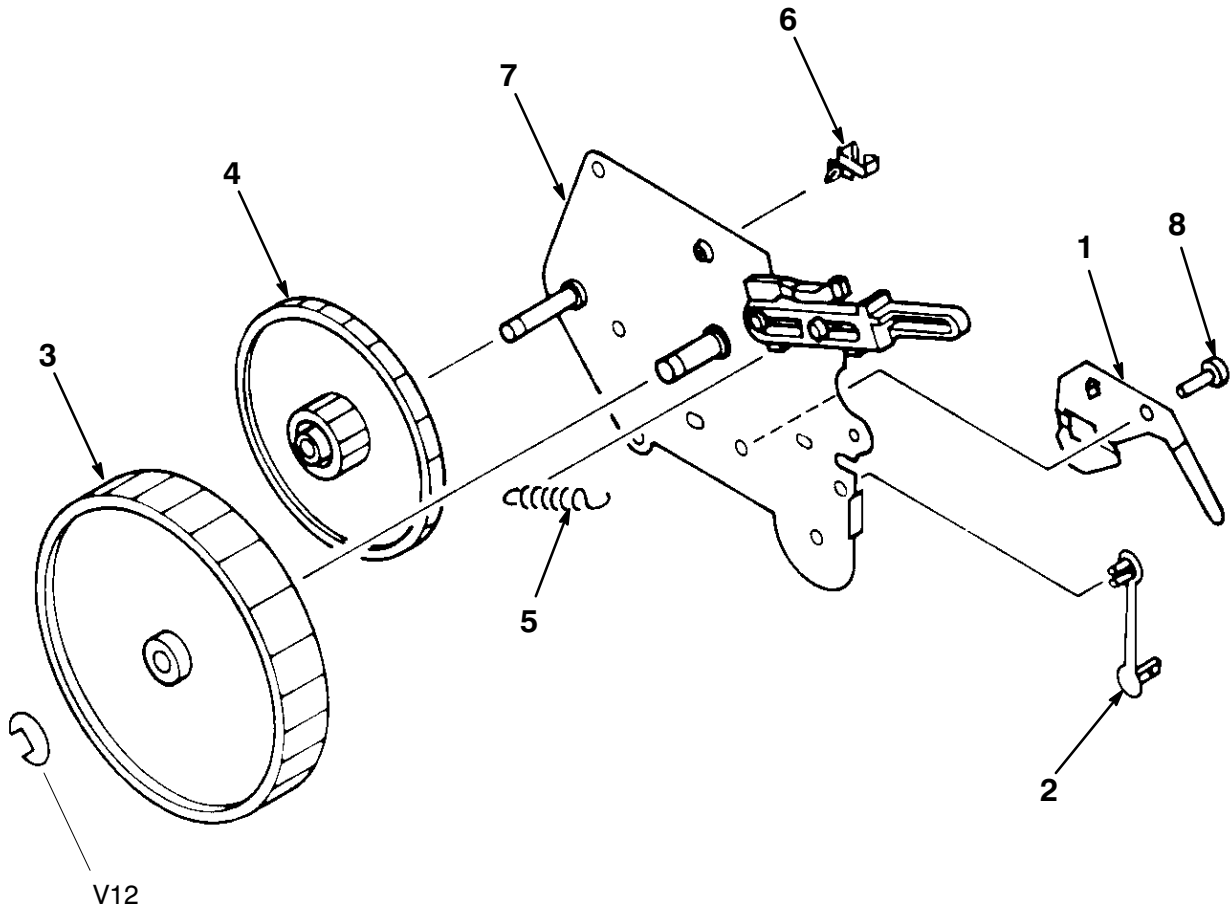

D1100-10-SC

Figure 10. Drive Assembly

FIG. & ITEM NO.	DESCRIPTION	VENDOR PART NO.	DEC PART NO.	USED ON CODE	REF FIG NO.
11-	ROD ASSEMBLY	RG1-1781-000			1, 6
1	*Rod	RF1-2502-000			
2	*Lever, Shutter	RA1-7482-000			
3	*Plate, Retainer	RA1-7483-000			
4	*Rack	RA1-7484-000			
5	*Block, Support Rod	RA1-7485-000			
6	*Spring, Tension	RS1-2238-000			
7	*Spring, Tension	RS1-2239-000			

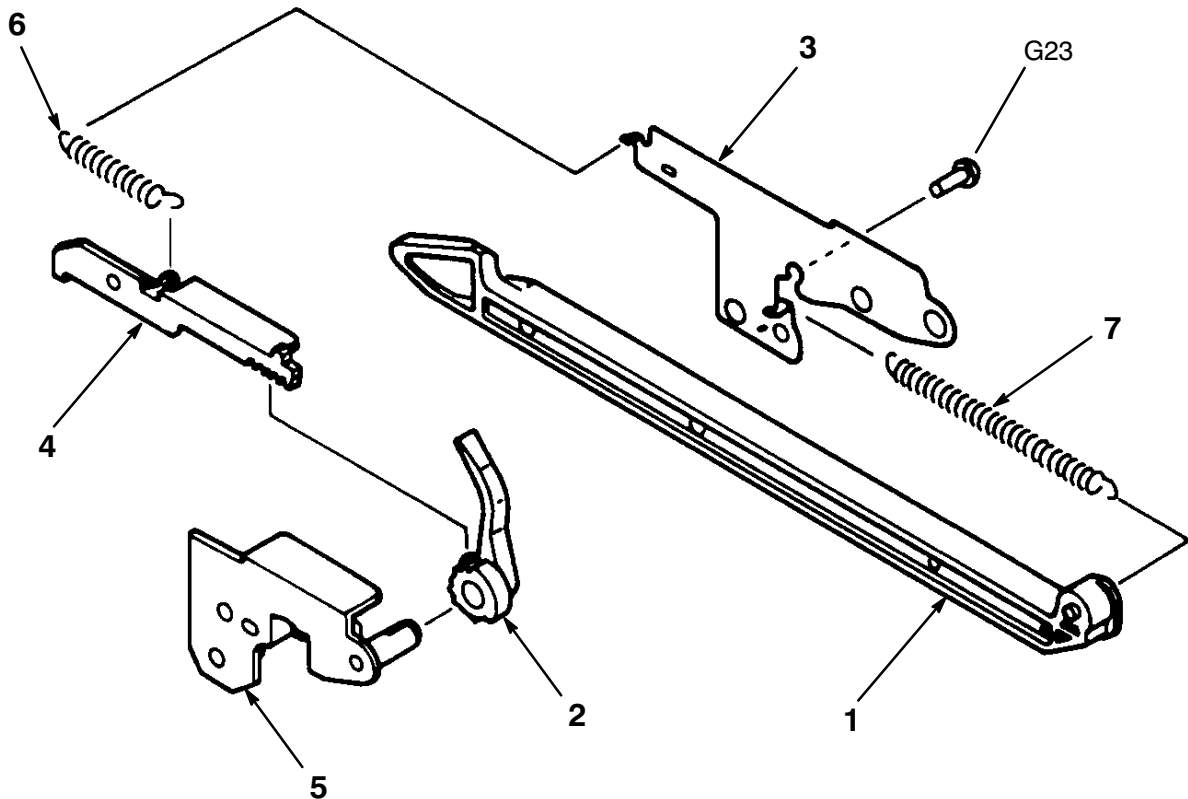

D1100-11-SC

Figure 11. Rod Assembly

FIG. & ITEM NO.	DESCRIPTION	VENDOR PART NO.	DEC PART NO.	USED ON CODE	REF FIG NO.
12-	ROLLER ASSEMBLY, TRAY PICK-UP		29-29005-01		1, 3
1	*Roller, Pick-Up	RA1-7573-000			
2	*Bushing	RA1-7574-000			
3	*Roller	RA1-7575-000			
4	*Ring, Idler	RA1-7578-000			
5	*Cam	RA1-7571-000			
6	*Pin, Dowel	XD9-0108-000			

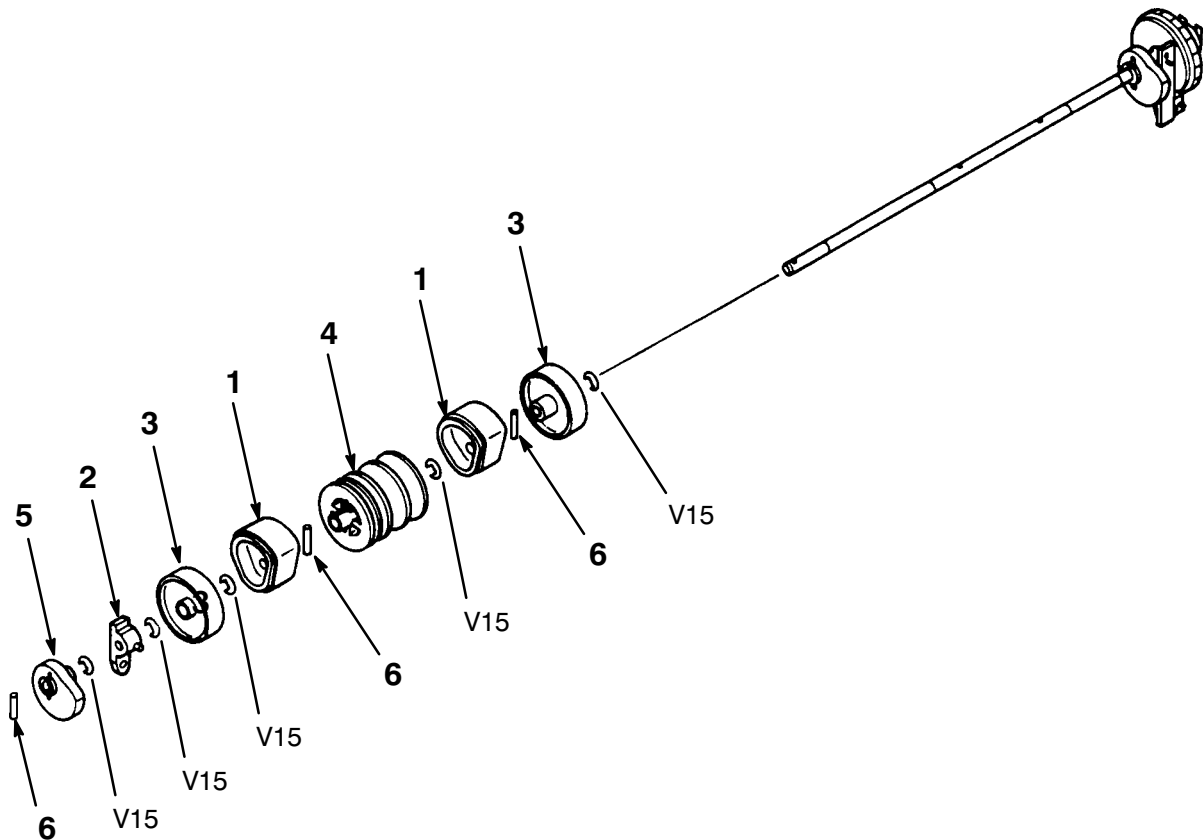

D1100-12-SC

Figure 12. Roller Assembly, Tray Pick-Up

FIG. & ITEM NO.	DESCRIPTION	VENDOR PART NO.	DEC PART NO.	USED ON CODE	REF FIG NO.
13-	FEEDER ASSEMBLY		29-29004-01		1, 6
1	*Arm, Roller Mounting	RA1-7469-000			
2	*Shaft, Drive	RA1-7470-000			
3	*Plate	RA1-7473-000			
4	*Lever, Sensor	RA1-7474-000			
5	*Arm, Auxiliary	RA1-7812-000			
6	*Gear, 25T	RS1-0281-000			
7	*Gear, 15T	RS1-0283-000			
8	*Spring, Tension	RS1-2236-000			
9	*Spring, Compression	RS1-2237-000			
10	*Photo-Interrupter	WG8-0291-000			
11	*Roller, Paper Feed	RF1-2394-000			
12	*Arm, Drive	RF1-2395-000			
13	*Pin, Dowel	XD9-0103-000			

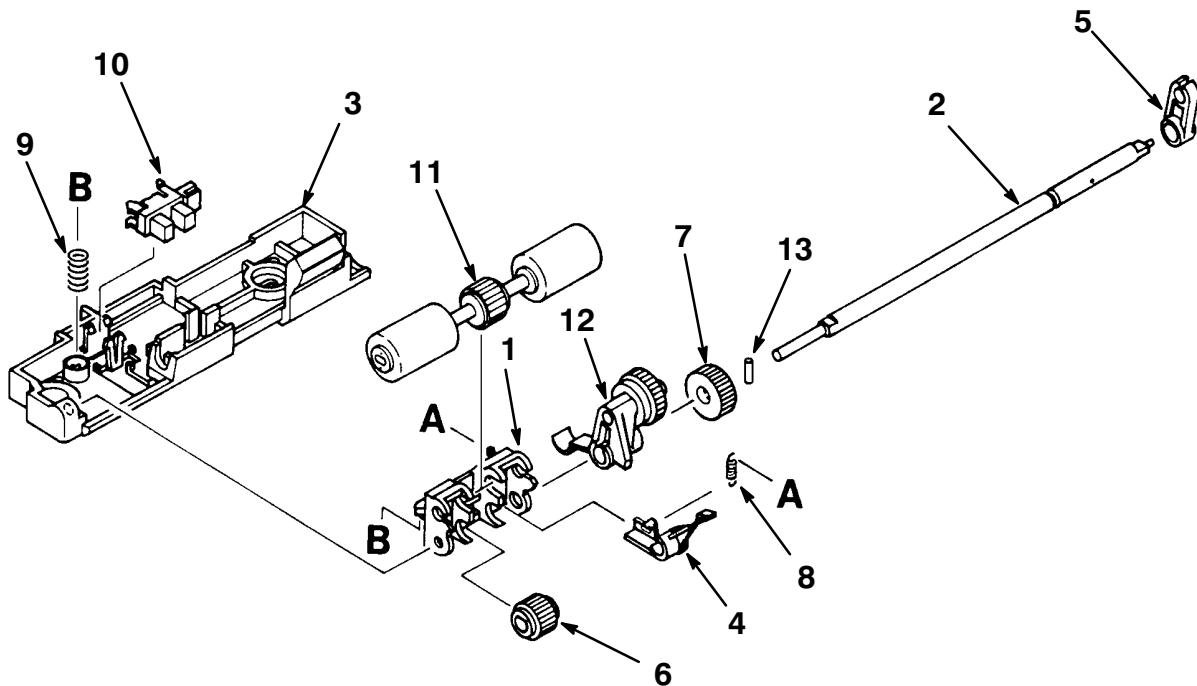

D1100-13-SC

Figure 13. Feeder Assembly

FIG. & ITEM NO.	DESCRIPTION	VENDOR PART NO.	DEC PART NO.	USED ON CODE	REF FIG NO.
14-	DELIVERY ASSEMBLY, FACE-DOWN	RG1-1791-070			1,3
1	*Spring, Leaf	RA1-7569-000			
2	*Cover, FD	RA1-7613-000			
3	*Spring, Tension	RS1-2248-000			
4	*Roller, Delivery	RA1-7708-040			
5	*Support, Right Roller	RA1-7709-000			
6	*Support, Left Roller	RA1-7710-000			
7	*Gear, 13T	RS1-0303-000			
8	*Mount, Left FD Cover	RA1-7616-000			
9	*Pin, Dowel	XD9-0111-000			

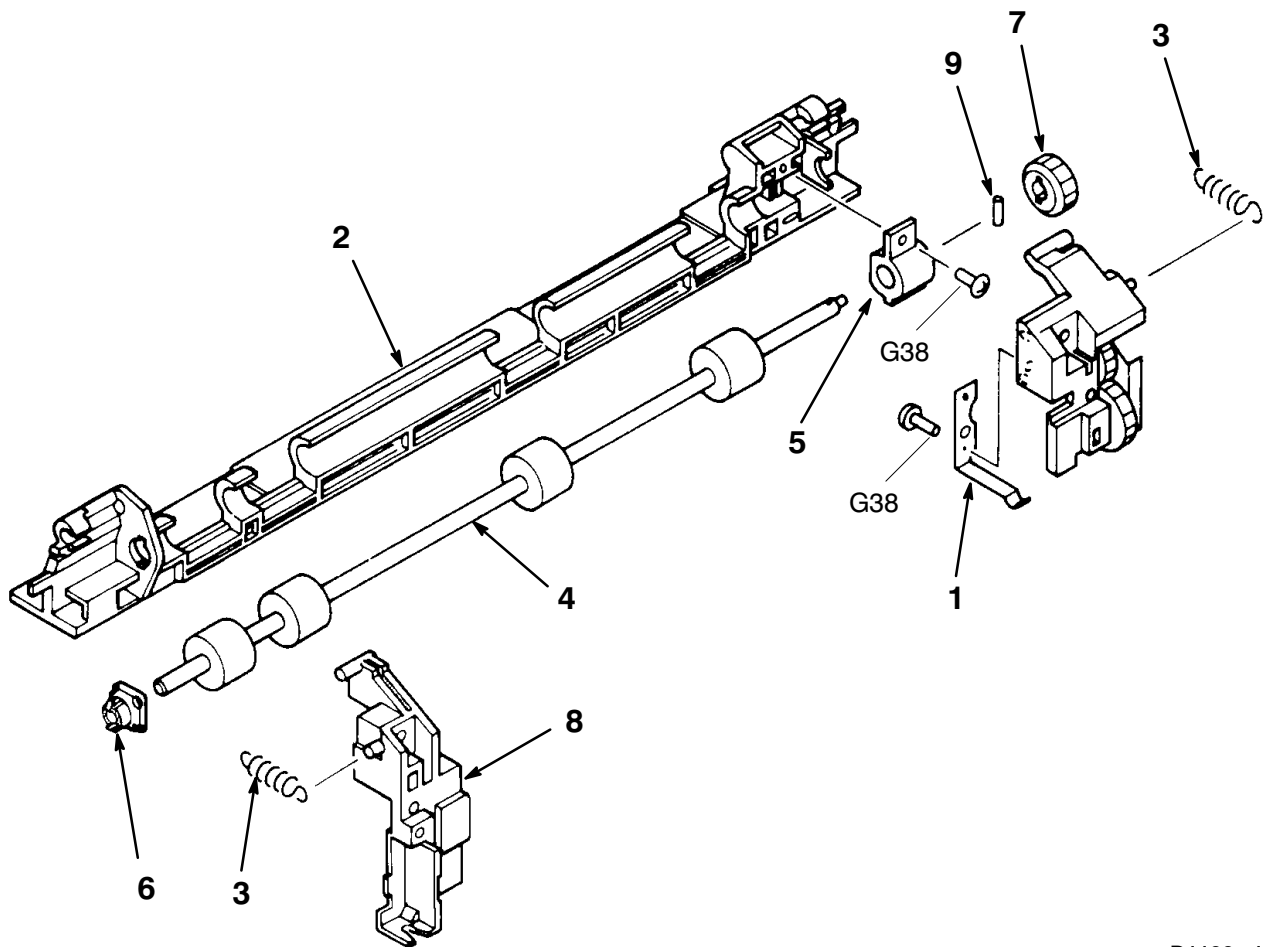

D1100-14-SC

Figure 14. Delivery Assembly, Face-Down

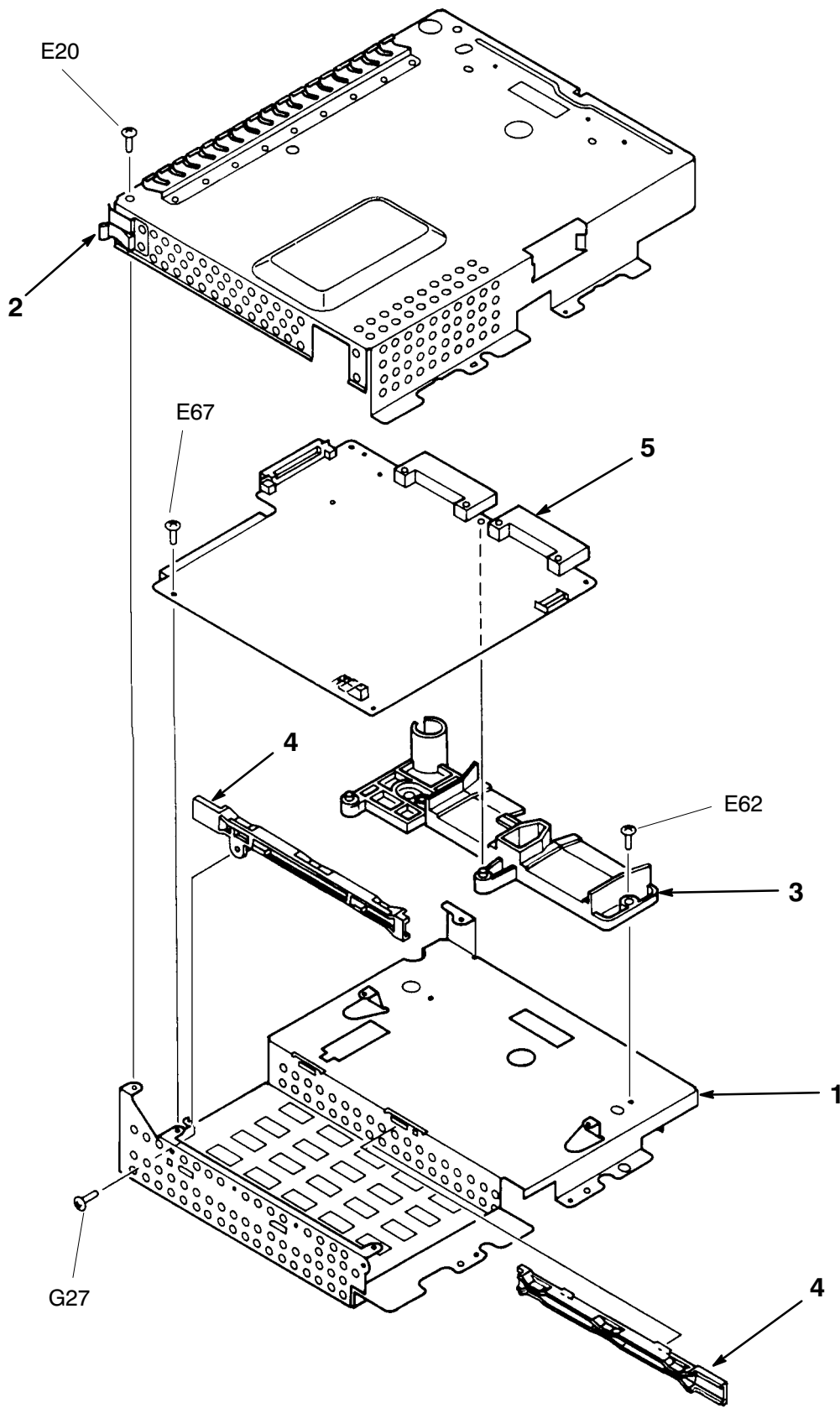

D1100-15-SC

Figure 15. Controller Assembly, Video

FIG. & ITEM NO.	DESCRIPTION	VENDOR PART NO.	DEC PART NO.	USED ON CODE	REF FIG NO.
15-	CONTROLLER ASSEMBLY, VIDEO	RG1-2633-000			1
1	*Mount, Module	RA1-7538-000			
2	*Cover, Shield	RA1-7540-000			
3	*Guide, Font	RA1-7542-000			
4	*Rail	RA1-7544-000			
5	*Module Assy, Video Controller (DEClaser 1100)		29-29018-01	AB	
	*Module Assy, Video Controller (DEClaser 1152)		29-30382-01	CD	
6	*EEPROM, Serial (Not Shown)		21-23613-04	CD	
	<p>NOTE: Item 5 shown for reference only, not part of this assembly.</p>				

PARTS LIST

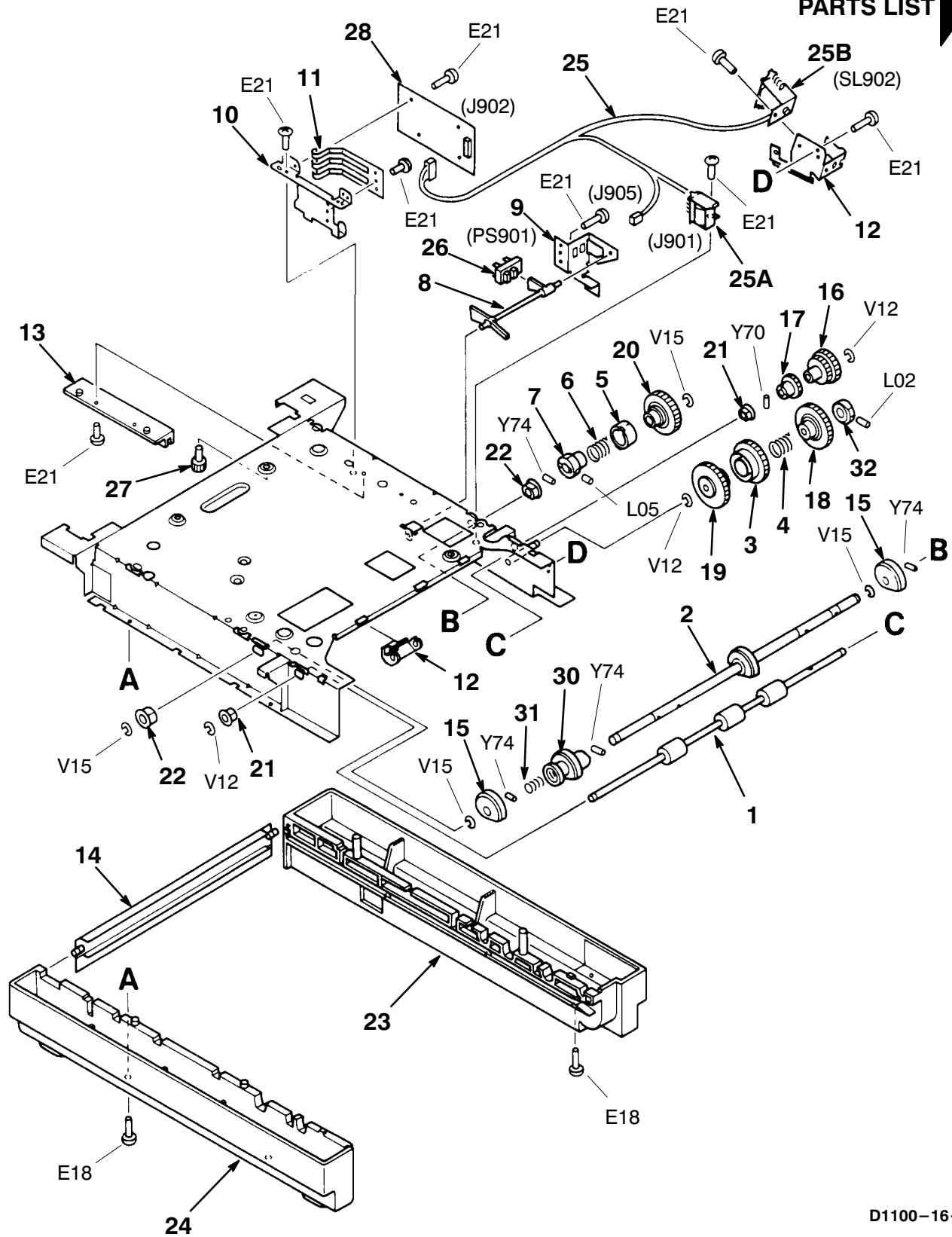

D1100-16-SC

Figure 16. Feeder Assembly, Cassette

FIG.& ITEM NO.	DESCRIPTION	VENDOR PART NO.	DEC PART NO.	USED ON CODE	REF FIG NO.
16-	FEEDER ASSEMBLY, CASSETTE	N/A			1
1	*Shaft, Feed Roller		29-28995-01		
2	*Shaft, Pick-Up Roller		29-28996-01		
3	*Ring (A), Ratchet	RA1-7656-000			
4	*Spring (A), Clutch	RA1-7657-000			
5	*Ring (B), Ratchet	RA1-7658-000			
6	*Spring (B), Clutch	RA1-7659-000			
7	*Ring	RA1-7660-000			
8	*Arm, Sensing	RA1-7661-000			
9	*Mount, Sensor	RA1-7662-000			
10	*Mount, (PCB) Module	RA1-7663-020			
11	*Spring, Leaf	RA1-7664-000			
12	*Mount, Solenoid	RA1-7665-000			
13	*Guide, Cassette	RA1-7666-000			
14	*Cover, Stop	RA2-0886-000			
15	*Roller, Pick-Up	RA1-7674-000			
16	*Gear, 33T/19T	RS1-0295-000			
17	*Gear, 17T	RS1-0296-000			
18	*Gear, 37T	RS1-0297-000			
19	*Gear, 39T	RS1-0298-000			
20	*Gear, 34T	RS1-0299-000			
21	*Bushing	RS1-1053-000			
22	*Bushing	RS1-1054-000			
23	*Cover, Right Feeder	RF1-3172-000			
24	*Cover, Left Feeder	RF1-3178-000			
25	*CABLE ASSEMBLY,	RF1-2406-000			
25A	**Solenoid, DC 24V	RH7-5025-000			
25B	**Solenoid, DC 24V	RH7-5026-000			
26	*Photo-Interrupter	WG8-0291-000			
27	*Screw, M3	XA9-0494-000			
28	*Module Assembly, Cassette Feeder		29-28998-01		
29	*Guide, Roller	RA1-7821-000			
30	*Roller, Pick-Up	RA1-7824-000			
31	*Spring, Compression	RS1-2254-000			
32	*Collar, Retaining	RS1-6047-020			

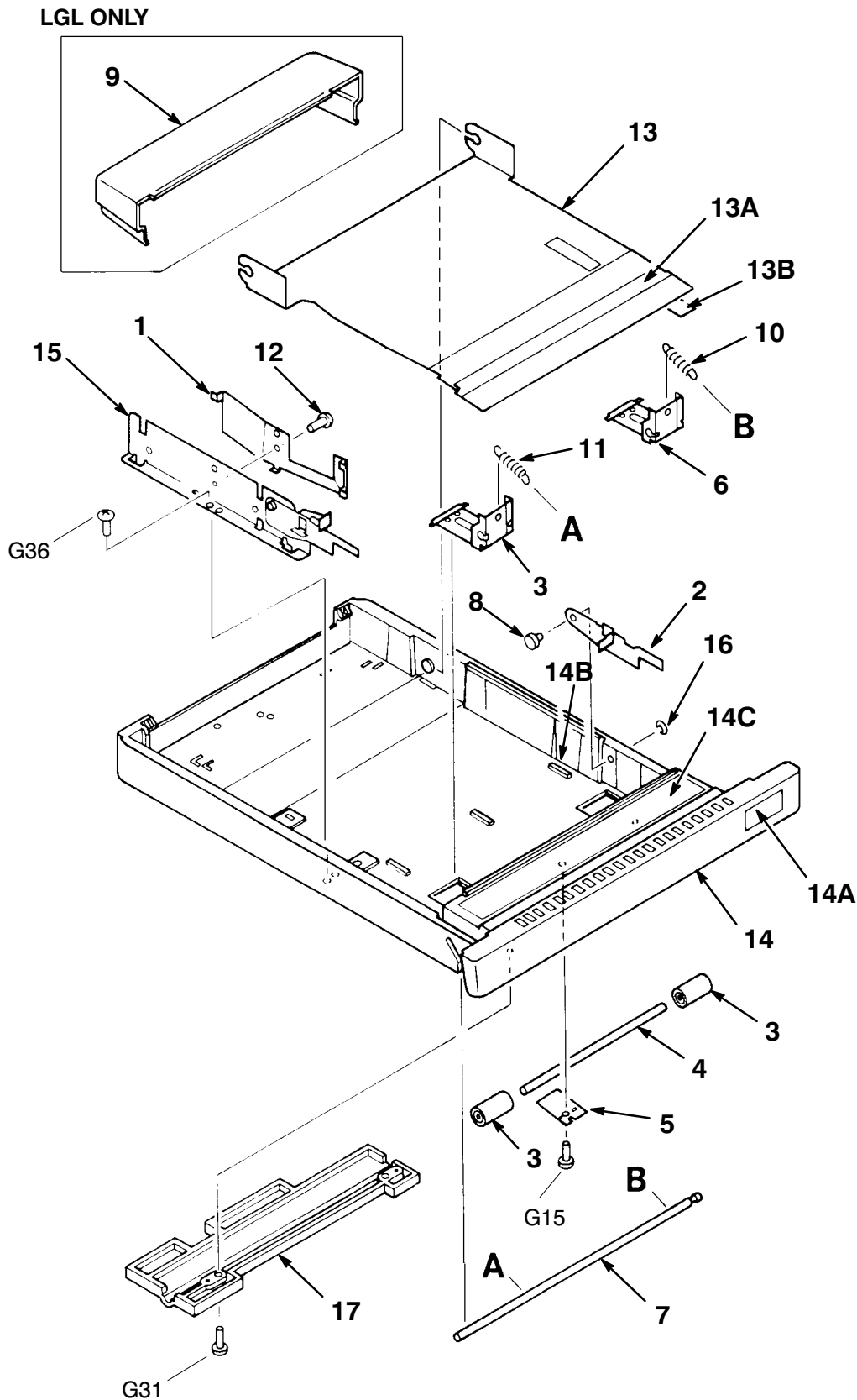

D1100-17-SC

Figure 17. Cassette Assembly (A4, LGL)

FIG. & ITEM NO.	DESCRIPTION	VENDOR PART NO.	DEC PART NO.	USED ON CODE	REF FIG NO.
17-	CASSETTE ASSEMBLY (A4, LGL)	N/A			1
1	*Spring, Leaf	RA1-7696-000			
2	*Plate, Claw	RA1-7698-000			
3	*Roller	RA1-7699-000			
4	*Rod, Roller	RA1-7700-000			
5	*Spring, Leaf	RA1-7701-000			
6	*Plate	RA1-7702-000			
7	*Rod	RA1-7703-000			
8	*Pivot	RA1-7704-000			
9	*Cover (for LGL only)	RA2-0897-000			
10	*Spring, Tension	RS1-2251-000			
11	*Spring, Tension	RS1-2252-000			
12	*Screw, Machine Truss Head M3 x 4	FB1-2267-000			
13	*PLATE, PAPER LIFTING(A4)	RF1-2422-000			
	*PLATE, PAPER LIFTING (LGL)	RF1-2424-000			
13A	**Sheet, Friction (A4)	RA1-7689-000			
	**Sheet, Friction (LGL)	RA1-7691-000			
13B	**Sheet	RA1-7706-000			
14	*CASSETTE BODY (LGL)	RF1-3173-000			
	*CASSETTE BODY (A4)	RF1-3174-000			
14A	**Label, Size (A4)	RA2-0893-000			
	**Label, Size (LGL)	RA2-0895-000			
14B	**Label	RS1-8842-000			
14C	**Label	RS1-8843-000			
15	*Plate, Size	RF1-2426-000			
16	*Ring, E	XD9-0101-000			
17	*Cover, Cassette	RA1-8241-000			

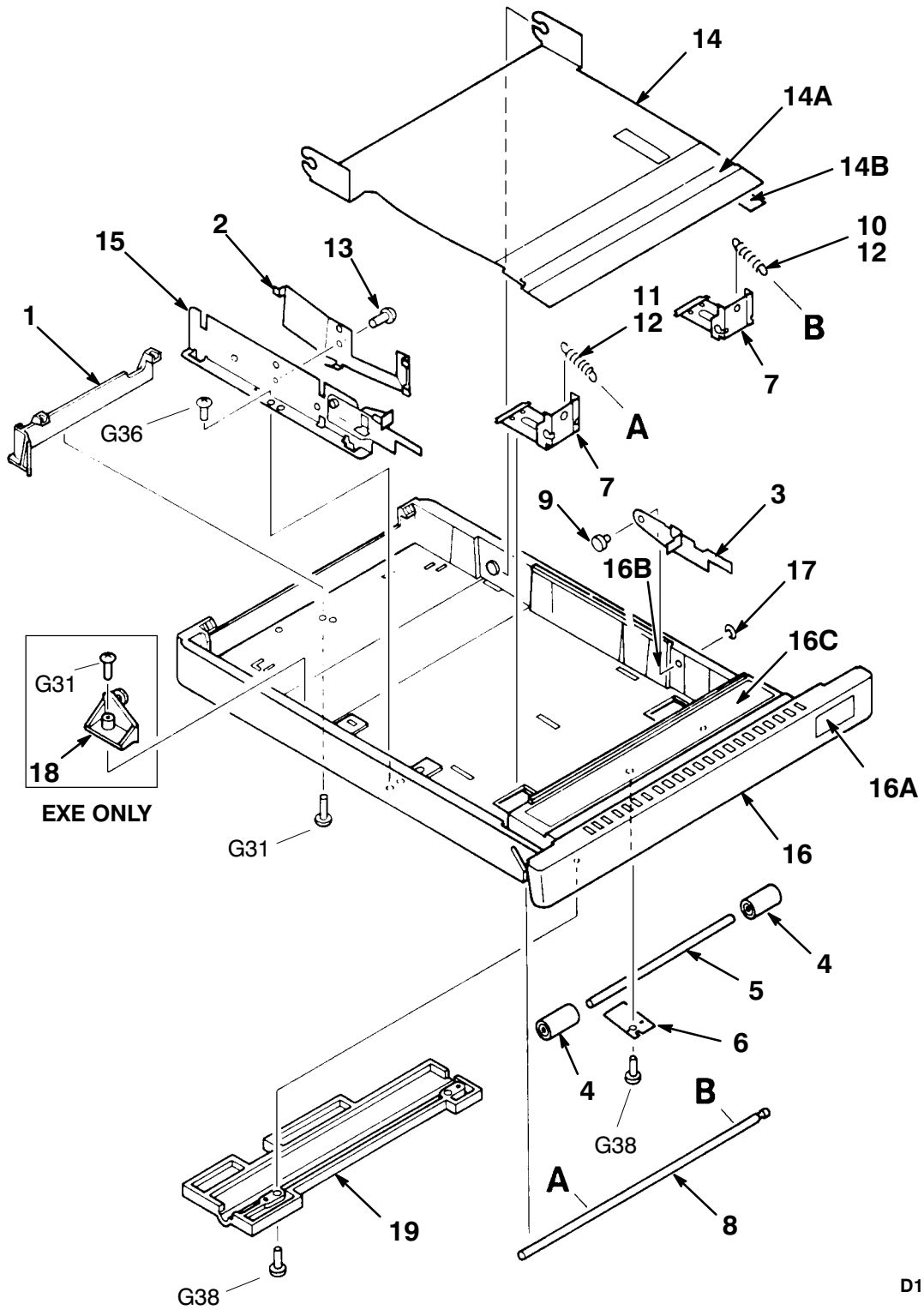

D1100-18-SC

Figure 18. Cassette Assembly (LTR,EXE)

FIG. & ITEM NO.	DESCRIPTION	VENDOR PART NO.	DEC PART NO.	USED ON CODE	REF FIG NO.
18-	CASSETTE ASSEMBLY (LTR, EXE)	N/A			1
1	*Plate, Length Adjustment	RA1-7693-000			
2	*Spring, Leaf	RA1-7696-000			
3	*Plate, Claw	RA1-7698-000			
4	*Roller	RA1-7699-000			
5	*Rod, Roller	RA1-7700-000			
6	*Spring, Leaf	RA1-7701-000			
7	*Plate	RA1-7702-000			
8	*Rod	RA1-7703-000			
9	*Pivot	RA1-7704-000			
10	*Spring, Tension (LTR)	RS1-2251-000			
11	*Spring, Tension (LTR)	RS1-2252-000			
12	*Spring, Tension (EXE)	RS1-2247-000			
13	*Screw, Machine Truss Head M3 x 4	FB1-2267-000			
14	*PLATE, PAPER LIFTING (LTR)	RF1-2424-000			
	*PLATE, PAPER LIFTING (EXE)	RF1-2425-000			
14A	**Sheet, Friction (LTR)	RA1-7691-000			
	**Sheet, Friction (EXE)	RA1-7692-000			
14B	**Sheet	RA1-7706-000			
15	*Plate, Size	RF1-2426-000			
16	*BODY, CASSETTE (LTR)	RF1-2436-000			
	*BODY, CASSETTE (EXE)	RF1-2438-000			
16A	**Label, Size (LTR)	RS1-8797-000			
	**Label, Size (EXE)	RS1-8799-000			
16B	**Label	RS1-8805-000			
16C	**Label	RS1-8836-000			
17	*Ring, E	XD9-0101-000			
18	*Support, Plate (EXE)	RA1-7823-000			
19	*Cover, Cassette	RA1-8241-000			

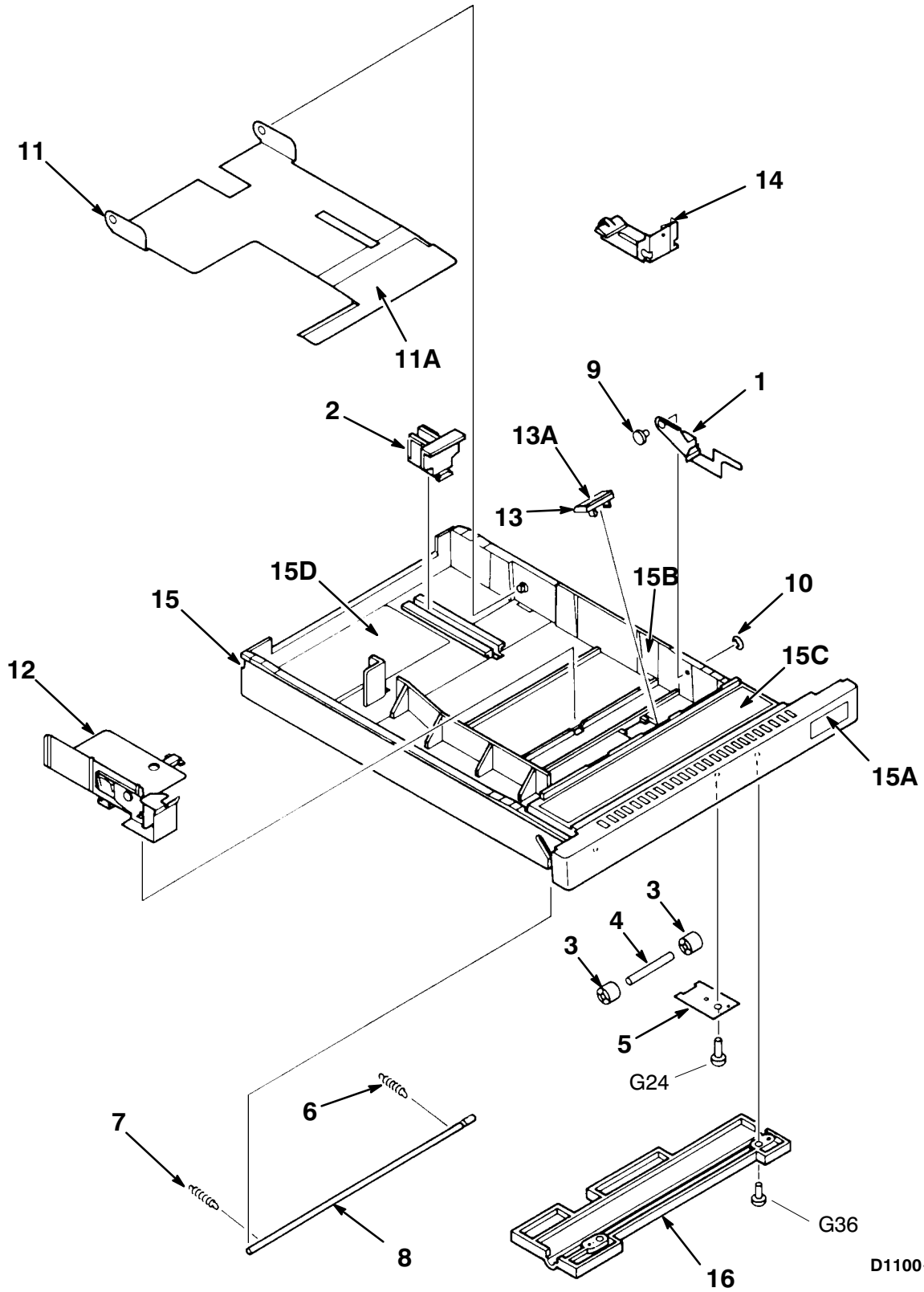

D1100-19-SC

Figure 19. Cassette Assembly (Envelope)

FIG. & ITEM NO.	DESCRIPTION	VENDOR PART NO.	DEC PART NO.	USED ON CODE	REF FIG NO.
19-	CASSETTE ASSEMBLY (ENVELOPE)	N/A			1
1	*Plate, Right Hold-down Tab	RA1-8358-000			
2	*Plate, End Length Adjustment	RA1-8363-000			
3	*Roller	RA1-8366-000			
4	*Rod, Roller	RA1-8367-000			
5	*Spring, Leaf	RA1-8368-000			
6	*Spring, Tension	RS1-2265-000			
7	*Spring, Tension	RS1-2266-000			
8	*Rod	RA1-7703-000			
9	*Pivot	RA1-7704-000			
10	*Ring, E	XD9-0101-000			
11	*PLATE, PAPER LIFTING	RF1-2597-000			
11A	**Strip, Friction	RA1-8357-000			
12	*Plate, End Width Adjustment	RF1-2598-000			
13	*PAD ASSEMBLY	RF1-2599-000			
13A	**Pad	RA1-8365-000			
14	*Plate	RF1-2600-000			
15	*CASSETTE BODY	RF1-2602-000			
15A	**Label, Size	RS1-8805-000			
15B	**Label	RS1-8805-000			
15C	**Label	RS1-8837-000			
15D	**Label, Caution	RS1-8839-000			
16	*Cover, Cassette	RA1-8241-000			

Ω

LIST OF STANDARD FASTENERS

THIS PAGE INTENTIONALLY LEFT BLANK

LIST OF STANDARD FASTENERS

I. SCREWS	A-2
A. Machine Screws (for precision use)	A-3
B. Pan Head Machine Screws	A-3
E. Binding Head Machine Screws	A-4
F. Flat Head Machine Screws	A-5
G. Self-Tapping Screws	A-5, A-6
H. Pan Head Machine Screws with Captive Spring Washer	A-6
K. Washer Head Machine Screws	A-6, A-7
L. Hex Socket Setscrews and Socket Head Cap Screws	A-7
II. NUTS	A-8
M. Hexagon Nuts	A-8
III. WASHERS AND SHIM WASHERS	A-8
N,S,T. Shim Washers	A-9, A-10
U. Plain Washers, Spring Washers, & Toothed Lock Washers	A-11
IV. RETAINING RINGS	A-11
V. E Rings	A-11
W. Grip Rings	A-12
X. C Rings	A-12
V. PINS	A-13
Y. Spring and Dowel Pins	A-13
VI. SPACERS	A-13
Z. Spacers	A-14

LIST OF STANDARD FASTENERS

I. SCREWS

How to read Part Numbers

Screws (except socket head cap screws)

X B 1 – 2 4 0 0 – 6 0 9

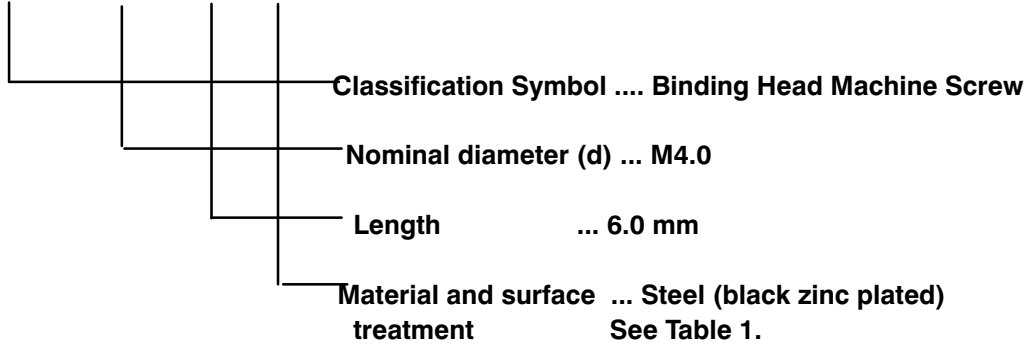

Socket head cap screws

X B 7 – 1 0 8 0 – 4 0 9

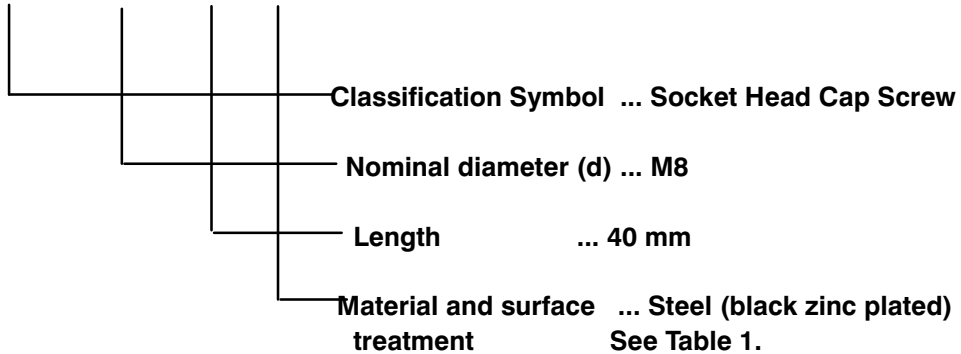

Material and Surface Treatment

No.	Material	Surface Treatment	Color
1	Stainless	Blackened	Black
2		Without surface treatment	White
3	Brass	Nickle plated	White
4		Black nickle plated	Black
5	Steel	Zinc plated	Yellow
6		Nickle and chrome plated	White
7		Nickle plated	White
8		Phosphated	Black
9		Black zinc plated	Black

Table 1

A. MACHINE SCREWS (FOR PRECISION USE)

Pan Head Machine Screws

<u>Call out No.</u>	<u>Part Number</u>
A22	XA1-1200-307
A26	XA1-1200-409
A28	XA1-1200-509
A30	XA1-1200-607
A33	XA1-1200-809
A46	XA1-1261-605
A47	XA1-1261-609
A61	XA1-6200-306

Flat Head Machine Screws

<u>Call out No.</u>	<u>Part Number</u>
A82	XA1-3200-407
A85	XA1-3300-609

B. PAN HEAD MACHINE SCREWS

<u>Call out No.</u>	<u>Part Number</u>	<u>Call out No.</u>	<u>Part Number</u>
B24	XB1-1300-407	B51	XB1-1400-602
B25	XB1-1300-509	B53	XB1-1400-604
B27	XB1-1300-606	B54	XB1-1400-609
B29	XB1-1300-609	B56	XB1-1400-807
B32	XB1-1300-807	B57	XB1-1400-809
B33	XB1-1300-809	B58	XB1-1401-009
B34	XB1-1301-007	B60	XB1-1401-207
B36	XB1-1301-009	B61	XB1-1401-609
B39	XB1-1301-209	B63	XB1-1402-503
B42	XB1-1301-609	B64	XB1-1403-009
B43	XB1-1302-009	B82	XB1-1501-209
B44	XB1-1302-507		

E. BINDING HEAD MACHINE SCREWS

<u>Call out No.</u>	<u>Part Number</u>	<u>Call out No.</u>	<u>Part Number</u>	<u>Call out No.</u>	<u>Part Number</u>
E01	XB1-2200-403	E30	XB1-2301-202	E63	XB1-2401-002
E02	XB1-2200-809	E31	XB1-2301-204	E64	XB1-2401-004
E03	XB1-2200-407	E32	XB1-2301-209	E65	XB1-2401-006
E04	XB1-2200-409	E33	XB1-2301-603	E66	XB1-2401-007
E05	XB1-2201-009	E34	XB1-2301-604	E67	XB1-2401-009
E06	XB1-2300-403	E37	XB1-2301-609	E68	XB1-2401-203
E07	XB1-2300-404	E38	XB1-2302-003	E69	XB1-2401-204
E08	XB1-2300-406	E39	XB1-2302-005	E70	XB1-2401-206
E09	XB1-2300-407	E41	XB1-2302-009	E71	XB1-2401-207
E10	XB1-2300-409	E42	XB1-2302-503	E72	XB1-2401-209
E11	XB1-2300-502	E44	XB1-2302-509	E73	XB1-2401-602
E12	XB1-2300-503	E45	XB1-2303-003	E74	XB1-2401-604
E13	XB1-2300-504	E46	XB1-2303-009	E75	XB1-2401-606
E14	XB1-2300-506	E47	XB1-2303-509	E76	XB1-2401-609
E15	XB1-2300-509	E48	XB1-2304-507	E77	XB1-2401-605
E16	XB1-2300-601	E49	XB1-2400-405	E78	XB1-2402-006
E17	XB1-2300-604	E50	XB1-2400-409	E79	XB1-2402-009
E18	XB1-2300-603	E51	XB1-2400-506	E80	XB1-2402-005
E19	XB1-2300-606	E52	XB1-2400-509	E81	XB1-2402-509
E20	XB1-2300-607	E53	XB1-2400-602	E83	XB1-2403-009
E21	XB1-2300-609	E54	XB1-2400-603	E84	XB1-2403-505
E22	XB1-2300-801	E55	XB1-2400-604	E85	XB1-2404-009
E23	XB1-2300-804	E56	XB1-2400-606	E86	XB1-2404-507
E24	XB1-2300-805	E57	XB1-2400-607	E90	XB1-2500-609
E25	XB1-2300-807	E58	XB1-2400-609	E91	XB1-2500-809
E26	XB1-2300-809	E59	XB1-2400-605	E93	XB1-2501-009
E27	XB1-2300-605	E60	XB1-2400-804	E94	XB1-2501-609
E28	XB1-2301-005	E61	XB1-2400-806	E95	XB1-2502-009
E29	XB1-2301-009	E62	XB1-2400-809	E96	XB1-2502-509
				E98	XB1-2504-009
				E99	XB1-2505-009

F. FLAT HEAD MACHINE SCREWS

<u>Call out No.</u>	<u>Part Number</u>	<u>Call out No.</u>	<u>Part Number</u>
F16	XB1-3200-609	F35	XB1-3301-209
F20	XB1-3300-409	F39	XB1-3302-505
F21	XB1-3300-502	F61	XB1-3400-605
F22	XB1-3300-509	F62	XB1-3400-609
F23	XB1-3300-601	F64	XB1-3400-804
F24	XB1-3300-604	F65	XB1-3400-806
F25	XB1-3300-606	F66	XB1-3400-809
F26	XB1-3300-609	F67	XB1-3401-006
F27	XB1-3300-802	F68	XB1-3401-009
F28	XB1-3300-806	F69	XB1-3401-206
F29	XB1-3300-807	F70	XB1-3402-005
F30	XB1-3300-809	F71	XB1-3402-509
F31	XB1-3301-002		
F32	XB1-3301-006		
F33	XB1-3301-009		
F34	XB1-3301-202		

G. SELF-TAPPING SCREWS

Pan head self-tapping screws

<u>Call out No.</u>	<u>Part Number</u>	<u>Call out No.</u>	<u>Part Number</u>
G11	XB4-1300-509	G23	XB4-7401-009
G12	XB4-1300-609	G24	XB4-7400-609
G13	XB4-1300-809	G25	XB4-7400-809
G14	XB4-1301-009	G26	XB4-7400-209
G15	XB4-7300-607	G27	XB4-7401-607
G16	XB4-7300-609	G28	XB4-7505-507
G17	XB4-7300-809	G29	XB4-7401-207
G18	XB4-7301-009	G30	XB4-7401-009
G19	XB4-7301-209	G32	XB4-7401-007
G20	XB4-7300-807	G33	XB4-7601-007
G21	XB3-1400-809	G34	XB4-7400-605
G22	XB4-6200-507	G35	XB4-7300-509
		G36	XB4-7400-607
		G37	XB4-7400-807
		G38	XB4-7400-807

LIST OF STANDARD FASTENERS

G. SELF-TAPPING SCREWS (CONTINUED)

Binding head self-tapping screws

<u>Call out No.</u>	<u>Part Number</u>	<u>Call out No.</u>	<u>Part Number</u>
G31	XB3-2260-509	G54	XB3-2401-209
G41	XB3-2300-609	G55	XB3-2402-009
G42	XB3-2300-809	G56	XB3-2401-005
G43	XB3-2301-009	G61	XB5-2300-609
G44	XB3-2302-009	G65	XB3-2400-609
G51	XB3-2400-609	G67	XB3-2400-809
G52	XB3-2400-809	G69	XB3-2401-209
G53	XB3-2401-009		

Flat head self-tapping screws

<u>Call out No.</u>	<u>Part Number</u>	<u>Call out No.</u>	<u>Part Number</u>
G71	XB3-3300-609	G82	XB3-3401-209
G72	XB3-3300-809	G97	XB4-8260-807
G81	XB3-3400-809		

H. PAN HEAD MACHINE SCREWS WITH CAPTIVE SPRING WASHER

<u>Call out No.</u>	<u>Part Number</u>	<u>Call out No.</u>	<u>Part Number</u>
H42	XB6-6300-505	H63	XB6-6401-005
H43	XB6-6300-605	H64	XB6-6401-205
H44	XB6-6300-805	H65	XB6-6401-605
H45	XB6-6301-005	H66	XB6-6402-005
H46	XB6-6301-205	H81	XB6-6500-805
H47	XB6-6301-605	H82	XB6-6501-005
H48	XB6-6302-005	H83	XB6-6501-205
H61	XB6-6400-605	H85	XB6-6502-005
H62	XB6-6400-805		

K. WASHER HEAD MACHINE SCREWS

<u>Call out No.</u>	<u>Part Number</u>	<u>Call out No.</u>	<u>Part Number</u>
K02	XB6-7201-009	K60	XB6-7400-605
K10	XB5-6400-609	K61	XB6-7400-409
K20	XB6-7260-409	K62	XB6-7400-509
K21	XB6-7260-509	K63	XB6-7400-609
K39	XB6-7300-407	K64	XB6-7400-809

LIST OF STANDARD FASTENERS

K. WASHER HEAD MACHINE SCREWS (continued)

<u>Call out No.</u>	<u>Part Number</u>	<u>Call out No.</u>	<u>Part Number</u>
K40	XB6-7300-305	K65	XB6-7401-009
K41	XB5-7300-409	K66	XB6-7401-209
K42	XB6-7300-509	K67	XB6-7401-609
K43	XB6-7300-609	K68	XB6-7402-009
K44	XB6-7300-809	K69	XB6-7402-509
K45	XB6-7301-009	K81	XB6-7500-609
K46	XB6-7301-209	K82	XB6-7500-809
K47	XB6-7301-609	K83	XB6-7501-009
K48	XB6-7302-009	K84	XB6-7501-609
K49	XB6-7300-607	K85	XB6-7502-009
K50	XB6-7301-005		

L. HEX SOCKET SETSCREWS AND SOCKET HEAD CAP SCREWS

Hex socket setscrews

<u>Call out No.</u>	<u>Part Number</u>	<u>Call out No.</u>	<u>Part Number</u>
L01	XB6-1400-608	L09	XB6-2400-608
L02	XB6-2300-408	L10	XB6-2400-808
L03	XB6-2300-508	L11	XB6-2401-008
L04	XB6-2300-608	L12	XB6-2401-208
L05	XB6-2300-409	L14	XB6-2500-508
L07	XB6-2400-408	L16	XB6-2500-808
L08	XB6-2400-508	L23	XB6-2601-008

Socket head cap screws

<u>Call out No.</u>	<u>Part Number</u>	<u>Call out No.</u>	<u>Part Number</u>
L52	XB7-1030-069	L67	XB7-1040-209
L53	XB7-1030-089	L68	XB7-1040-259
L54	XB7-1030-109	L72	XB7-1050-109
L55	XB7-1030-129	L73	XB7-1050-129
L56	XB7-1030-169	L74	XB7-1050-169
L58	XB7-1030-259	L75	XB7-1050-209
L62	XB7-1040-069	L77	XB7-1050-309
L63	XB7-1040-089	L81	XB7-1060-109
L64	XB7-1040-109	L82	XB7-1060-129
L65	XB7-1040-129	L83	XB7-1060-169
L66	XB7-1040-169	L86	XB7-1060-309
		L91	XB7-1080-129
		L93	XB7-1082-509
		L92	XB7-1080-169
		L95	XB7-1100-209

LIST OF STANDARD FASTENERS

II. NUTS

M. HEXAGON NUTS

<u>Call out No.</u>	<u>Part Number(Class 1)</u>	<u>Call out No.</u>	<u>Part Number (Class 3)</u>
M03	XB7-2100-309	M53	XB7-2200-309
M04	XB7-2100-409	M54	XB7-2200-409
M05	XB7-2100-509	M55	XB7-2200-509
M06	XB7-2100-609	M56	XB7-2200-505
M07	XB7-2100-809	M57	XB7-2200-809
M08	XB7-2100-505	M58	XB7-2201-009
M11	XB7-2101-009		

III. WASHERS AND SHIM WASHERS

N, S & T. SHIM WASHERS

d (mm)	D (mm)		
	Class 1	Class 2	Class 3
1.5	-	2.6	3.2
1.8	2.7	3.1	3.7
2.1	3.2	3.6	4.2
2.3	3.6	4	4.6
2.6	4	4.4	5
3.1	4.6	5	5.6
3.6	5.4	5.8	6.4
4.1	5.7	6.6	8
4.6	6.4	7.4	9
5.2	7.2	8.2	10
5.7	7.8	9	11
6.2	8.5	9.8	12
6.7	9.2	10.5	13
7.2	10	11.4	14
7.7	10.6	12.2	15
8.2	11.4	13	16
8.7	12	13.8	17
9.2	12.8	14.6	18
9.7	13.5	15.4	19

Table 2

Thickness code	t (mm)
0	0.05
1	0.1
2	0.2
3	0.3
4	0.4
5	0.5
6	0.6
7	0.7
8	0.8
9	1

Table 3

LIST OF STANDARD FASTENERS

N, S & T. SHIM WASHERS (continued)

<u>Call out No.</u>	<u>Part Number</u>	<u>Call out No.</u>	<u>Part Number</u>	<u>Call out No.</u>	<u>Part Number</u>
N11	XD1-1102-112	S10	XD1-1105-221	T14	XD1-1107-224
N15	XD1-1102-121	S16	XD1-1105-230	T15	XD1-1107-225
N38	XD1-1103-119	S17	XD1-1105-231	T18	XD1-1107-228
		S18	XD1-1105-232	T22	XD1-1107-232
				T23	XD1-1107-233
N40	XD1-1103-121	S20	XD1-1105-234	T25	XD1-1107-235
N41	XD1-1103-122	S21	XD1-1105-235	T52	XD1-1108-212
N42	XD1-1103-123	S22	XD1-1105-236	T53	XD1-1108-213
N43	XD1-1103-124	S23	XD1-1105-237		
N44	XD1-1103-125			T55	XD1-1108-215
N48	XD1-1103-131	S45	XD1-1105-738	T56	XD1-1108-216
		S49	XD1-1106-213	T59	XD1-1108-219
N50	XD1-1103-133			T61	XD1-1108-221
N52	XD1-1103-135	S52	XD1-1106-216	T62	XD1-1108-222
N57	XD1-1103-139	S55	XD1-1106-219	T63	XD1-1108-223
		S57	XD1-1106-221	T65	XD1-1108-225
N61	NOT USED	S58	XD1-1106-222	T68	XD1-1108-228
N62	XD1-1103-625	S59	XD1-1106-223	T69	XD1-1108-229
N65	XD1-1103-629			T72	XD1-1108-232
		S61	XD1-1106-225	T75	XD1-1108-235
N74	XD1-1103-639	S64	XD1-1106-228	T79	XD1-1108-239
N75	XD1-1104-111	S65	XD1-1106-229		
N76	XD1-1104-112	S67	XD1-1106-231	T88	XD1-1109-235
N77	XD1-1104-113	S68	XD1-1106-232	T90	XD1-1109-239
N79	XD1-1104-115	S69	XD1-1106-233		
N82	XD1-1104-123	S71	XD1-1105-221		
N84	XD1-1104-125	S75	XD1-1105-221		
N88	XD1-1104-129				
		S88	XD1-1106-728		
N91	XD1-1104-133				
N92	XD1-1104-135	S92	XD1-1106-732		
N93	XD1-1104-136	S95	XD1-1106-735		
N94	XD1-1104-139	S99	XD1-1106-739		
N95	XD1-1104-615				
N96	XD1-1104-632				

LIST OF STANDARD FASTENERS

U. PLAIN WASHERS, SPRING WASHERS & TOOTHED LOCK WASHERS

Plain washers

<u>Call out No.</u>	<u>Part Number</u>	<u>Call out No.</u>	<u>Part Number</u>
U01	XD1-2100-207	U06	XD1-2100-607
U03	XD1-2100-307	U07	XD1-2100-807
U04	XD1-2100-407	U08	XD1-2101-007
U05	XD1-2100-507		

Spring washers

<u>Call out No.</u>	<u>Part Number</u>	<u>Call out No.</u>	<u>Part Number</u>
U51	XD1-3100-207	U56	XD1-3100-607
U53	XD1-3100-307	U57	XD1-3100-807
U54	XD1-3100-407	U61	XD1-3101-007
U55	XD1-3100-507		

Toothed lock washers

XD1-410 ... Inner toothed

XD1-420 ... Outer toothed

<u>Call out No.</u>	<u>Part Number</u>	<u>Call out No.</u>	<u>Part Number</u>
U81	XD1-4100-202	U91	XD1-4200-302
U83	XD1-4100-302	U92	XD1-4200-402
U84	XD1-4100-402	U93	XD1-4200-502
U85	XD1-4100-502	U94	XD1-4200-602
U86	XD1-4100-602	U95	XD1-4200-802
U87	XD1-4100-802		

IV. RETAINING RINGS

V. E RINGS

XD2-110 ... Class 1

XD2-120 ... Class 2

<u>Call out No.</u>	<u>Part Number</u>	<u>Call out No.</u>	<u>Part Number</u>	<u>Call out No.</u>	<u>Part Number</u>
V04	XD2-1100-202	V14	XD2-1100-302	V71	XD2-1200-322
V06	XD2-1100-302	V15	XD2-1100-402		
V07	XD2-1100-402	V16	XD2-1100-502		
V08	XD2-1100-502	V17	XD2-1100-602		
V09	XD2-1100-602	V56	XD2-1200-302		
V10	XD2-1100-302	V57	XD2-1200-402		
V11	XD2-1100-402	V58	XD2-1200-502		
V12	XD2-1100-502	V61	XD2-1200-802		
V13	XD2-1100-602	V70	XD2-1200-907		

LIST OF STANDARD FASTENERS

W. GRIP RINGS

<u>Call out No.</u>	<u>Part Number</u>
W01	XD2-2100-202
W03	XD2-2100-302
W05	XD2-2100-402
W07	XD2-2100-502
W08	XD2-2100-602
W10	XD2-2100-802
W12	XD2-2100-002

X. C RINGS

XD2-310 ... External type

XD2-320 ... Internal type

<u>Call out No.</u>	<u>Part Number</u>	<u>Call out No.</u>	<u>Part Number</u>	<u>Call out No.</u>	<u>Part Number</u>
X01	XD2-3100-102	X39	XD2-3200-162	X60	XD2-3200-378
X03	XD2-3100-122	X47	XD2-3200-222	X63	XD2-3200-422
X06	XD2-3100-148	X48	XD2-3200-228	X64	XD2-3200-428
X07	XD2-3100-152	X50	XD2-3200-258	X74	XD2-3200-558
X10	XD2-3101-168	X52	XD2-3200-288	X75	XD2-3200-602
X11	XD2-3100-172	X53	XD2-3200-302	X79	XD2-3200-682
X13	XD2-3100-182	X56	XD2-3200-328	X80	XD2-3200-688
X15	XD2-3100-202				
X16	XD2-3100-208				
X18	XD2-3100-228				
X20	XD2-3100-258				
X24	XD2-3100-308				

LIST OF STANDARD FASTENERS

V. PINS

Y. SPRING AND DOWEL PINS

Spring Pins

<u>Call out No.</u>	<u>Part Number</u>	<u>Call out No.</u>	<u>Part Number</u>
Y04	XD3-1120-102	Y33	XD3-1250-162
Y14	XD3-1160-122	Y41	XD3-1300-062
Y15	XD3-1160-142	Y42	XD3-1300-082
Y21	XD3-1200-052	Y43	XD3-1300-102
Y22	XD3-1200-062	Y44	XD3-1300-122
Y23	XD3-1200-082	Y45	XD3-1300-142
Y24	XD3-1200-102	Y46	XD3-1300-162
Y25	XD3-1200-122	Y47	XD3-1300-202
Y26	XD3-1200-142	Y49	XD3-1300-322
Y27	XD3-1200-162	Y51	XD3-1400-182
Y29	XD3-1200-202		

Dowel pins

<u>Call out No.</u>	<u>Part Number</u>	<u>Call out No.</u>	<u>Part Number</u>	<u>Call out No.</u>	<u>Part Number</u>
Y70	XD3-2160-082	Y75	XD3-2200-162	Y83	XD3-2300-182
Y71	XD3-2200-082	Y76	XD3-2200-182	Y84	XD3-2300-202
Y72	XD3-2200-102	Y80	XD3-2200-252	Y85	XD3-2300-222
Y73	XD3-2200-122	Y81	XD3-2300-142	Y86	XD3-2300-122
Y74	XD3-2200-142	Y82	XD3-2300-162		

VI. SPACERS

Z. SPACERS

<u>Call out No.</u>	<u>Part Number</u>	<u>Call out No.</u>	<u>Part Number</u>	<u>Call out No.</u>	<u>Part Number</u>
Z21	XZ1-1300-305	Z42	XZ1-1400-305	Z51	XZ1-1401-205
Z22	XZ1-1300-405	Z43	XZ1-1400-405	Z52	XZ1-1401-605
Z25	XZ1-1300-705	Z44	XZ1-1400-505	Z53	XZ1-1401-805
Z26	XZ1-1300-805	Z45	XZ1-1400-605	Z54	XZ1-1402-505
Z29	XZ1-1301-205	Z46	XZ1-1400-705	Z63	XZ1-1501-205
Z30	XZ1-1301-605	Z47	XZ1-1400-805	Z64	XZ1-1501-605
Z31	XZ1-1301-805	Z48	XZ1-1400-905	Z81	XZ1-1800-455
Z41	XZ1-1400-205	Z49	XZ1-1401-005		

PART NUMBER/DESCRIPTION INDEX 

THIS PAGE INTENTIONALLY LEFT BLANK

INDEX BY PART NUMBER

DECLaser 1100/1152

PART NO.	DESCRIPTION	FIG NO.	ITEM NO.
17-00083-09	Cord, Power (USA)	1	Not Shown
17-00198-14	Cord, Power (AUSTRALIA/NEW ZEALAND)	1	Not Shown
17-00199-21	Cord, Power (GERMANY/AUSTRIA)	1	Not Shown
17-00199-21	Cord, Power(BELG,FIN,FRA,HOL,NOR,PORT,SPN,SWD)	1	Not Shown
17-00209-15	Cord, Power (UK/IRELAND)	1	Not Shown
17-00210-13	Cord, Power (SWITZERLAND)	1	Not Shown
17-00310-08	Cord, Power (DENMARK)	1	Not Shown
17-00364-18	Cord, Power (ITALY)	1	Not Shown
17-00457-16	Cord, Power (ISRAEL)	1	Not Shown
17-00811-02	Cable Assembly, 6 Cond. EIA-423 MMJ	1	Not Shown
17-00811-02	Cable Assembly, 6 Cond. EIA-423 MMJ	1	Not Shown
17-00811-02	Cable Assembly, 6 Cond. EIA-423 MMJ	1	Not Shown
17-00811-02	Cable Assembly, 6 Cond. EIA-423 MMJ	1	Not Shown
17-00811-02	Cable Assembly, 6 Cond. EIA-423 MMJ	1	Not Shown
17-00811-02	Cable Assembly, 6 Cond. EIA-423 MMJ	1	Not Shown
17-00811-02	Cable Assembly, 6 Cond. EIA-423 MMJ	1	Not Shown
17-01364-01	Cable Assembly, Shielded EIA-423 MMJ	1	Not Shown
21-23613-04	EEPROM, Serial (Not Shown)	15	6
29-28994-01	Roller, Transfer	3	30
29-28995-01	Shaft, Feed Roller	16	1
29-28996-01	Shaft, Pick-Up Roller	16	2
29-28997-01	Module Assembly, DC Controller	1	15
29-28997-01	Module Assembly, DC Controller	7	21
29-28998-01	Module Assembly, Cassette Feeder	1	25
29-28998-01	Module Assembly, Cassette Feeder	16	2
29-28999-01	Module Assembly, H.V. Power Supply	1	23
29-28999-01	Module Assembly, H.V. Power Supply	7	22
29-29000-01	Laser Assembly	6	13
29-29001-01	Motor Assembly, Scanner	6	14
29-29002-01	Lens Assembly	6	15
29-29003-01	DRIVE ASSEMBLY	1	9
29-29003-01	DRIVE ASSEMBLY	10	N/A
29-29003-01	DRIVE ASSEMBLY	6	26
29-29004-01	FEEDER ASSEMBLY	1	12
29-29004-01	FEEDER ASSEMBLY	13	N/A
29-29004-01	FEEDER ASSEMBLY	6	25
29-29005-01	ROLLER ASSEMBLY, TRAY PICK-UP	1	11
29-29005-01	ROLLER ASSEMBLY, TRAY PICK-UP	12	N/A
29-29005-01	ROLLER ASSEMBLY, TRAY PICK-UP	3	33
29-29006-01	Inlet Assembly, Power (100/115V)	1	7
29-29006-01	Power Inlet Assembly (100/115V)	7	25
29-29007-01	Pad, Separation	6	9
29-29008-01	Module Assembly, Density Adjusting	1	20
29-29008-01	Module Assembly, Density Adjusting	5	12
29-29009-01	Fan, 2.64W DC 12V	5	11
29-29010-01	Motor, Main Stepping DC 4W	6	7
29-29013-01	Interface Assembly (DECLaser 1100)	7	23
29-29013-01	Module Assembly, Interface	1	19
29-29014-01	FIXING ASSEMBLY (100/115V)	1	14
29-29014-01	FIXING ASSEMBLY (100/115V)	3	34
29-29014-01	FIXING ASSEMBLY (100/115V)	8	N/A

INDEX BY PART NUMBER

DEClaser 1100/1152

PART NO.	DESCRIPTION	FIG NO.	ITEM NO.
29-29015-01	COVER ASSEMBLY, FRONT (100/115V)	1	2
29-29015-01	COVER ASSEMBLY, FRONT (LN07) (115V)	3	N/A
29-29016-01	COVER ASSEMBLY, FRONT (220/240V)	1	2
29-29016-01	COVER ASSEMBLY, FRONT (LN07) (240V)	3	N/A
29-29017-01	Panel, Control (DEClaser 1100)	4	6
29-29018-01	Module Assembly, Video Controller	1	16
29-29018-01	Module Assy, Video Controller (DEClaser 1100)	15	5
29-29019-01	Tray Assembly, Multi-Purpose	2	5
29-29020-01	FIXING ASSEMBLY (220/240V)	1	14
29-29020-01	FIXING ASSEMBLY (220/240V)	3	34
29-29020-01	FIXING ASSEMBLY (220/240V)	8	N/A
29-29021-01	Inlet Assembly, Power (220/240V)	1	7
29-29021-01	Power Inlet Assembly (220/240V)	7	25
29-30382-01	Module Assembly, Video Controller (DEClaser 1152)	15	5
29-30383-01	Interface Assembly (DEClaser 1152)	7	24
29-30567-01	COVER ASSEMBLY, FRONT (100/115V)	1	2
29-30567-01	COVER ASSEMBLY, FRONT (LN07C) (115V)	3	N/A
29-30568-01	COVER ASSEMBLY, FRONT (220/240V)	1	2
29-30568-01	COVER ASSEMBLY, FRONT (LN07C) (240V)	3	N/A
29-30569-01	Panel, Control (DEClaser 1152)	4	6
EK-D1100-DK	Documentation, User (English)	1	N/S
FA9-1643-000	Screw, Machine Truss Head M3 x 10	6	22
FB1-2267-000	Screw, Machine Truss Head M3 x 4	17	12
FB1-2267-000	Screw, Machine Truss Head M3 x 4	18	13
LN07-A2	DEClaser 1100 PRINTER ASSEMBLY (30-34808-01) (110/115V)	1	N/A
LN07-A3	DEClaser 1100 PRINTER ASSEMBLY (30-34808-02) (220/240V)	1	N/A
LN07C-A2	DEClaser 1152 PRINTER ASSEMBLY (30-39642-01) (100/115V)	1	N/A
LN07C-A3	DEClaser 1152 PRINTER ASSEMBLY (30-39642-02) (220/240V)	1	N/A
LN07R-UA	KIT, PostScript UPGRADE (VMS SWL)	1	Not Shown
LN07U-PS	Cartridge, PostScript ROM (30-34892-01)	1	Not Shown
LN07U-UA	KIT, PostScript UPGRADE (2 MB Mem)	1	Not Shown
LN07X-AA	Kit, Toner/Supplies Cartridge	1	Not Shown
LN07X-MA	Module Assembly, RAM-V	1	27
LN07X-MC	Module Assembly, RAM-C	1	28
LN07X-PS	Cartridge, PostScript ROM (30-34892-01)	1	Not Shown
LN07X-TA	Tray, A4 Size Paper Input	1	Not Shown
LN07X-TB	Cassette, Legal Size Paper	1	Not Shown
LN07X-TC	Cassette, Letter Size Paper	1	Not shown
LN07X-TD	Cassette, Envelope Size	1	Not Shown
LN07X-TE	Cassette, Executive Size Paper	1	Not Shown
LN07X-TF	Cassette, Optional Lower w/Letter Tray	1	Not Shown
LN07X-TG	Tray, Large Capacity Letter Size Paper	1	Not Shown
LN07X-UC	Card, 1 MB RAM (20-34856-01)	1	Not Shown
LN07X-UE	Module, 1 MB Daughter Board Add-On (12-34857-01)	1	Not Shown
LN07X-UF	Module, Memory Option 2 MB RAM (DEClaser 1152 Only)	1	Not Shown

INDEX BY PART NUMBER

DECLaser 1100/1152

PART NO.	DESCRIPTION	FIG NO.	ITEM NO.
RA1-7440-030	Arm, No. 1	6	16A
RA1-7441-000	Arm, No. 2	6	16B
RA1-7442-000	Arm, No. 3	6	16C
RA1-7446-000	Block, Fiber Holder	6	1
RA1-7453-000	Foot	7	5
RA1-7456-000	Plate, Grounding	5	3
RA1-7459-000	Plate Nut, Left	5	6
RA1-7463-000	Plate, Grounding	10	1
RA1-7469-000	Arm, Roller Mounting	13	1
RA1-7470-000	Shaft, Drive	13	2
RA1-7473-000	Plate	13	3
RA1-7474-000	Lever, Sensor	13	4
RA1-7475-000	Cover, H.V. Power Supply	7	8
RA1-7476-000	Mount, Plate Contact	9	1
RA1-7477-000	Plate, Drum Contact	9	2
RA1-7478-000	Plate, Contact (T)	9	3
RA1-7479-000	Plate, Contact (P)	9	4
RA1-7480-000	Plate, Contact (D)	9	5
RA1-7482-000	Lever, Shutter	11	2
RA1-7483-000	Plate, Retainer	11	3
RA1-7484-000	Rack	11	4
RA1-7485-000	Block, Support Rod	11	5
RA1-7499-000	Pivot	6	12
RA1-7502-000	Cover, Cable	6	11A
RA1-7506-000	Cover, Cord	6	2
RA1-7507-000	Plate, Tray Stopper	6	3
RA1-7510-000	Plate, Blanking	8	46
RA1-7528-000	Plate, Left Mounting	4	3
RA1-7532-000	Plate, Right Mounting	4	7
RA1-7533-000	Mount, PCB (Module)	7	11
RA1-7535-000	Plate, Stack-End	7	1
RA1-7536-000	Guide, I/O	7	2
RA1-7538-000	Mount, Module	15	1
RA1-7540-000	Cover, Shield	15	2
RA1-7542-000	Guide, Font	15	3
RA1-7544-000	Rail	15	4
RA1-7549-000	Guide, Slide	4	11
RA1-7550-000	Plate, Paper Support	4	4
RA1-7551-000	Mounting, Rear Cover	4	5
RA1-7552-000	Mount, Positioning	7	12
RA1-7560-000	Ring	2	3B
RA1-7562-000	Lever, Paper Sensor	3	14
RA1-7563-000	Mount, Rod	3	21
RA1-7565-000	Plate A, Grounding	3	15
RA1-7566-000	Plate B, Grounding	3	16
RA1-7569-000	Spring, Leaf	14	1
RA1-7570-000	Mount, Sensor	3	27B
RA1-7571-000	Cam	12	5
RA1-7573-000	Roller, Pick-Up	12	1
RA1-7574-000	Bushing	12	2
RA1-7575-000	Roller	12	3
RA1-7578-000	Ring, Idler	12	4
RA1-7579-000	Guide, Cord	3	27C

INDEX BY PART NUMER

DEClaser 1100/1152

PART NO.	DESCRIPTION	FIG NO.	ITEM NO.
RA1-7583-000	Roller, Lower Fixing	8	3
RA1-7585-020	Spring, Leaf	8	5
RA1-7586-000	Bushing	8	6
RA1-7587-000	Bushing	8	7
RA1-7588-000	Lever, Delivery Sensor	8	8
RA1-7589-000	Plate, Left Cable	8	9
RA1-7591-000	Plate, Right Cable	8	10
RA1-7592-000	Plate, Right Hook	8	11
RA1-7593-000	Plate, Left Hook	8	12
RA1-7594-000	Guide, Entrance	8	13
RA1-7595-000	Holder, Right Connector	8	14
RA1-7596-000	Holder, Left Connector	8	15
RA1-7598-000	Plate, Left Lifting	8	17
RA1-7599-000	Plate, Right Lifting	8	18
RA1-7600-000	Eliminator, Static Charge	8	19
RA1-7602-000	Spring, Thermistor Leaf	8	21
RA1-7603-000	Rod, Latch	8	22
RA1-7604-030	Spring, Grounding Leaf	8	23
RA1-7607-000	Spring, Torsion	8	25
RA1-7608-000	Plate, Cable No. 1	8	26
RA1-7609-000	Plate, Cable No. 2	8	27
RA1-7610-000	Cover, Wire	8	28
RA1-7611-000	Support, Roller	3	29A
RA1-7613-000	Cover, FD	14	2
RA1-7616-000	Mount, Left FD Cover	14	8
RA1-7617-000	Plate, Continuity No. 1	8	29
RA1-7618-000	Plate, Continuity No. 2	8	30
RA1-7619-000	Plate, Continuity No. 3	8	31
RA1-7620-000	Plate, Continuity No. 4	8	32
RA1-7621-000	Retainer, TR Left	3	12A
RA1-7622-020	Retainer, TR Right	3	13A
RA1-7623-000	Bushing	3	12B
RA1-7625-000	Guide, Sheet	3	7A
RA1-7626-000	Deflector	3	1
RA1-7628-000	Cap, Spring	3	3
RA1-7629-000	Arm, Paper Pick-up	3	4
RA1-7630-080	Tray, Face-Up	2	4
RA1-7632-000	Cover, Front Cord	3	19
RA1-7636-000	Screw, Stepped M3	8	40
RA1-7637-000	Holder, Cord	3	18
RA1-7639-000	Plate, Grounding	6	19
RA1-7656-000	Ring (A), Ratchet	16	3
RA1-7657-000	Spring (A), Clutch	16	4
RA1-7658-000	Ring (B), Ratchet	16	5
RA1-7659-000	Spring (B), Clutch	16	6
RA1-7660-000	Ring	16	7
RA1-7661-000	Arm, Sensing	16	8
RA1-7662-000	Mount, Sensor	16	9
RA1-7663-020	Mount, (PCB) Module	16	10
RA1-7664-000	Spring, Leaf	16	11
RA1-7665-000	Mount, Solenoid	16	12
RA1-7666-000	Guide, Cassette	16	13
RA1-7674-000	Roller, Pick-Up	16	15
RA1-7689-000	Sheet, Friction (A4)	17	13A

INDEX BY PART NUMBER

DECLaser 1100/1152

PART NO.	DESCRIPTION	FIG NO.	ITEM NO.
RA1-7691-000	Sheet, Friction (LGL)	17	13A
RA1-7691-000	Sheet, Friction (LTR)	18	14A
RA1-7692-000	Sheet, Friction (EXE)	18	14A
RA1-7693-000	Plate, Length Adjustment	18	1
RA1-7696-000	Spring, Leaf	17	1
RA1-7696-000	Spring, Leaf	18	2
RA1-7698-000	Plate, Claw	17	2
RA1-7698-000	Plate, Claw	18	3
RA1-7699-000	Roller	17	3
RA1-7699-000	Roller	18	4
RA1-7700-000	Rod, Roller	17	4
RA1-7700-000	Rod, Roller	18	5
RA1-7701-000	Spring, Leaf	17	5
RA1-7701-000	Spring, Leaf	18	6
RA1-7702-000	Plate	17	6
RA1-7702-000	Plate	18	7
RA1-7703-000	Rod	17	7
RA1-7703-000	Rod	18	8
RA1-7703-000	Rod	19	8
RA1-7704-000	Pivot	17	8
RA1-7704-000	Pivot	18	9
RA1-7704-000	Pivot	19	9
RA1-7706-000	Sheet	17	13B
RA1-7706-000	Sheet	18	14B
RA1-7708-040	Roller, Delivery	14	4
RA1-7709-000	Support, Right Roller	14	5
RA1-7710-000	Support, Left Roller	14	6
RA1-7714-000	Roller, Delivery	3	28B
RA1-7715-000	Shaft	3	29B
RA1-7716-000	Plate, Grounding	3	28C
RA1-7717-000	Arm, Sensing	3	23
RA1-7718-000	Spring, Torsion	3	24
RA1-7721-000	Cover, Front Upper	3	28A
RA1-7730-000	Plate, Insulating	8	50
RA1-7803-000	Screw, Stepped M3	8	51
RA1-7811-000	Plate, Grounding (2)	5	7
RA1-7812-000	Arm, Auxiliary	13	5
RA1-7816-000	Plate, Grounding	7	9
RA1-7818-000	Sheet	5	1A
RA1-7821-000	Guide, Roller	16	29
RA1-7822-000	Support, Roller	3	28F
RA1-7823-000	Support, Plate (EXE)	18	18
RA1-7824-000	Roller, Pick-Up	16	30
RA1-7825-000	Plate, Grounding	3	2A
RA1-7828-000	Spring, Leaf	8	39
RA1-8227-000	Pad	5	1B
RA1-8231-000	Lever	9	7
RA1-8232-000	Plate, Contact	9	8
RA1-8233-000	Bushing	3	2B
RA1-8234-000	Plate	3	2C
RA1-8241-000	Cover, Cassette	17	17
RA1-8241-000	Cover, Cassette	18	19
RA1-8241-000	Cover, Cassette	19	16

INDEX BY PART NUMBER

DEClaser 1100/1152

PART NO.	DESCRIPTION	FIG NO.	ITEM NO.
RA1-8245-000	Plate, Continuity	8	33
RA1-8246-000	Holder, Diode	8	34
RA1-8254-000	Contact	3	2F
RA1-8255-000	Plate, Hook Shaft	3	17
RA1-8260-000	Sheet, Insulation	8	49
RA1-8262-000	Slider, Print Density	5	4
RA1-8264-000	Plate, Cable	8	53
RA1-8264-000	Plate, Cable	8	54
RA1-8265-030	Sheet	8	1A
RA1-8357-000	Strip, Friction	19	11A
RA1-8358-000	Plate, Right Hold-down Tab	19	1
RA1-8363-000	Plate, End Length Adjustment	19	2
RA1-8365-000	Pad	19	13A
RA1-8366-000	Roller	19	3
RA1-8367-000	Rod, Roller	19	4
RA1-8368-000	Spring, Leaf	19	5
RA2-0081-000	Slider	4	10
RA2-0757-000	Bushing	3	13B
RA2-0762-000	Plate, Sensor Mounting	5	2
RA2-0766-000	Rod, Latch	8	22
RA2-0767-000	Plate, Left Hook	8	12
RA2-0876-000	Guide, Paper	4	2
RA2-0877-000	Panel, Left	2	2
RA2-0878-000	Panel, Right	2	1
RA2-0886-000	Cover, Stop	16	14
RA2-0893-000	Label, Size (A4)	17	14A
RA2-0895-000	Label, Size (LGL)	17	14A
RA2-0897-000	Cover (for LGL only)	17	9
RA9-0603-000	Screw, M3	7	6
RA9-0621-000	Screw, Stepped M3	3	11
RA9-0621-000	Screw, Stepped M3	7	3
RA9-0689-000	Tape	3	32
RF1-2382-000	Cable, H.V.	9	6
RF1-2385-000	Cable, Sensor	6	11B
RF1-2393-000	Plate, Drive	10	7
RF1-2394-000	Roller, Paper Feed	13	11
RF1-2395-000	Arm, Drive	13	12
RF1-2400-050	PLATE, PAPER GUIDE	3	7
RF1-2405-030	Cable Assembly, Thermistor	8	44
RF1-2406-000	CABLE ASSEMBLY,	16	25
RF1-2422-000	PLATE, PAPER LIFTING(A4)	17	13
RF1-2424-000	PLATE, PAPER LIFTING (LGL)	17	13
RF1-2424-000	PLATE, PAPER LIFTING (LTR)	18	14
RF1-2425-000	PLATE, PAPER LIFTING (EXE)	18	14
RF1-2426-000	Plate, Size	17	15
RF1-2426-000	Plate, Size	18	14B
RF1-2427-000	Cable Assembly, AC Connector	8	45
RF1-2436-000	BODY, CASSETTE (LTR)	18	16
RF1-2438-000	BODY, CASSETTE (EXE)	18	16
RF1-2483-020	Thermoswitch (Cont)	8	42
RF1-2484-020	Thermoswitch (NOC)	8	43
RF1-2491-000	Roller, Delivery	3	8
RF1-2494-000	Diode, SHV-02	8	35

INDEX BY PART NUMBER

DECLaser 1100/1152

PART NO.	DESCRIPTION	FIG NO.	ITEM NO.
RF1-2495-000	Guide, Paper Delivery	8	20
RF1-2496-000	Guide	3	2E
RF1-2501-000	COVER, INNER	5	1
RF1-2502-000	Rod	11	1
RF1-2505-000	Roller, Upper Fixing	8	2
RF1-2511-030	Cover	6	16D
RF1-2597-000	PLATE, PAPER LIFTING	19	11
RF1-2598-000	Plate, End Width Adjustment	19	12
RF1-2599-000	PAD ASSEMBLY	19	13
RF1-2600-000	Plate	19	14
RF1-2602-000	CASSETTE BODY	19	15
RF1-3093-000	Frame	8	1
RF1-3095-000	Spring, Leaf	8	24
RF1-3170-000	Cover, Upper	4	1
RF1-3171-000	PANEL, REAR	2	3
RF1-3172-000	Cover, Right Feeder	16	23
RF1-3173-000	CASSETTE BODY (LGL)	17	14
RF1-3174-000	CASSETTE BODY (A4)	17	14
RF1-3178-000	Cover, Left Feeder	16	24
RG1-1602-000	Module Assembly, Fixing AC	3	26
RG1-1608-000	CABLE ASSEMBLY	3	27
RG1-1609-000	Cable Assembly, Rear	7	4
RG1-1612-000	CABLE ASSEMBLY, PICK-UP SENSOR	6	11
RG1-1773-040	SHUTTER ASSEMBLY	6	16
RG1-1777-000	Drive Assembly, Drum	6	10
RG1-1780-000	CONTACT ASSEMBLY, H.V.	1	8
RG1-1780-000	CONTACT ASSEMBLY, H.V.	6	23
RG1-1780-000	CONTACT ASSEMBLY, H.V.	9	N/A
RG1-1781-000	ROD ASSEMBLY	1	10
RG1-1781-000	ROD ASSEMBLY	11	N/A
RG1-1781-000	ROD ASSEMBLY	6	24
RG1-1791-000	DELIVERY ASSEMBLY, FACE-DOWN	1	13
RG1-1791-070	DELIVERY ASSEMBLY, FACE DOWN	3	35
RG1-1791-070	DELIVERY ASSEMBLY, FACE-DOWN	14	N/A
RG1-1793-000	MOUNT ASSEMBLY, LEFT TR ROLLER	3	12
RG1-1794-030	MOUNT ASSEMBLY, RIGHT TR ROLLER	3	13
RG1-1823-000	Interface Assembly	1	18
RG1-1832-000	COVER ASSEMBLY, FACE-UP	3	28
RG1-1833-000	DRIVE ASSEMBLY, FACE-UP DELIVERY	3	29
RG1-1835-000	Module Assembly, AC Controller (100/115V)	1	21
RG1-1836-000	Module Assembly, AC Controller (220/240V)	1	21
RG1-1915-000	COVER ASSEMBLY, INTERNAL	1	4
RG1-1915-000	COVER ASSEMBLY, INTERNAL	5	N/A
RG1-2633-000	CONTROLLER ASSEMBLY, VIDEO	1	22
RG1-2633-000	CONTROLLER ASSEMBLY, VIDEO	15	N/A
RG9-0681-000	GUIDE ASSEMBLY, TRANSFER	3	2
RH2-5104-000	Cable Assembly, Optical Fiber	6	8
RH2-5105-000	Pin Assembly, 3P	3	27E
RH2-5115-000	Cord, Power (100/115V)	7	26
RH2-5116-000	Cord, Power (220/240V)	7	26
RH6-3091-000	Resistor, 68M OHM, 1/2W	3	2D
RH6-3097-000	Diode, AM01A	8	55
RH7-4032-000	Heater, Halogen (100/115V)	8	41

INDEX BY PART NUMBER

DEClaser 1100/1152

PART NO.	DESCRIPTION	FIG NO.	ITEM NO.
RH7-4033-000	Heater, Halogen (220/240V)	8	41
RH7-5025-000	Solenoid, DC 24V	16	25A
RH7-5026-000	Solenoid, DC 24V	16	25B
RH7-6016-000	Switch, Rocker	7	10
RS1-0276-000	Gear, 86T	10	3
RS1-0277-000	Gear, 107T/17T	10	4
RS1-0281-000	Gear, 25T	13	6
RS1-0283-000	Gear, 15T	13	7
RS1-0284-000	Gear, 30T	6	4
RS1-0287-000	Gear, 27T/21T	8	36
RS1-0288-000	Gear, 14T	3	29C
RS1-0290-000	Gear, 30T	3	5
RS1-0291-000	Gear, 20T	3	22
RS1-0292-000	Gear, 27	3	31
RS1-0295-000	Gear, 33T/19T	16	16
RS1-0296-000	Gear, 17T	16	17
RS1-0297-000	Gear, 37T	16	18
RS1-0298-000	Gear, 39T	16	19
RS1-0299-000	Gear, 34T	16	20
RS1-0303-000	Gear, 13T	14	7
RS1-0304-000	Gear, 15T	3	29D
RS1-0305-000	Gear, 14T	3	28E
RS1-0306-000	Gear, 15T	3	28D
RS1-1048-000	Bushing	6	5
RS1-1053-000	Bushing	16	21
RS1-1054-000	Bushing	16	22
RS1-2234-000	Spring, Tension	6	16E
RS1-2235-000	Spring, Tension	10	5
RS1-2236-000	Spring, Tension	13	8
RS1-2237-000	Spring, Compression	13	9
RS1-2238-000	Spring, Tension	11	6
RS1-2239-000	Spring, Tension	11	7
RS1-2241-000	Spring, Compression	8	37
RS1-2242-000	Spring, Compression	3	12C
RS1-2242-000	Spring, Compression	3	13C
RS1-2244-000	Spring, Compression	3	9
RS1-2247-000	Spring, Tension (EXE)	18	12
RS1-2248-000	Spring, Tension	14	3
RS1-2251-000	Spring, Tension	17	10
RS1-2251-000	Spring, Tension (LTR)	18	10
RS1-2252-000	Spring, Tension	17	11
RS1-2252-000	Spring, Tension (LTR)	18	11
RS1-2253-000	Spring, Tension	3	25
RS1-2254-000	Spring, Compression	16	31
RS1-2255-000	Spring, Compression	8	52
RS1-2265-000	Spring, Tension	19	6
RS1-2266-000	Spring, Tension	19	7
RS1-6047-020	Collar, Retaining	16	32
RS1-8790-000	Label	5	1C
RS1-8797-000	Label, Size (LTR)	18	16A
RS1-8799-000	Label, Size (EXE)	18	16A
RS1-8805-000	Label	18	16B
RS1-8805-000	Label	19	15B

INDEX BY PART NUMBER

DECLaser 1100/1152

PART NO.	DESCRIPTION	FIG NO.	ITEM NO.
RS1-8805-000	Label, Size	19	15A
RS1-8836-000	Label	18	16B
RS1-8837-000	Label	19	15C
RS1-8839-000	Label, Caution	19	15D
RS1-8842-000	Label	17	14B
RS1-8843-000	Label	17	14C
SG5-4115-000	Module Assembly, ROM	1	17
SH8-4167-000	Buzzer	4	9
VT2-0016-004	Support, PCB (Module)	7	15
VT2-0021-001	Clamp	10	2
WA1-1124-000	Diode, SHV-02	3	27D
WG8-0291-000	Photo-Interrupter	13	10
WG8-0291-000	Photo-Interrupter	16	26
WG8-0291-000	Photo-Interrupter TLP1230	5	10
WG8-0323-000	Photo-Interrupter	3	27A
WT2-0317-000	Clip, Cable	5	8
WT2-0317-000	Clip, Cable	7	14
WT2-0389-000	Tie, Cable	6	11C
WT2-0505-000	Tie, Cable	5	9
WT2-5011-000	Clip, Cable	7	13
WT2-5059-000	Clip	10	6
XA9-0134-000	Nut, Push	8	56
XA9-0233-000	Screw, M3 x 6	8	47
XA9-0259-000	Screw, Machine Truss Head M3 x 8	6	20
XA9-0259-000	Screw, Machine Truss Head M3 x 8	7	18
XA9-0267-000	Screw, M3 x 6 (TP)	7	17
XA9-0267-000	Screw, M3 x 6 (TP)	8	38
XA9-0302-000	Screw, M3 x 8 (TP)	7	20
XA9-0382-000	Screw, TP M3 x 12	3	6
XA9-0459-000	Screw, Machine Truss Head M3 x 16	6	17
XA9-0462-000	Screw, Machine Truss Head M3 x 10	6	18
XA9-0475-000	Screw, M3 x 10	4	13
XA9-0488-000	Screw, w/Washer M3 x 16	6	6
XA9-0494-000	Screw, M3	16	27
XA9-0495-000	Screw, TP M3 x 10	2	3A
XA9-0497-000	Screw, Machine Truss Head M4 x 10	6	21
XA9-0498-000	Screw, w/Washer M3 x 8	7	19
XA9-0499-000	Screw, w/Washer M4	7	24
XA9-0500-000	Screw, w/Washer M3 x 6	7	16
XA9-0516-000	Screw	4	14
XA9-0535-000	Screw	4	12
XB2-7300-607	Screw, M3 x 6	8	48
XB2-7300-807	Screw, w/Washer M3 x 8	3	10
XB5-6300-509	Screw, M3 x 6 (TP)	10	8
XD9-0079-000	Washer, Wave	8	16
XD9-0101-000	Ring, E	17	16
XD9-0101-000	Ring, E	18	17
XD9-0101-000	Ring, E	19	10
XD9-0103-000	Pin, Dowel	13	13
XD9-0108-000	Pin, Dowel	12	6
XD9-0111-000	Pin, Dowel	15	9
XH9-0059-000	Foot, Rubber	7	7

INDEX BY PART NUMBER
DEClaser 1100/1152

PART NO.	DESCRIPTION	FIG NO.	ITEM NO.
----------	-------------	------------	-------------

THIS PAGE INTENTIONALLY LEFT BLANK

INDEX BY PART DESCRIPTION

DECClasser 1100/1152

DESCRIPTION	DEC PART NO.	FIG. NO.	ITEM NO.
Arm, Auxiliary	RA1-7812-000	13	5
Arm, Drive	RF1-2395-000	13	12
Arm, No. 1	RA1-7440-030	6	16A
Arm, No. 2	RA1-7441-000	6	16B
Arm, No. 3	RA1-7442-000	6	16C
Arm, Paper Pick-up	RA1-7629-000	3	4
Arm, Roller Mounting	RA1-7469-000	13	1
Arm, Sensing	RA1-7661-000	16	8
Arm, Sensing	RA1-7717-000	3	23
Block, Fiber Holder	RA1-7446-000	6	1
Block, Support Rod	RA1-7485-000	11	5
BODY, CASSETTE (EXE)	RF1-2438-000	18	16
BODY, CASSETTE (LTR)	RF1-2436-000	18	16
Bushing	RA1-7574-000	12	2
Bushing	RA1-7586-000	8	6
Bushing	RA1-7587-000	8	7
Bushing	RA1-7623-000	3	12B
Bushing	RA1-8233-000	3	2B
Bushing	RA2-0757-000	3	13B
Bushing	RS1-1048-000	6	5
Bushing	RS1-1053-000	16	21
Bushing	RS1-1054-000	16	22
Buzzer	SH8-4167-000	4	9
CABLE ASSEMBLY	RG1-1608-000	3	27
CABLE ASSEMBLY	RF1-2406-000	16	25
Cable Assembly, 6 Cond. EIA-423 MMJ	17-00811-02	1	Not Shown
Cable Assembly, 6 Cond. EIA-423 MMJ	17-00811-02	1	Not Shown
Cable Assembly, 6 Cond. EIA-423 MMJ	17-00811-02	1	Not Shown
Cable Assembly, 6 Cond. EIA-423 MMJ	17-00811-02	1	Not Shown
Cable Assembly, 6 Cond. EIA-423 MMJ	17-00811-02	1	Not Shown
Cable Assembly, 6 Cond. EIA-423 MMJ	17-00811-02	1	Not Shown
Cable Assembly, 6 Cond. EIA-423 MMJ	17-00811-02	1	Not Shown
Cable Assembly, AC Connector	RF1-2427-000	8	45
Cable Assembly, Optical Fiber	RH2-5104-000	6	8
CABLE ASSEMBLY, PICK-UP SENSOR	RG1-1612-000	6	11
Cable Assembly, Rear	RG1-1609-000	7	4
Cable Assembly, Shielded EIA-423 MMJ	17-01364-01	1	Not Shown
Cable Assembly, Thermistor	RF1-2405-030	8	44
Cable, H.V.	RF1-2382-000	9	6
Cable, Sensor	RF1-2385-000	6	11B
Cam	RA1-7571-000	12	5
Cap, Spring	RA1-7628-000	3	3
Card, 1MB RAM (20-34856-01)	LN07X-UC	1	Not Shown
Cartridge, PostScript ROM (30-34892-01)	LN07U-PS	1	Not Shown
Cartridge, PostScript ROM (30-34892-01)	LN07X-PS	1	Not Shown
CASSETTE ASSEMBLY (A4, LGL)	N/A	1	26
CASSETTE ASSEMBLY (A4, LGL)	N/A	17	N/A
CASSETTE ASSEMBLY (ENVELOPE)	N/A	1	26
CASSETTE ASSEMBLY (ENVELOPE)	N/A	19	N/A
CASSETTE ASSEMBLY (LTR, EXE)	N/A	1	26
CASSETTE ASSEMBLY (LTR, EXE)	N/A	18	N/A
CASSETTE BODY	RF1-2602-000	19	15
CASSETTE BODY (A4)	RF1-3174-000	17	14

INDEX BY PART DESCRIPTION

DEClaser 1100/1152

DESCRIPTION	DEC PART NO.	FIG. NO.	ITEM NO.
CASSETTE BODY (LGL)	RF1-3173-000	17	14
Cassette, Envelope Size	LN07X-TD	1	Not Shown
Cassette, Executive Size Paper	LN07X-TE	1	Not Shown
Cassette, Legal Size Paper	LN07X-TB	1	Not Shown
Cassette, Letter Size Paper	LN07X-TC	1	Not Shown
Cassette, Optional Lower w/Letter Tray	LN07X-TF	1	Not Shown
Clamp	VT2-0021-001	10	2
Clip	WT2-5059-000	10	6
Clip, Cable	WT2-0317-000	5	8
Clip, Cable	WT2-0317-000	7	14
Clip, Cable	WT2-5011-000	7	13
Collar, Retaining	RS1-6047-020	16	32
COMPONENTS ASSEMBLY, INTERNAL	N/A	1	5
COMPONENTS ASSEMBLY, INTERNAL	N/A	6	N/A
Contact	RA1-8254-000	3	2F
CONTACT ASSEMBLY, H.V.	RG1-1780-000	1	8
CONTACT ASSEMBLY, H.V.	RG1-1780-000	6	23
CONTACT ASSEMBLY, H.V.	RG1-1780-000	9	N/A
CONTROLLER ASSEMBLY, VIDEO	RG1-2633-000	1	22
CONTROLLER ASSEMBLY, VIDEO	RG1-2633-000	15	N/A
Cord, Power (100/115V)	RH2-5115-000	7	26
Cord, Power (220/240V)	RH2-5116-000	7	26
Cord, Power (AUSTRALIA/NEW ZEALAND)	17-00198-14	1	Not Shown
Cord, Power (DENMARK)	17-00310-08	1	Not Shown
Cord, Power (GERMANY/AUSTRIA)	17-00199-21	1	Not Shown
Cord, Power (ISRAEL)	17-00457-11	16	Not Shown
Cord, Power (ITALY)	17-00364-18	1	Not Shown
Cord, Power (SWITZERLAND)	17-00210-13	1	Not Shown
Cord, Power (UK/IRELAND)	17-00209-15	1	Not Shown
Cord, Power (USA)	17-00083-09	1	Not Shown
Cord, Power(BELG,FIN,FRA,HOL,NOR,PORT,SPN,SWD)	17-00199-21	1	Not Shown
Cover	RF1-2511-030	6	16D
COVER ASSEMBLY, UPPER	N/A	1	3
COVER ASSEMBLY, UPPER	N/A	4	N/A
COVER, INNER	RF1-2501-000	5	1
Cover (for LGL only)	RA2-0897-000	17	9
Cover, Cable	RA1-7502-000	6	11A
Cover, Cassette	RA1-8241-000	17	17
Cover, Cassette	RA1-8241-000	18	19
Cover, Cassette	RA1-8241-000	19	16
Cover, Cord	RA1-7506-000	6	2
COVER ASSEMBLY, FACE-UP	RG1-1832-000	3	28
Cover, FD	RA1-7613-000	14	2
COVER ASSEMBLY, FRONT (100/115V)	29-29015-01	1	2
COVER ASSEMBLY, FRONT (100/115V)	29-30567-01	1	2
COVER ASSEMBLY, FRONT (220/240V)	29-29016-01	1	2
COVER ASSEMBLY, FRONT (220/240V)	29-30568-01	1	2
COVER ASSEMBLY, FRONT (LN07) (115V)	29-29015-01	3	N/A
COVER ASSEMBLY, FRONT (LN07) (240V)	29-29016-01	3	N/A
COVER ASSEMBLY, FRONT (LN07C) (115V)	29-30567-01	3	N/A
COVER ASSEMBLY, FRONT (LN07C) (240V)	29-30568-01	3	N/A
Cover, Front Cord	RA1-7632-000	3	19

INDEX BY PART DESCRIPTION

DEC Laser 1100/1152

DESCRIPTION	DEC PART NO.	FIG. NO.	ITEM NO.
Cover, Front Upper	RA1-7721-000	3	28A
Cover, H.V. Power Supply	RA1-7475-000	7	8
COVER ASSEMBLY, INTERNAL	RG1-1915-000	1	4
COVER ASSEMBLY, INTERNAL	RG1-1915-000	5	N/A
Cover, Left Feeder	RF1-3178-000	16	24
Cover, Right Feeder	RF1-3172-000	16	23
Cover, Shield	RA1-7540-000	15	2
Cover, Stop	RA2-0886-000	16	14
Cover, Upper	RF1-3170-000	4	1
Cover, Wire	RA1-7610-000	8	28
DEC Laser 1100 PRINTER ASSY (30-34808-01) (110/115V)	LN07-A2	1	N/A
DEC Laser 1100 PRINTER ASSY (30-34808-02) (220/240V)	LN07-A3	1	N/A
DEC Laser 1152 PRINTER ASSY (30-39642-01) (100/115V)	LN07C-A2	1	N/A
DEC Laser 1152 PRINTER ASSY (30-39642-02) (220/240V)	LN07C-A3	1	N/A
DELIVERY ASSEMBLY, FACE DOWN	RG1-1791-070	3	35
DELIVERY ASSEMBLY, FACE-DOWN	RG1-1791-000	1	13
DELIVERY ASSEMBLY, FACE-DOWN	RG1-1791-070	14	N/A
DRIVE ASSEMBLY	29-29003-01	1	9
DRIVE ASSEMBLY	29-29003-01	10	N/A
DRIVE ASSEMBLY	29-29003-01	6	26
DRIVE ASSEMBLY, FACE-UP DELIVERY	RG1-1833-000	3	29
Deflector	RA1-7626-000	3	1
Diode, AM01A	RH6-3097-000	8	55
Diode, SHV-02	RF1-2494-000	8	35
Diode, SHV-02	WA1-1124-000	3	27D
Documentation, User (English)	EK-D1100-DK	1	Not Shown
Drive Assembly, Drum	RG1-1777-000	6	10
EEPROM, Serial (Not Shown)	21-23613-04	15	6
Eliminator, Static Charge	RA1-7600-000	8	19
FEEDER ASSEMBLY	29-29004-01	1	12
FEEDER ASSEMBLY	29-29004-01	13	N/A
FEEDER ASSEMBLY	29-29004-01	6	25
FEEDER ASSEMBLY, CASSETTE	N/A	1	24
FEEDER ASSEMBLY, CASSETTE	N/A	16	N/A
FIXING ASSEMBLY (100/115V)	29-29014-01	1	14
FIXING ASSEMBLY (100/115V)	29-29014-01	3	34
FIXING ASSEMBLY (100/115V)	29-29014-01	8	N/A
FIXING ASSEMBLY (220/240V)	29-29020-01	1	14
FIXING ASSEMBLY (220/240V)	29-29020-01	3	34
FIXING ASSEMBLY (220/240V)	29-29020-01	8	N/A
Fan, 2.64W DC 12V	29-29009-01	5	11
Foot	RA1-7453-000	7	5
Foot, Rubber	XH9-0059-000	7	7
Frame	RF1-3093-000	8	1
GUIDE ASSEMBLY, TRANSFER	RG9-0681-000	3	2
Gear, 107T/17T	RS1-0277-000	10	4
Gear, 13T	RS1-0303-000	14	7
Gear, 14T	RS1-0288-000	3	29C
Gear, 14T	RS1-0305-000	3	28E
Gear, 15T	RS1-0283-000	13	7
Gear, 15T	RS1-0304-000	3	29D
Gear, 15T	RS1-0306-000	3	28D
Gear, 17T	RS1-0296-000	16	17

INDEX BY PART DESCRIPTION

DEClaser 1100/1152

DESCRIPTION	DEC PART NO.	FIG. NO.	ITEM NO.
Gear, 20T	RS1-0291-000	3	22
Gear, 25T	RS1-0281-000	13	6
Gear, 27	RS1-0292-000	3	31
Gear, 27T/21T	RS1-0287-000	8	36
Gear, 30T	RS1-0284-000	6	4
Gear, 30T	RS1-0290-000	3	5
Gear, 33T/19T	RS1-0295-000	16	16
Gear, 34T	RS1-0299-000	16	20
Gear, 37T	RS1-0297-000	16	18
Gear, 39T	RS1-0298-000	16	19
Gear, 86T	RS1-0276-000	10	3
Guide	RF1-2496-000	3	2E
Guide, Cassette	RA1-7666-000	16	13
Guide, Cord	RA1-7579-000	3	27C
Guide, Entrance	RA1-7594-000	8	13
Guide, Font	RA1-7542-000	15	3
Guide, I/O	RA1-7536-000	7	2
Guide, Paper	RA2-0876-000	4	2
Guide, Paper Delivery	RF1-2495-000	8	20
Guide, Roller	RA1-7821-000	16	29
Guide, Sheet	RA1-7625-000	3	7A
Guide, Slide	RA1-7549-000	4	11
Heater, Halogen (100/115V)	RH7-4032-000	8	41
Heater, Halogen (220/240V)	RH7-4033-000	8	41
Holder, Cord	RA1-7637-000	3	18
Holder, Diode	RA1-8246-000	8	34
Holder, Left Connector	RA1-7596-000	8	15
Holder, Right Connector	RA1-7595-000	8	14
Inlet Assembly, Power (100/115V)	29-29006-01	1	7
Inlet Assembly, Power (220/240V)	29-29021-01	1	7
Interface Assembly	RG1-1823-000	1	18
Interface Assembly (DEClaser 1100)	29-29013-01	7	23
Interface Assembly (DEClaser 1152)	29-30383-01	7	24
KIT, PostScript UPGRADE (2 MB Mem)	LN07U-UA	1	Not Shown
KIT, PostScript UPGRADE (VMS SWL)	LN07R-UA	1	Not Shown
Kit, Toner/Supplies Cartridge	LN07X-AA	1	Not Shown
Label	RS1-8790-000	5	1C
Label	RS1-8805-000	18	16B
Label	RS1-8805-000	19	15B
Label	RS1-8836-000	18	16B
Label	RS1-8837-000	19	15C
Label	RS1-8842-000	17	14B
Label	RS1-8843-000	17	14C
Label, Caution	RS1-8839-000	19	15D
Label, Size	RS1-8805-000	19	15A
Label, Size (A4)	RA2-0893-000	17	14A
Label, Size (EXE)	RS1-8799-000	18	16A
Label, Size (LGL)	RA2-0895-000	17	14A
Label, Size (LTR)	RS1-8797-000	18	16A
Laser Assembly	29-29000-01	6	13
Lens Assembly	29-29002-01	6	15

INDEX BY PART DESCRIPTION

DEClaser 1100/1152

DESCRIPTION	DEC PART NO.	FIG. NO.	ITEM NO.
Lever	RA1-8231-000	9	7
Lever, Delivery Sensor	RA1-7588-000	8	8
Lever, Paper Sensor	RA1-7562-000	3	14
Lever, Sensor	RA1-7474-000	13	4
Lever, Shutter	RA1-7482-000	11	2
Module Assembly, AC Controller (100/115V)	RG1-1835-000	1	21
Module Assembly, AC Controller (220/240V)	RG1-1836-000	1	21
Module Assembly, Cassette Feeder	29-28998-01	1	25
Module Assembly, Cassette Feeder	29-28998-01	16	28
Module Assembly, DC Controller	29-28997-01	1	15
Module Assembly, DC Controller	29-28997-01	7	21
Module Assembly, Density Adjusting	29-29008-01	1	20
Module Assembly, Density Adjusting	29-29008-01	5	12
Module Assembly, Fixing AC	RG1-1602-000	3	26
Module Assembly, H.V. Power Supply	29-28999-01	1	23
Module Assembly, H.V. Power Supply	29-28999-01	7	22
Module Assembly, Interface	29-29013-01	1	19
Module Assembly, RAM-C	LN07X-MC	1	28
Module Assembly, RAM-V	LN07X-MA	1	27
Module Assembly, ROM	SG5-4115-000	1	17
Module Assembly, Video Controller	29-29018-01	1	16
Module Assy, Video Controller (DEClaser 1100)	29-29018-01	15	5
Module Assy, Video Controller (DEClaser 1152)	29-30382-01	15	5
Module, 1 MB Daughter Board Add-On (12-34857-01)	LN07X-UE	1	Not Shown
Module, Memory Option 2 MB RAM (DEClaser 1152 Only)	LN07X-UF	1	Not Shown
Motor Assembly, Scanner	29-29001-01	6	14
Motor, Main Stepping DC 4W	29-29010-01	6	7
MOUNT ASSEMBLY, LEFT TR ROLLER	RG1-1793-000	3	12
MOUNT ASSEMBLY, RIGHT TR ROLLER	RG1-1794-030	3	13
Mount, Module	RA1-7538-000	15	1
Mount, (PCB) Module	RA1-7663-020	16	10
Mount, Left FD Cover	RA1-7616-000	14	8
Mount, PCB (Module)	RA1-7533-000	7	11
Mount, Plate Contact	RA1-7476-000	9	1
Mount, Positioning	RA1-7552-000	7	12
Mount, Rod	RA1-7563-000	3	21
Mount, Sensor	RA1-7570-000	3	27B
Mount, Sensor	RA1-7662-000	16	9
Mount, Solenoid	RA1-7665-000	16	12
Mounting, Rear Cover	RA1-7551-000	4	5
Nut, Push	XA9-0134-000	8	56
PAD ASSEMBLY	RF1-2599-000	19	13
Pad	RA1-8227-000	5	1B
Pad	RA1-8365-000	19	13A
Pad, Separation	29-29007-01	6	9
Panel, Control (DEClaser 1152)	29-30569-01	4	6
Panel, Control (DEClaser 1100)	29-29017-01	4	6
Panel, Front	N/A	3	20
Panel, Left	RA2-0877-000	2	2
PANEL, REAR	RF1-3171-000	2	3
Panel, Right	RA2-0878-000	2	1

INDEX BY PART DESCRIPTION

DEClaser 1100/1152

DESCRIPTION	DEC PART NO.	FIG. NO.	ITEM NO.
PANELS/EXTERNAL COVERS, ETC.	N/A	1	1
PANELS/EXTERNAL COVERS, ETC.	N/A	2	N/A
Photo-Interrupter	WG8-0291-000	13	10
Photo-Interrupter	WG8-0291-000	16	26
Photo-Interrupter	WG8-0323-000	3	27A
Photo-Interrupter TLP1230	WG8-0291-000	5	10
Pin Assembly, 3P	RH2-5105-000	3	27E
Pin, Dowel	XD9-0103-000	13	13
Pin, Dowel	XD9-0108-000	12	6
Pin, Dowel	XD9-0111-000	15	9
Pivot	RA1-7499-000	6	12
Pivot	RA1-7704-000	17	8
Pivot	RA1-7704-000	18	9
Pivot	RA1-7704-000	19	9
Plate	RA1-7473-000	13	3
Plate	RA1-7702-000	17	6
Plate	RA1-7702-000	18	17
Plate	RA1-8234-000	3	2C
Plate	RF1-2600-000	19	14
PLATE ASSEMBLY, MACHINE BOTTOM	N/A	1	6
PLATE ASSEMBLY, MACHINE BOTTOM	N/A	7	N/A
Plate A, Grounding	RA1-7565-000	3	15
Plate B, Grounding	RA1-7566-000	3	16
Plate, Blanking	RA1-7510-000	8	46
Plate, Cable	RA1-8264-000	8	53
Plate, Cable	RA1-8264-000	8	54
Plate, Cable No. 1	RA1-7608-000	8	26
Plate, Cable No. 2	RA1-7609-000	8	27
Plate, Claw	RA1-7698-000	17	2
Plate, Claw	RA1-7698-000	18	3
Plate, Contact	RA1-8232-000	9	8
Plate, Contact (D)	RA1-7480-000	9	5
Plate, Contact (P)	RA1-7479-000	9	4
Plate, Contact (T)	RA1-7478-000	9	3
Plate, Continuity	RA1-8245-000	8	33
Plate, Continuity No. 1	RA1-7617-000	8	29
Plate, Continuity No. 2	RA1-7618-000	8	30
Plate, Continuity No. 3	RA1-7619-000	8	31
Plate, Continuity No. 4	RA1-7620-000	8	32
Plate, Drive	RFI-2393-000	10	7
Plate, Drum Contact	RA1-7477-000	9	2
Plate, End Length Adjustment	RA1-8363-000	19	2
Plate, End Width Adjustment	RF1-2598-000	19	12
Plate, Grounding	RA1-7456-000	5	3
Plate, Grounding	RA1-7463-000	10	1
Plate, Grounding	RA1-7639-000	6	19
Plate, Grounding	RA1-7716-000	3	28C
Plate, Grounding	RA1-7816-000	7	9
Plate, Grounding	RA1-7825-000	3	2A
Plate, Grounding (2)	RA1-7811-000	5	7
Plate, Hook Shaft	RA1-8255-000	3	17
Plate, Insulating	RA1-7730-000	8	50
Plate, Left Cable	RA1-7589-000	8	9

INDEX BY PART DESCRIPTION

DEClaser 1100/1152

DESCRIPTION	DEC PART NO.	FIG. NO.	ITEM NO.
Plate, Left Hook	RA1-7593-000	8	12
Plate, Left Hook	RA2-0767-000	8	12
Plate, Left Lifting	RA1-7598-000	8	17
Plate, Left Mounting	RA1-7528-000	4	3
Plate, Length Adjustment	RA1-7693-000	18	1
Plate Nut, Left	RA1-7459-000	5	6
PLATE, PAPER GUIDE	RF1-2400-050	3	7
PLATE, PAPER LIFTING	RF1-2597-000	19	11
PLATE, PAPER LIFTING (EXE)	RF1-2425-000	18	14
PLATE, PAPER LIFTING (LGL)	RF1-2424-000	17	13
PLATE, PAPER LIFTING (LTR)	RF1-2424-000	18	14
PLATE, PAPER LIFTING(A4)	RF1-2422-000	17	13
Plate, Paper Support	RA1-7550-000	4	4
Plate, Retainer	RA1-7483-000	11	3
Plate, Right Cable	RA1-7591-000	8	10
Plate, Right Hold-down Tab	RA1-8358-000	19	1
Plate, Right Hook	RA1-7592-000	8	11
Plate, Right Lifting	RA1-7599-000	8	18
Plate, Right Mounting	RA1-7532-000	4	7
Plate, Sensor Mounting	RA2-0762-000	5	2
Plate, Size	RF1-2426-000	17	15
Plate, Size	RF1-2426-000	18	14B
Plate, Stack-End	RA1-7535-000	7	1
Plate, Tray Stopper	RA1-7507-000	6	3
Power Inlet Assembly (100/115V)	29-29006-01	7	25
Power Inlet Assembly (220/240V)	29-29021-01	7	25
Rack	RA1-7484-000	11	4
Rail	RA1-7544-000	15	4
Resistor, 68M OHM, 1/2W	RH6-3091-000	3	2D
Retainer, TR Left	RA1-7621-000	3	12A
Retainer, TR Right	RA1-7622-020	3	13A
Ring	RA1-7560-000	2	3B
Ring	RA1-7660-000	16	7
Ring (A), Ratchet	RA1-7656-000	16	3
Ring (B), Ratchet	RA1-7658-000	16	5
Ring, E	XD9-0101-000	17	16
Ring, E	XD9-0101-000	18	17
Ring, E	XD9-0101-000	19	10
Ring, Idler	RA1-7578-000	12	4
Rod	RA1-7703-000	17	7
Rod	RA1-7703-000	18	8
Rod	RA1-7703-000	19	8
Rod	RF1-2502-000	11	1
ROD ASSEMBLY	RG1-1781-000	1	10
ROD ASSEMBLY	RG1-1781-000	11	N/A
ROD ASSEMBLY	RG1-1781-000	6	24
Rod, Latch	RA1-7603-000	8	22
Rod, Latch	RA2-0766-000	8	22
Rod, Roller	RA1-7700-000	17	4
Rod, Roller	RA1-7700-000	18	5
Rod, Roller	RA1-8367-000	19	4

INDEX BY PART DESCRIPTION

DEClaser 1100/1152

DESCRIPTION	DEC PART NO.	FIG. NO.	ITEM NO.
Roller	RA1-7575-000	12	3
Roller	RA1-7699-000	17	3
Roller	RA1-7699-000	18	4
Roller	RA1-8366-000	19	3
ROLLER ASSEMBLY, TRAY PICK-UP	29-29005-01	1	11
ROLLER ASSEMBLY, TRAY PICK-UP	29-29005-01	12	N/A
ROLLER ASSEMBLY, TRAY PICK-UP	29-29005-01	3	33
Roller, Delivery	RA1-7708-040	14	4
Roller, Delivery	RA1-7714-000	3	28B
Roller, Delivery	RF1-2491-000	3	8
Roller, Lower Fixing	RA1-7583-000	8	3
Roller, Paper Feed	RF1-2394-000	13	11
Roller, Pick-Up	RA1-7573-000	12	1
Roller, Pick-Up	RA1-7674-000	16	15
Roller, Pick-Up	RA1-7824-000	16	30
Roller, Transfer	29-28994-01	3	30
Roller, Upper Fixing	RF1-2505-000	8	2
Screw	XA9-0516-000	4	14
Screw,	XA9-0535-000	4	12
Screw, M3	RA9-0603-000	7	6
Screw, M3	XA9-0494-000	16	27
Screw, M3 x 10	XA9-0475-000	4	13
Screw, M3 x 6	XA9-0233-000	8	47
Screw, M3 x 6	XB2-7300-607	8	48
Screw, M3 x 6 (TP)	XA9-0267-000	7	17
Screw, M3 x 6 (TP)	XA9-0267-000	8	38
Screw, M3 x 6 (TP)	XB5-6300-509	10	8
Screw, M3 x 8 (TP)	XA9-0302-000	7	20
Screw, Machine Truss Head M3 x 10	FA9-1643-000	6	22
Screw, Machine Truss Head M3 x 10	XA9-0462-000	6	18
Screw, Machine Truss Head M3 x 16	XA9-0459-000	6	17
Screw, Machine Truss Head M3 x 4	FB1-2267-000	17	12
Screw, Machine Truss Head M3 x 4	FB1-2267-000	18	13
Screw, Machine Truss Head M3 x 8	XA9-0259-000	6	20
Screw, Machine Truss Head M3 x 8	XA9-0259-000	7	18
Screw, Machine Truss Head M4 x 10	XA9-0497-000	6	21
Screw, Stepped M3	RA1-7636-000	8	40
Screw, Stepped M3	RA1-7803-000	8	51
Screw, Stepped M3	RA9-0621-000	3	11
Screw, Stepped M3	RA9-0621-000	7	3
Screw, TP M3 x 10	XA9-0495-000	2	3A
Screw, TP M3 x 12	XA9-0382-000	3	6
Screw, w/Washer M3 x 16	XA9-0488-000	6	6
Screw, w/Washer M3 x 6	XA9-0500-000	7	16
Screw, w/Washer M3 x 8	XA9-0498-000	7	19
Screw, w/Washer M3 x 8	XB2-7300-807	3	10
Screw, w/Washer M4	XA9-0499-000	7	24
Shaft	RA1-7715-000	3	29B
Shaft, Drive	RA1-7470-000	13	2
Shaft, Feed Roller	29-28995-01	16	1
Shaft, Pick-Up Roller	29-28996-01	16	2
Sheet	RA1-7706-000	17	13B
Sheet	RA1-7706-000	18	14B

INDEX BY PART DESCRIPTION

DEClaser 1100/1152

DESCRIPTION	DEC PART NO.	FIG. NO.	ITEM NO.
Sheet	RA1-7818-000	5	1A
Sheet	RA1-8265-030	8	1A
Sheet, Friction (A4)	RA1-7689-000	17	13A
Sheet, Friction (EXE)	RA1-7692-000	18	14A
Sheet, Friction (LGL)	RA1-7691-000	17	13A
Sheet, Friction (LTR)	RA1-7691-000	18	14A
Sheet, Insulation	RA1-8260-000	8	49
SHUTTER ASSEMBLY	RG1-1773-040	6	16
Slider	RA2-0081-000	4	10
Slider, Print Density	RA1-8262-000	5	4
Solenoid, DC 24V	RH7-5025-000	16	25A
Solenoid, DC 24V	RH7-5026-000	16	25B
Spring (A), Clutch	RA1-7657-000	16	4
Spring (B), Clutch	RA1-7659-000	16	6
Spring, Compression	RS1-2237-000	13	9
Spring, Compression	RS1-2241-000	8	37
Spring, Compression	RS1-2242-000	3	12C
Spring, Compression	RS1-2242-000	3	13C
Spring, Compression	RS1-2244-000	3	9
Spring, Compression	RS1-2254-000	16	31
Spring, Grounding Leaf	RA1-7604-030	8	23
Spring, Leaf	RA1-7569-000	14	1
Spring, Leaf	RA1-7585-020	8	5
Spring, Leaf	RA1-7664-000	16	11
Spring, Leaf	RA1-7696-000	17	1
Spring, Leaf	RA1-7696-000	18	2
Spring, Leaf	RA1-7701-000	17	5
Spring, Leaf	RA1-7701-000	18	6
Spring, Leaf	RA1-7828-000	8	39
Spring, Leaf	RA1-8368-000	19	5
Spring, Leaf	RF1-3095-000	8	24
Spring, Tension	RS1-2234-000	6	16E
Spring, Tension	RS1-2235-000	10	5
Spring, Tension	RS1-2236-000	13	8
Spring, Tension	RS1-2238-000	11	6
Spring, Tension	RS1-2239-000	11	7
Spring, Tension	RS1-2248-000	14	3
Spring, Tension	RS1-2251-000	17	10
Spring, Tension	RS1-2252-000	17	11
Spring, Tension	RS1-2253-000	3	25
Spring, Tension	RS1-2265-000	19	6
Spring, Tension	RS1-2266-000	19	7
Spring, Tension (EXE)	RS1-2247-000	18	12
Spring, Tension (LTR)	RS1-2251-000	18	10
Spring, Tension (LTR)	RS1-2252-000	18	11
Spring, Thermistor Leaf	RA1-7602-000	8	21
Spring, Torsion	RA1-7607-000	8	25
Spring, Torsion	RA1-7718-000	3	24
Spring, Compression	RS1-2255-000	8	52
Strip, Friction	RA1-8357-000	19	11A
Support, Left Roller	RA1-7710-000	14	6
Support, PCB (Module)	VT2-0016-004	7	15
Support, Plate (EXE)	RA1-7823-000	18	18

INDEX BY PART DESCRIPTION

DEClaser 1100/1152

DESCRIPTION	DEC PART NO.	FIG. NO.	ITEM NO.
Support, Right Roller	RA1-7709-000	14	5
Support, Roller	RA1-7611-000	3	29A
Support, Roller	RA1-7822-000	3	28F
Switch, Rocker	RH7-6016-000	7	10
Tape	RA9-0689-000	3	32
Thermoswitch (Cont)	RF1-2483-020	8	42
Thermoswitch (NOC)	RF1-2484-020	8	43
Tie, Cable	WT2-0389-000	6	11C
Tie, Cable	WT2-0505-000	5	9
Tray Assembly, Multi-Purpose	29-29019-01	2	5
Tray, A4 Size Paper Input	LN07X-TA	1	Not Shown
Tray, Face-Up	RA1-7630-080	2	4
Tray, Large Capacity Letter Size Paper	LN07X-TG	1	Not Shown
Washer, Wave	XD9-0079-000	8	16