

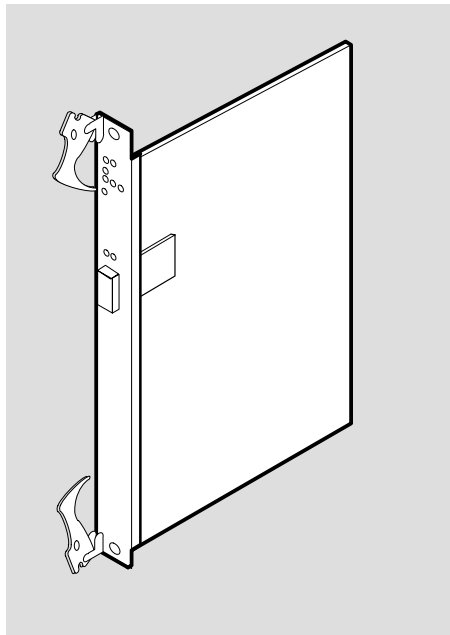

ATM 1-Port 622 Mb/s MMF Line Card DAGGL-CA July 1996

This document contains information critical to the use of the 622 Mb/s SONET/SDH ATM line card (DAGGL-CA) with one multimode fiber (MMF) port. Read the system documentation and this document before installing and using this line card.



LKG-10160-96I

The DAGGL-CA is a member of the line card family of logic modules that supports one MMF port. The line card performs ATM cell-forwarding functions among a set of connected ATM links. This line card implements one port using an OC-12 (622 Mb/s) link and connects this port to the crossbar module.

The DAGGL-CA uses MMF cables that adhere to these specifications.

- EIA/TIA 492-AAAA
- 62.5/125 μm
- SC connector
- 0 through 500 m
- 0 through 6 dB loss

Supported Firmware Versions

The line card requires firmware V2.0 release as a minimum. Check the firmware release notes to make sure that you have the latest versions of the line card images and CMM firmware (at least Version 1.74).

NOTE: You must have CMM Version 1.74 or later to use this firmware.

New versions of software images for the GIGAswitch/ATM system are available on the Internet from the Digital FTP site (<ftp.digital.com>). The `/pub/DEC/GIGAswitchATM` directory contains the latest release information for the GIGAswitch/ATM firmware. The `READ_ME.TXT` file in the above directory contains pointers to the latest software images and firmware release notes. After connecting to the Master line card, check the versions of the ROM and the application image using the `versions` command to determine whether a firmware upgrade is necessary.

NOTE: All line cards in the same switch must be at the same firmware revision level.

Installing the Line Card

To install or remove the line card, follow the instructions for installing or replacing logic modules as described in your system's Installation and Service manual. That document also provides you with information about the proper slot positions for the line cards, including the Master line card.

Before installing the line card in your system, install the power module that you need to use as described in the Installing the DC-to-DC Power Module section of this document.

Testing the Line Card

This section helps you evaluate the results of the module self-test (MST) by identifying each light-emitting diode (LED) and describing its purpose.

Each line card contains two sets of LEDs. The LED at the top of the module is called the Module LED, the LED below the Module LED (labeled 1) is called the Link LED, the set of three LEDs below the Link LED (labeled i) are called Information LEDs, and the two LEDs above the port are called Physical layer (PHY) LEDs.

The PHY LEDs display Physical layer information. The two PHY LEDs are the Port Status LED (left LED above the port) and the FRU (field-replaceable unit) LED (right LED above the port).

The Module LED (topmost LED) displays the mode for the line card. When the Module LED is green, the line card is operational and the Link LED displays the status of the line and the type of end node [an ATM end node (UNI) or an ATM switch (NNI)] connected at the remote end. The end node information (switch versus end node) is intended to help the system manager connect cables. When the Module LED is amber, the Link LED and Information LEDs display information about self-test failures that occur when booting the line cards.

The transmit line uses the lower fiber receptacle and the receive line uses the upper fiber receptacle of the port.

You can perform a simple loopback test for the port on a line card by connecting a fiber-optic loopback connector between the transmit and receive lines when the Module LED is solid green to see whether the Link LED lights up. When you make the connection, the Link LED should turn flashing green briefly. It should then turn solid green briefly before turning flashing amber.

If you have more than one DAGGL-CA line card in your switch, you can perform a simple loopback test for the ports on two line cards by connecting a fiber-optic cable between the transmit line (the lower line of the port) of port 1 to the receive line (the upper line of the port) of port 2 to see whether the Port Status LED and the Link LED light up. When you make this connection, the Port Status LED for port 1 should turn solid green. The Link LED should briefly turn flashing green and then briefly turn solid green before turning flashing amber. When you connect the receive line of port 1 to the transmit line of port 2, the LEDs for port 2 should also display the same sequence of LED indications.

Figure 1 shows the LEDs and Table 1 describes the meaning of each LED condition for the ATM 1-port 622 Mb/s line card.

Figure 1: LEDs for 1-Port 622 Mb/s Line Card

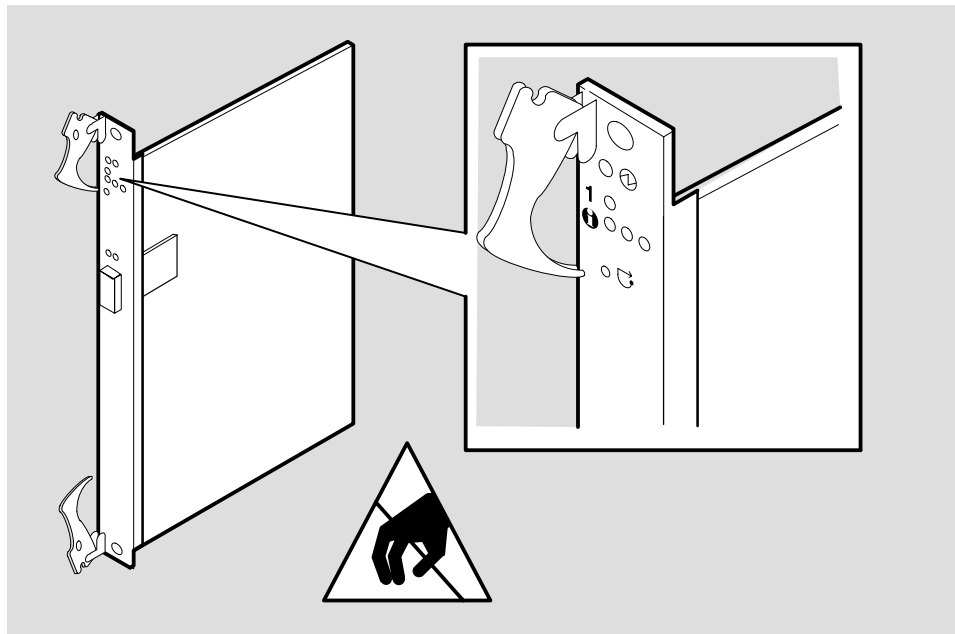

LKG-10160-96I

Table 1: LED Conditions

LED Condition	Meaning
The topmost or Module LED displays the mode for the four LEDs below it as follows:	
Off	Module is powered down.
Flashing Green	System initialization is in progress. The Link LED and Information LEDs display the progress of the firmware load as described in Table 2.
Flashing Amber	Self-test is in progress.
Green	Self-test completed successfully. The line card is in operational state. The Link LED displays the link status for the port as described in Table 3.
Amber	Self-test has completed and an error was detected. The Link LED and Information LEDs display diagnostic codes as described in the Using the Diagnostic LEDs section of this document.
The left or Port Status LED above the link displays the following information:	
Off	Port is waiting for a connection.
Green	Port is active (connected, with link established).
Flashing Green	Port is disabled by management.
Amber	Port is receiving photons, but the line is not up.
The right or FRU LED above the link displays the following information:	
Amber	PHY card has a hardware fault.
Off	Normal state.

When the Module LED flashes green, it indicates that the line card is loading firmware. The LEDs indicate the load progress as described in Table 2. (The Link LED is LED 1 and the three Information LEDs are LED 2 through LED 4 from left to right.)

Table 2: LED Indications of Firmware Load Progress

LED 1	LED 2	LED 3	LED 4	Condition
Amber	Off	Off	Off	Bootp request timed out and response was not received.
Green	Off	Off	Off	Bootp successful and response was received.
Green	Amber	Off	Off	Kernel image download was attempted and failed.
Green	Green	Off	Off	Kernel image download succeeded.
Green	Green	Amber	Off	Application image download was attempted and failed.
Green	Green	Green	Off	Application image download succeeded.
Green	Green	Green	Amber	Decompression of application image to RAM failed; application image version does not match kernel version.
Green	Green	Green	Green	Application image has loaded from Flash to RAM.

After all the LEDs turn green to indicate that the application image has loaded from the Flash to the RAM, application initialization starts. The Module LED turns green and the remaining four LEDs turn off. After the application initialization is complete, the Module LED stays green and the Link LED indicates the link status described in Table 3.

Table 3: LED Indications of Link Status

LED Condition	Meaning
Flashing Green	Testing is in progress; Receive signal is present.
Solid Green	Testing has completed; Receive and Transmit signals are synchronized. Line error rate is less than the threshold.
Flashing Amber	Remote end node is a Digital switch. If a loopback cable is connected between two ports on the same switch, the LEDs stay flashing amber.
Solid Amber	Established that remote end is a Digital switch (other than itself).

Using the Diagnostic LEDs

When the Module LED is amber, the four LEDs below it are used to report self-test failures when booting the line cards. These LEDs indicate the failures listed in Table 4. (The Link LED is LED 1 and the three Information LEDs are LED 2 through LED 4 from left to right.)

Table 4: LED Indications for Diagnostics

LED 1	LED 2	LED 3	LED 4	Condition
Off	Off	Amber	Off	Boot ROM corrupted
Off	Off	Off	Amber	CPU fail 1
Off	Off	Off	Green	CPU fail 2
Off	Off	Amber	Amber	RAM fail
Off	Off	Green	Off	Bad UART 1
Off	Off	Green	Amber	Bad UART 2
Off	Off	Green	Green	Ethernet problem
Amber	Off	Amber	Amber	Xilinx load failed
Amber	Amber	Off	Off	Queue RAM failed
Amber	Amber	Off	Amber	Queue RAM failed
Amber	Amber	Off	Green	Cell RAM failed
Amber	Green	Off	Off	Credit RAM fail 1
Green	Off	Off	Amber	Credit RAM fail 2

Installing the DC-to-DC Power Module

The line card uses one of two power modules, depending on the system that you are installing it in. Line cards used in the GIGAswitch/ATM 14-slot system must have the 48V power module option (DAGPL-AB). Line cards used in the GIGAswitch/ATM 5-slot system must have the 5V power module option (DAGPL-AA).

NOTE: Failure to install the correct power module option for use in your system will result in an inoperational line card.

Refer to Figure 2 (which shows the 48V option) when following these steps to install either power module.

1. Align the pins on the power module with the mating sockets on the line card. The DAGPL-AB option has one end with seven pins that are closer to the front of the line card. The DAGPL-AA option has one end with a pin offset from the others that is closer to the front of the line card.
2. Press the power module firmly into place while supporting the line card.

NOTE: Be careful not to damage surrounding components when installing these power modules.

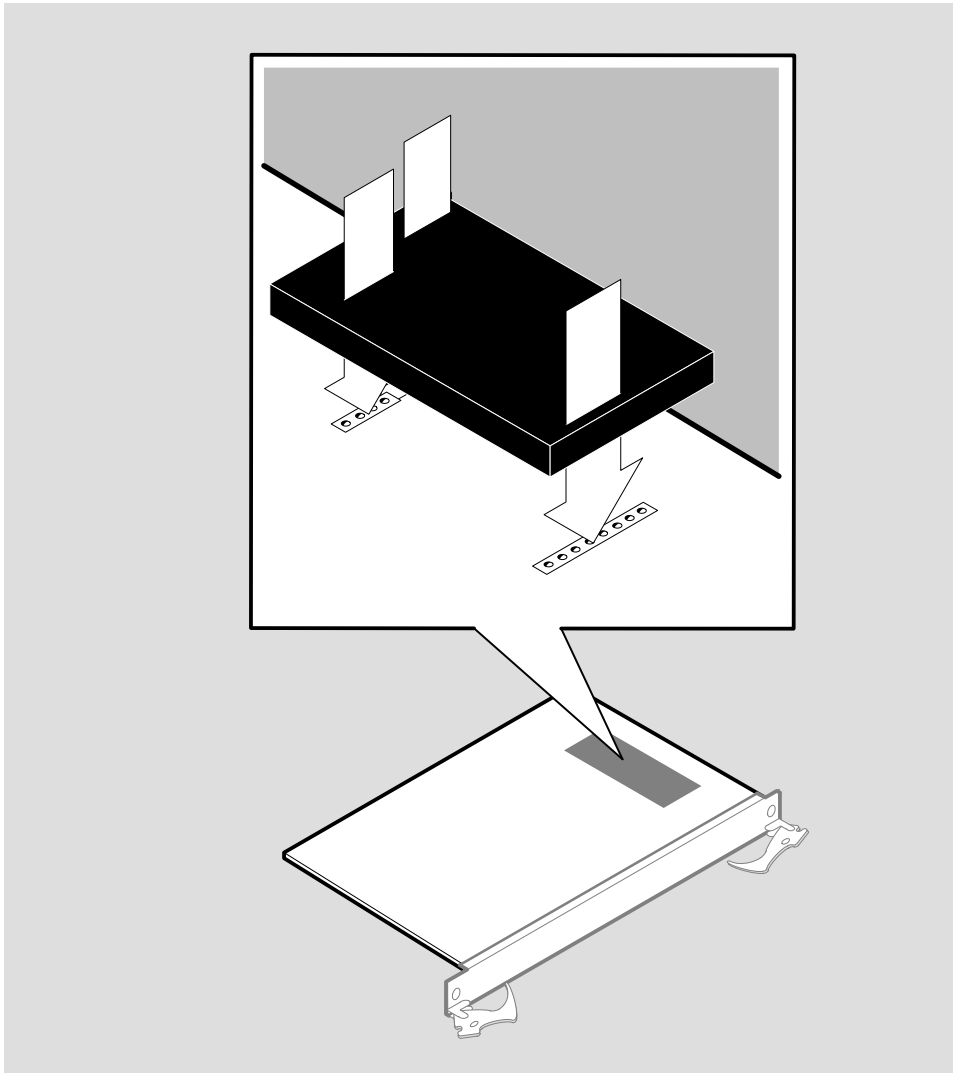
Figure 2: Installing the DC-to-DC Power Module

LKG-10162-961

Removing the 48V Power Module Option

Follow these steps to remove the 48V power module option (DAGPL-AB).

1. Carefully place a thin flat blade screwdriver between the power module and the line card on the inner edge of one set of pins.
2. GENTLY insert the screwdriver without touching the line card surface so that the power module is eased away from the line card.

NOTE: Do not insert the screwdriver more than 2.54 cm (1 in).

3. Repeat steps 1 and 2 for the other set of pins.

4. Gently pull the power module off the line card.

Removing the 5V Power Module Option

Follow these steps to remove the 5V power module option (DAGPL-AA).

1. Carefully grasp the edges of the power module and ease the power module away from the line card.
2. GENTLY pull the power module off the line card.

Copyright © Digital Equipment Corporation 1996. All rights reserved. Printed in U.S.A.

The following are trademarks of Digital Equipment Corporation: GIGAswitch and the DIGITAL logo.