



Storage Area Network Performance Testing SmartFabric™

Product Overview

SmartBits® SmartFabric™ is specifically designed to measure the quality of service of storage area networks (SANs) and storage devices. As storage networks and devices continue to grow in complexity, the importance of testing the overall performance of each individual device and the entire network also increases. Data storage is playing a large role in today's market and end users are expecting their storage networks to meet certain performance criteria. Users have definite expectations of what the overall latency, throughput, and frame loss measurements of their networks should be. SmartFabric assists users in measuring these types of test metrics.

All devices are not created equal. Fibre channel is a very complex protocol. The way that devices handle buffer-to-buffer credits, fabric services, and queuing can greatly affect the way a device performs. In addition, the way in which the ports, backplane, and buffers of a device are designed can greatly affect the device's performance. As devices are networked together, issues arise regarding fairness algorithms across ISLs and failover time across optic links. It is important that users have a complete understanding of the entire network and how they can test important issues relevant to SANs. SmartFabric is designed to provide users with an easy way to test the metrics that matter most in a SAN environment.

SmartFabric contains "canned" test scenarios that allow users to test the total throughput, latency, frame loss, and failover time of a single device or an entire network. Multiple ports can be used to generate traffic and measure the performance of the entire system under test.

Real world test environments. SmartFabric is designed to allow users to test a device in the way that it will be used in the real world; that is, as a complete system. Storage network devices are built with multiple ports so that end users can use those multiple ports. SmartFabric is designed to allow users to create real-world traffic loads across all available device or network ports; not just across a single port. In this way, SmartFabric tests the way the device or network operates in the real world. By conducting multiple port tests during design and development, there are no surprises or unexpected network errors when devices or networks are actually implemented.

Test Descriptions

- **Throughput** – Measures the total throughput of a device, including per flow, per port, and complete per device measurements.
- **Frame Loss** – Measures if any frame loss occurs as data traverses various networks.
- **Latency** – Checks the minimum and maximum latency values for each individual flow.
- **Latency Distribution** – Creates a latency histogram that profiles the latency of the network.
- **Latency Snapshot** – Tracks the latency of individual frames to provide a granular picture of how a network performs.
- **Failover** – Measures how quickly ISLs recover after link failure and tracks any effects to the network's throughput and latency levels.

**Spirent
Communications**
26750 Agoura Road
Calabasas, CA
91302 USA
E-mail: productinfo
@spirentcom.com

Sales Contacts:
North America
+1 800-927-2660
**Europe, Middle East,
Africa**
+33-1-6137-2250
Asia Pacific
+852-2511-3822
All Other Regions
+1 818-676-2683

www.spirentcom.com

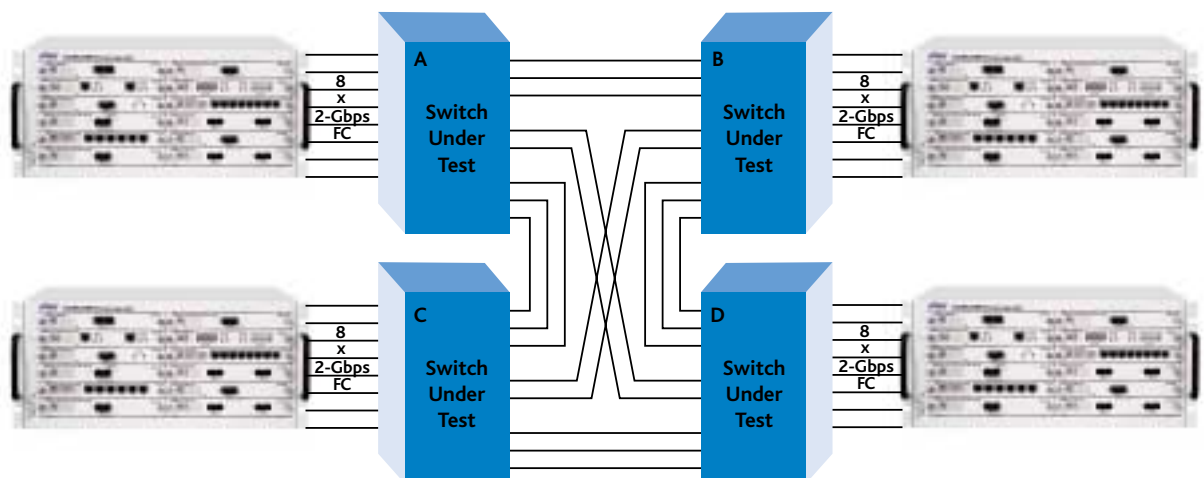

SmartFabric test applications

Test Scenarios

- Fibre Channel Switches
- Directors
- Large SAN Fabrics
- FCIP Gateways
- Optical Gateways
- 10 Gbps ISL Links

Key Features

- Full line-rate traffic generation and analysis at 1 and 2 Gbps.
- Generates up to 512 independent data streams.
- Supports point-to-point and loop (public and private) modes.
- Performs loop initialization, fabric login, and a name server for one or many devices.
- Emulates up to 126 loop devices per port.
- Sends various frame sizes for from 60 to 2148 bytes.
- Supports up to 192 Fibre Channel ports.
- Contains an easy-to-use test setup.

- Supports geographically-distributed testing via GPS synchronization.
- Reporting formats for test results include both graphical and tabular formats with multiple levels of detail.

System Requirements

- A SmartBits 600, 6000B, or 6000C chassis.
- At least one SmartBits FBC-3601A 1 Gbps Fibre Channel module or one FBC-3602A 1 Gbps/2 Gbps Fibre Channel module.
- An IBM or compatible Pentium PC computer running Windows 98/2000/NT, with mouse and color monitor.

Ordering Information

SWF-1229A

SmartFabric Fibre Channel/ SAN Performance Test Suite

SUS-SMB

12 Month Software Update Support Service

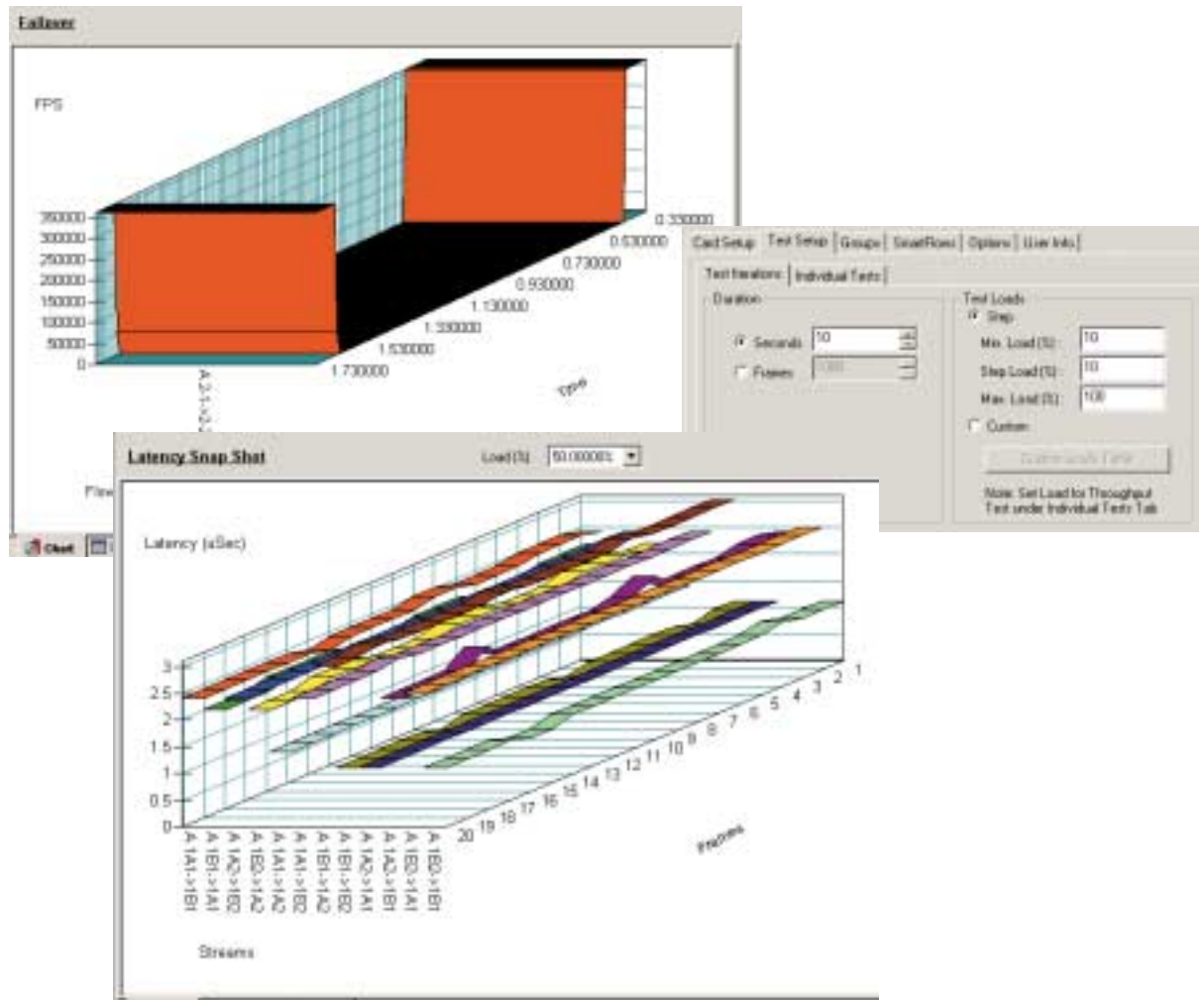

SmartFabric setup and test results windows

Spirent Communications
 26750 Agoura Road
 Calabasas, CA
 91302 USA
 E-mail: productinfo@spirentcom.com

Sales Contacts:
North America
 +1 800-927-2660
Europe, Middle East, Africa
 +33-1-6137-2250
Asia Pacific
 +852-2511-3822
All Other Regions
 +1 818-676-2683

www.spirentcom.com

