

Instruction Manual

GVSP30 Scroll Pump

Description

Item Number

GVSP30 Scroll Pump, 3-phase, 200/208/230/380-460 V, 50/60 Hz

A710-04-907

GVSP30 Scroll Pump, 1-phase, 100/115/200/230 V, 50/60 Hz

A710-04-909

This page intentionally blank.

CONTENTS

Section		Page
1	INTRODUCTION	1
1.1	Scope and definitions	1
1.2	Description	1
2	TECHNICAL DATA	3
2.1	Operating and storage conditions	3
2.2	Performance	3
2.3	Mechanical data	3
2.4	Gas-ballast supply (optional)	3
2.5	Noise and vibration data	3
2.6	Electrical data	4
2.7	Materials exposed to vacuum	4
3	INSTALLATION	7
3.1	Safety	7
3.2	System requirements	7
3.3	Unpack and inspect	7
3.4	Reconfigure the pump (optional)	8
3.5	Locate the pump	8
3.6	Connect the electrical supply	9
3.6.1	Introduction	9
3.6.2	Connect to 3-phase pumps	9
3.6.3	Connect to 1-phase pumps	9
3.7	Check the direction of motor rotation	12
3.8	Connect the pump inlet to the vacuum system	12
3.9	Connect the pump outlet	13
3.10	Configure the gas-ballast system (if necessary)	13
3.11	Leak test the pump installation	13
4	OPERATION	14
4.1	Start-up	14
4.2	Shut-down	14
5	MAINTENANCE	15
5.1	Safety information	15
5.2	Inspect the system	15
5.3	Inspect the inlet screen	16
5.4	Service	16
6	STORAGE AND DISPOSAL	17
6.1	Storage	17
6.2	Disposal	17

CONTENTS (CONTINUED)

Section		Page
7	SERVICE, SPARES AND ACCESSORIES	18
7.1	Introduction	18
7.2	Service	18
7.3	Spares	18
7.4	Accessories	18
	RETURN OF BOC EDWARDS EQUIPMENT	

ILLUSTRATIONS

Figure		Page
1	The GVSP30 pump (3-phase pump shown)	2
2	Pump dimensions (mm): 3-phase pump shown	5
3	Pumping speed/pressure graph ($\text{m}^3 \text{h}^{-1}$)	6
4	Pumping speed/pressure graph (cfm)	6
5	Motor terminal-box low-voltage configuration: 3-phase pumps	10
6	Motor terminal-box high-voltage configuration: 3-phase pumps	10
7	Motor terminal-box low-voltage configuration: 1-phase pumps	11
8	Motor terminal-box high-voltage configuration: 1-phase pumps	11

TABLES

Table		Page
1	Operating and storage conditions	3
2	Performance data	3
3	Mechanical data	3
4	Gas-ballast supply data	3
5	Noise and vibration data	3
6	Electrical data: general	4
7	Electrical data: 1-phase pumps	4
8	Electrical data: 3-phase pumps	4
9	Materials exposed to vacuum	4
10	Spares Item Numbers	18
11	Accessory Item Number	18

1 INTRODUCTION

1.1 Scope and definitions

This manual provides installation, operation and maintenance instructions for the BOC Edwards GVSP30 Scroll Pump. You must use the pumps as specified in this manual.

Read this manual before you install and operate your pump. Important safety information is highlighted as WARNING and CAUTION instructions; you must obey these instructions. The use of WARNINGS and CAUTIONS is defined below.

	<p>WARNING</p> <p>Warnings are given where failure to observe the instruction could result in injury or death to people.</p>
---	---

<p>CAUTION</p> <p>Cautions are given where failure to observe the instruction could result in damage to the equipment, associated equipment and process.</p>

The units used throughout this manual conform to the SI international system of units of measurement.

For displacement and pumping speed, the term 'cfm' is also used to mean ft³ min⁻¹.

The following warning labels are on the pump:



Warning - refer to accompanying documentation.



Warning - risk of electric shock.

1.2 Description

Refer to Figure 1. The GVSP30 is a compact, reliable vacuum pump designed for use on clean processes. The GVSP30 pump is **not** suitable for use with explosive, flammable, toxic or corrosive substances, or substances which contain particulates, or powders.

If you want to pump condensable vapours, or if you will regularly use the GVSP30 to pump down from atmospheric pressure in a humid environment (for example, if relative humidity exceeds 60%), you must use gas ballast (refer to Section 3.10).

Inlet gas temperatures should not exceed 50 °C. If you need to pump gases above this temperature, install a chiller in the foreline, otherwise premature failure of the pump may occur.

The body of the pump includes stationary scrolls (5) and an orbiting scroll. The orbiting scroll is driven by the electric motor through an eccentric cam on the motor drive shaft. The movement of the orbiting scroll, meshed with the stationary scrolls, forms successive crescent shaped volumes in the pump.

Gas which enters the pump through the inlet (2) is compressed by the movement of the orbiting scroll and swept towards the centre of the stationary scrolls. The compressed gas enters the exhaust-port near the centre of the stationary scrolls and is exhausted from the pump through the outlet (4).

The pump inlet (2) has an inlet screen which prevents the entry of debris into the pump.

The pump is air-cooled and has an electric motor and an hours counter (14) which operates when the electrical supply to the pump is switched on.

GVSP30 Scroll Pump

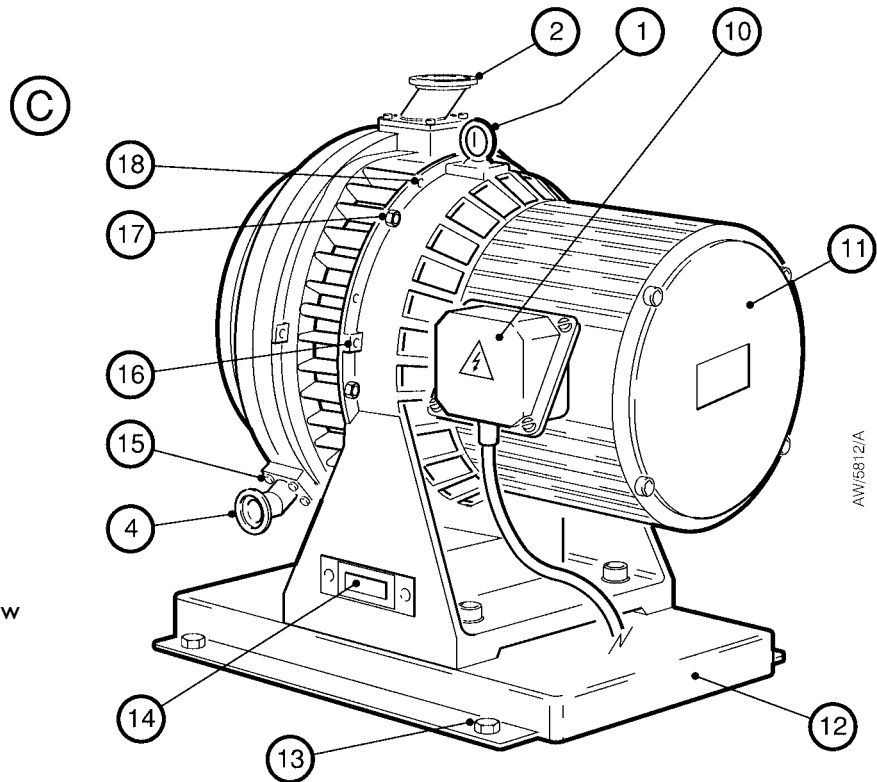
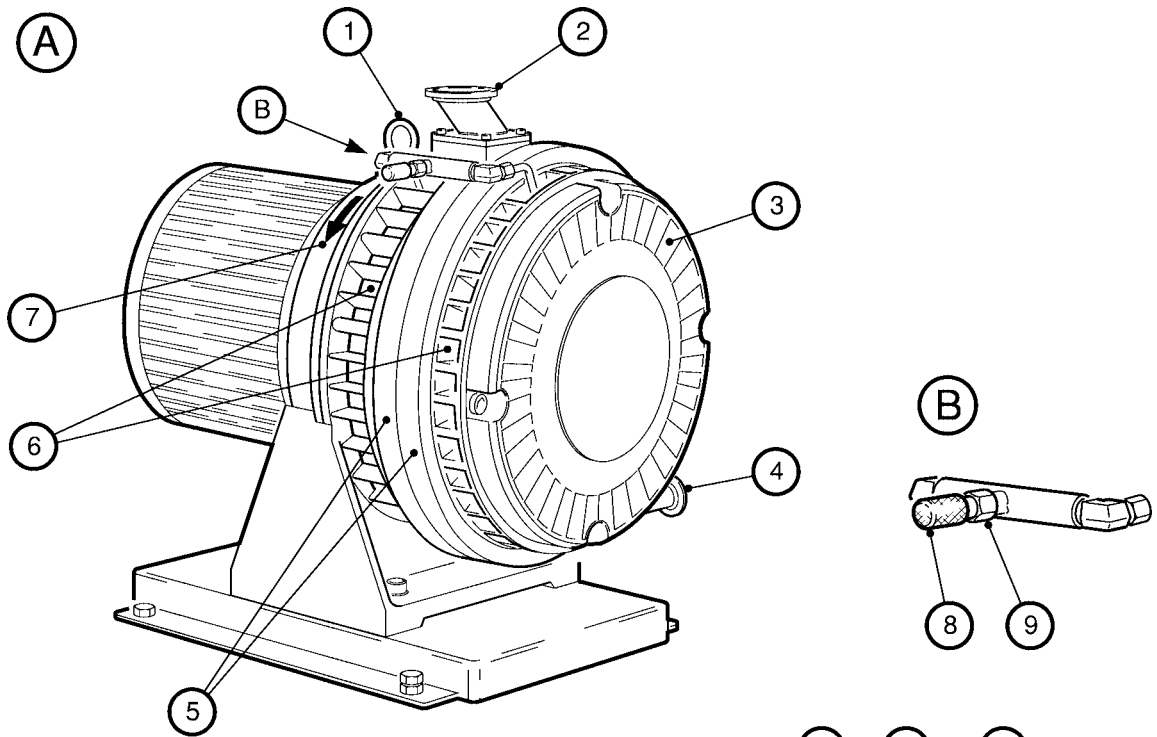

1. Lifting-eye
2. Inlet-port and inlet screen (in the inlet-port)
3. Fan cover
4. Outlet-port
5. Stationary scrolls
6. Cooling-fins
7. Direction of rotation arrow
8. Gas-ballast filter
9. Gas-ballast inlet
10. Motor terminal-box
11. Motor end-cover
12. Base-plate
13. Mounting-bolts (4 off)
14. Hours counter
15. Bolts (4 off)
16. Jacking holes
17. Coupling-cover bolts (5 off)
18. Location dowels (2 off)

AW/5812/A

Figure 1 - The GVSP30 pump (3-phase pump shown)

2 TECHNICAL DATA

2.1 Operating and storage conditions

Ambient operating temperature range	5 to 40 °C
Ambient storage temperature range	-20 to 60 °C

Table 1 - Operating and storage conditions

2.2 Performance

Ultimate pressure	1×10^{-2} mbar, 1 Pa
Maximum inlet pressure	1000 mbar, 1×10^5 Pa, 0 psig
Maximum outlet pressure	1150 mbar, 1.15×10^5 Pa, 2 psig
Leak tightness	$< 1 \times 10^{-4}$ mbar l s ⁻¹ , 1×10^{-2} Pa l s ⁻¹
Displacement (swept volume)	
50 Hz electrical supply	29.5 m ³ h ⁻¹ (17.4 cfm)
60 Hz electrical supply	35.1 m ³ h ⁻¹ (20.7 cfm)
Pumping speed	See Figure 3 and Figure 4
Peak pumping speed	
50 Hz electrical supply	25 m ³ h ⁻¹ (14.7 cfm)
60 Hz electrical supply	30 m ³ h ⁻¹ (17.6 cfm)

Table 2 - Performance data

2.3 Mechanical data

Dimensions	See Figure 2
Mass	
1-phase pump	44 kg
3-phase pump	38 kg
Inlet connection	NW40
Outlet connection	NW25
Gas-ballast inlet connection	1/8 inch BSP

Table 3 - Mechanical data

2.4 Gas-ballast supply (optional)

Maximum gas supply pressure	0.5 bar gauge, 1.5×10^5 Pa
Nominal gas flow rate	10 slm

Table 4 - Gas-ballast supply data

2.5 Noise and vibration data

Noise level (at 1 m from the pump, measured in an anechoic room)	
1-phase pump	< 62 dB(A)
3-phase pump	< 60 dB(A)
Vibration velocity (at the inlet flange)	< 1.5 mm s ⁻¹

Table 5 - Noise and vibration data

GVSP30 Scroll Pump

2.6 Electrical data

Electrical supply	See Table 7 and Table 8
Full load current ratings	See Table 7 and Table 8

Table 6 - Electrical data: general

	Electrical supply voltage			
	100	115	200	230
Full load current rating: A				
50 Hz	8.5	-	4.3	3.9
60 Hz	10.0	8.6	4.8	4.0
Motor rotational speed: r min ⁻¹				
50 Hz	1430	-	1430	1450
60 Hz	1660	1720	1690	1730

Table 7 - Electrical data: 1-phase pumps

	Electrical supply voltage					
	200	208	230	380	415	460
Full load current rating: A						
50 Hz	2.7	-	-	1.57	1.63	-
60 Hz	2.8	2.6	2.5	-	-	1.47
Motor rotational speed: r min ⁻¹						
50 Hz	1460	-	-	1470	1470	-
60 Hz	1740	1740	1760	-	-	1770

Table 8 - Electrical data: 3-phase pumps

2.7 Materials exposed to vacuum

Materials exposed to vacuum	PTFE (polytetrafluoroethylene) impregnated aluminium, stainless steel, steel bearings, PFPE (perfluoropolyether) grease, fluoroelastomer seals.
-----------------------------	---

Table 9 - Materials exposed to vacuum

GVSP30 Scroll Pump

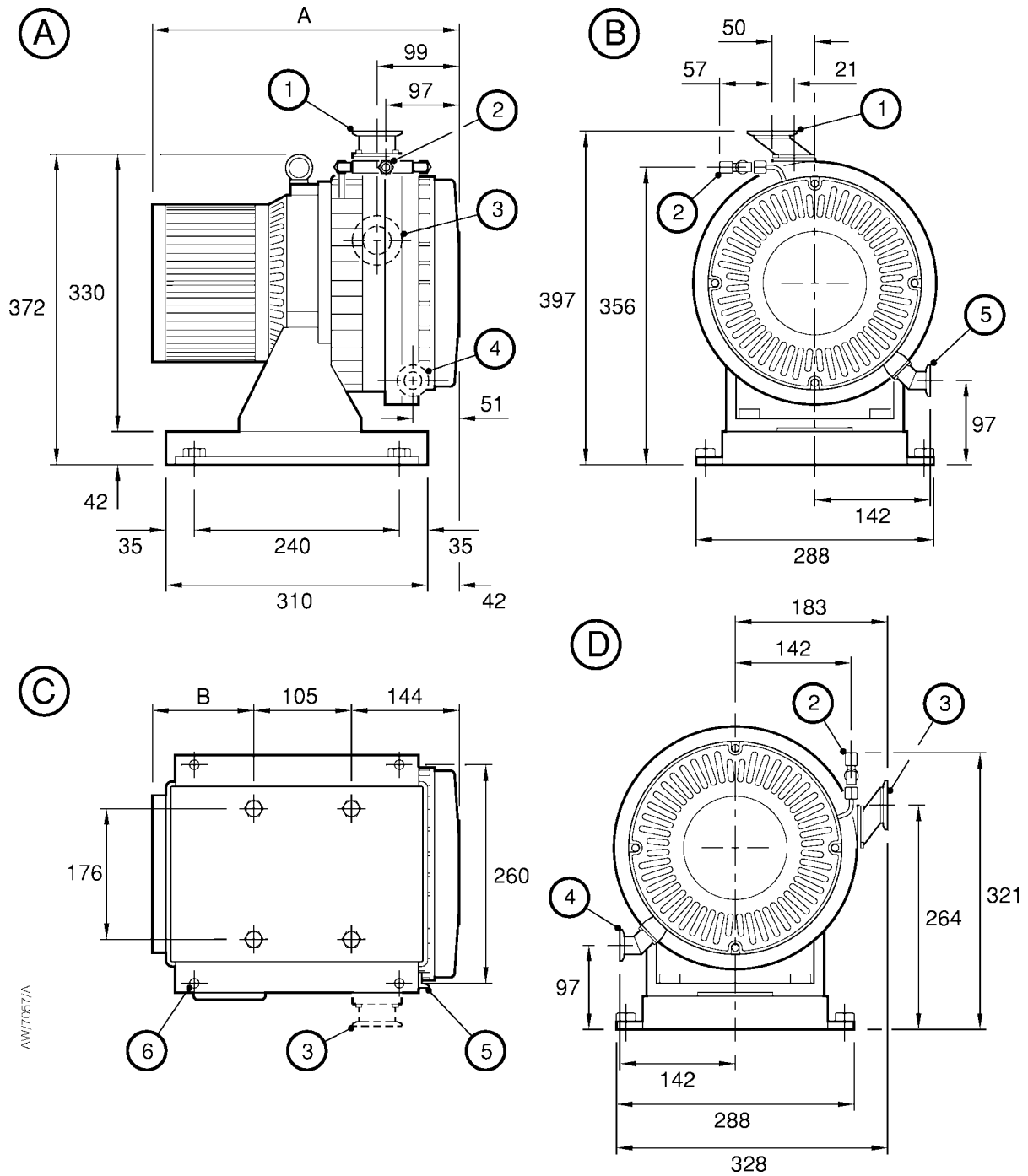

- A Side view
- B Front view (inlet/outlet as supplied)
- C Bottom view
- D Front view (alternative inlet/outlet positions)
- 1. Inlet-port
- 2. Gas-ballast inlet
- 3. Alternative inlet-port position
- 4. Alternative outlet-port position
- 5. Outlet-port
- 6. M8 mounting holes (4 off)

Pump	A	B
1-phase	443	194
3-phase	372	123

Figure 2 - Pump dimensions (mm): 3-phase pump shown

GVSP30 Scroll Pump

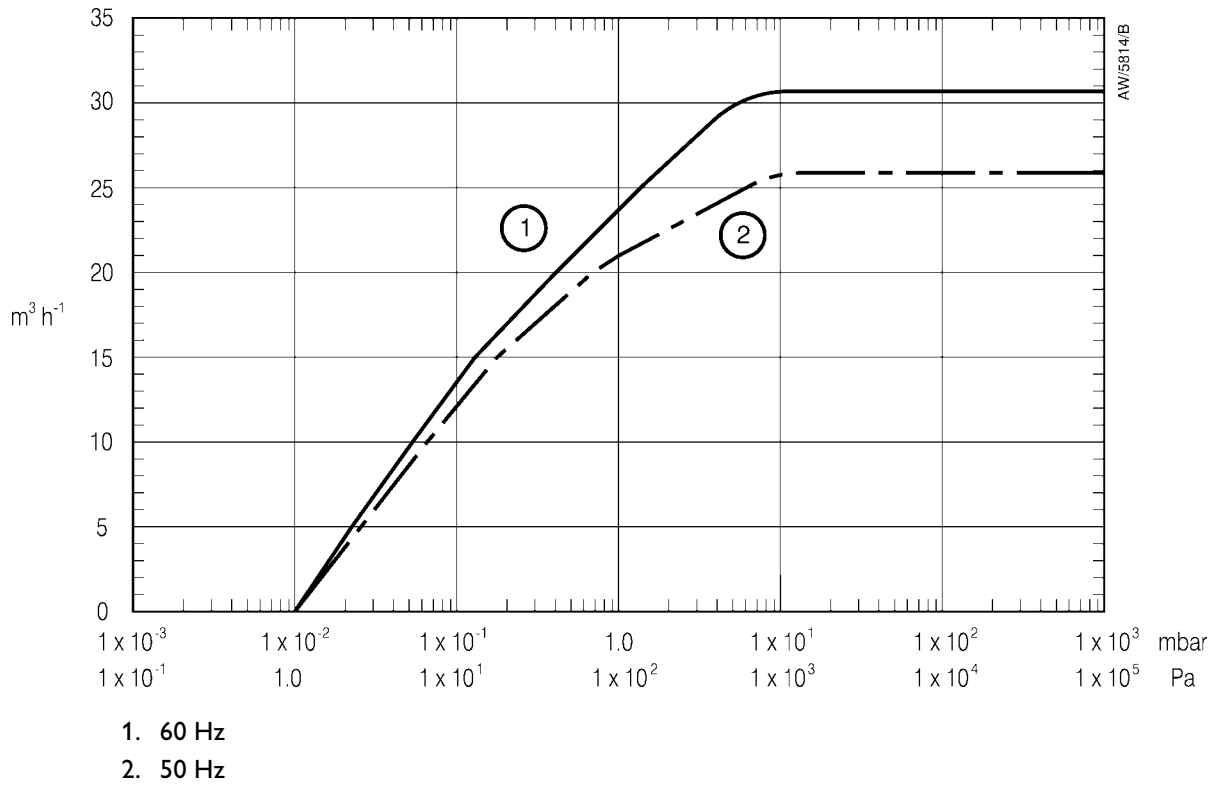

Figure 3 - Pumping speed/pressure graph ($m^3 h^{-1}$)

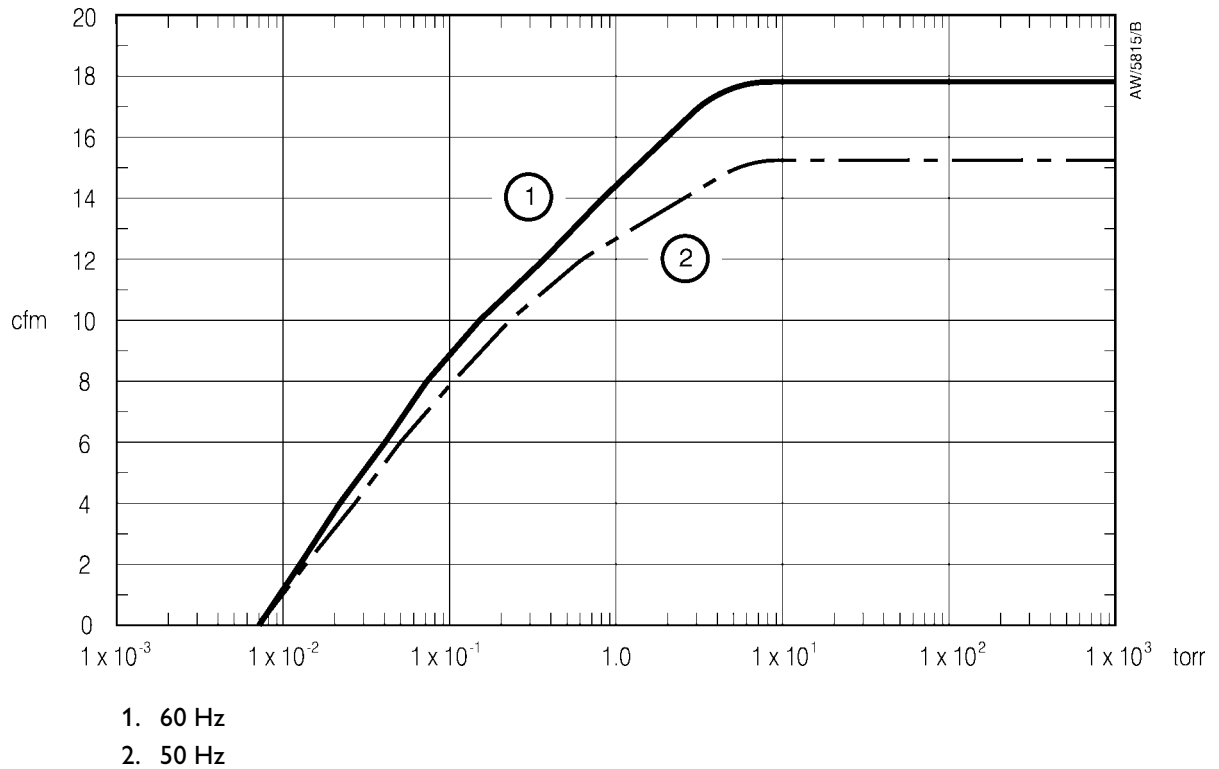



Figure 4 - Pumping speed/pressure graph (cfm)

3 INSTALLATION

3.1 Safety

	<p style="text-align: center; margin: 0;">WARNING</p> <p style="text-align: center; margin: 0;">Obey the safety instructions given below and take note of appropriate precautions. If you do not, you can cause injury to people and damage to equipment.</p>
---	--

- A suitably trained and supervised technician must install your GVSP30 pump.
- Ensure that the installation of the pump conforms with all the requirements of your local and national safety standards. Ensure that your control system is configured so that the pumping system is safe if the electrical supply fails.
- Ensure that the installation technician is familiar with the safety precautions for the gases processed by the pumping system. Wear the appropriate safety-clothing when you come into contact with contaminated components. Vent and purge the pumping system before you start installation work.
- Disconnect the other components in the pumping system from the electrical supply so that they cannot be operated accidentally.
- Do not reuse 'O' rings and Co-Seals if they are damaged.

3.2 System requirements

Consider the following points when you design your pumping system:

- Support the vacuum pipelines to stop the transmission of stress to the pipeline joints.
- You must be able to isolate the pump inlet and outlet from the atmosphere and from your vacuum system if you have pumped dangerous gases.

3.3 Unpack and inspect

1. Place the carton in a convenient position with a fork-lift truck or a pallet truck.
2. Remove all packing materials.
3. Use the lifting-handle (Figure 1, item 1) to lift the pump from its carton.
4. Remove all protective covers and inspect the pump. If the pump is damaged, notify your supplier and the carrier in writing within three days; state the Item Number of the pump together with your order number and your supplier's invoice number. Retain all packing materials for inspection. Do not use the pump if it is damaged.
5. If you want to connect an inert gas ballast supply to the GVSP30 (see Section 3.10), check that you have received a gas-ballast blanking cap with the pump; if the blanking cap is missing, notify your supplier in writing within three days.
6. If the pump is not to be used immediately, replace the protective covers. Store the pump in suitable conditions as described in Section 6.1.

3.4 Reconfigure the pump (optional)

Refer to Figure 2. The pump is supplied with the inlet flange at the top of the pump (as shown in detail B). If required, you can move the inlet flange to the side of the pump (as shown in detail D); refer to Figure 1 and use the following procedure:

1. Lift the pump into a vertical position so that it rests on the motor end-cover (11).
2. Undo and remove the four bolts which secure the fan cover (3) to the body of the pump. Remove the fan cover.
3. Undo and remove the five bolts (17) which secure the body of the pump to the motor.
4. Lift the body of the pump clear of the motor. If you cannot lift the body of the pump off of the motor, place two of the bolts removed in Step 3 in the jacking holes (16), then tighten the bolts to push the body of the pump away from the motor.
5. Turn the body of the pump through 90°, so that the inlet flange (2) is at the side of the pump.
6. Ensure that the flexible coupling and the two locating dowels (18) are correctly aligned, then lower the body of the pump back onto the motor shaft.
7. Turn the cooling-fan and check that the pump mechanism rotates smoothly. If you cannot turn the fan easily, the body of the pump is not correctly aligned on the motor.
8. Use the five bolts (17) removed in Step 3 to secure the body of the pump to the motor.
9. Use the four bolts removed in Step 2 to secure the fan cover (3) to the body of the pump.
10. Turn the pump over so that it rests on the base-plate (12).
11. Remove the four bolts (15) and remove the outlet flange (4) and 'O' ring seal from the pump body.

12. Turn the outlet flange through 180° (so that it is orientated as shown in Figure 2, item 4), ensure that the 'O' ring seal is correctly located, then refit the outlet flange (4) to the pump and secure with the four bolts (15).

3.5 Locate the pump

CAUTION

Locate the pump so that it is on a firm, level floor; the inclination of the floor must not exceed 5°. If you do not locate the pump correctly, seals in the pump may wear quickly and the performance of the pump will deteriorate.

Ensure that the pump is not installed in an enclosed area. The pump requires a cooling-air flow rate of 8 m³ min⁻¹. The cooling-fans will provide this flow rate if the pump is not installed in a restricted space.

Refer to Figure 1. Attach suitable lifting-gear to the lifting-eye (1) on the pump and move the pump to its final operating position. Note that:

- The pump can be free-standing; if required, adjust the bolts (13) to stabilise the pump.
- If required, you can remove the fixing-bolts (13) and fit other suitable bolts through the mounting-holes (Figure 2, items 6) in the base-plate of the pump to secure the pump to the floor.
- If required, you can fit vibration isolators below the base-plate. Suitable vibration isolators are available as optional accessories (see Section 7.4).

3.6 Connect the electrical supply

CAUTION

The motor is not thermally protected. You must provide external overload protection. Branch circuit fuses must have a maximum rating of 115% of the full load current rating given in Section 2.6.

3.6.1 Introduction

Connect the electrical supply to the motor as described in Section 3.6.2 or 3.6.3.

Connect the supply through a contactor which incorporates a circuit breaker suitable for the full load current ratings given in Tables 7 and 8.

3.6.2 Connect to 3-phase pumps

1. Remove the cover from the motor terminal-box (Figure 1, item 10).
2. Check your electrical supply voltage and frequency. The universal motor of the pump can be configured for 'low-voltage' operation (200-230 V) as shown in Figure 5, or for 'high-voltage' operation (380-460 V), as shown in Figure 6. If necessary, reconfigure the motor to operate with your supply voltage.
3. Fit a suitable 20 mm cable-gland to the cable leadthrough hole. If your cable is too large to pass through a 20 mm cable-gland, fit a 20 mm to 25 mm female thread adaptor to the cable entry-hole, and fit a 20 mm cable-gland to the adaptor.
4. Pass the electrical supply cable through the cable-gland.
5. Connect the phase wires in the cable (L1, L2, L3) to the U1, V1 and W1 terminals as shown in Figures 5 or 6, depending on your electrical supply voltage, then connect the earth (ground) wire in the cable to the earth (ground) stud in the terminal-box.
6. Tighten the cable-gland and refit the terminal-box cover.

7. Connect the wires at the other end of the cable to your electrical supply.

3.6.3 Connect to 1-phase pumps

1. Remove the cover from the motor terminal-box (Figure 1, item 10).
2. Check your electrical supply voltage and frequency. The universal motor of the pump can be configured for 'low-voltage' operation (100-115 V) as shown in Figure 7, or for 'high-voltage' operation (200-230 V), as shown in Figure 8. If necessary, reconfigure the motor to operate with your supply voltage.
3. Fit a suitable 20 mm cable-gland to the cable leadthrough hole. If your cable is too large to pass through a 20 mm cable-gland, fit a 20 mm to 25 mm female thread adaptor to the cable entry-hole, and fit a 20 mm cable-gland to the adaptor.
4. Pass the electrical supply cable through the cable-gland.
5. Connect the neutral and live wires in the cable (N, L) to the X and Z terminals as shown in Figures 7 or 8, depending on your electrical supply voltage, then connect the earth (ground) wire in the cable to the earth (ground) stud in the terminal-box.
6. Tighten the cable-gland and refit the terminal-box cover.
7. Connect the wires at the other end of the cable to your electrical supply.

GVSP30 Scroll Pump

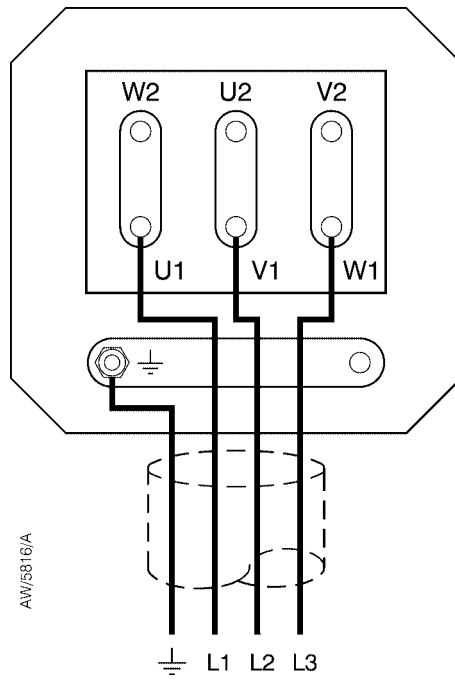

Figure 5 - Motor terminal-box low-voltage configuration: 3-phase pumps

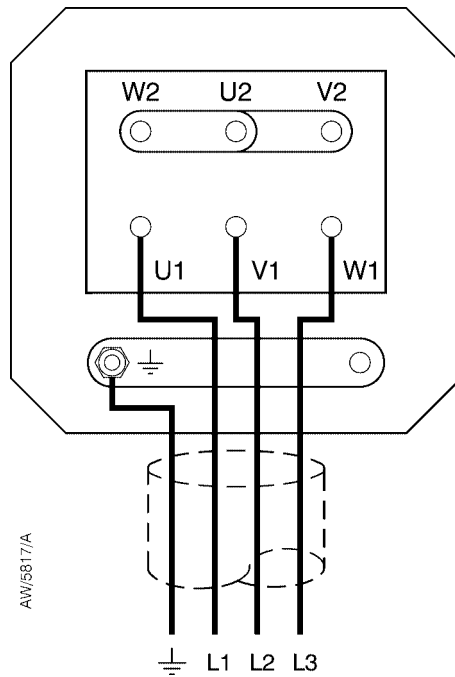

Figure 6 - Motor terminal-box high-voltage configuration: 3-phase pumps

GVSP30 Scroll Pump

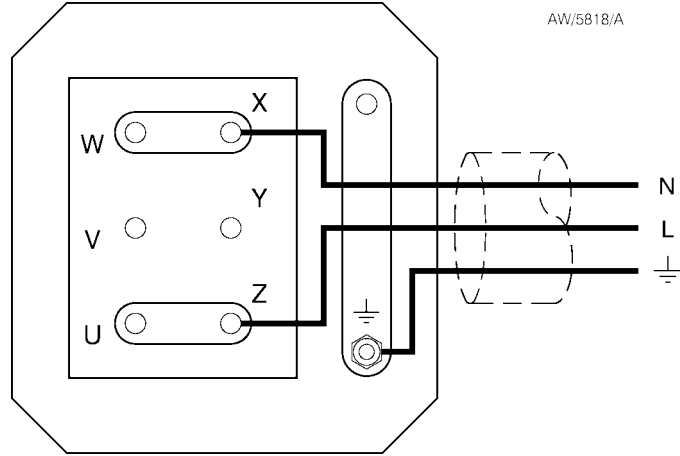

Figure 7 - Motor terminal-box low-voltage configuration: 1-phase pumps

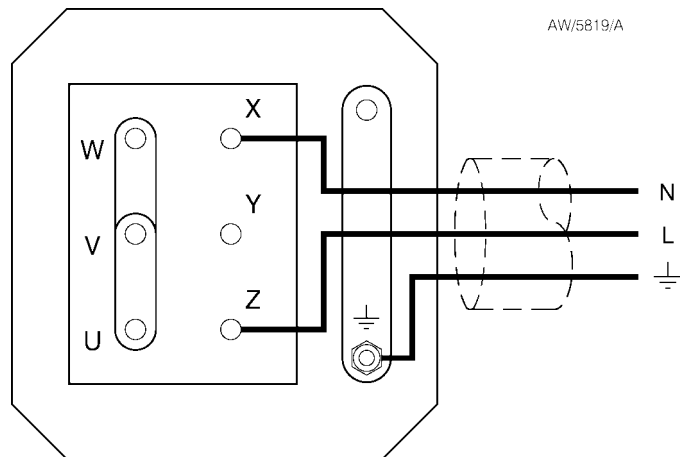

Figure 8 - Motor terminal-box high-voltage configuration: 1-phase pumps

3.7 Check the direction of motor rotation

CAUTION

Ensure that debris and objects do not fall into the pump inlet and outlet when you check the direction of motor rotation. If this happens, you may damage the pump.

Note: When you switch off the pump, the cooling-fan may stop and then rotate in the reverse direction for a few revolutions.

1. Watch the cooling-fan from the motor end of the pump, switch on the pump for two or three seconds, then switch the pump off.
2. The correct direction of rotation of the cooling-fan is clockwise when viewed from the motor end of the pump and is indicated by the arrow on the coupling cover (see Figure 1, item 7). If the direction of rotation is incorrect:
 - On a 3-phase pump, isolate the pump from the electrical supply, swap any two of the phase-wires in the motor terminal-box, then reconnect the pump to the electrical supply and repeat Step 1 to ensure that the direction of rotation is now correct.
 - On a 1-phase pump, do not use the pump; contact your supplier or BOC Edwards for advice.

3.8 Connect the pump inlet to the vacuum system

Ensure that debris does not get into the pump when you install it.

If the pump is to replace a pump in an existing system, purge the existing pump with nitrogen for 15 minutes before you disconnect it.

If the existing pump is an oil-sealed pump, we recommend that you dismantle the pipeline which connects the vacuum system to the pump and clean the pipeline to ensure that there is no residual oil contamination in the pipeline.

Use standard NW40 fittings to connect the pump-inlet to your vacuum system. When you connect to the vacuum system:

- To get the best pumping speed, ensure that the pipeline connected to the pump-inlet has an internal diameter not less than the inlet-port diameter, and is as short as possible.
- Incorporate flexible bellows in your system pipelines to reduce the transmission of vibration and to prevent loading of coupling-joints. The bellows must have a maximum pressure rating which is greater than the highest pressure that can be generated in your system. We recommend that you use BOC Edwards flexible bellows.
- Incorporate an inlet isolation-valve in the pipeline from the vacuum system to the pump, so that you can isolate the vacuum system from the pump when it is switched off and prevent the suck-back of process gases and debris into the vacuum system.

3.9 Connect the pump outlet

We recommend that you use an exhaust extraction-system suitable for use with all of the process gases you will pump. Note that:

- You must ensure that the exhaust-extraction system cannot become blocked or obstructed when the pump is operating.
- Ensure that you minimise (or if possible, eliminate) the use of 'U' bends, in which condensates may collect.

Use standard NW25 fittings to connect the pump-outlet to the exhaust-extraction system.

3.10 Configure the gas-ballast system (if necessary)

Refer to Figure 1, detail B. If you want to use gas-ballast on your application:

- As supplied, the gas-ballast system on the pump is closed, and has a blanking cap fitted to the gas-ballast inlet (9). The gas-ballast system incorporates a non-return valve, to prevent the leakage of pumped gas into the atmosphere.
- Alternatively, you can remove the blanking cap (8) and fit an inert gas supply pipeline to the gas-ballast inlet (9). Note that:
 - The gas supply must comply with the requirements of Section 2.4.
 - The gas supply pipeline must incorporate a flow control valve, to allow you to control the gas ballast flow rate into the pump.
 - Apply a suitable thread sealant (such as Loctite 242) to the threads of the gas-ballast inlet prior to connection of the pipeline, to ensure the leak tightness of the gas-ballast system.

If you require air gas-ballast on your application: remove the blanking cap and fit the filter (8) (supplied with the pump) to the gas-ballast inlet (9).

3.11 Leak test the pump installation

Leak test the pump installation and seal any leaks found to prevent the leakage of dangerous substances from the system and the leakage of air into the system.

When supplied, the leak tightness of the pump (with the gas-ballast inlet sealed) is less than 1×10^{-4} mbar l s⁻¹ (1×10^{-2} Pa l s⁻¹).

4 OPERATION

	<p>WARNING</p> <p>Do not use the GVSP30 to pump powders or explosive, flammable, corrosive or toxic substances. If you do, there may be a risk of explosion or fire.</p>
---	---

	<p>WARNING</p> <p>Never switch the inert gas-ballast supply on or off when the pump is operating. If you do, there may be a risk of injury, or the pump may fail.</p>
---	--

Note: The following procedures assume that your system has an inlet isolation-valve which you can use to isolate the pump from your vacuum system, and a means to open the pump-inlet to atmosphere.

4.1 Start-up

Use the procedure below to start up the pump.

1. Ensure that the vacuum system isolation-valve is closed.
2. If you have connected an inert gas supply to the gas-ballast inlet (see Section 3.10), switch on the inert gas supply and adjust the gas flow rate.
3. Switch on the electrical supply to the pump.
4. Open the vacuum system isolation-valve.

Note: If the pump fails to reach the specified ultimate pressure after a number of hours, either during initial start-up or after the pump has been shut down for a prolonged time, moisture in the pump may have affected its performance and you should use the following method to correct this: close the inlet isolation-valve and operate the pump for six to eight hours; briefly open the inlet to atmosphere two to three times per hour.

4.2 Shut-down

<p>CAUTION</p> <p>Close the vacuum system isolation-valve before you switch off the pump. If you do not, particulate in the pump may be sucked back into your vacuum system.</p>

<p>CAUTION</p> <p>If the pump will be left switched off for a long time, ensure that you purge the pump as described below. If you do not, particulate or moisture in the pump may damage it and cause it to fail when you next try to operate it.</p>

Note: When you switch off the pump, the cooling-fan may stop and then rotate in the reverse direction for a few revolutions.

Use the procedure below to shut down the pump.

1. Close the vacuum system isolation-valve (to prevent suck-back into the vacuum system).
2. If the pump will be left switched off for a long time:
 - Open the pump-inlet to atmosphere.
 - Leave the pump to operate for a few minutes, to purge the pump of particulate and moisture which may have collected in the pump.
3. Switch off the electrical supply to the pump.
4. If you have connected an inert gas supply to the gas-ballast inlet (see Section 3.10), switch off the inert gas supply.

5 MAINTENANCE

5.1 Safety information

	<p style="text-align: center;">WARNING</p> <p>Obey the safety instructions given below and take note of appropriate precautions. If you do not, you can cause injury to people and damage to equipment.</p>
---	--

- A suitably trained and supervised technician must maintain your GVSP30 pump.
- Ensure that the installation technician is familiar with the safety precautions for the gases pumped. Wear the appropriate safety-clothing when you come into contact with contaminated components. Vent and purge the pumping system before you start installation work.
- Purge the vacuum system and the pump with dry nitrogen if you will disconnect any of the vacuum or exhaust connections.
- Disconnect and isolate the other components in the pumping system from the electrical supply so that they cannot be operated accidentally.
- Take care to protect sealing-faces from damage.
- Do not reuse 'O' rings and Co-Seals if they are damaged.
- Dispose of components, debris and used cleaning solution safely: refer to Section 6.2.

- Do not touch or inhale the thermal breakdown products of fluorinated materials which may be present if the GVSP30 has been overheated to 260 °C and above. These breakdown products are very dangerous. Fluorinated materials in the GVSP30 include seals. The GVSP30 may have overheated if it was misused, if it malfunctioned, or if it was in a fire. BOC Edwards Material Safety Data Sheets for the fluorinated materials used in the GVSP30 are available on request: contact your supplier or BOC Edwards.
- Leak test the system after maintenance work is complete if you have disconnected any vacuum or exhaust joints; seal any leaks found.

5.2 Inspect the system

The GVSP30 pump is designed to require little user maintenance. Do the following checks when you maintain your vacuum system:

- Check that the vacuum connections are secure.
- If fitted, check that the inert gas supply pipeline is securely connected to the gas-ballast inlet, and that the connection does not leak.
- Check that the electrical connections are secure and that the electrical cable is not damaged.
- Check that the cooling-fins on the pump are not obstructed or blocked.
- If necessary, replace the gas-ballast filter.

5.3 Inspect the inlet screen

Whenever you disconnect the pump from your vacuum system, we recommend that you:

- Remove any debris trapped by the inlet screen (in the inlet-port).
- Inspect the inlet screen and if necessary, clean it with a cleaning solution suitable for the substances pumped.

To remove the inlet screen, remove the circlip which secures the inlet screen in the inlet-port.

After you have inspected/cleaned the inlet screen, refit the inlet screen in the inlet-port and secure with the circlip before you reconnect the pump to your vacuum system.

5.4 Service

We recommend that the GVSP30 pump is serviced by BOC Edwards service engineers every year (if the pump is in continuous use) or every 8500 hours of pump operation.

We recommend that the pump is given a minor service after the first year (or 8500 hours), followed by a major service after the next year (or 8500 hours), followed by a minor service, and so on.

Contact your supplier or BOC Edwards to arrange these services.

6 STORAGE AND DISPOSAL

6.1 Storage

Use the procedure below to store the pump.

1. Shut-down the pump as described in Section 4.2.
2. Isolate the pump from the electrical supply.
3. Purge the vacuum system and the GVSP30 pump with dry nitrogen.
4. Disconnect the GVSP30 pump from the vacuum system.
5. Place protective covers over the inlet and outlet-flanges.
6. Store the pump in cool, dry conditions until required for use. When required, prepare and install the pump as described in Section 3.

6.2 Disposal



WARNING

Do not incinerate the pump, or any of the 'O' rings or other seals. Seals in the pump (and other seals) are made from fluorinated materials. The thermal breakdown products of fluorinated materials are very dangerous (see Section 5.1).

Dispose of the pump and any components safely in accordance with all local and national safety and environmental requirements.

Take particular care with components which have been contaminated with dangerous process substances.

7 SERVICE, SPARES AND ACCESSORIES

7.1 Introduction

BOC Edwards products, spares and accessories are available from BOC Edwards companies in Belgium, Brazil, China, France, Germany, Israel, Italy, Japan, Korea, Singapore, United Kingdom, U.S.A and a world-wide network of distributors. The majority of these centres employ Service Engineers who have undergone comprehensive BOC Edwards training courses.

Order spare parts and accessories from your nearest BOC Edwards company or distributor. When you order, state for each part required:

- Model and Item Number of your equipment
- Serial number
- Item Number and description of part.

Spare	Item Number
Minor Service Kit *	A710-04-820
Major Service Kit	A710-04-800
Crank Pin Kit (1 only)	A710-03-006
Crank Pin Kit (set of 3)	A710-04-006
Motor Assembly: 1-phase	A710-04-010
Motor Assembly: 3-phase	A710-04-011
Tip Seals Kit *	A710-04-026
Pump Module	A710-04-030
Outlet Flange	A710-03-019
Inlet Flange	A710-04-016
Fan Cover	A710-04-024

Table 10 - Spares Item Numbers

* These Kits are part of the Major Service Kit.

7.2 Service

BOC Edwards products are supported by a world-wide network of BOC Edwards Service Centres. Each Service Centre offers a wide range of options including: equipment decontamination; service exchange; repair; rebuild and testing to factory specifications. Equipment which has been serviced, repaired or rebuilt is returned with a full warranty.

Your local Service Centre can also provide BOC Edwards engineers to support on-site maintenance, service or repair of your equipment.

For more information about service options, contact your nearest Service Centre or other BOC Edwards company.

7.3 Spares

Refer to Table 10 for the spares available for the ESDP12B pump.

7.4 Accessories

Fit vibration isolators to reduce vibration and noise when the ESDP12B pump is floor- or frame-mounted. The vibration isolators also help to reduce mechanical stresses when the pump is mounted on an uneven surface.

Refer to Table 11 for the Item Number of the vibration isolators.

Accessory	Item Number
Vibration isolators (pack of 4)	A248-01-404

Table 11 - Accessory Item Number

Return of BOC Edwards Equipment - Procedure

INTRODUCTION

Before returning your equipment, you must warn BOC Edwards if substances you used (and produced) in the equipment can be hazardous. This information is fundamental to the safety of our Service Centre employees and will determine the procedures employed to service your equipment.

Complete the Declaration (HS2) and send it to BOC Edwards before you dispatch the equipment. It is important to note that this declaration is for BOC Edwards internal use only, and has no relationship to local, national or international transportation safety or environmental requirements. As the person offering the equipment for shipment, it is your responsibility to ensure compliance with applicable laws.

GUIDELINES

- Equipment is '**uncontaminated**' if it has not been used, or if it has only been used with substances that are not hazardous. Your equipment is '**contaminated**' if it has been used with any substances classified as hazardous under EU Directive 67/548/EEC (as amended) or OSHA Occupational Safety (29 CFR 1910).
- If your equipment has been used with radioactive substances, biological or infectious agents, mercury, polychlorinated biphenyls (PCB's), dioxins or sodium azide, you must decontaminate it before you return it to BOC Edwards. You must send independent proof of decontamination (for example a certificate of analysis) to BOC Edwards with the Declaration (HS2). Phone BOC Edwards for advice.
- If your equipment is contaminated, you must either:
 - Remove all traces of contamination (to the satisfaction of laws governing the transportation of dangerous/hazardous substances).
 - Or, properly classify the hazard, mark, manifest and ship the equipment in accordance with applicable laws governing the shipment of hazardous materials.

Note: Some contaminated equipment may not be suitable for airfreight.

PROCEDURE

1. Contact BOC Edwards and obtain a Return Authorisation Number for your equipment.
2. Complete the Return of BOC Edwards Equipment - Declaration (HS2).
3. If the equipment is contaminated, you must contact your transporter to ensure that you properly classify the hazard, mark, manifest and ship the equipment, in accordance with applicable laws governing the shipment of contaminated/hazardous materials. As the person offering the equipment for shipment, it is your responsibility to ensure compliance with applicable law. **Note: Equipment contaminated with some hazardous materials, such as semiconductor by-products, may not be suitable for airfreight - contact your transporter for advice.**
4. Remove all traces of hazardous gases: pass an inert gas through the equipment and any accessories that will be returned to BOC Edwards. Where possible, drain all fluids and lubricants from the equipment and its accessories.
5. Seal up all of the equipment's inlets and outlets (including those where accessories were attached) with blanking flanges or, for uncontaminated product, with heavy gauge tape.
6. Seal equipment in a thick polythene/polyethylene bag or sheet.
7. If the equipment is large, strap the equipment and its accessories to a wooden pallet. If the equipment is too small to be strapped to a pallet, pack it in a suitable strong box.
8. Fax or post a copy of the Declaration (HS2) to BOC Edwards. The Declaration must arrive before the equipment.
9. Give a copy of the Declaration (HS2) to the transporter. You must tell your transporter if the equipment is contaminated.
10. Seal the original Declaration in a suitable envelope: attach the envelope securely to the outside of the equipment package, in a clear weatherproof bag.

WRITE YOUR RETURN AUTHORISATION NUMBER CLEARLY ON THE OUTSIDE OF THE ENVELOPE OR ON THE OUTSIDE OF THE EQUIPMENT PACKAGE.

Return of BOC Edwards Equipment - Declaration

Return Authorisation Number:

You must:

- Know about all of the substances which have been used and produced in the equipment before you complete this Declaration
- Read the Return of BOC Edwards Equipment - Procedure (HS1) before you complete this Declaration
- Contact BOC Edwards to obtain a Return Authorisation Number and to obtain advice if you have any questions
- Send this form to BOC Edwards before you return your equipment

SECTION 1: EQUIPMENT

Equipment/System Name _____

Part Number _____

Serial Number _____

Has the equipment been used, tested or operated ?

 YES Go to Section 2 NO Go to Section 4

IF APPLICABLE:

Tool Reference Number _____

Process _____

Failure Date _____

Serial Number of Replacement Equipment _____

SECTION 2: SUBSTANCES IN CONTACT WITH THE EQUIPMENT
Are any substances used or produced in the equipment:

- Radioactive, biological or infectious agents, mercury, poly chlorinated biphenyls (PCBs), dioxins or sodium azide? (if YES, see Note 1) YES NO
- Hazardous to human health and safety? YES NO

Note 1 : BOC Edwards will not accept delivery of any equipment that is contaminated with radioactive substances, biological/infectious agents, mercury, PCB's, dioxins or sodium azide, unless you:

- Decontaminate the equipment
- Provide proof of decontamination

YOU MUST CONTACT BOC EDWARDS FOR ADVICE BEFORE YOU RETURN SUCH EQUIPMENT

SECTION 3: LIST OF SUBSTANCES IN CONTACT WITH THE EQUIPMENT

Substance name	Chemical Symbol	Precautions required (for example, use protective gloves, etc.)	Action required after a spill, leak or exposure

SECTION 4: RETURN INFORMATION

Reason for return and symptoms of malfunction _____

- If you have a warranty claim:
- who did you buy the equipment from ? _____
 - give the supplier's invoice number _____

SECTION 5: DECLARATION

Print your name: _____ Print your job title: _____

Print your organisation: _____

Print your address: _____

Telephone number: _____ Date of equipment delivery: _____

I have made reasonable enquiry and I have supplied accurate information in this Declaration. I have not withheld any information, and I have followed the Return of BOC Edwards Equipment - Procedure (HS1).

Note: Please print out this form, sign it and return the signed form as hard copy.

Signed: _____ Date _____

This page intentionally blank.

UNITED KINGDOM**CORPORATE HEADQUARTERS****BOC EDWARDS**

Manor Royal
Crawley
West Sussex
RH10 9LW
Tel +(44) 1293 528844
Fax +(44) 1293 533453

BOC EDWARDS

Wingates Industrial Estate
Great Bank Road
Westhoughton, Bolton
Lancashire
BL5 3SL
Tel +(44) 1942 652652
Fax +(44) 1942 652651

AMERICA (USA)**USA HEADQUARTERS****BOC EDWARDS**

One Edwards Park
301 Ballardvale Street
Wilmington, MA 01887
Tel +(1) 978 658 5410
Toll free (USA only) 1 800 848 9800
Fax +(1) 978 658 7969

3901 Burton Drive
Santa Clara, CA 95054
Tel +(1) 408 496 1177
Fax +(1) 408 496 1188

1810 West Drake Drive
Suite 101
Tempe, AZ 85283
Tel +(1) 602 777 7007
Fax +(1) 602 777 2244

11701 Stonehollow Drive
Suite 100
Austin, TX 78758
Tel +(1) 512 491 6622
Fax +(1) 512 491 0629

3501 Island Avenue
Philadelphia, PA 19153
Tel +(1) 215 365 8653
Fax +(1) 978 753 6846

BELGIUM**BOC EDWARDS**

Bergensesteenweg 709
B1600 Sint-Pieters-Leeuw
Brussels
Tel +(32) 2 363 0030
Fax +(32) 2 363 0064

BRAZIL**BOC DO BRASIL LTDA
DIVISÃO EDWARDS ALTO VACO**

Rua Bernardo Wrona 222
02710 São Paulo-SP
Tel +(55) 11 3952 5000
Fax +(55) 11 3965 2766

CANADA**BOC EDWARDS**

5975 Falbourne Street
Mississauga, Ontario L5R3W6
Canada
Tel +(1) 905 501 2558
Fax +(1) 905 501 1632

12055 Cote de Liesse
Dorval, Quebec H9P1B4
Canada
Tel +(1) 514 631 3501
Fax +(1) 514 631 3502

CHINA**BOC TRADING
(SHANGHAI) CO. LTD.**

23 Fu Te Road (N)
Wai Gao Qiao Free Trade Zone
Pudong
Shanghai, 200131
PRC China
Tel +(86 21) 5866 9618
Fax +(86 21) 5866 9993

FRANCE**BOC EDWARDS**

125 Avenue Louis Roche
92238 Gennevilliers, Cedex
Paris
Tel +(33) 1 47 98 24 01
Fax +(33) 1 47 98 44 54

GERMANY**BOC EDWARDS**

Ammerthalstraße 36
85551 Kirchheim
Munich
Tel +(49) 89 99 19 18 0
Fax +(49) 89 99 19 18 99

HONG KONG S.A.R.**BOC EDWARDS (ASIA)**

12 Chun Yat Street
Tseung Kwan O Industrial Estate
Tseung Kwan O, Kowloon
Hong Kong S.A.R.
Tel +(852) 2372 2640
Fax +(852) 2796 9095

INDIA**BOC EDWARDS**

DIVIN. OF BOC INDIA LIMITED
203 Surya Kiran Building
19 Kasturba Gandhi Marg
New Delhi - 110 001
India
Tel +(91) 11 851 0065
Fax +(91) 11 851 0245

ISRAEL**EDWARDS ISRAEL VACUUM LTD.**

5 Habarzel Blvd
Gat 2000 Industrial Zone
Qiryat Gat 82000
Tel +(972) 8 681 0633
Fax +(972) 8 681 0640

ITALY**BOC EDWARDS**

Via Carpaccio 35
20090 Trezzano sul Naviglio
Milan
Tel +(39) 02 48 4471
Fax +(39) 02 48 401638

JAPAN**HEADQUARTERS****BOC EDWARDS**

Shuwa Shiba Park Building A-3F
2-4-1 Shibakoen Minato-ku
Tokyo, 105-0011
Tel +(81) (0) 3 5470 6530
Fax +(81) (0) 3 5470 6521

KOREA**HEADQUARTERS****SONGWON EDWARDS LTD.**

5th FL. Daewoo Engineering Bldg.
Soonae-dong
Bundang-gu, Sungnam City
Kyungki-do, Korea
Tel +(82) 31 716 7070
Fax +(82) 31 738 1001-3

FACTORY & GV**SONGWON EDWARDS LTD.**

625-7 Upsong-dong
Chunan City
Chungchong Nam-do
Korea
Tel +(82) 41 621 7070
Fax +(82) 41 621 7700

SINGAPORE**BOC EDWARDS (ASIA)**

42 Loyang Drive
Loyang Industrial Estate
Singapore 508962
Tel +(65) 6546 8408
Fax +(65) 6546 8407

TAIWAN, R.O.C.**EDWARDS TECHNOLOGIES
LIMITED**

No. 434 Chung hua Road
Toufen Town, Miaoli County
Taiwan ROC
Tel +(886) 37 611422
Fax +(886) 37 611401

PLEASE CONTACT ANY OF THESE COMPANIES FOR DETAILS OF OTHER SALES AND SERVICE CENTRES IN YOUR AREA.

BOC Edwards is part of BOC Limited. BOC Edwards and the stripe symbol are trade marks of The BOC Group.

© BOC Edwards 2003

Produced by Technical Publicity Techpublicity@edwards.boc.com

<http://www.bocedwards.com>
info@bocedwards.com

 **BOC EDWARDS**