

400 Series Mass Storage Devices

Illustrated Parts Breakdown

Order Number: EK-441AE-IP. F01

Digital Equipment Corporation
Maynard, Massachusetts

Digital Equipment Corporation reserves the right, without notice, to make substitutions and modifications in the specifications of products documented in this manual and further reserves the right to withdraw any of these products from the market without notice.

Digital Equipment Corporation is not responsible for errors which may appear in the technical description (including illustrations and photographs) of the products covered by this manual.

None of the descriptions contained in this manual imply the granting of any license whatsoever to make, use or sell equipment constructed in accordance therewith.

Restricted Rights: Use, duplication or disclosure by the U.S. Government is subject to restrictions as set forth in subparagraph (c) (1) (ii) of the Rights in Technical Data and Computer Software clause at DFARS 252.227-2713.

Copyright © 1990, 1991, 1992, 1993, 1995 by Digital Equipment Corporation. All rights reserved.
Printed in U.S.A.

The postage-paid READER'S COMMENTS form on the last page of this document requests your critical evaluation to assist us in preparing future documentation.

The following are trademarks of Digital Equipment Corporation :

DECdirect, EF, RF, RZ, RRD, TF, TK, TZ, TLZ, DLTZ and the DIGITAL logo.

**ILLUSTRATED
PARTS
BREAKDOWN**

**400 SERIES
MASS STORAGE DEVICES**

ILLUSTRATED PARTS BREAKDOWN (IPB)

The IPB is used to identify a part and its location in a hardware product. The document references specific item numbers in the associated parts list.

HOW TO USE THE IPB

1. Locate the figure containing the item of interest.
2. Locate the number (callout) of the item of interest.
3. Locate that item number in the associated parts list.

FORMAT

Each IPB is generally organized based on its first figure. All other assemblies and subassemblies are referenced from this figure. Each figure contains numeric callouts of all major parts (items).

PARTS LIST

Each parts list contains the following:

Figure and Item No. – Lists the figure number and its referenced numeric callout

Description – Presents the name and a brief description of the item. A single asterisk (*) preceding the description denotes item is a

subassembly to its referenced figure. A double asterisk (**) preceding the description indicates that this item is subordinate to the preceding single asterisk item.

Digital Part No. – Lists the Digital/Vendor part number. The letter in the column heading indicates the current revision level of the Engineering Drawing for the referenced figure.

ECO Cut-In – Lists the top assembly drawing number and revision level at first printing. All additional revisions to an item are listed in this column.

Used On Code – Lists letters referring to the product variation assigned in Figure 1. When this column is blank, the item is used in all variations.

Ref Fig No. – Lists a cross reference between figures within the IPB.

PART NUMBER/PART DESCRIPTION INDEX SECTION

Lists items by part number numerically, and description alphabetically. Items are also referenced to a location within the IPB by figure and item number.

		REVISION HISTORY		RELATED IPBs	
PRINTING	ECO LEVEL	ECO LEVEL (Continued)			
15-FEB-95 6th Printing	RF31E	0000-00002	RZ73E	00006-00006	SYSTEM LEVEL: EK-438AB-IP EK-439AA-IP ENCLOSURE LEVEL: EK-440AB-IP DOCUMENTATION KIT (EK-4000S-DK) INCLUDES: EK-438AB-IP EK-439AA-IP EK-440AB-IP EK-441AE-IP
	RF31F	00000-00000	RZ74E	00000-00000	
	70-28086	00000-00004	RZ28E	00000-00000	
	RF31T	00000-00000	RZ282	00000-00000	
	RF312	00000-00000	70-22863	00000-00000	
	70-29475	00000-00002	RZ26L	00000-00000	
	RF35E	00000-00000	RZ262	00000-00000	
	RF36E	00000-00000	RRD43	00000-00000	
	RF352	00000-00000	70-22864	00000-00000	
	RF362	00000-00000	TLZ04	00000-00002	
	70-29457	00000-00002	70-28090	00000-00001	
	RF71E	00000-00001	TLZ07	00001-00002	
	RF72E	00001-00001	DLTLZ07	00001-00001	
	RF73E	00000-00000	70-22866	00000-00000	
	RF74E	00000-00000	TZ86	00000-00000	
	70-28087	00000-00005	TZ87	00000-00000	
	EF51R	00002-00002	70-22865	00001-00001	
	EF52R	00002-00002	70-28081	00000-00001	
	EF53	00000-00000	70-29547	00000-00000	
	TF85E	00000-00000	TK50E	00000-00000	
	TF86E	00000-00000	70-22839	00000-00001	
	70-28092	00000-00004	TK70E	00000-00001	
	70-27049	00000-00001	70-28088	00000-00001	
	70-29478	00001-00001			
	70-27050	00000-00001			
	RZ56E	00001-00002			
	RZ57E	00001-00002			
	RZ58E	00000-00000			
	70-28089	00000-00001			

THIS PAGE INTENTIONALLY LEFT BLANK

DSSI DRIVES

☞ INDICATES FRU LEVEL PARTS.

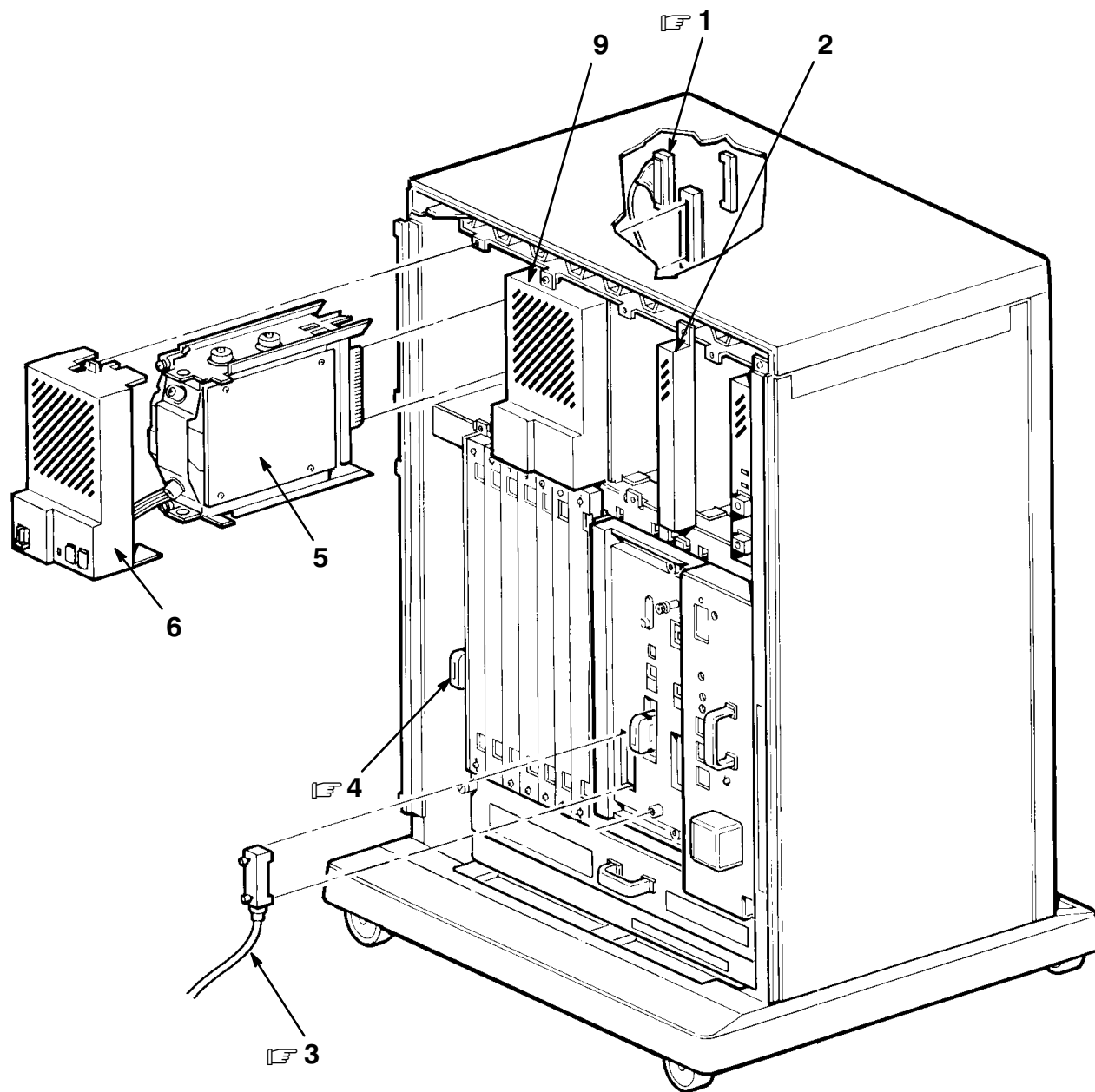

400ST-01-SC

Figure 1. Typical RF DSSI System Mounting and Cabling (Sheet 1 of 2)

INDICATES FRU LEVEL PARTS.

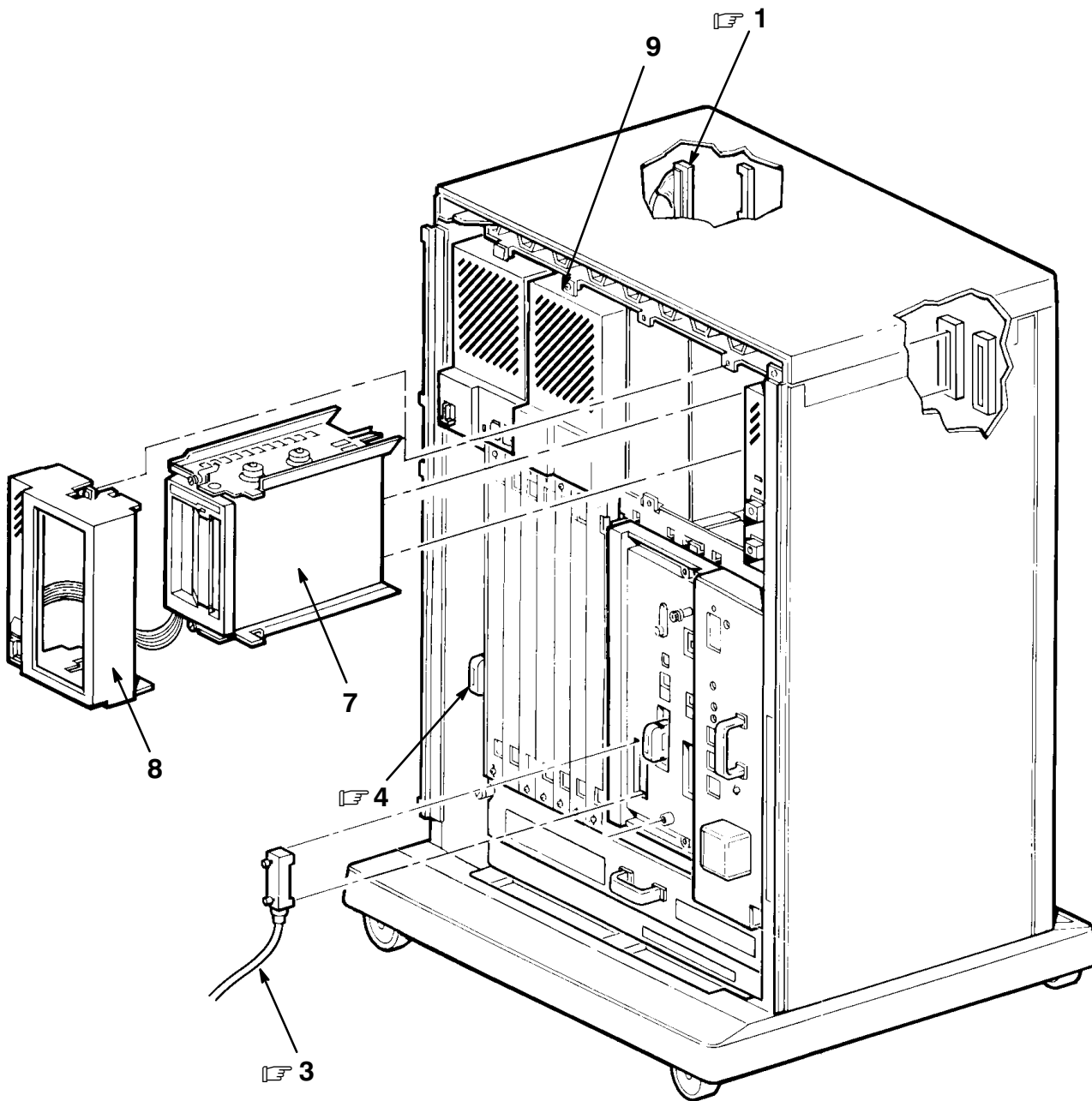

400ST-01A-SC

Figure 1. Typical TF DSSI System Mounting and Cabling (Sheet 2 of 2)

FIG. & ITEM NO.	DESCRIPTION	DIGITAL PART NO.	ECO CUT-IN	USED ON CODE	REF FIG NO.
1-	TYPICAL DSSI SYSTEM MOUNTING and CABLING				
1	*Cable Assembly, Internal DSSI	70-27458-01			
2	*Bezel Assembly, Filler	70-27414-01			
3	*Cable Assembly, 50 Cond Molded Micro-D (BC21M-09)	17-02152-03			
4	*Connector, Terminator	12-29258-01			
5	*RF31E DISK DRIVE ASSEMBLY	RF31E-AA			2
	*RF31E DISK DRIVE ASSEMBLY	RF31E-AF			2
	*RF31F DISK DRIVE ASSEMBLY	RF31F-AA			3
	*RF31F DISK DRIVE ASSEMBLY	RF31F-AF			3
	*RF31T DISK DRIVE ASSEMBLY	RF31T-AA			5
	*RF31T DISK DRIVE ASSEMBLY	RF31T-AF			5
	*RF312 DISK DRIVE ASSEMBLY	RF312-AA			6
	*RF312 DISK DRIVE ASSEMBLY	RF312-AF			6
	*RF35E DISK DRIVE ASSEMBLY	RF35E-AA			8
	*RF35E DISK DRIVE ASSEMBLY	RF35E-AF			8
	*RF352 DISK DRIVE ASSEMBLY	RF352-AA			9
	*RF352 DISK DRIVE ASSEMBLY	RF352-AF			9
	*RF36E DISK DRIVE ASSEMBLY	RF36E-AA			11
	*RF36E DISK DRIVE ASSEMBLY	RF36E-AF			11
	*RF362 DISK DRIVE ASSEMBLY	RF362-AA			12
	*RF362 DISK DRIVE ASSEMBLY	RF362-AF			12
	*RF71E DISK DRIVE ASSEMBLY	RF71E-AA			14
	*RF71E DISK DRIVE ASSEMBLY	RF71E-AF			14
	*RF72E DISK DRIVE ASSEMBLY	RF72E-AA			15
	*RF72E DISK DRIVE ASSEMBLY	RF72E-AF			15
	*RF73E DISK DRIVE ASSEMBLY	RF73E-AA			16
	*RF73E DISK DRIVE ASSEMBLY	RF73E-AF			16
	*RF74E DISK DRIVE ASSEMBLY	RF74E-AA			17
	*RF74E DISK DRIVE ASSEMBLY	RF74E-AF			17
	*EF51R DISK DRIVE ASSEMBLY	EF51R-AA			19
	*EF51R DISK DRIVE ASSEMBLY	EF51R-AF			19
	*EF52R DISK DRIVE ASSEMBLY	EF52R-AA			20
	*EF52R DISK DRIVE ASSEMBLY	EF52R-AF			20
	*EF53 DISK DRIVE ASSEMBLY	EF53-AA			21
	*EF53 DISK DRIVE ASSEMBLY	EF53-AF			21
6	*BEZEL ASSEMBLY, 5 1/4 INCH DSSI DISK DRIVE	70-27049-04			27
	*BEZEL ASSEMBLY, 3 1/2 INCH DSSI DISK DRIVE	70-29478-02			28
7	*TF85E TAPE DRIVE ASSEMBLY	TF85E-JA			23
	*TF85E TAPE DRIVE ASSEMBLY	TF85E-JF			23
	*TF86E TAPE DRIVE ASSEMBLY	TF86E-JA			25
	*TF86E TAPE DRIVE ASSEMBLY	TF86E-JF			25
8	*BEZEL ASSEMBLY, TAPE DRIVE	70-27050-03			29
9	*BEZEL ASSEMBLY, BLANK	70-27049-01			30

THIS PAGE INTENTIONALLY LEFT BLANK

INDICATES FRU LEVEL PARTS.

PARTS LIST

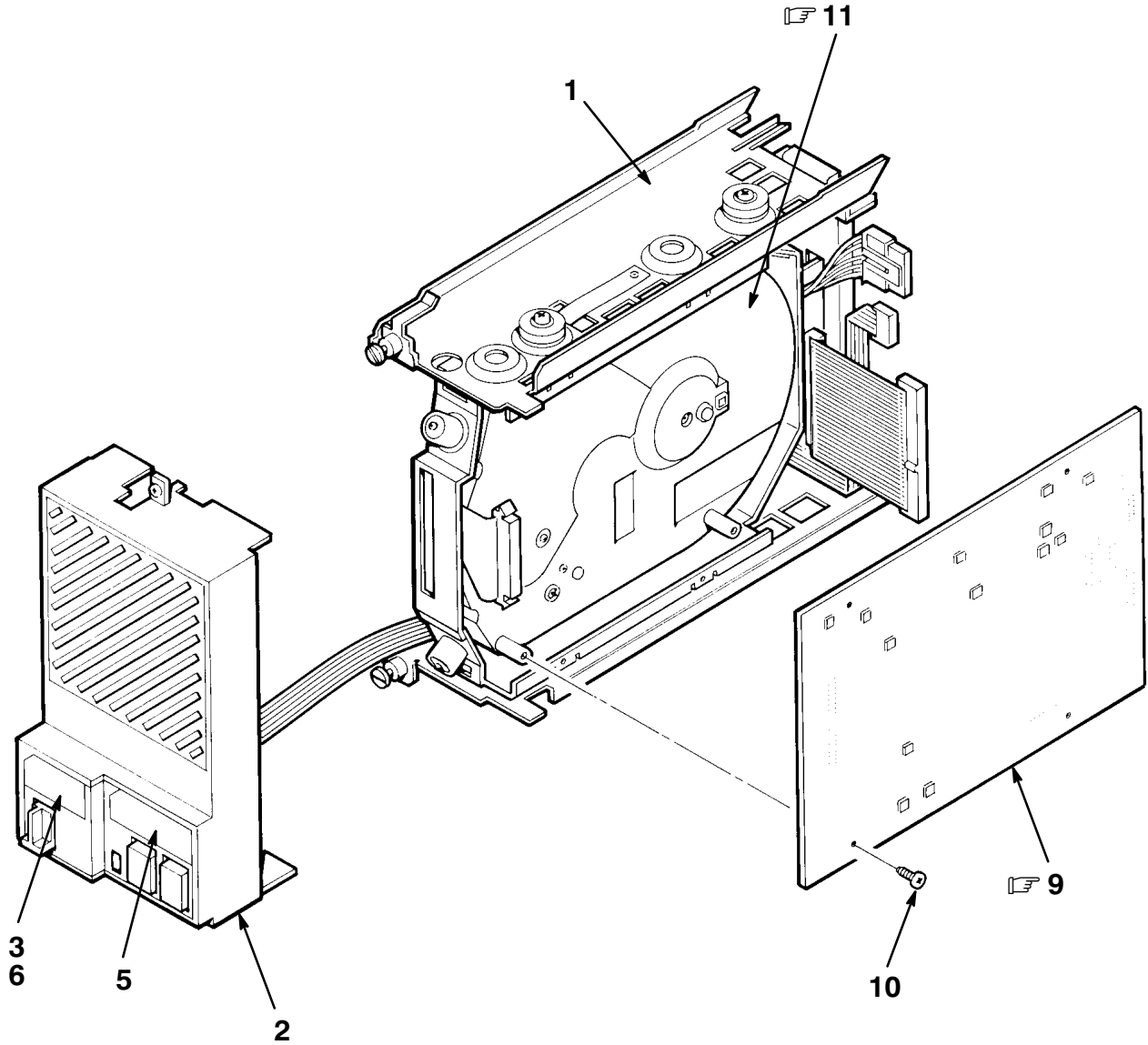

400ST-02-SC

Figure 2. Storage Element, RF31E

FIG. & ITEM NO.	DESCRIPTION	DIGITAL PART NO. ^c	ECO CUT-IN RF31E 00000	USED ON CODE	REF FIG NO.
2-	STORAGE ELEMENT, RF31E Code A – Used on RF31E-AA Code B – Used on RF31E-AF	RF31E-AA RF31E-AF		A B	
1	*MOUNTING ASSEMBLY, RF31E ISE	70-28086-01			4
2	*BEZEL ASSEMBLY, 5 1/4 INCH DSSI DISK DRIVE	70-27049-04			1,27
3	*Label, Switch Marker	36-18940-02			
4	*Label, "Bar Code" (Not Shown) (deleted)	36-33151-03	00002		
5	*Label, "Drive No. 2 Language Variant" See Note 1	36-33183-02			
6	*Label, "No. 2 Language Variant" (See Note 1)	36-33183-04			
7	*Documentation, "Storage Device Add On Procedure" (Not Shown)	EK-BA44A-IN		B	
8	*Package Assembly (Not Shown)	37-01215-04		B	
9	Module, RF31 Drive (See Note 2)	54-18329-01			
10	Screw, Machine Phi Pan Hd No. 4-40 x 3/8 (See Note 2)	90-06011-01			
11	Mechanics Assembly, RF31 (See Note 2)	70-24697-01			
	Note 1: Language Specific Used In Place Of 01, 03.				
	Note 2: Not Part of RF31E-AA/AF Assembly, Shown For Reference Only.				

INDICATES FRU LEVEL PARTS.

PARTS LIST

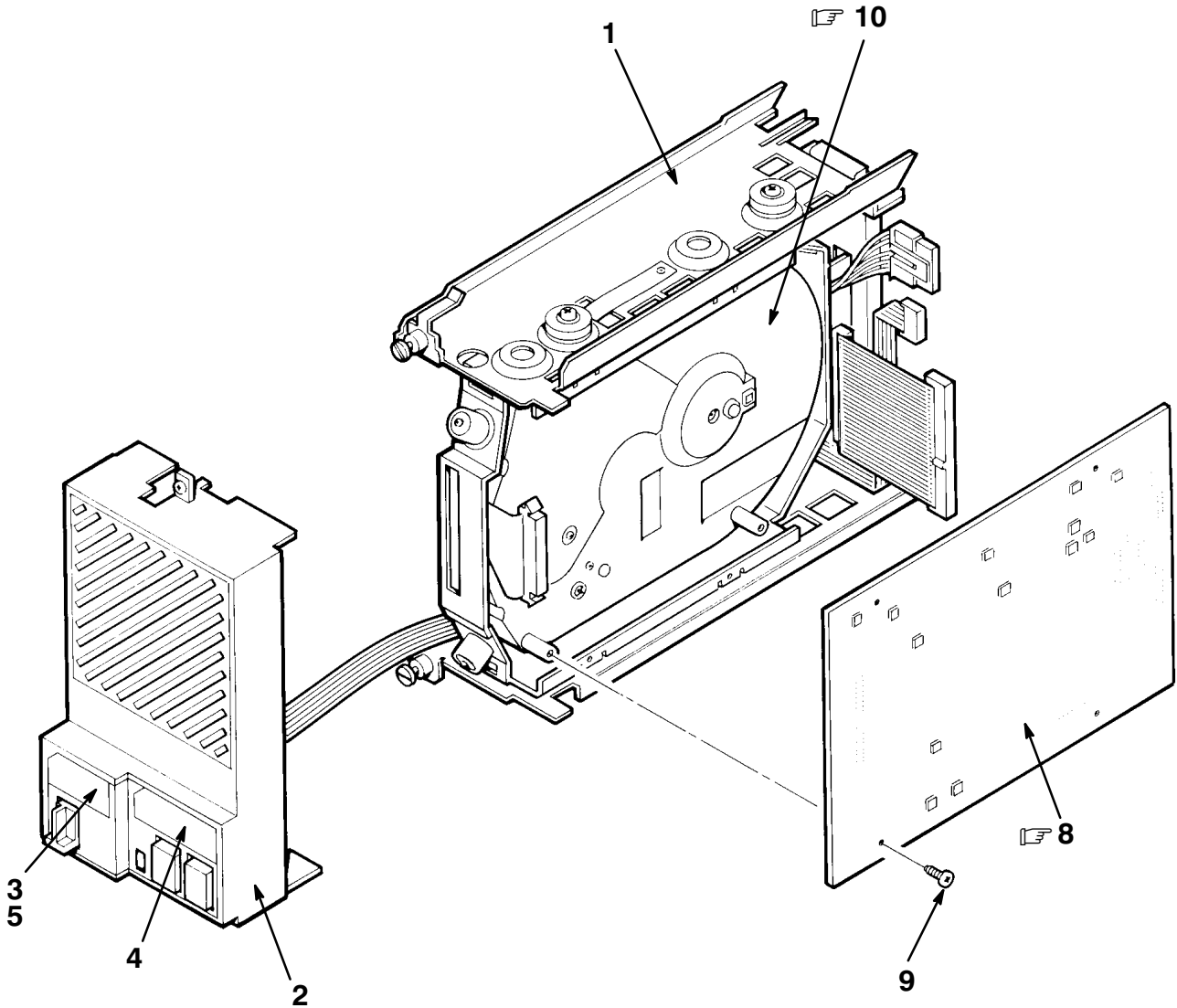

400ST-03-SC

Figure 3. Storage Element, RF31F

FIG. & ITEM NO.	DESCRIPTION	DIGITAL PART NO. ^A	ECO CUT-IN RF31F 00000	USED ON CODE	REF FIG NO.
3-	STORAGE ELEMENT, RF31F				1
	Code A – Used on RF31F-AA	RF31F-AA		A	
	Code B – Used on RF31F-AF	RF31F-AF		B	
1	*MOUNTING ASSEMBLY, RF31F ISE	70-28086-02			4
2	*BEZEL ASSEMBLY, 5 1/4 INCH DSSI DISK DRIVE	70-27049-04			1,27
3	*Label, Switch Marker	36-18940-02			
4	*Label, "Drive No. 2 Language Variant" See Note 1	36-33183-02			
5	*Label, "No. 2 Language Variant" (See Note 1)	36-33183-04			
6	*Documentation, "Storage Device Add On Procedure" (Not Shown)	EK-BA44A-IN		B	
7	*Package Assembly (Not Shown)	37-01215-04		B	
8	Module, RF31F Drive (See Note 2)	54-18329-02			
9	Screw, Machine Phi Pan Hd No. 4-40 x 3/8 (See Note 2)	90-06011-01			
10	Mechanics Assembly, RF31F (See Note 2)	70-24697-01			
	Note 1: Language Specific Used In Place Of 01, 03.				
	Note 2: Not Part of RF31F-AA/AF Assembly, Shown For Reference Only.				

 INDICATES FRU LEVEL PARTS.

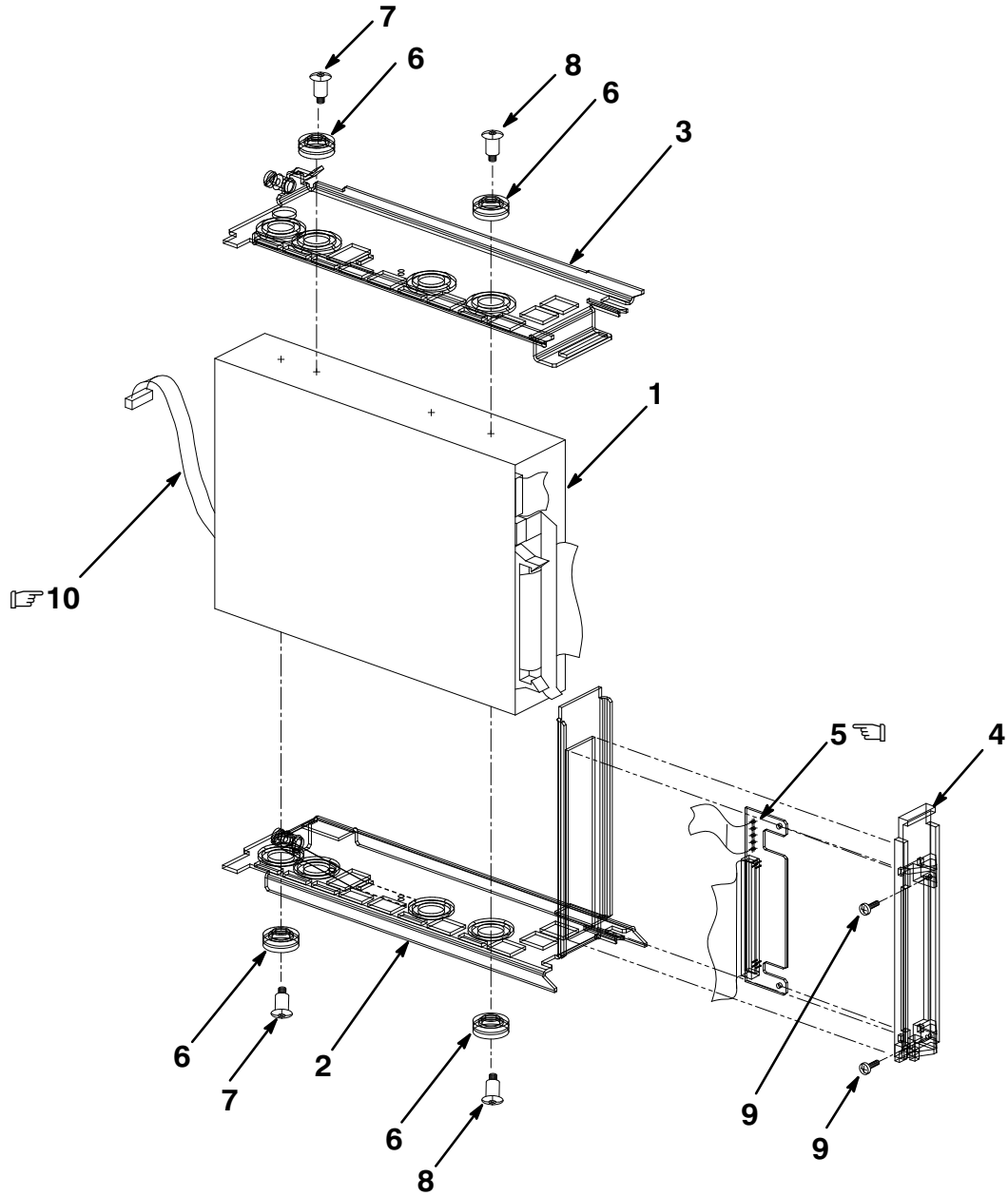

400ST-04-IL

Figure 4. Mounting Assembly, RF31E/RF31F ISE

FIG. & ITEM NO.	DESCRIPTION	D DIGITAL PART NO.	ECO CUT-IN 70-28086 00000	USED ON CODE	REF FIG NO.
4-	MOUNTING ASSEMBLY, RF31E ISE	70-28086-01		A	2
	MOUNTING ASSEMBLY, RF31F ISE	70-28086-02	00002	B	3
☞1	*Disk Drive Assembly RF31E	RF31-EA		A	
	*Disk Drive Assembly RF31F	RF31F-EA	00002	B	
2	*Bracket Assembly, Bottom Drive	70-27469-01			
3	*Bracket Assembly, Top Drive	74-40846-01			
4	*Bracket, Paddle Board	74-38830-01			
☞5	*Module, DSSI Interface Card	54-19787-01			
6	*Isolator, Shock (deleted)	12-32626-01	00001		
	*Isolator, Shock Grommet (added)	12-32626-04	00001		
7	*Screw, Machine Phi Pan Hd No. 6-32 x 1/2 (deleted)	90-06024-02	00001		
	*Screw, Shoulder No. 6-32 x 1/2 (added)	12-34462-01	00001		
8	*Screw, Machine Flat Hd No. 6-32 x 5/8 (deleted)	90-06025-02	00001		
	*Screw, Shoulder No. 6-32 x 1/2 (added)	12-34462-01	00001		
9	*Screw, Phi Pan Hd No. 4-40 x 1/4	90-09315-01			
☞10	*Cable Assembly, 10 Cond	17-02706-01			

FIG. & ITEM NO.	DESCRIPTION	DIGITAL PART NO. ^A	ECO CUT-IN RF31T 00000	USED ON CODE	REF FIG NO.
5-	STORAGE ELEMENT, RF31T				1
	Code A – Used on RF31T-AA	RF31T-AA		A	
	Code B – Used on RF31T-AF	RF31T-AF		B	
1	*MOUNTING ASSEMBLY, RF31T ISE	70-29475-03			7
2	*BEZEL ASSEMBLY, 3 1/2 INCH DSSI DISK DRIVE	70-29478-02			1,28
3	*Documentation, "Storage Device Add On Procedure" (Not Shown)	EK-BA44A-IN		B	
4	*Package Assembly (Not Shown)	37-01215-01		B	

  INDICATES FRU LEVEL PARTS.

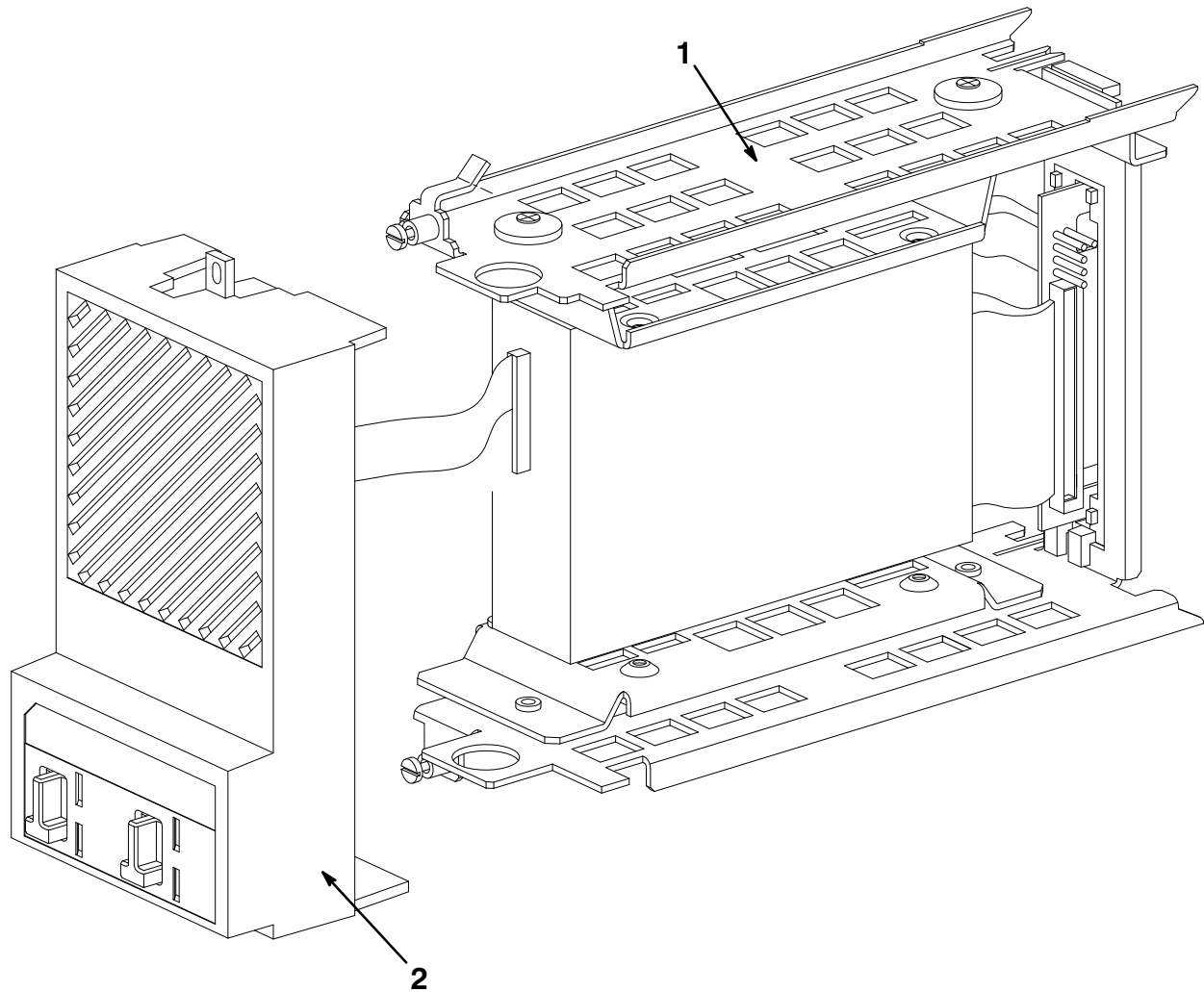

400ST-05-IL

Figure 5. Storage Element, RF31T

FIG. & ITEM NO.	DESCRIPTION	DIGITAL PART NO. ^A	ECO CUT-IN RF312 00000	USED ON CODE	REF FIG NO.
6-	STORAGE ELEMENT, RF312 DUAL				1
	Code A – Used on RF312-AA	RF312-AA		A	
	Code B – Used on RF312-AF	RF312-AF		B	
1	*MOUNTING ASSEMBLY, RF35 ISE DUAL	70-29475-04			7
2	*BEZEL ASSEMBLY, 3 1/2 INCH DSSI DISK DRIVE	70-29478-02			1,28
3	*Documentation, "Storage Device Add On Procedure" (Not Shown)	EK-BA44A-IN		B	
4	*Package Assembly (Not Shown)	37-01215-01		B	

  INDICATES FRU LEVEL PARTS.

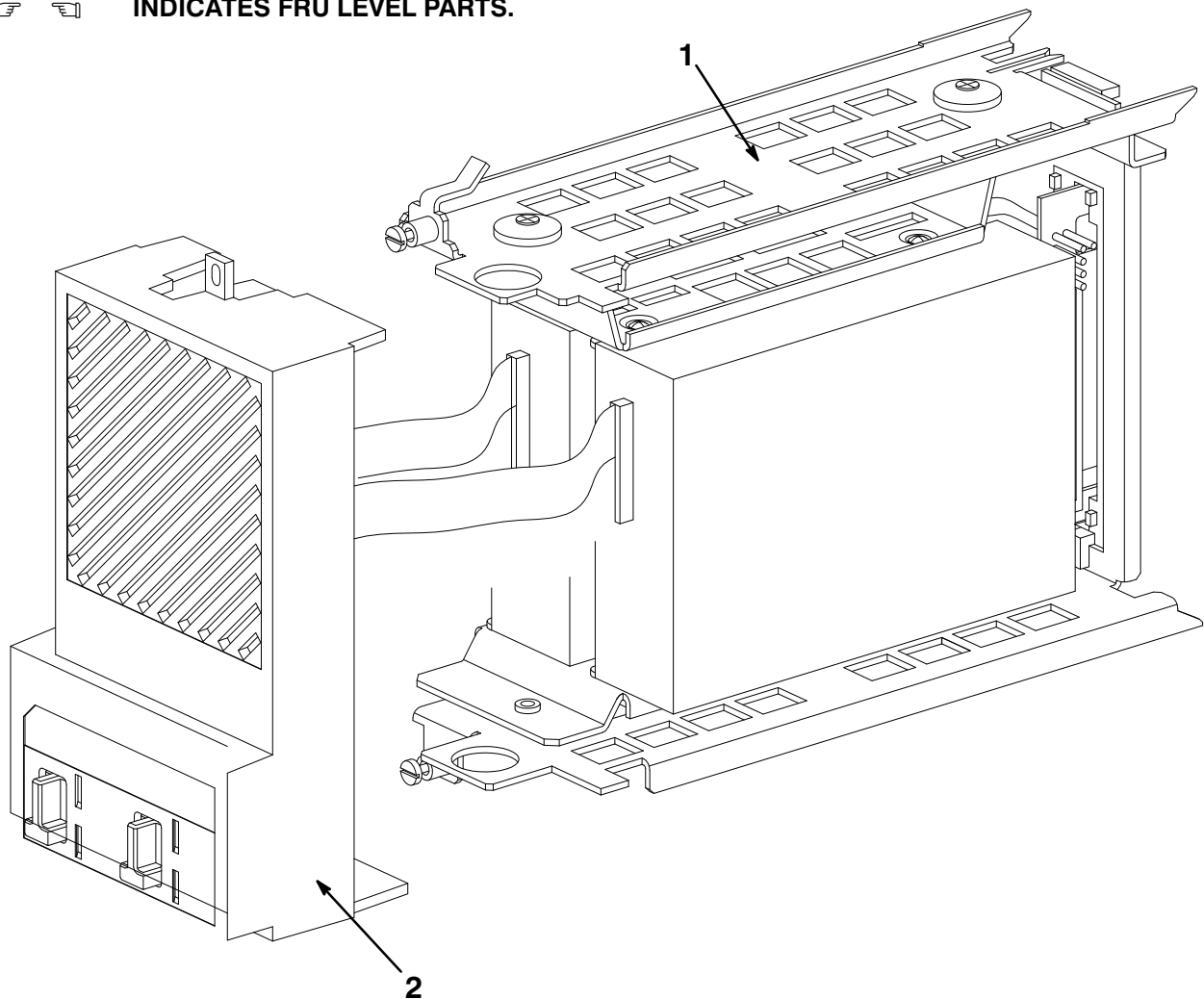

400ST-06-IL

Figure 6. Storage Element, RF312 DUAL

  INDICATES FRU LEVEL PARTS.

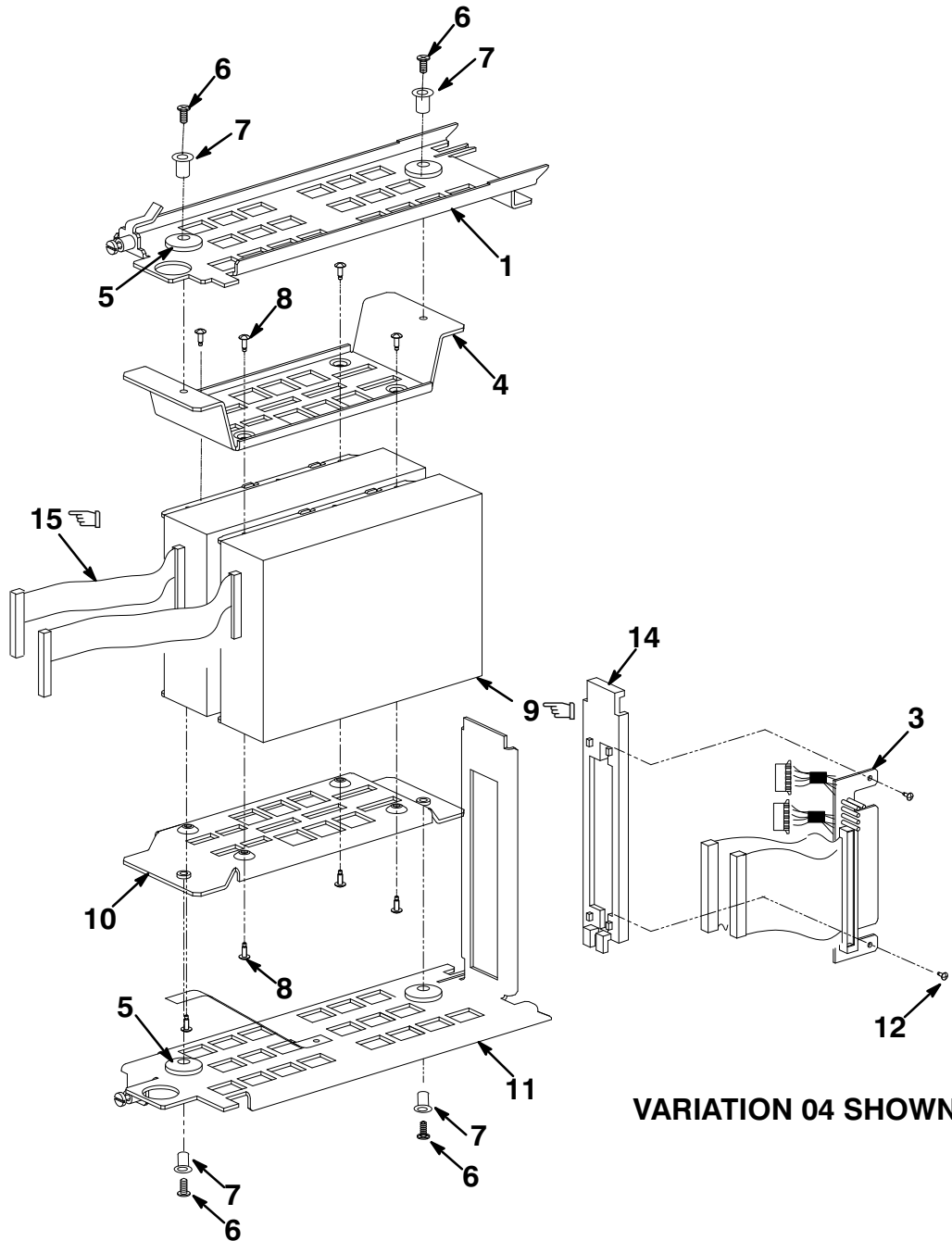

400ST-07-IL

Figure 7. Mounting Assembly, RF31T ISE

FIG. & ITEM NO.	DESCRIPTION	DIGITAL PART NO. ^c	ECO CUT-IN 70-29475 00000	USED ON CODE	REF FIG NO.
7-	MOUNTING ASSEMBLY, RF31T ISE MOUNTING ASSEMBLY, RF312 ISE DUAL	70-29475-03 70-29475-04		A B	5 6
1	*Bracket Assembly, Top Drive	74-44231-01			
2	This Item Is Not Used.				
3	*Module, Paddle	54-19787-03			
4	*Plate, Top Bracket Adapter	74-44233-01			
5	*Isolator, Shock Grommet	12-32626-04			
6	*Screw, Machine Flat Hd No. 6-32 x 5/8	90-06025-02			
7	*Isolator, Shock Ferrule	12-32626-03			
8	*Screw, Sems Phl Hd No. 6-32 x 1/4	90-10174-00			
9	*Storage Element, RF31T (See Note)	RF31T-EA			
10	*Plate, Bottom Bracket Adapter	74-44234-01			
11	*Bracket Assembly, Bottom Drive	70-29476-01			
12	*Screw, Phl Pan Hd No. 4-40 x 1/4	90-09315-01			
13	This Item Is Not Used.				
14	*Bracket, Paddle Module	74-38830-01			
15	*Cable Assembly, RFP 7 in. Female Flat (See Note)	17-03428-01			
	NOTE: Use Quantity of 1 for 70-29475-03. Use Quantity of 2 for 70-29475-04.				

FIG. & ITEM NO.	DESCRIPTION	DIGITAL PART NO. ^A	ECO CUT-IN RF35E 00000	USED ON CODE	REF FIG NO.
8-	STORAGE ELEMENT, RF35E				
	Code A – Used on RF35E-AA	RF35E-AA		A	
	Code B – Used on RF35E-AF	RF35E-AF		B	
1	*MOUNTING ASSEMBLY, RF35 ISE	70-29475-01			10
2	*BEZEL ASSEMBLY, 3 1/2 INCH DSSI DISK DRIVE	70-29478-02			1,28
3	*Documentation, "Storage Device Add On Procedure" (Not Shown)	EK-BA44A-IN		B	
4	*Package Assembly (Not Shown)	37-01215-01		B	

  INDICATES FRU LEVEL PARTS.

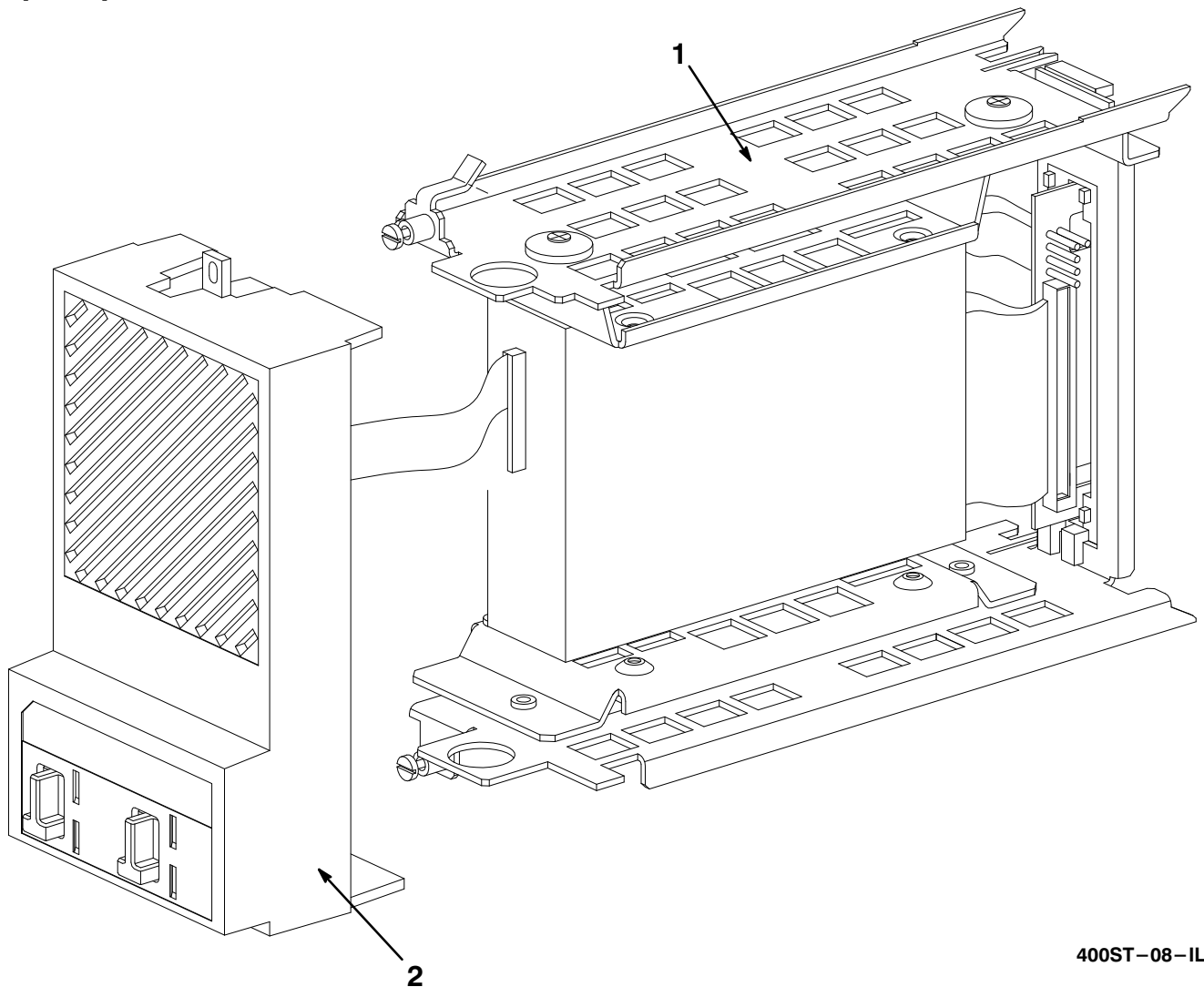

400ST-08-IL

Figure 8. Storage Element, RF35E

FIG. & ITEM NO.	DESCRIPTION	DIGITAL PART NO. ^A	ECO CUT-IN RF352 00000	USED ON CODE	REF FIG NO.
9-	STORAGE ELEMENT, RF352 DUAL				
	Code A – Used on RF352-AA	RF352-AA		A	
	Code B – Used on RF352-AF	RF352-AF		B	
1	*MOUNTING ASSEMBLY, RF35 ISE DUAL	70-29475-02			10
2	*BEZEL ASSEMBLY, 3 1/2 INCH DSSI DISK DRIVE	70-29478-02			1,28
3	*Documentation, "Storage Device Add On Procedure" (Not Shown)	EK-BA44A-IN		B	
4	*Package Assembly (Not Shown)	37-01215-01		B	

  INDICATES FRU LEVEL PARTS.

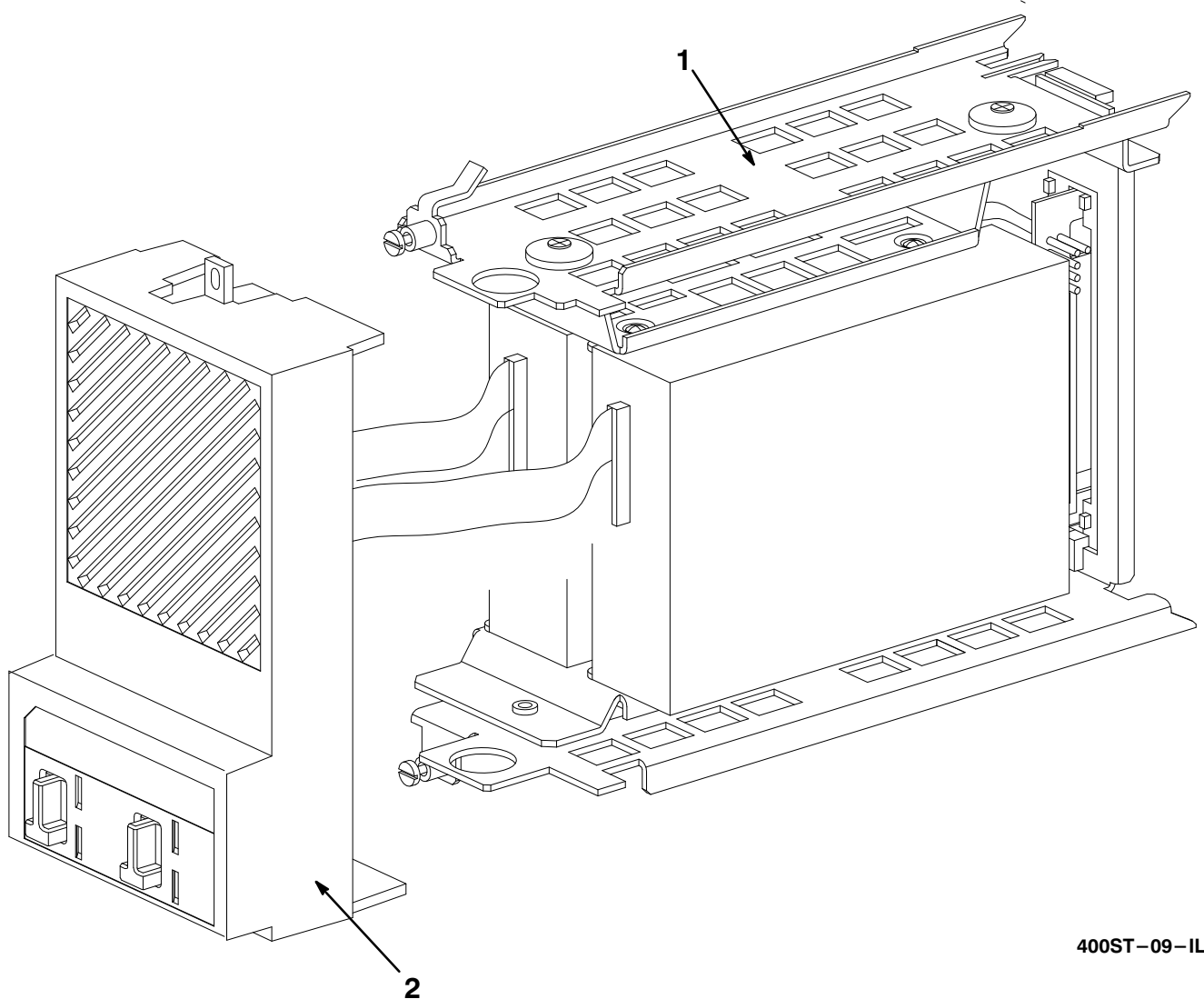

400ST-09-IL

Figure 9. Storage Element, RF352 Dual

INDICATES FRU LEVEL PARTS.

PARTS LIST

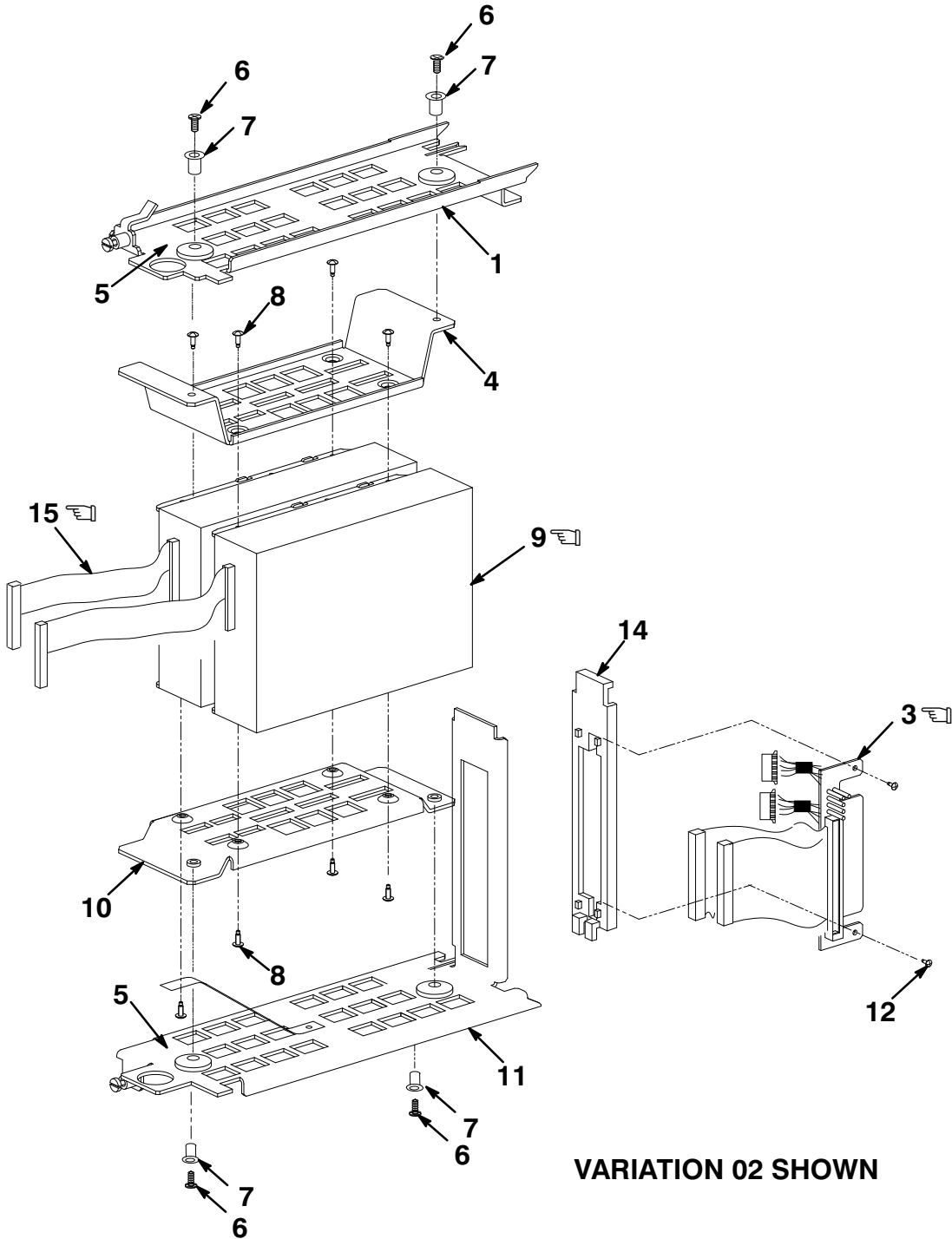

VARIATION 02 SHOWN

400ST-10-IL

Figure 10. Mounting Assembly, RF35 ISE

FIG. & ITEM NO.	DESCRIPTION	DIGITAL PART NO. ^c	ECO CUT-IN 70-29475 00000	USED ON CODE	REF FIG NO.
10-	MOUNTING ASSEMBLY, RF35 ISE MOUNTING ASSEMBLY, RF35 ISE DUAL	70-29475-01 70-29475-02		A B	8 9
1	*Bracket Assembly, Top Drive	74-44231-01			
2	This Item Is Not Used.				
☞3	*Module, Paddle	54-19787-03			
4	*Plate, Top Bracket Adapter	74-44233-01			
5	*Isolator, Shock Grommet	12-32626-04			
6	*Screw, Machine Flat Hd No. 6-32 x 5/8	90-06025-02			
7	*Isolator, Shock Ferrule	12-32626-03			
8	*Screw, Sems Phl Hd No. 6-32 x 1/4	90-10174-00			
☞9	*Storage Element, RF35E (See Note)	RF35-EA			
10	*Plate, Bottom Bracket Adapter	74-44234-01			
11	*Bracket Assembly, Bottom Drive	70-29476-01			
12	*Screw, Phl Pan Hd No. 4-40 x 1/4	90-09315-01			
13	This Item Is Not Used.				
14	*Bracket, Paddle Module	74-38830-01			
☞15	*Cable Assembly, RFP 7 in. Female Flat (See Note)	17-03428-01			
<p>NOTE: Use Quantity of 1 for 70-29475-01. Use Quantity of 2 for 70-29475-02.</p>					

FIG. & ITEM NO.	DESCRIPTION	DIGITAL PART NO. ^A	ECO CUT-IN RF36E 00000	USED ON CODE	REF FIG NO.
11-	STORAGE ELEMENT, RF36E				1
	Code A – Used on RF36E-AA	RF36E-AA		A	
	Code B – Used on RF36E-AF	RF36E-AF		B	
1	*MOUNTING ASSEMBLY, RF36 ISE	70-29475-05			13
2	*BEZEL ASSEMBLY, 3 1/2 INCH DSSI DISK DRIVE	70-29478-02			1,28
3	*Documentation, "Storage Device Add On Procedure" (Not Shown)	EK-BA44A-IN		B	
4	*Package Assembly (Not Shown)	37-01215-01		B	

  INDICATES FRU LEVEL PARTS.

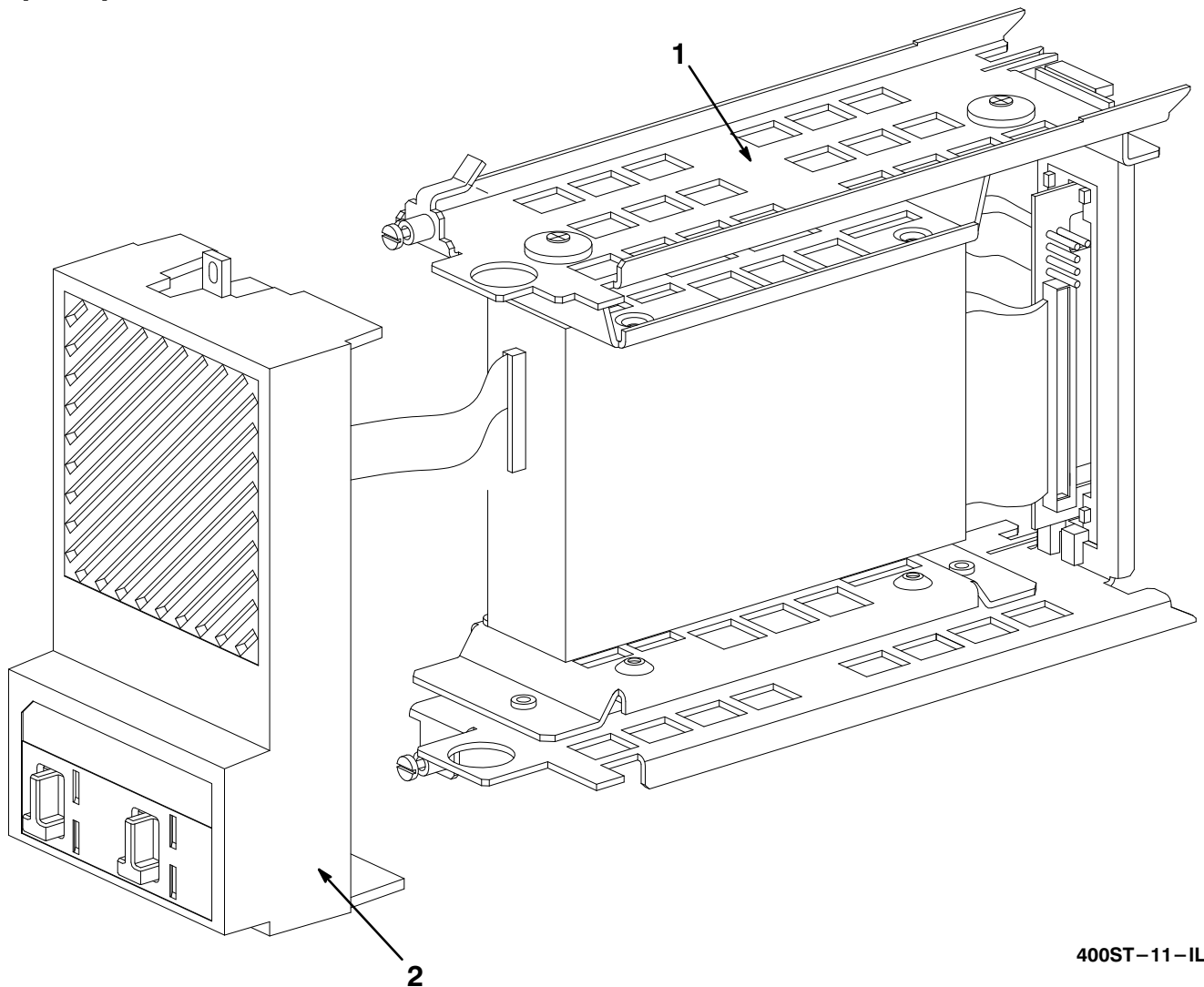

400ST-11-IL

Figure 11. Storage Element, RF36E

FIG. & ITEM NO.	DESCRIPTION	DIGITAL PART NO. ^A	ECO CUT-IN RF362 00000	USED ON CODE	REF FIG NO.
12-	STORAGE ELEMENT, RF362 DUAL				1
	Code A – Used on RF362-AA	RF362-AA		A	
	Code B – Used on RF362-AF	RF362-AF		B	
1	*MOUNTING ASSEMBLY, RF36 ISE DUAL	70-29475-06			13
2	*BEZEL ASSEMBLY, 3 1/2 INCH DSSI DISK DRIVE	70-29478-02			1,28
3	*Documentation, "Storage Device Add On Procedure" (Not Shown)	EK-BA44A-IN		B	
4	*Package Assembly (Not Shown)	37-01215-01		B	

  INDICATES FRU LEVEL PARTS.

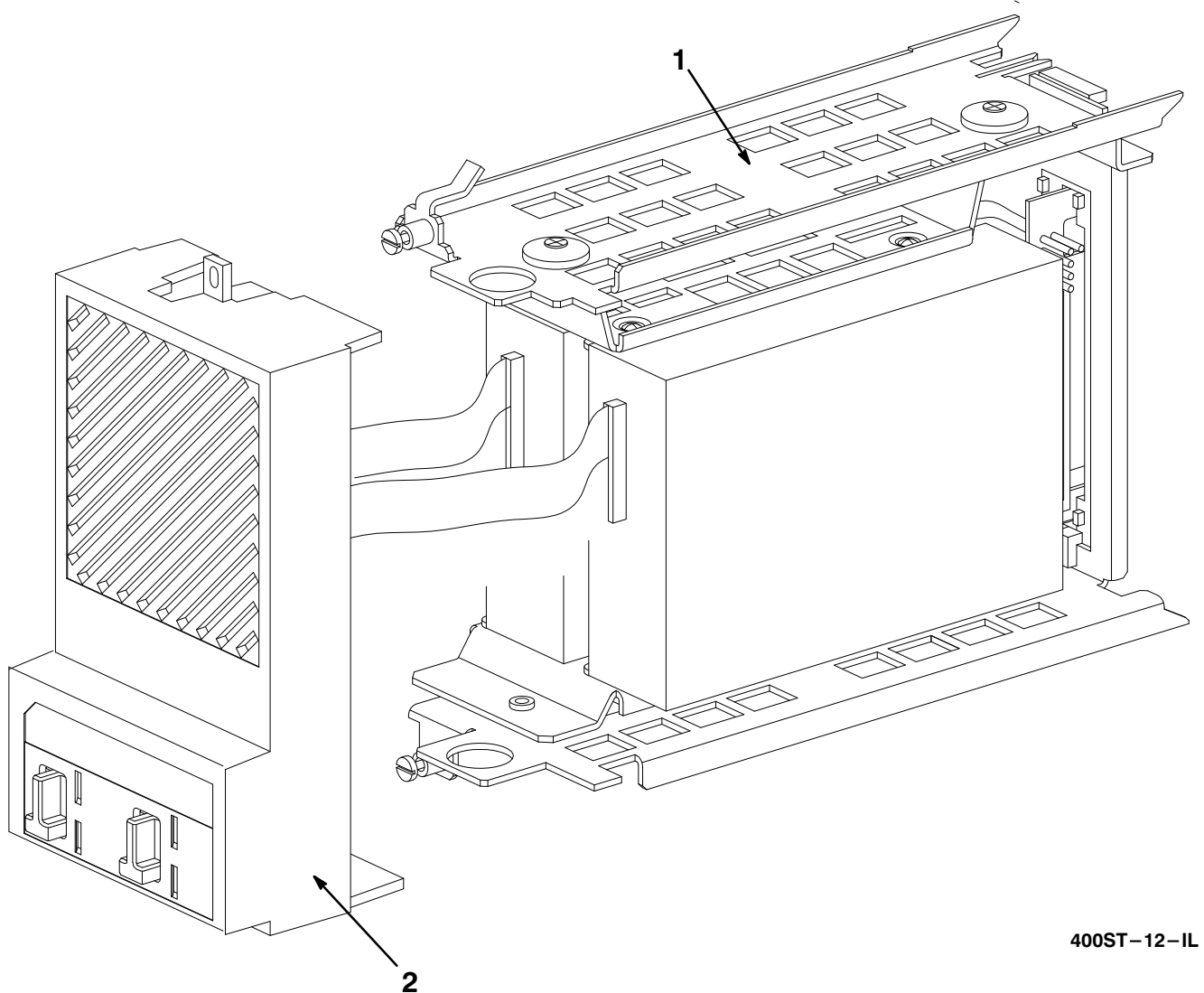
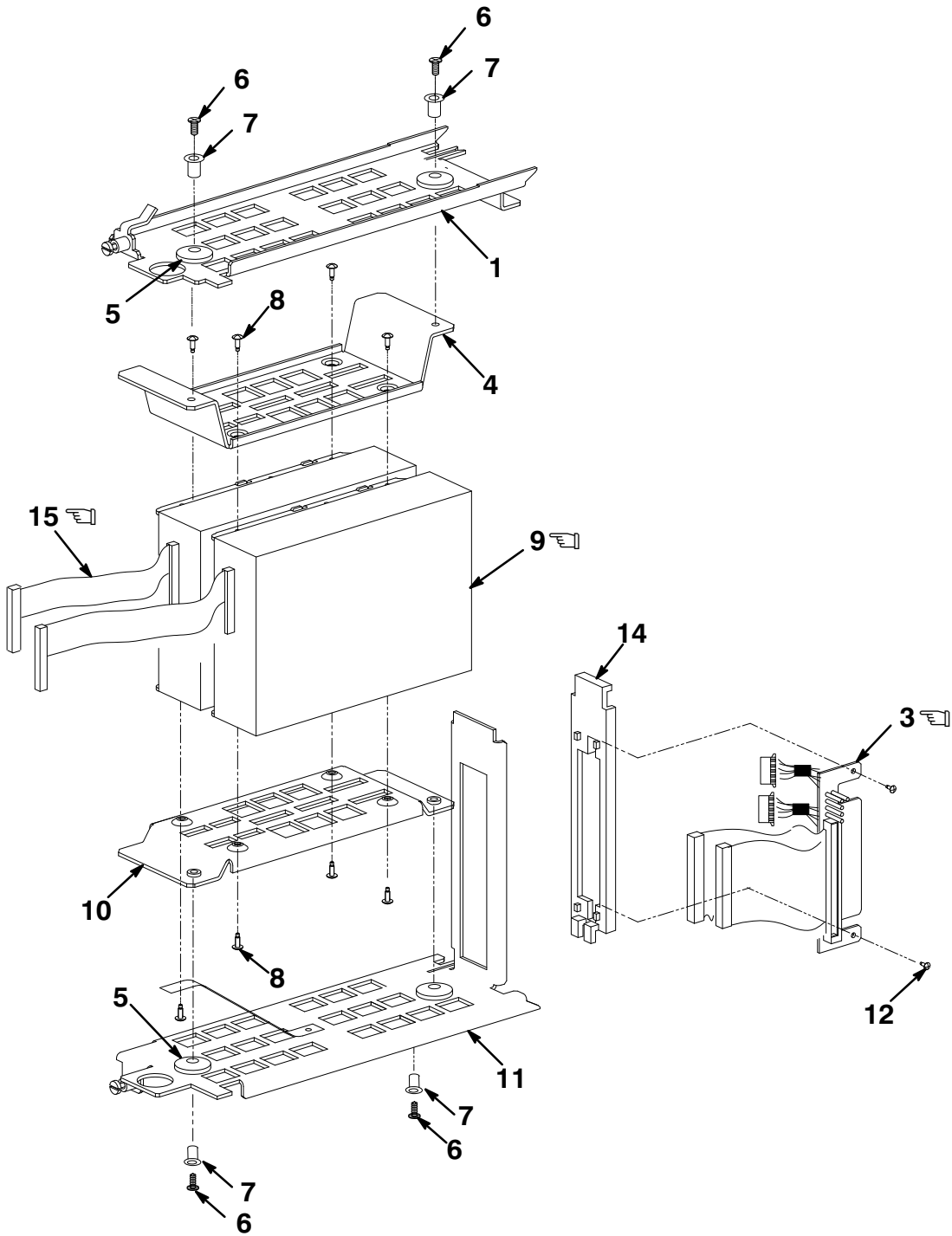

Figure 12. Storage Element, RF362 Dual



400ST-13-IL

Figure 13. Mounting Assembly, RF36 ISE

FIG. & ITEM NO.	DESCRIPTION	DIGITAL PART NO. ^c	ECO CUT-IN 70-29475 00000	USED ON CODE	REF FIG NO.
13-	MOUNTING ASSEMBLY, RF36 ISE (added) MOUNTING ASSEMBLY, RF36 ISE DUAL (added)	70-29475-05 70-29475-06	00002 00002	A B	11 12
1	*Bracket Assembly, Top Drive	74-44231-01			
2	This Item Is Not Used.				
3	*Module, Paddle	54-19787-03			
4	*Plate, Top Bracket Adapter	74-44233-01			
5	*Isolator, Shock Grommet	12-32626-04			
6	*Screw, Machine Flat Hd No. 6-32 x 5/8	90-06025-02			
7	*Isolator, Shock Ferrule	12-32626-03			
8	*Screw, Sems Phl Hd No. 6-32 x 1/4	90-10174-00			
9	*Storage Element, RF36E (See Note)	RF36-EA			
10	*Plate, Bottom Bracket Adapter	74-44234-01			
11	*Bracket Assembly, Bottom Drive	70-29476-01			
12	*Screw, Phl Pan Hd No. 4-40 x 1/4	90-09315-01			
13	This Item Is Not Used.				
14	*Bracket, Paddle Module	74-38830-01			
15	*Cable Assembly, RFP 7 in. Female Flat (See Note)	17-03428-01			
	NOTE: Use Quantity of 1 for 70-29475-05. Use Quantity of 2 for 70-29475-06.				

  INDICATES FRU LEVEL PARTS.

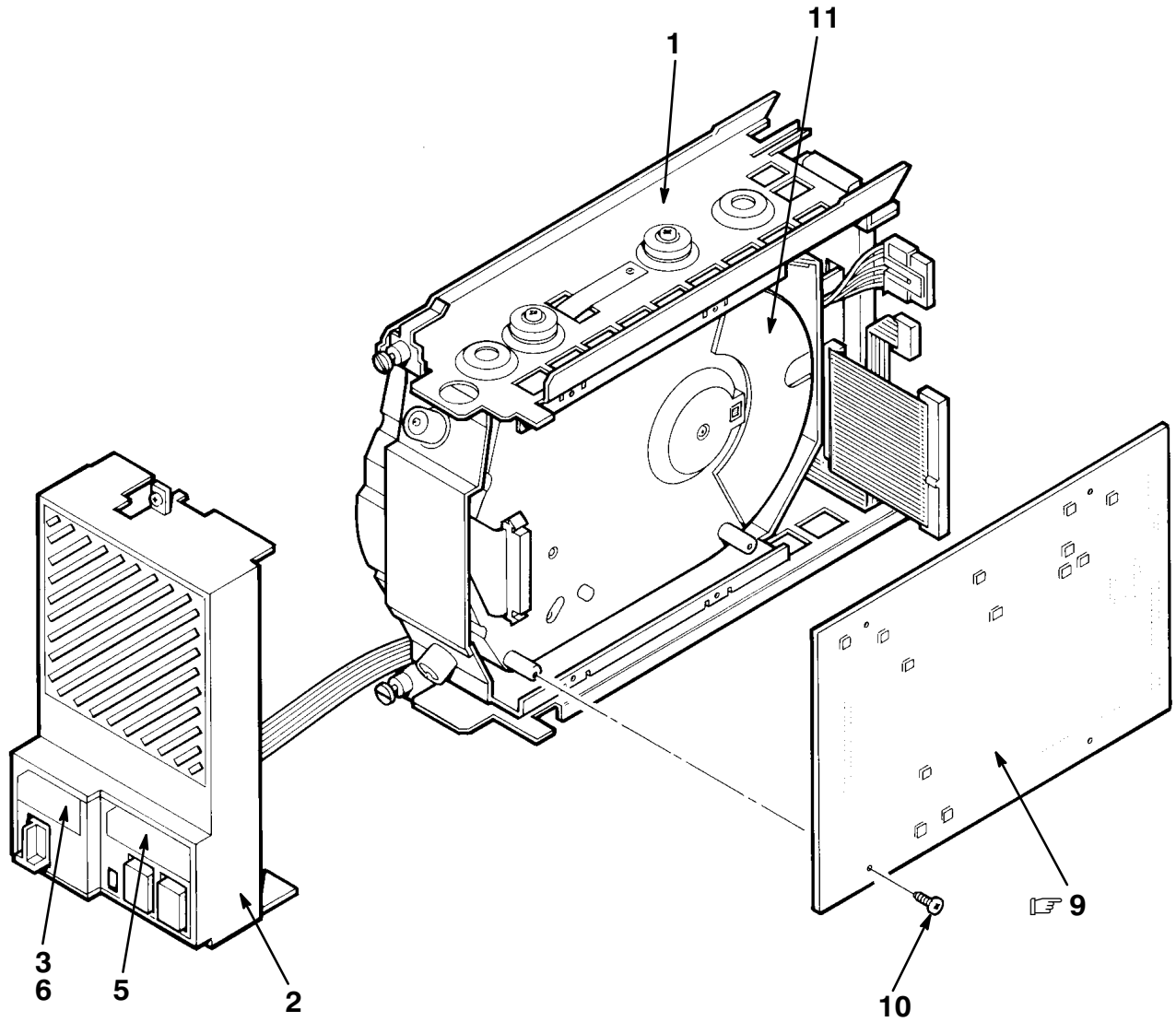

400ST-14-SC

Figure 14. Storage Element, RF71E

FIG. & ITEM NO.	DESCRIPTION	DIGITAL PART NO. ^B	ECO CUT-IN RF71E 00000	USED ON CODE	REF FIG NO.
14-	STORAGE ELEMENT, RF71E Code A – Used on RF71E-AA Code B – Used on RF71E-AF	RF71E-AA RF71E-AF		A B	
1	*MOUNTING ASSEMBLY, RF71 ISE	70-28087-01			18
2	*BEZEL ASSEMBLY, 5 1/4 INCH DISK DRIVE	70-27049-04			1,27
3	Label, "Switch Marker" (See Notes 1 and 2)	36-18940-02			
4	*Label, "Bar Code, Integrated Storage" (deleted) (Not Shown)	36-33151-02	00001		
5	*Label, "Drive No. 2 Language Variant" (See Note 3)	36-33183-02			
6	*Label, "No. 2 Language Variant" (See Note 3)	36-33183-04			
7	*Documentation, "Storage Device Add On Procedure" (Not Shown)	EK-BA44A-IN		B	
8	*Package Assembly (Not Shown)	37-01215-01		B	
9	Module, RF71 Drive (See Notes 1 and 4)	54-18316-XX			
10	Screw, Machine Phl Pan Hd No. 4-40 x 3/8 (See Note 1)	90-06011-01			
11	Mechanics Assembly, RF71 (See Note 1)	70-23557-01			
	Note 1: Not Part of RF71E-AA/AF Assembly, Shown for Reference Only.				
	Note 2: Item Ships With System.				
	Note 3: Language Specific Used In Place Of 01, 03.				
	Note 4: XX = Order Latest Version.				

INDICATES FRU LEVEL PARTS.

PARTS LIST

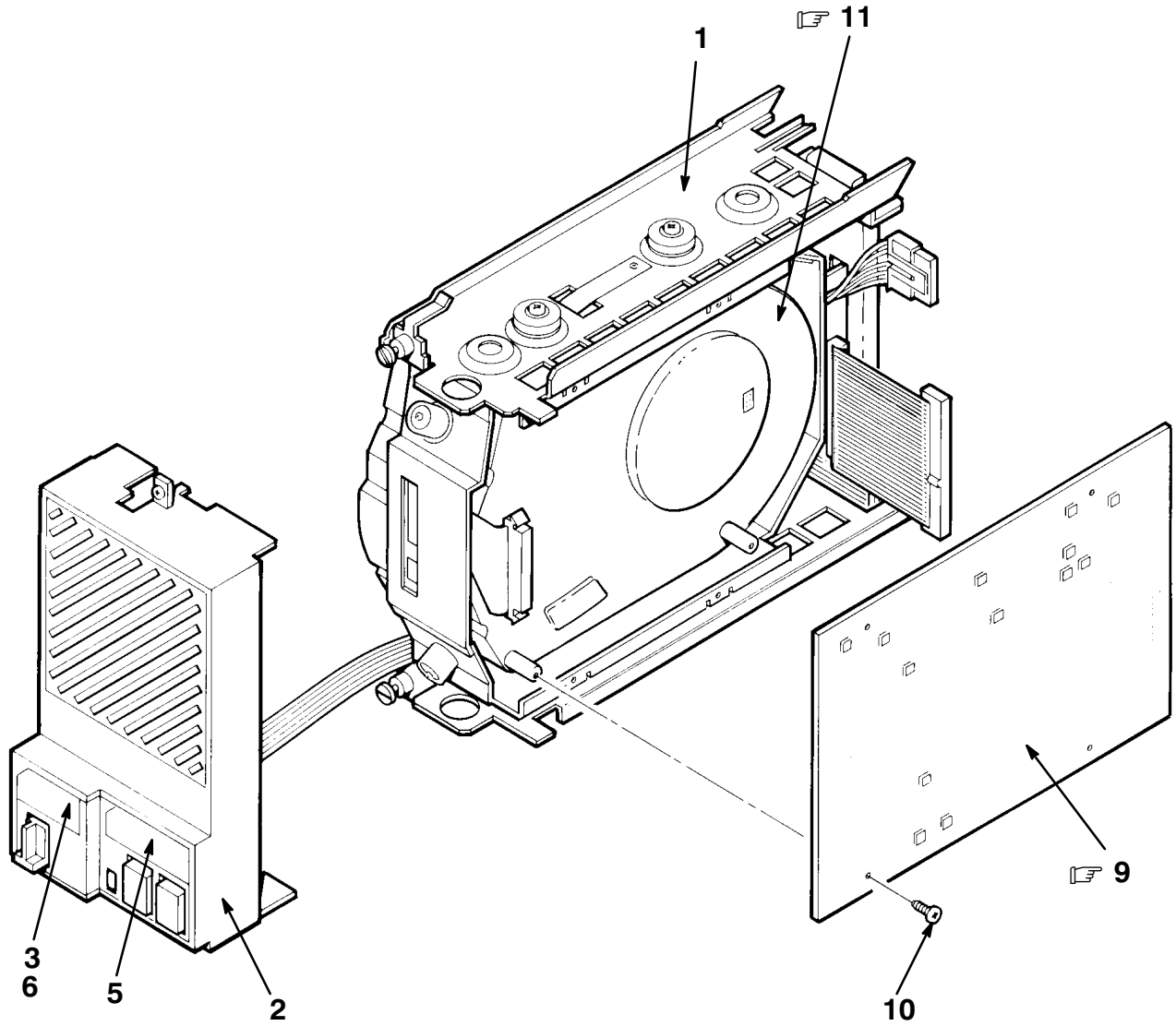

400ST-15-SC

Figure 15. Storage Element, RF72E

FIG. & ITEM NO.	DESCRIPTION	DIGITAL PART NO. ^B	ECO CUT-IN RF72E 00001	USED ON CODE	REF FIG NO.
15-	STORAGE ELEMENT, RF72E				
	Code A – Used on RF72E-AA	RF72E-AA		A	
	Code B – Used on RF72E-AF	RF72E-AF		B	
1	*MOUNTING ASSEMBLY, RF72 ISE	70-28087-02			18
2	*BEZEL ASSEMBLY, 5 1/4 INCH DSSI DISK DRIVE	70-27049-04			1,27
3	Label, "Switch Marker" (See Notes 1 and 2)	36-18940-02			
4	*Label, "Bar Code, Integrated Storage" (Not Shown) (deleted)	36-33151-04	00001		
5	*Label, "Drive No. 2 Language Variant" (See Note 3)	36-33183-02			
6	*Label, "No. 2 Language Variant" (See Note 3)	36-33183-04			
7	*Documentation, "Storage Device Add On Procedure" (Not Shown)	EK-BA44A-IN		B	
8	*Package Assembly (Not Shown)	37-01215-01		B	
9	Module, RF72 Drive (See Notes 1 and 4)	54-10091-XX			
10	Screw, Machine Phl Pan Hd No. 4-40 x 3/8 (See Note 1)	90-06011-01			
11	Mechanics Assembly, RF72 (See Note 1)	70-25972-01			
	Note 1: Not Part of RF72E-AA/AF Assembly, Shown For Reference Only.				
	Note 2: Item Ships With System.				
	Note 3: Language Specific, Used In Place Of 01, 03.				
	Note 4: XX = Order Latest Version.				

 INDICATES FRU LEVEL PARTS.

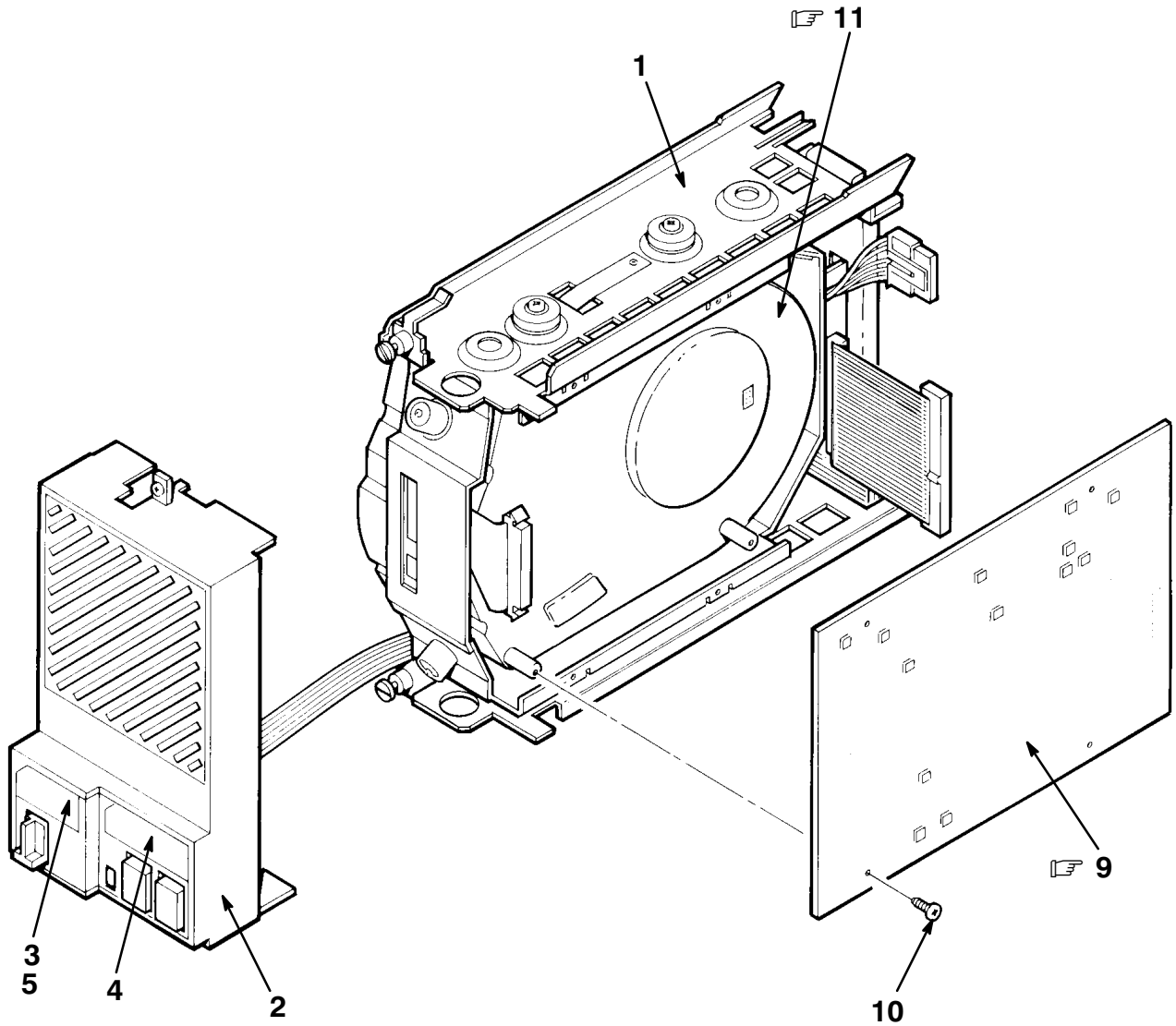

400ST-16-SC

Figure 16. Storage Element, RF73E

FIG. & ITEM NO.	DESCRIPTION	DIGITAL PART NO. ^A	ECO CUT-IN RF73E 00000	USED ON CODE	REF FIG NO.
16-	STORAGE ELEMENT, RF73E				
	Code A – Used on RF73E-AA	RF73E-AA		A	
	Code B – Used on RF73E-AF	RF73E-AF		B	
1	*MOUNTING ASSEMBLY, RF73 ISE	70-28087-03			18
2	*BEZEL ASSEMBLY, 5 1/4 INCH DISK DRIVE	70-27049-04			1,27
3	Label, "Switch Marker" (See Notes 1 and 2)	36-18940-02			
4	*Label, "Drive No. 2 Language Variant" (See Note 3)	36-33183-02			
5	*Label, "No. 2 Language Variant" (See Note 3)	36-33183-04			
6	*Documentation, "Storage Device Add On Procedure" (Not Shown)	EK-BA44A-IN		B	
7	*Package Assembly (Not Shown)	37-01215-01		B	
8	*Package Assembly (Bulk Shipment) (Not Shown)	37-01186-07		A	
9	Module, RF73 Drive (See Notes 1 and 4)	54-19119-XX			
10	Screw, Machine Phi Pan Hd No. 4-40 x 3/8 (See Note 1)	90-06011-01			
11	Mechanics Assembly, RF73 (See Note 1)	70-28814-01			
	<p>Note 1: Not Part of RF73E-AA/AF Assembly, Shown For Reference Only.</p> <p>Note 2: Item Ships With System.</p> <p>Note 3: Language Specific Used In Place Of 01, 03.</p> <p>Note 4: XX = Order Latest Version.</p>				

  INDICATES FRU LEVEL PARTS.

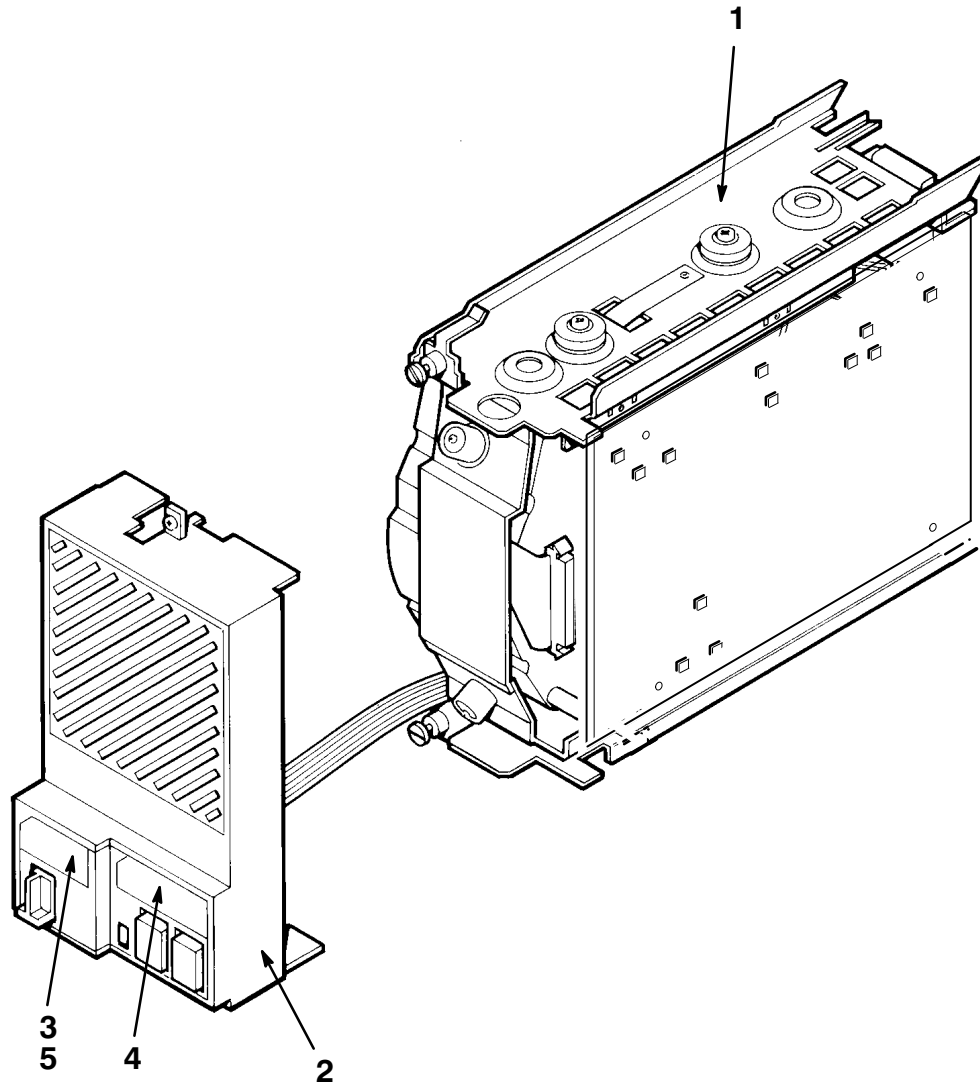

400ST-17-SC

Figure 17. Storage Element, RF74E

FIG. & ITEM NO.	DESCRIPTION	DIGITAL PART NO. ^A	ECO CUT-IN RF74E 00000	USED ON CODE	REF FIG NO.
17-	STORAGE ELEMENT, RF74E				
	Code A – Used on RF74E-AA Code B – Used on RF74E-AF	RF74E-AA RF74E-AF		A B	
1	*MOUNTING ASSEMBLY, RF74 ISE	70-28087-05			18
2	*BEZEL ASSEMBLY, DISK DRIVE	70-27049-04			1,27
3	Label, "Switch Marker" (See Notes 1 and 2)	36-18940-02			
4	*Label, "Drive No. 2 Language Variant" (See Note 3)	36-33183-02			
5	*Label, "No. 2 Language Variant" (See Note 3)	36-33183-04			
6	*Documentation, "Storage Device Add On Procedure" (Not Shown)	EK-BA44A-IN		B	
7	*Package Assembly (Not Shown)	37-01215-01		B	
	*Package Assembly (Bulk Shipment) (Not Shown)	37-01186-07		A	
	Note 1: Not Part of RF74E-AA/AF Assembly, Shown For Reference Only.				
	Note 2: Item Ships With System.				
	Note 3: Language Specific Used In Place Of 01, 03.				

INDICATES FRU LEVEL PARTS.

PARTS LIST

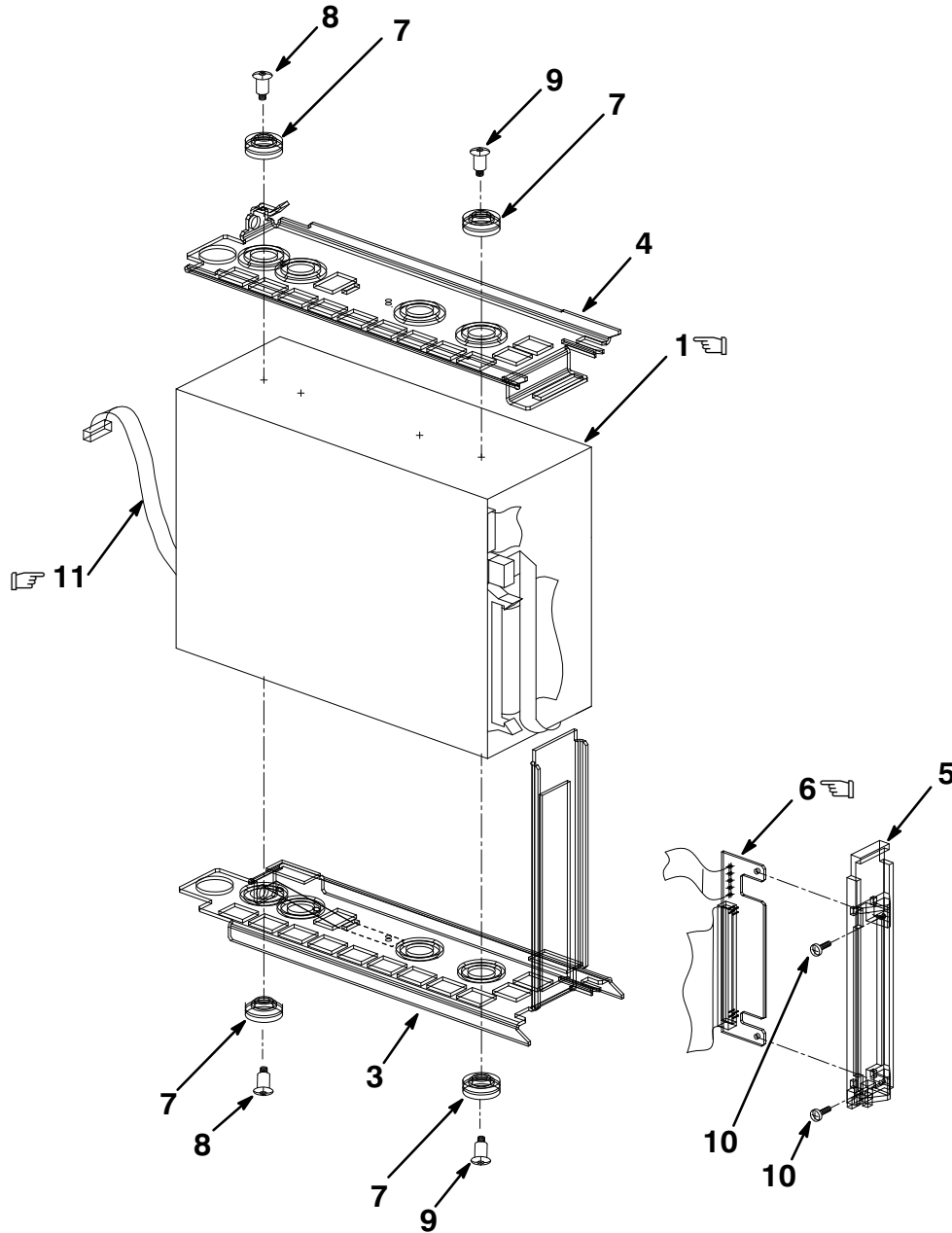

400ST-18-IL

Figure 18. Mounting Assembly, RF71/RF72/RF73/RF74 ISE

FIG. & ITEM NO.	DESCRIPTION	DIGITAL PART NO.	ECO CUT-IN 70-28087 00000	USED ON CODE	REF FIG NO.
18-	MOUNTING ASSEMBLY, RF71 ISE	70-28087-01		A	14
	MOUNTING ASSEMBLY, RF72 ISE	70-28087-02		B	15
	MOUNTING ASSEMBLY, RF73 ISE (added)	70-28087-03	00003	C	16
	MOUNTING ASSEMBLY, RF74 ISE (added)	70-28087-05	00005	D	17
☞ 1	*Disk Drive Assembly (RF71)	RF71-EA		A	
☞	*Disk Drive Assembly (RF72)	RF72-EA		B	
☞	*Disk Drive Assembly (RF73) (added)	RF73-EA	00003	C	
☞	*Disk Drive Assembly (RF74) (added)	RF74-EA	00005	D	
2	*This Item Not Used				
3	*Bracket Assembly, Bottom Drive	70-27412-01			
4	*Bracket Assembly, Top Drive	74-38828-01			
5	*Bracket, Paddle Board	74-38830-01			
☞6	*Module, DSSI Interface Card	54-19787-01			
7	*Isolator, Shock (deleted)	12-32626-01	00001		
	*Isolator, Shock Grommet (added)	12-32626-04	00001		
8	*Screw, Machine Phl Pan Hd No. 6-32 x 1/2 (deleted)	90-06024-02	00001		
	*Screw, Shoulder Hd No. 6-32 x 1/2 (added)	12-34462-01	00001		
9	*Screw, Machine Flat Hd No. 6-32 x 5/8 (deleted)	90-06025-02	00001		
	*Screw, Shoulder Hd No. 6-32 x 1/2 (added)	12-34462-01	00001		
10	*Screw, Phl Pan Hd No. 4-40 x 1/4	90-09315-01			
☞11	*Cable Assembly, 10 Cond	17-02706-01			

  INDICATES FRU LEVEL PARTS.

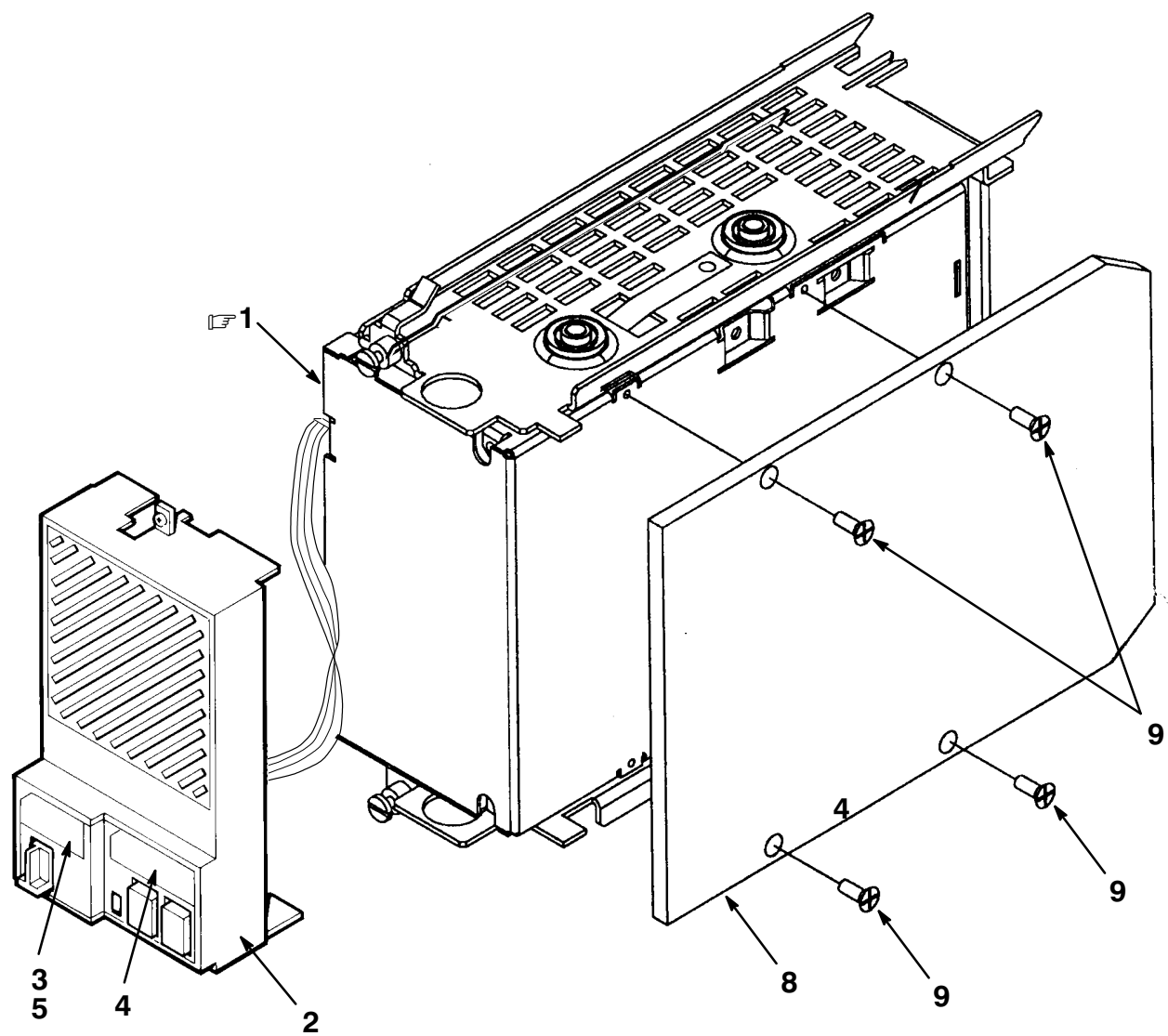

400ST-19-SC

Figure 19. Storage Element, EF51R

FIG. & ITEM NO.	DESCRIPTION	DIGITAL PART NO. ^c	ECO CUT-IN EF51R 00002	USED ON CODE	REF FIG NO.
19-	STORAGE ELEMENT, EF51R				1, 22
	Code A – Used on EF51R-AA	EF51R-AA		A	
	Code B – Used on EF51R-AF	EF51R-AF		B	
1	*Disk Drive Assembly, SSD, 100 MB w/Data Retention	70-29868-01			
2	*Bezel Assembly	70-27049-04			
3	Label, "Switch Marker" (See Notes 1 and 2)	36-18940-02			
4	*Label, "Drive No. 2 Language Variant" (See Note 3)	36-33183-02			
5	*Label, "No. 2 Language Variant" (See Note 3)	36-33183-04			
6	*Documentation, "Storage Device Add On Procedure" (Not Shown)	EK-BA44A-IN			
	*Documentation, "EF5XX Series Solid State Disk" (Not Shown)	EK-EF5XX-UG			
7	*Package Assembly (Not Shown)	37-01215-01			
8	*Plate, Skid (See Note 4)	74-25652-02			
9	*Screw, Mach Pan Hd No. 6-32 x 1/4 (See Note 4)	90-06020-01			
	Note 1: Not Part of EF51R-AA/AF Assembly, Shown For Reference Only.				
	Note 2: Item Ships With System.				
	Note 3: Language Specific Used In Place Of 01, 03.				
	Note 4: Remove Items 8 and 9 Before Installation Into a BA400 Series Enclosure.				

INDICATES FRU LEVEL PARTS.

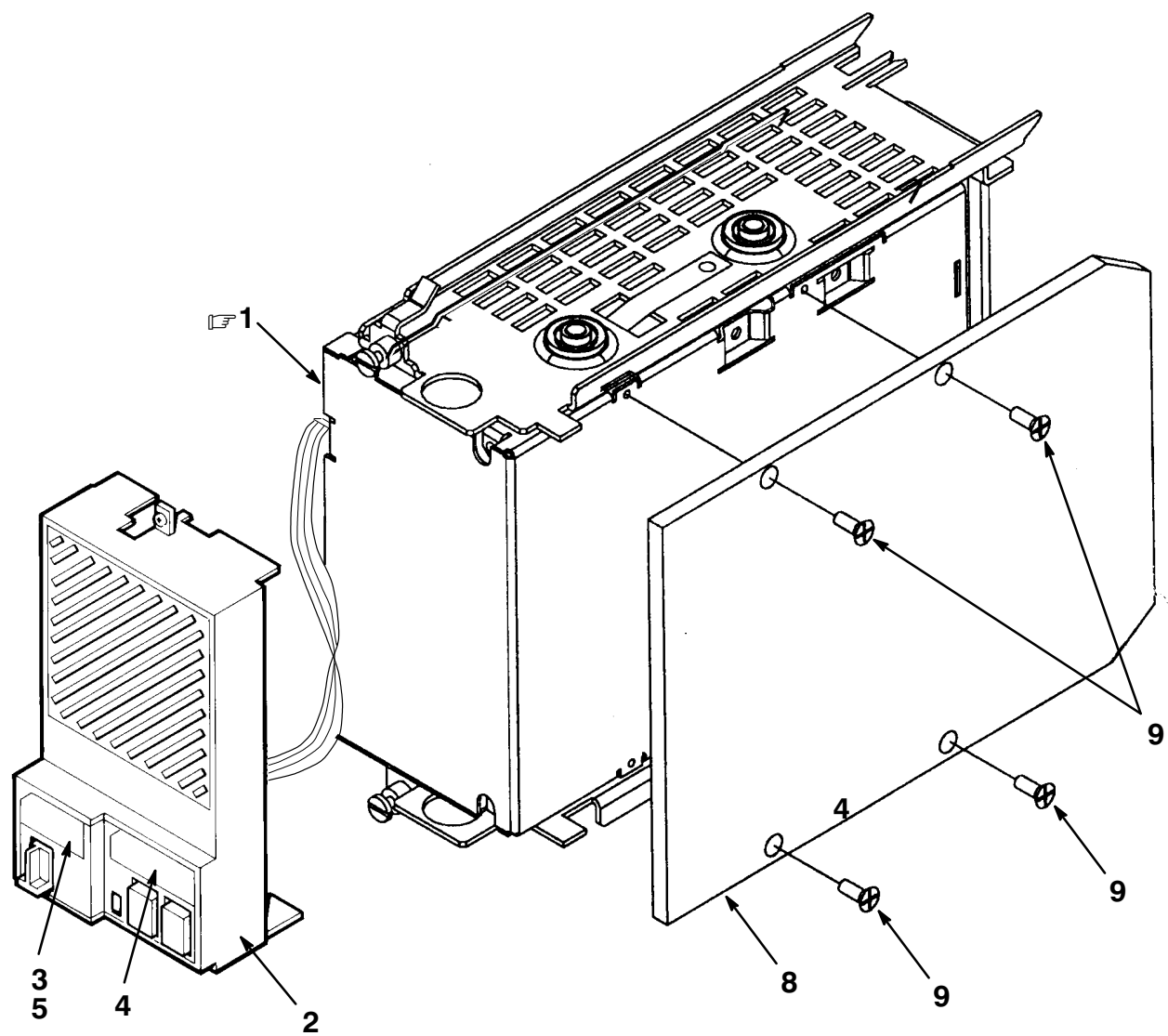

400ST-20-SC

Figure 20. Storage Element, EF52R

FIG. & ITEM NO.	DESCRIPTION	DIGITAL PART NO. ^c	ECO CUT-IN EF52R 00002	USED ON CODE	REF FIG NO.
20-	STORAGE ELEMENT, EF52R				1, 22
	Code A – Used on EF52R-AA	EF52R-AA		A	
	Code B – Used on EF52R-AF	EF52R-AF		B	
1	*Disk Drive Assembly, SSD, 200 MB w/Data Retention	70-29868-03			
2	*Bezel Assembly	70-27049-04			
3	Label, "Switch Marker" (See Notes 1 and 2)	36-18940-02			
4	*Label, "Drive No. 2 Language Variant" (See Note 3)	36-33183-02			
5	*Label, "No. 2 Language Variant" (See Note 3)	36-33183-04			
6	*Documentation, "Storage Device Add On Procedure" (Not Shown)	EK-BA44A-IN			
	*Documentation, "EF5XX Series Solid State Disk" (Not Shown)	EK-EF5XX-UG			
7	*Package Assembly (Not Shown)	37-01215-01			
8	*Plate, Skid (See Note 4)	74-25652-02			
9	*Screw, Mach Pan Hd No. 6-32 x 1/4 (See Note 4)	90-06020-01			
	Note 1: Not Part of EF52R-AA/AF Assembly, Shown For Reference Only.				
	Note 2: Item Ships With System.				
	Note 3: Language Specific Used In Place Of 01, 03.				
	Note 4: Remove Items 8 and 9 Before Installation Into a BA400 Series Enclosure.				

  INDICATES FRU LEVEL PARTS.

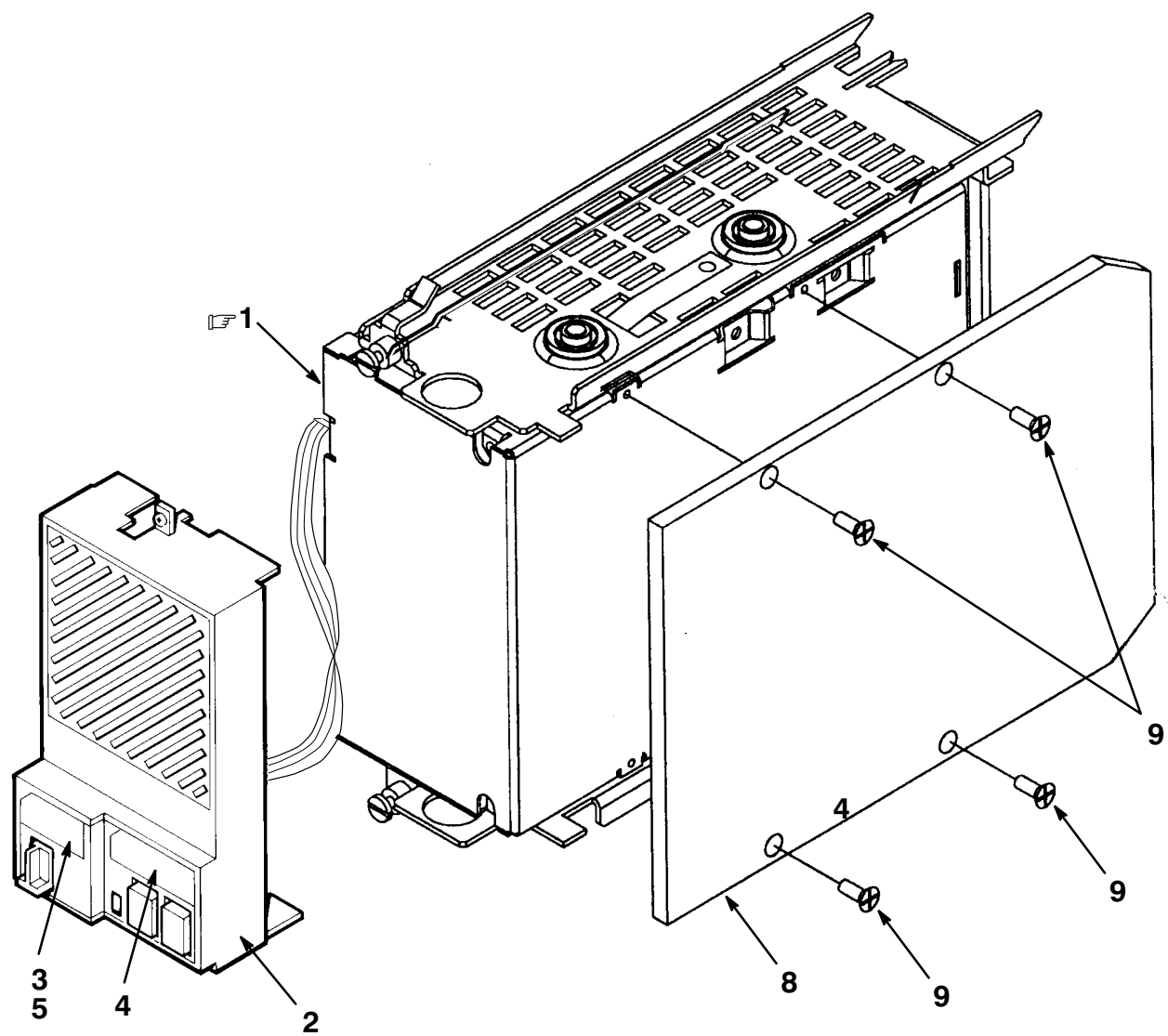

400ST-21-SC

Figure 21. Storage Element, EF53

FIG. & ITEM NO.	DESCRIPTION	DIGITAL PART NO. ^A	ECO CUT-IN EF53 00000	USED ON CODE	REF FIG NO.
21-	STORAGE ELEMENT, EF53				1, 22
	Code A – Used on EF53-AA	EF52R-AA		A	
	Code B – Used on EF53-AF	EF52R-AF		B	
1	*Disk Drive Assembly, SSD, 250 MB	70-29869-01			
2	*Bezel Assembly	70-27049-04			
3	Label, "Switch Marker" (See Notes 1 and 2)	36-18940-02			
4	*Label, "Drive No. 2 Language Variant" (See Note 3)	36-33183-02			
5	*Label, "No. 2 Language Variant" (See Note 3)	36-33183-04			
6	*Documentation, "Storage Device Add On Procedure" (Not Shown)	EK-BA44A-IN			
	*Documentation, "EF5XX Series Solid State Disk" (Not Shown)	EK-EF5XX-UG			
7	*Package Assembly (Not Shown)	37-01215-01			
8	*Plate, Skid (See Note 4)	74-25652-02			
9	*Screw, Mach Pan Hd No. 6-32 x 1/4 (See Note 4)	90-06020-01			
	Note 1: Not Part of EF52R-AA/AF Assembly, Shown For Reference Only.				
	Note 2: Item Ships With System.				
	Note 3: Language Specific Used In Place Of 01, 03.				
	Note 4: Remove Items 8 and 9 Before Installation Into a BA400 Series Enclosure.				

✎ ✎ INDICATES FRU LEVEL PARTS.

PARTS LIST

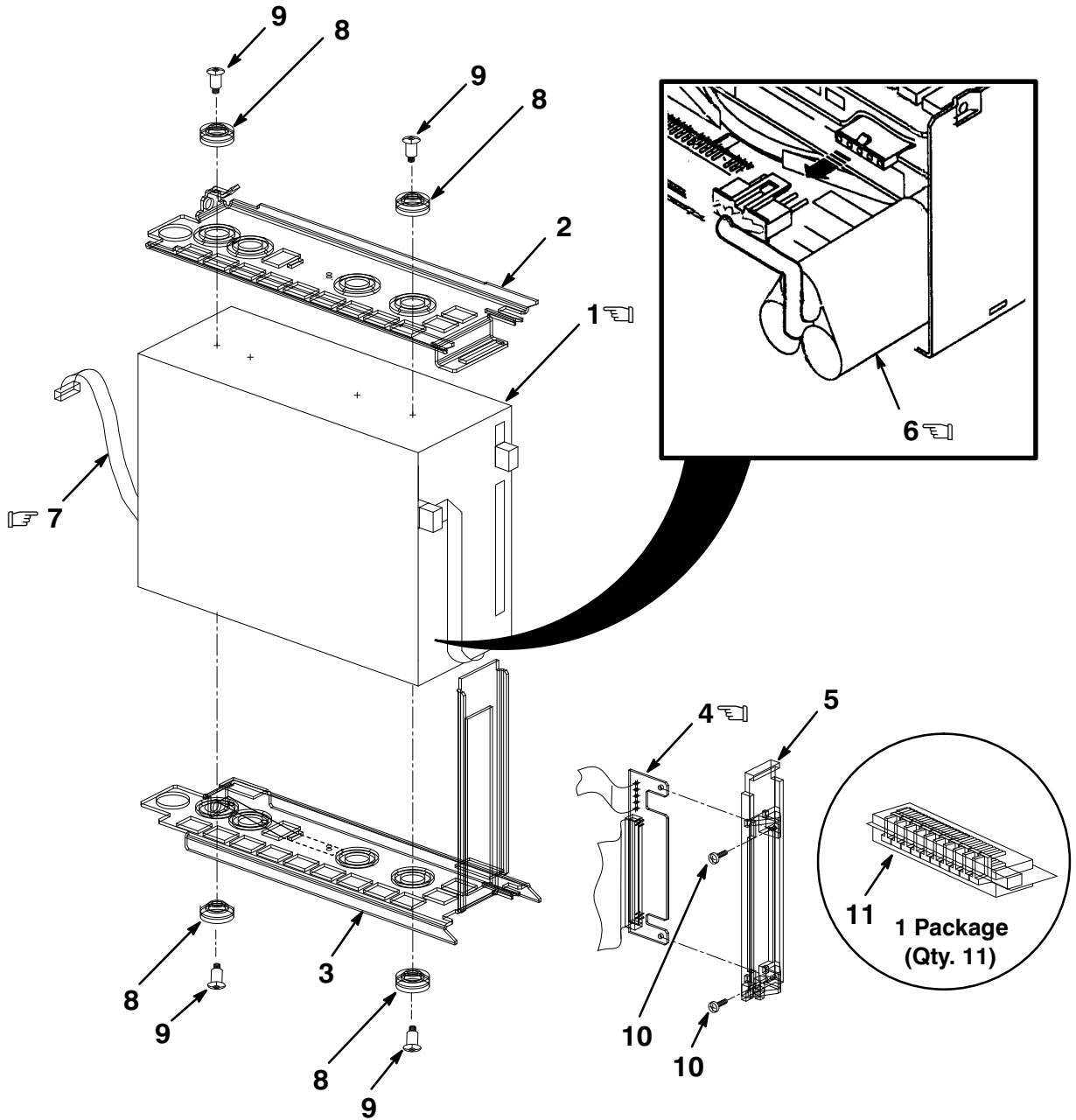

400ST-22-IL

Figure 22. Mounting Assembly, EF51R/EF52R/EF53 ISE

FIG. & ITEM NO.	DESCRIPTION	DIGITAL PART NO.	ECO CUT-IN	USED ON CODE	REF FIG NO.
22-	MOUNTING ASSEMBLY, EF51R/EF52R/EF53 ISE				
	Code A – Used on EF51R-AA/AF			A	19
	Code B – Used on EF52R-AA/AF			B	20
	Code C – Used on EF53-AA/AF			C	21
☞ 1	*Disk Drive Assembly, SSD, 100 MB w/Data Retention	70-29868-01		A	
☞	*Disk Drive Assembly, SSD, 200 MB w/Data Retention	70-29868-03		B	
☞	*Disk Drive Assembly, SSD, 250 MB	70-29869-01		C	
2	*Bracket Assembly, Top Drive	70-30268-01			
3	*Bracket Assembly, Bottom Drive	70-30269-01			
☞ 4	*Module, DSSI Interface Card	54-19787-01			
5	*Bracket, Paddle Board	74-38830-01			
☞ 6	*Battery Pack	12-19245-01			
☞ 7	*Cable Assembly, 10 Cond	17-02706-01			
8	*Isolator, Shock, Ferrule	12-32626-03			
	*Isolator, Shock, Grommet	12-32626-04			
9	*Screw, Mach Flat Hd No. 6-32 x 5/8	90-06025-02			
10	*Screw, Phl Pan Hd No. 4-40 x 1/4	90-09315-01			
11	*Encoder Set, Lens (DSSI Unit ID Plug)	12-28766-19			

INDICATES FRU LEVEL PARTS.

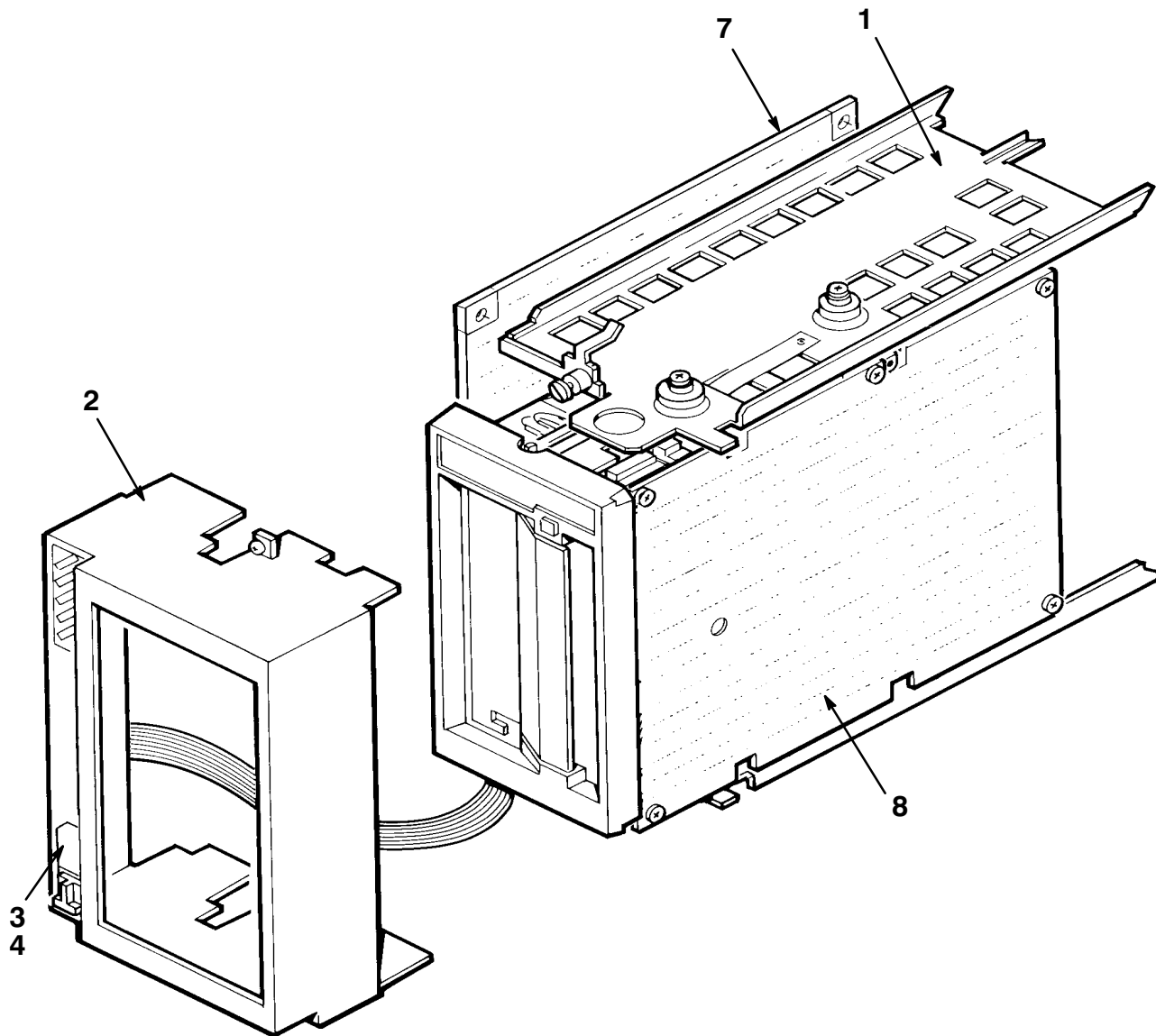

400ST-23-SC

Figure 23. Storage Element, TF85E

FIG. & ITEM NO.	DESCRIPTION	DIGITAL PART NO. ^A	ECO CUT-IN TF85E 00000	USED ON CODE	REF FIG NO.
23-	STORAGE ELEMENT, TF85E				
	Code A – Used on TF85E–JA	TF85E–JA		A	
	Code B – Used on TF85E–JF	TF85E–JF		B	
1	*MOUNTING ASSEMBLY, TF85 ISE	70–28092–01			24
2	*BEZEL ASSEMBLY, TAPE DRIVE	70–27050–03			1,29
3	Label, “Switch Marker” (See Notes 1 and 2)	36–18940–02			
4	*Label, “Bus ID” (Language Variant) (See Note 3)	36–33181–02			
5	*Documentation, “Storage Device Add On Procedure” (Not Shown)	EK–BA44A–IN		B	
6	*Package Assembly (Not Shown)	37–01215–06		B	
7	Module, TF85 (See Note 1)	54–19089–01			
8	Mechanics Assembly, TF85 (See Note 1)	TK85–BX			
	Note 1: Not Part of TF85E–JA/JF Assembly, Shown for Reference Only.				
	Note 2: Item Ships With System.				
	Note 3: Language Specific, Used In Place Of 01.				

 INDICATES FRU LEVEL PARTS.

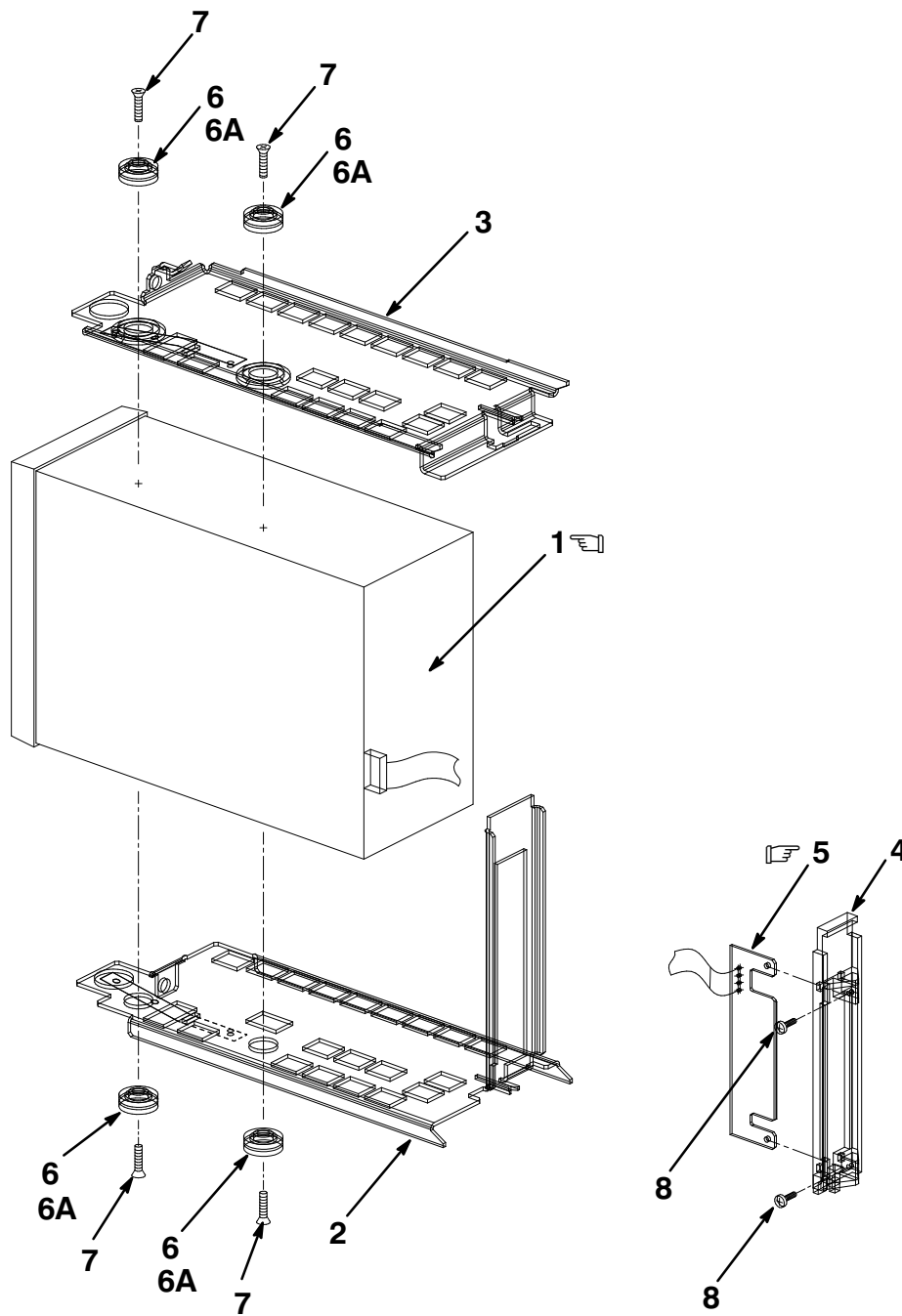

400ST-24-IL

Figure 24. Mounting Assembly, TF85 ISE

FIG. & ITEM NO.	DESCRIPTION	DIGITAL PART NO. ^A	ECO CUT-IN 70-28092 00000	USED ON CODE	REF FIG NO.
24-	MOUNTING ASSEMBLY, TF85 ISE	70-28092-01			23
☞1	*Tape Drive Assembly	TF85-BA			
2	*Bracket Assembly, Bottom Tape Drive	70-27413-01			
3	*Bracket Assembly, Top Tape Drive	70-27457-01			
4	*Bracket, Paddle Board	74-38830-01			
☞5	*Module, Interface Card	54-19787-02			
6	*Isolator, Shock (Ferrule)	12-32626-03			
6A	*Isolator, Shock (Grommet)	12-32626-04			
7	*Screw, Machine Flat Hd No. 6-32 x 5/8	90-06025-02			
8	*Screw, Phi Pan Hd No. 4-40 x 1/4	90-09315-01			

INDICATES FRU LEVEL PARTS.

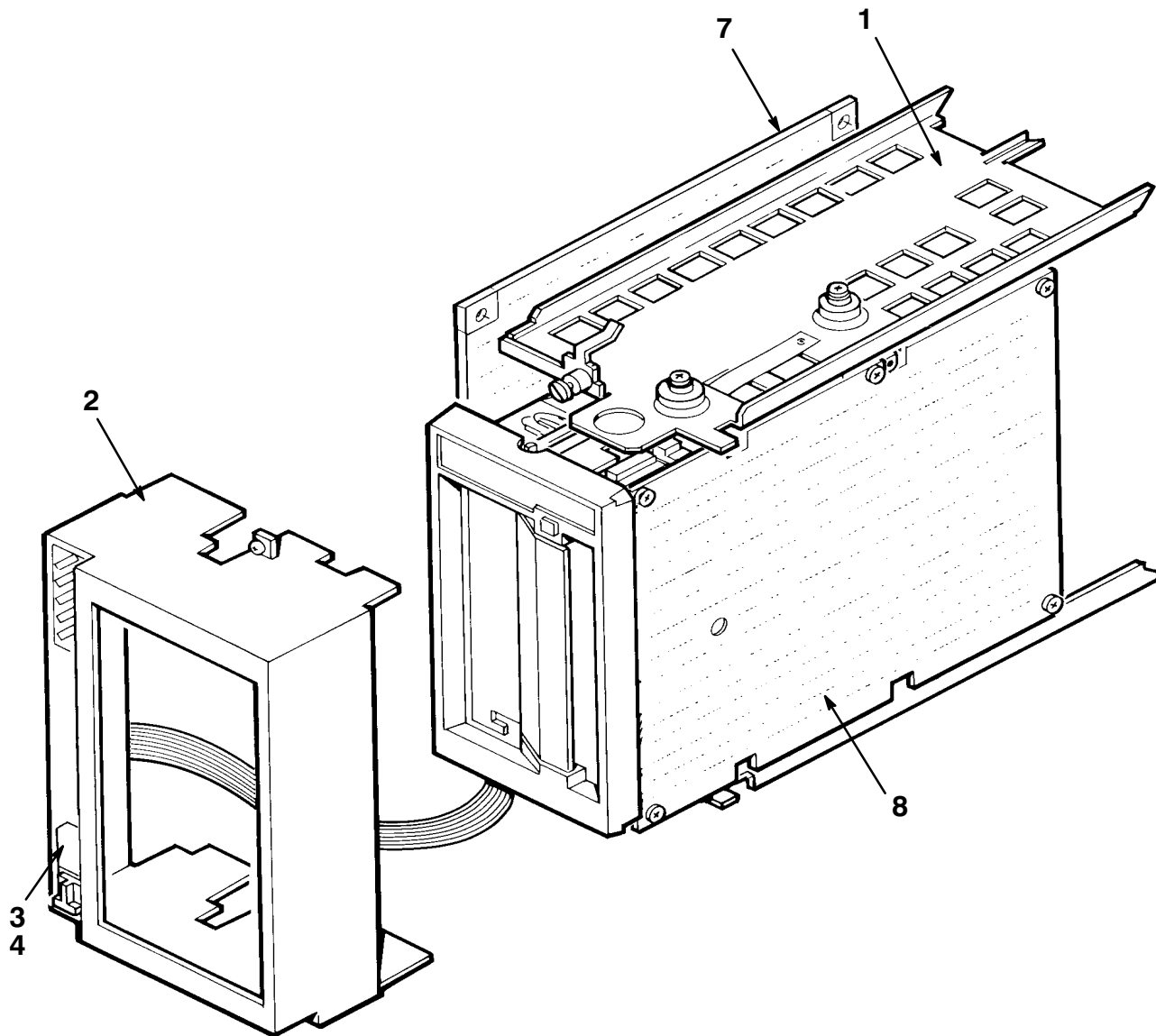

400ST-25-SC

Figure 25. Storage Element, TF86E

FIG. & ITEM NO.	DESCRIPTION	DIGITAL PART NO. ^A	ECO CUT-IN TF86E 00000	USED ON CODE	REF FIG NO.
25-	STORAGE ELEMENT, TF86E				1
	Code A – Used on TF86E–JA	TF86E–JA		A	
	Code B – Used on TF86E–JF	TF86E–JF		B	
1	*MOUNTING ASSEMBLY, TF86 ISE	70–28092–03			26
2	*BEZEL ASSEMBLY, TAPE DRIVE	70–27050–03			1,29
3	Label, “Switch Marker” (See Notes 1 and 2)	36–18940–02			
4	*Label, “Bus ID” (Language Variant) (See Note 3)	36–33181–02			
5	*Documentation, “Storage Device Add On Procedure” (Not Shown)	EK–BA44A–IN		B	
6	*Package Assembly (Not Shown)	37–01215–06		B	
7	Module, TF85/TF86 (See Note 1)	54–19089–01			
8	Mechanics Assembly, TF86 (See Note 1)	TK86–BX			
	Note 1: Not Part of TF86E–JA/JF Assembly, Shown for Reference Only.)				
	Note 2: Item Ships With System.				
	Note 3: Language Specific, Used In Place Of 01.				

  INDICATES FRU LEVEL PARTS.

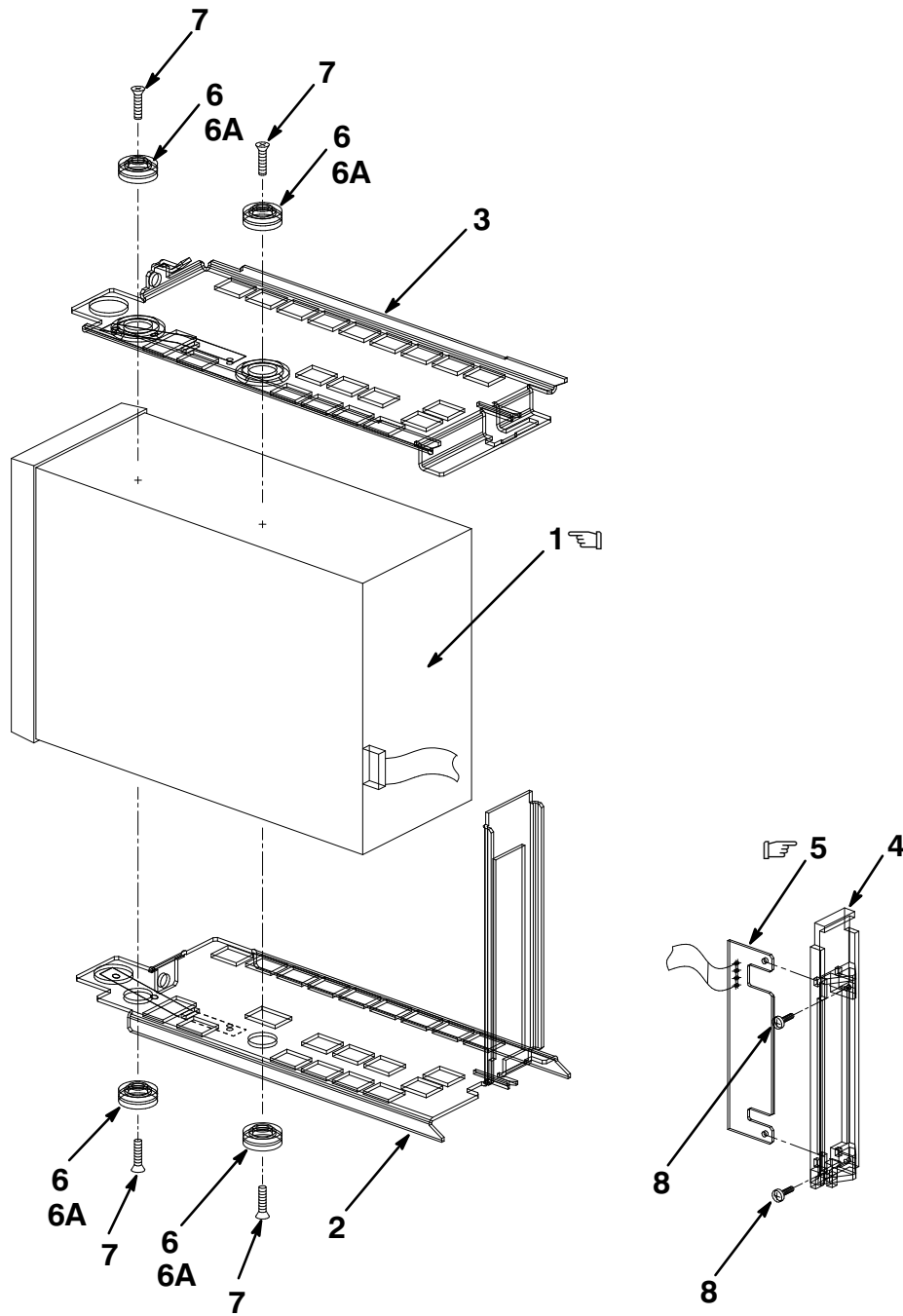

400ST-26-IL

Figure 26. Mounting Assembly, TF86 ISE

FIG. & ITEM NO.	DESCRIPTION	DIGITAL PART NO. ^A	ECO CUT-IN 70-28092 00000	USED ON CODE	REF FIG NO.
26-	MOUNTING ASSEMBLY, TF86 ISE	70-28092-03			25
☞1	*Tape Drive Assembly	TF86-BA			
2	*Bracket Assembly, Bottom Tape Drive	70-27413-01			
3	*Bracket Assembly, Top Tape Drive	70-27457-01			
4	*Bracket, Paddle Board	74-38830-01			
☞5	*Module, Interface Card	54-19787-02			
6	*Isolator, Shock (Ferrule)	12-32626-03			
6A	*Isolator, Shock (Grommet)	12-32626-04			
7	*Screw, Machine Flat Hd No. 6-32 x 5/8	90-06025-02			
8	*Screw, Phi Pan Hd No. 4-40 x 1/4	90-09315-01			

INDICATES FRU LEVEL PARTS.

PARTS LIST

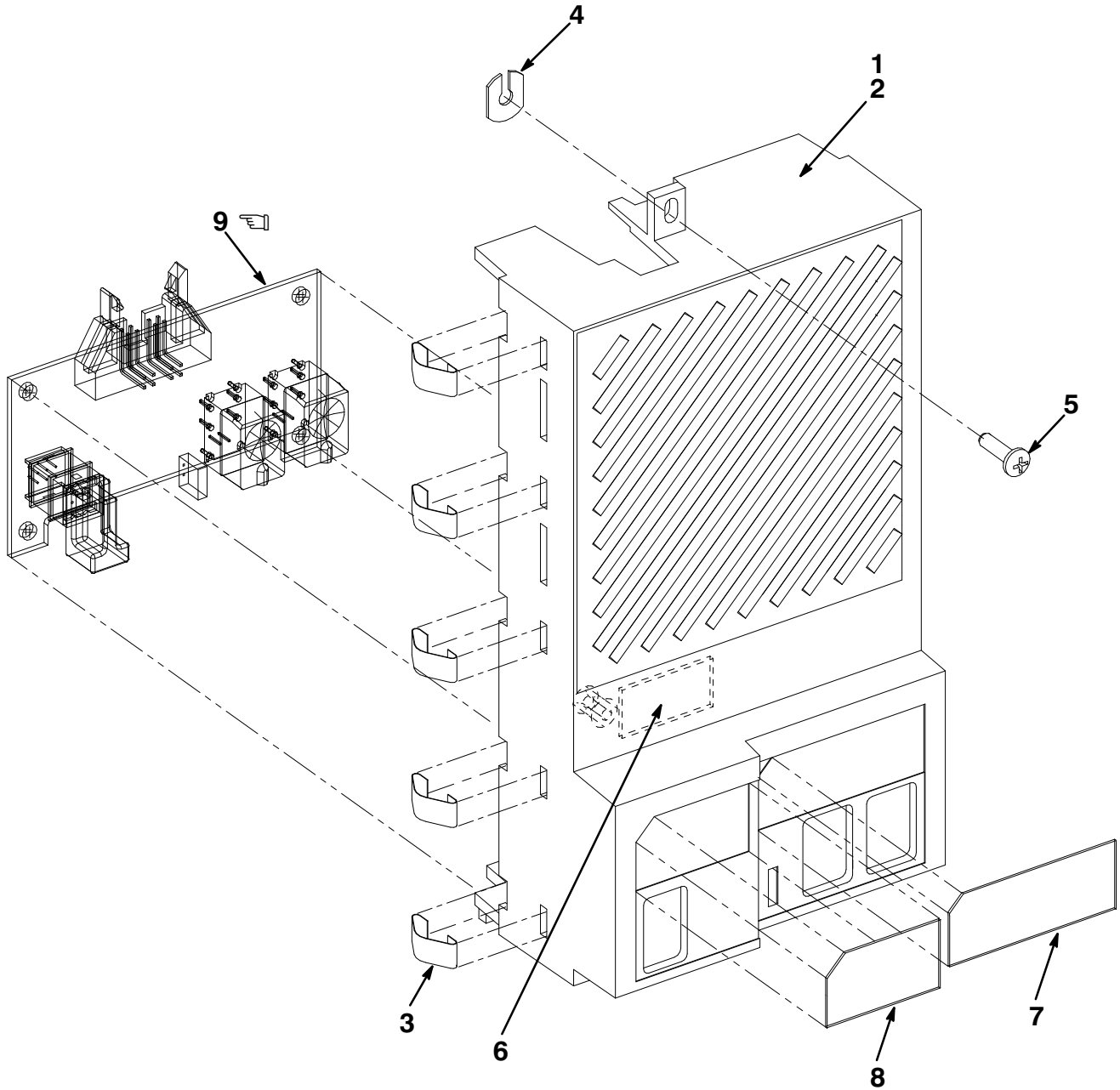

400ST-27-IL

Figure 27. Bezel Assembly, 5 1/4 Inch DSSI Disk Drive

FIG. & ITEM NO.	DESCRIPTION	DIGITAL PART NO.	A ECO CUT-IN 70-27049 00000	USED ON CODE	REF FIG NO.
27-	BEZEL ASSEMBLY, 5 1/4 INCH DSSI DISK DRIVE	70-27049-04			14,15 16,17
1	*BEZEL ASSEMBLY, DISK DRIVE	70-27049-01			
2	**Bezel, RF71 Drive	74-39272-01			
3	**Finger, Grounding	12-26922-01			
4	**Washer, Retainer	12-30421-01			
5	**Screw, Phi Pan Hd No. 6-32 x 5/16	90-06021-01			
6	**Tape, Velcro	12-32980-01			
7	*Label, "Drive Control"	36-33183-01			
8	*Label, "Bus ID"	36-33183-03			
9	*Module, DSSI Front Panel	54-19791-01			

FIG. & ITEM NO.	DESCRIPTION	DIGITAL PART NO. ^B	ECO CUT-IN 70-29478 00000	USED ON CODE	REF FIG NO.
28-	BEZEL ASSEMBLY, 3 1/2 INCH DSSI DISK DRIVE	70-29478-01			1,5,6 8,9 10,11
1	*Bezel, Blank	74-44325-01	00001		
2	*Module, DSSI Remote Front Panel	54-21530-01			
3	Finger, Non-Snag Grounding (Not Part of This Assembly, Shown for Reference Only.)	12-26922-01			

  INDICATES FRU LEVEL PARTS.

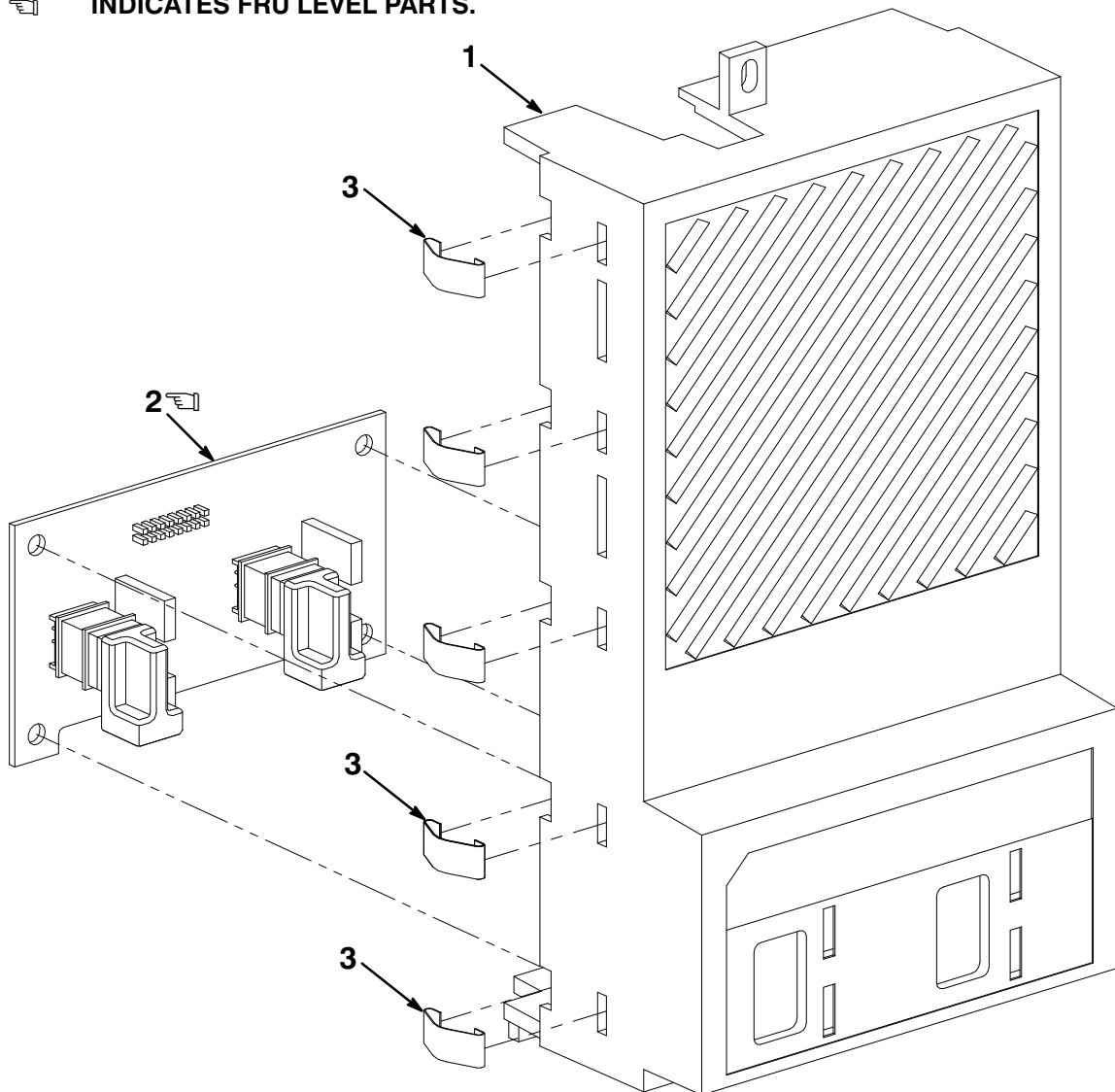

400ST-28-IL

Figure 28. Bezel Assembly, 3 1/2 Inch DSSI Disk Drive

FIG. & ITEM NO.	DESCRIPTION	DIGITAL PART NO. ^B	ECO CUT-IN 70-27050 00000	USED ON CODE	REF FIG NO.
29-	BEZEL ASSEMBLY, TAPE DRIVE	70-27050-03			1,23
1	**BEZEL ASSEMBLY, TAPE DRIVE	70-27050-01			
2	**Bezel, Tape Drive	74-39273-01			
3	**Finger, Grounding	12-26922-01			
4	**Washer, Retaining	12-30421-01			
5	**Screw, Phi Pan Hd No. 6-32 x 5/16	90-06021-01			
6	*Label, "Bus ID"	36-33181-01			
7	*Module, Device ID Panel	54-20336-01			

  INDICATES FRU LEVEL PARTS.

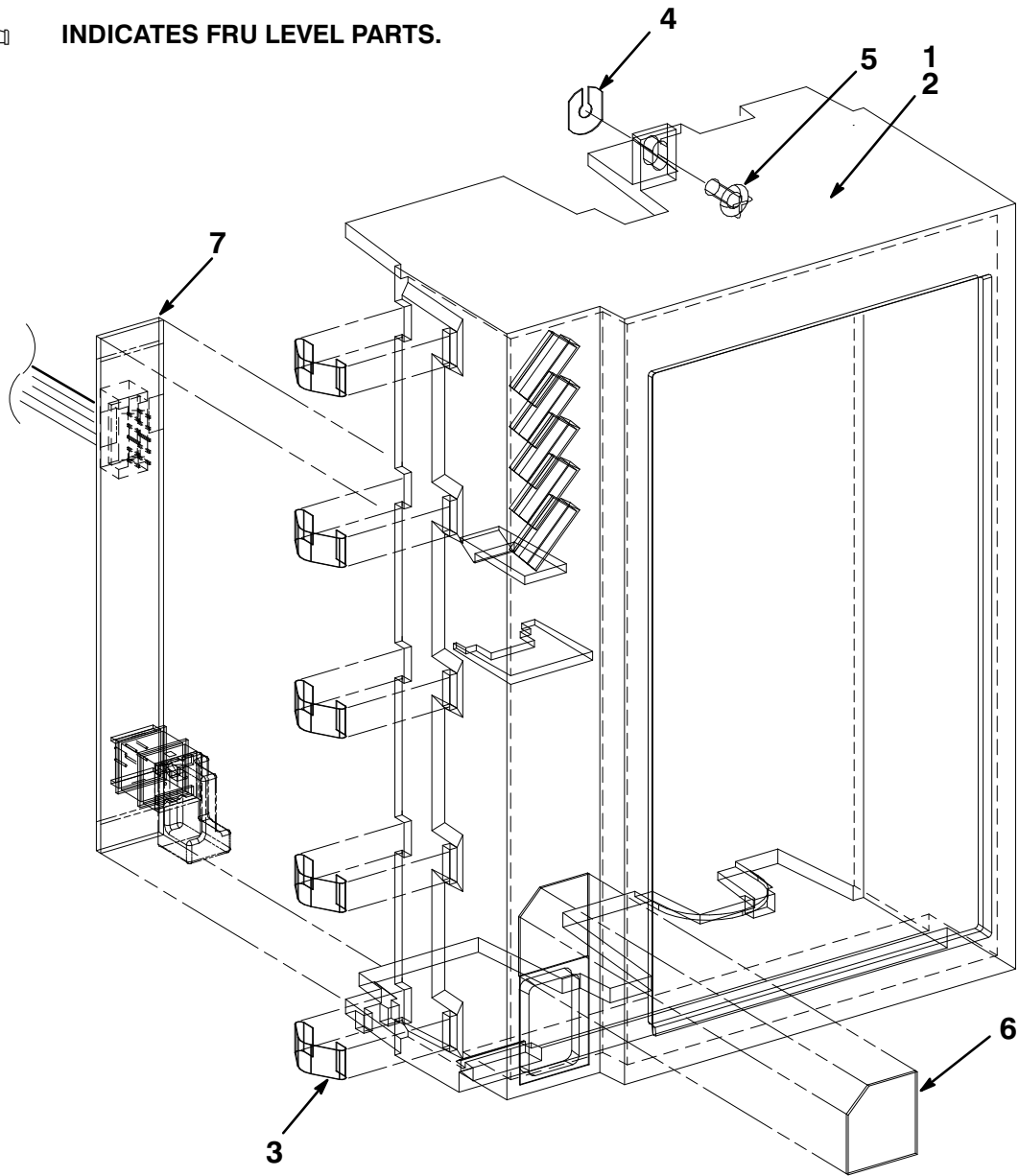

400ST-29-IL

Figure 29. Bezel Assembly, Tape Drive

SCSI DRIVES

INDICATES FRU LEVEL PARTS.

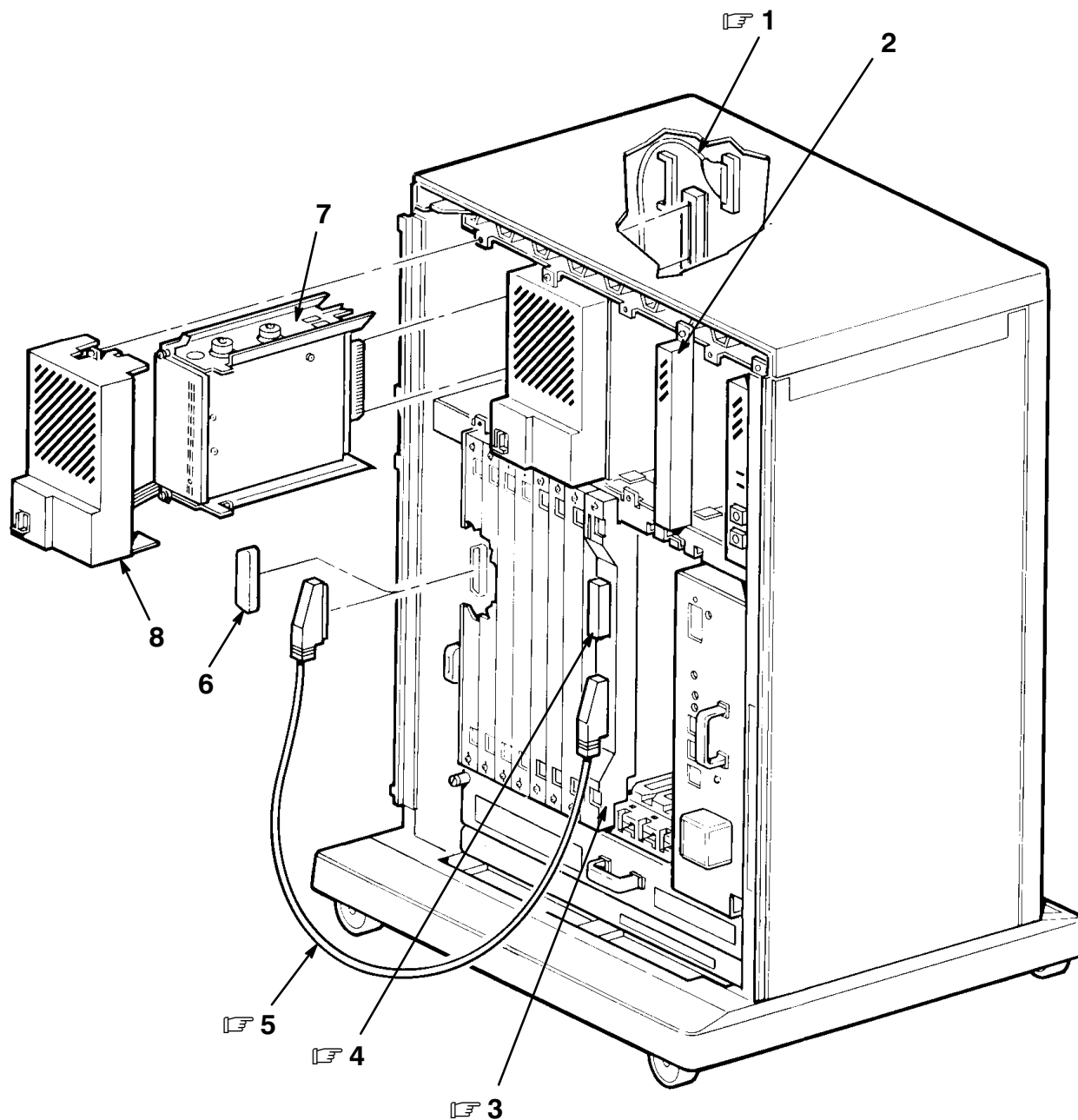

400ST-30-SC

Figure 30. Typical RZ SCSI System Mounting and Cabling (Sheet 1 of 2)

INDICATES FRU LEVEL PARTS.

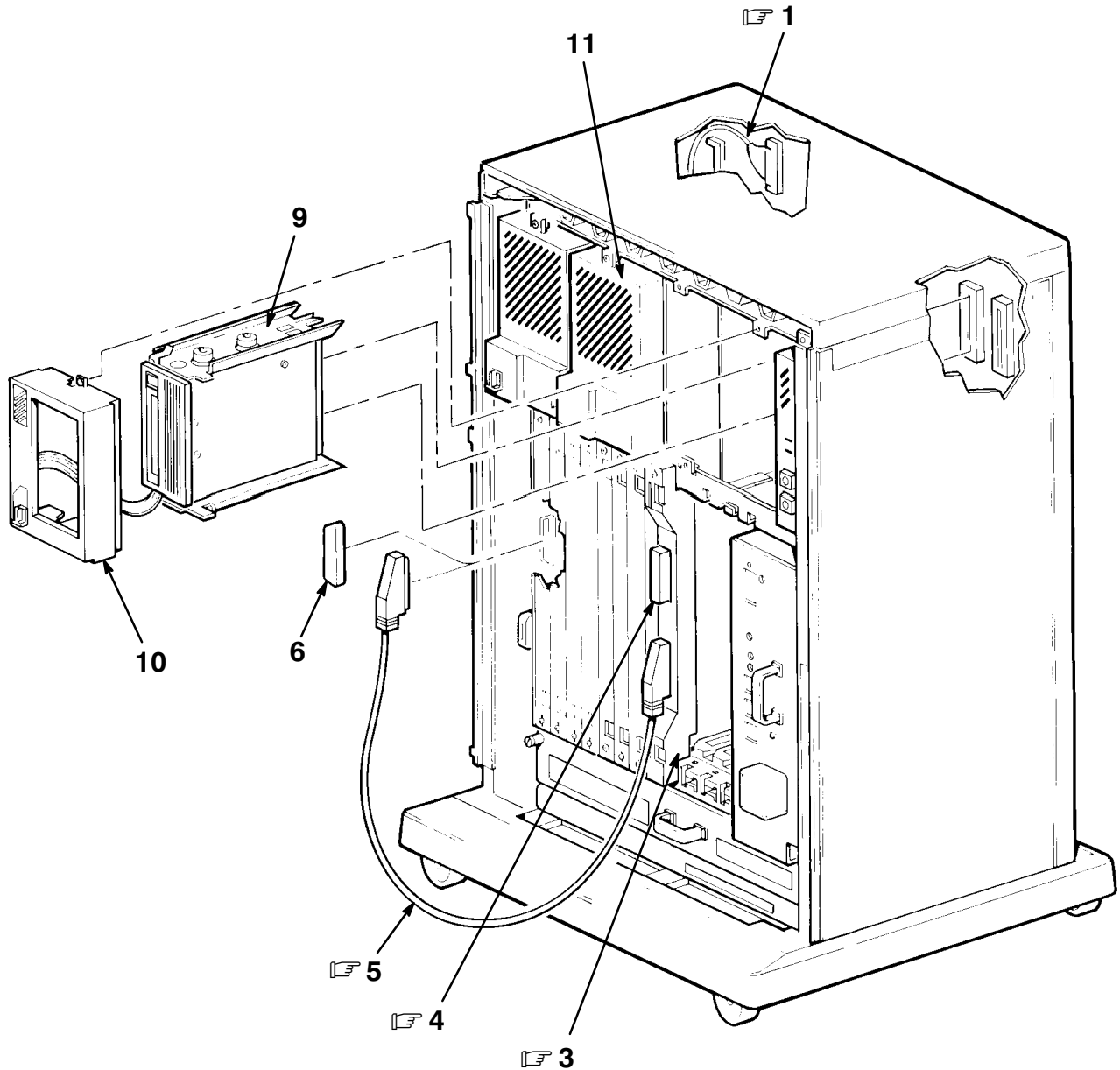

400ST-30A-SC

Figure 30. Typical RZ SCSI System Mounting and Cabling (Sheet 2 of 2)

FIG. & ITEM NO.	DESCRIPTION	DIGITAL PART NO.	ECO CUT-IN	USED ON CODE	REF FIG NO.
30-	TYPICAL SCSI SYSTEM MOUNTING and CABLING				
1	*Cable Assembly, Internal SCSI	70-27459-01			
2	*Bezel Assembly, Filler	70-27414-01			
3	*Module, KZQSA	KZQSA-SA			
4	*Connector, SCSI Term 50 Pos Champ Hsg	12-30552-01			
5	*Cable Assembly, 50 Cond, Molded, Shielded	17-02659-03			
6	*Cover, 50 Pin IDC Connector	12-33377-01			
7	*RZ26L DISK DRIVE ASSEMBLY	RZ26L-AA			41
	*RZ26L DISK DRIVE ASSEMBLY	RZ26L-AF			41
	*RZ28E DISK DRIVE ASSEMBLY	RZ28E-AA			38
	*RZ28E DISK DRIVE ASSEMBLY	RZ28E-AF			38
	*RZ56E DISK DRIVE ASSEMBLY	RZ56E-AA			31
	*RZ56E DISK DRIVE ASSEMBLY	RZ56E-AF			31
	*RZ57E DISK DRIVE ASSEMBLY	RZ57E-AA			32
	*RZ57E DISK DRIVE ASSEMBLY	RZ57E-AF			32
	*RZ58E DISK DRIVE ASSEMBLY	RZ58E-AA			33
	*RZ58E DISK DRIVE ASSEMBLY	RZ58E-AF			33
	*RZ73 DISK DRIVE ASSEMBLY	RZ73E			35
	*RZ74 DISK DRIVE ASSEMBLY	RZ74E			36
	*RZ262 DISK DRIVE ASSEMBLY	RZ262-AA			42
	*RZ262 DISK DRIVE ASSEMBLY	RZ262-AF			42
	*RZ282 DISK DRIVE ASSEMBLY	RZ282-AA			39
	*RZ282 DISK DRIVE ASSEMBLY	RZ282-AF			39
8	*BEZEL ASSEMBLY, DISK DRIVE	70-27049-05			31,32 33,35 36,55
9	*TLZ04 TAPE DRIVE ASSEMBLY	TLZ04-JA			46
	*TLZ04 TAPE DRIVE ASSEMBLY	TLZ04-JF			46
10	*BEZEL ASSEMBLY, TAPE DRIVE (Wide Window)	70-28081-03			58
11	*BEZEL ASSEMBLY, BLANK	70-27049-01			1
	DRIVE ASSEMBLIES (Not Shown) (See Reference Figure Number)				
	*DLTLZ07 TAPE DRIVE ASSEMBLY	DLTLZ07-JA			49
	*DLTLZ07 TAPE DRIVE ASSEMBLY	DLTLZ07-JF			49
	*RRD43 CD-ROM DRIVE ASSEMBLY	RRD43-JA			44
	*RRD43 CD-ROM DRIVE ASSEMBLY	RRD43-JF			44
	*TLZ07 TAPE DRIVE ASSEMBLY	TLZ07-JA			48
	*TLZ07 TAPE DRIVE ASSEMBLY	TLZ07-JF			48
	*TZ86 TAPE DRIVE ASSEMBLY	TZ86-JA			51
	*TZ86 TAPE DRIVE ASSEMBLY	TZ86-JF			51
	*TZ87 TAPE DRIVE ASSEMBLY	TZ87-JA			53
	*TZ87 TAPE DRIVE ASSEMBLY	TZ87-JF			53

THIS PAGE INTENTIONALLY LEFT BLANK

INDICATES FRU LEVEL PARTS.

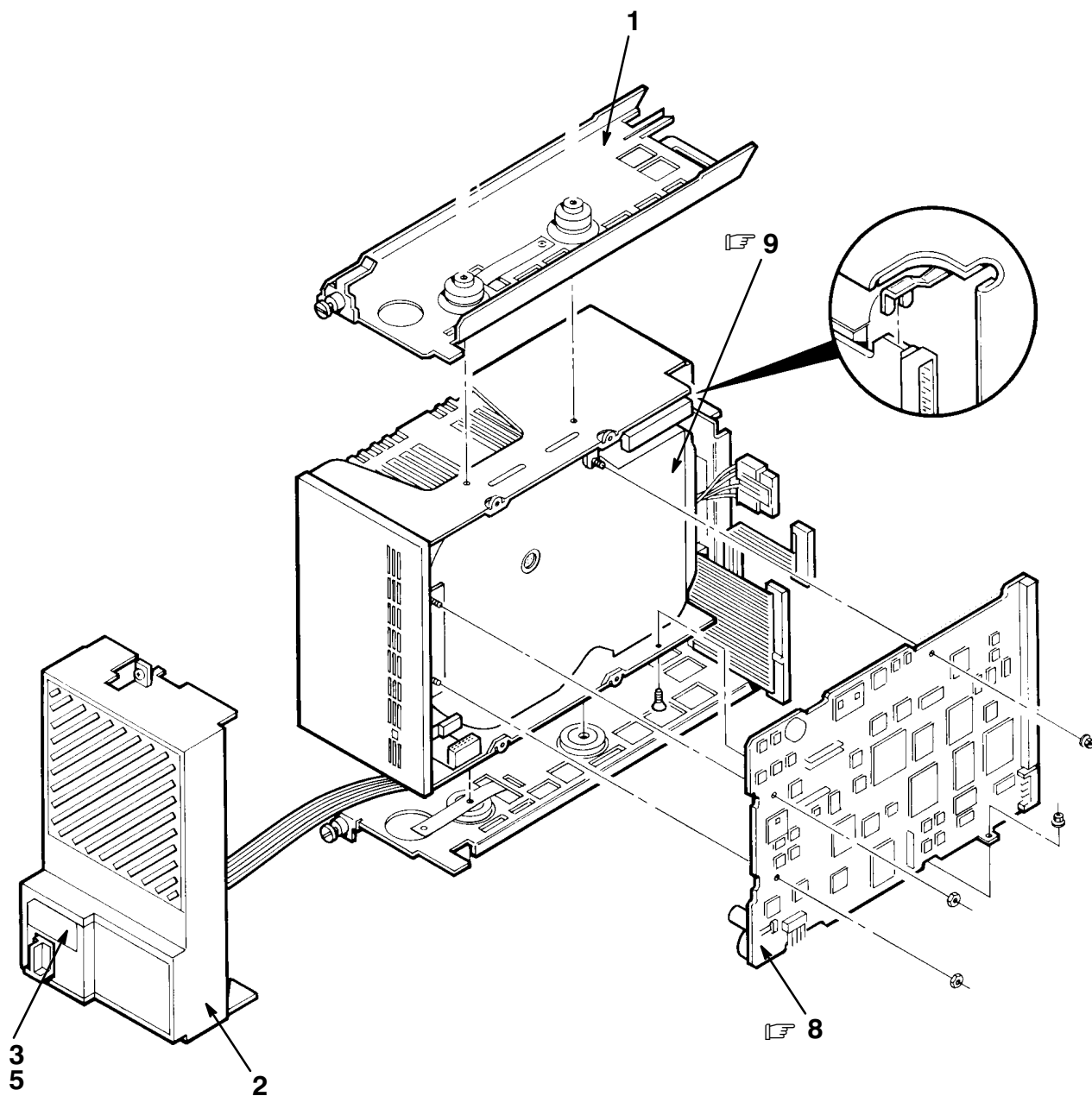

400ST-31-SC

Figure 31. Storage Element, RZ56E

FIG. & ITEM NO.	DESCRIPTION	DIGITAL PART NO. ^c	ECO CUT-IN RZ56E 00001	USED ON CODE	REF FIG NO.
31 –	STORAGE ELEMENT, RZ56E				30
	Code A – Used on RZ56E–AA	RZ56E–AA		A	
	Code B – Used on RZ56E–AF	RZ56E–AF		B	
1	*MOUNTING ASSEMBLY, RZ56 ISE	70–28089–01			34
2	*BEZEL ASSEMBLY, DISK DRIVE	70–27049–05			30,55
3	*Label, “Switch Marker” (deleted)	36–18940–02	00001		
4	*Label, “Bar Code, Integrated Storage” (deleted) (Not Shown)	36–33151–05	00002		
5	*Label, “No. 2 Language Variant”	36–33183–04			
6	*Documentation, “Storage Device Add On Procedure” (Not Shown)	EK–BA44A–IN		B	
7	*Package Assembly (Not Shown)	37–01215–01		B	
8	Module, RZ56 Drive (See Note)	29–27889–01			
9	Disk Assembly, RZ56 (See Note)	29–27890–01			
	Note: Not Part of RZ56E–AA/AF Assembly, Shown For Reference Only.				

INDICATES FRU LEVEL PARTS.

PARTS LIST

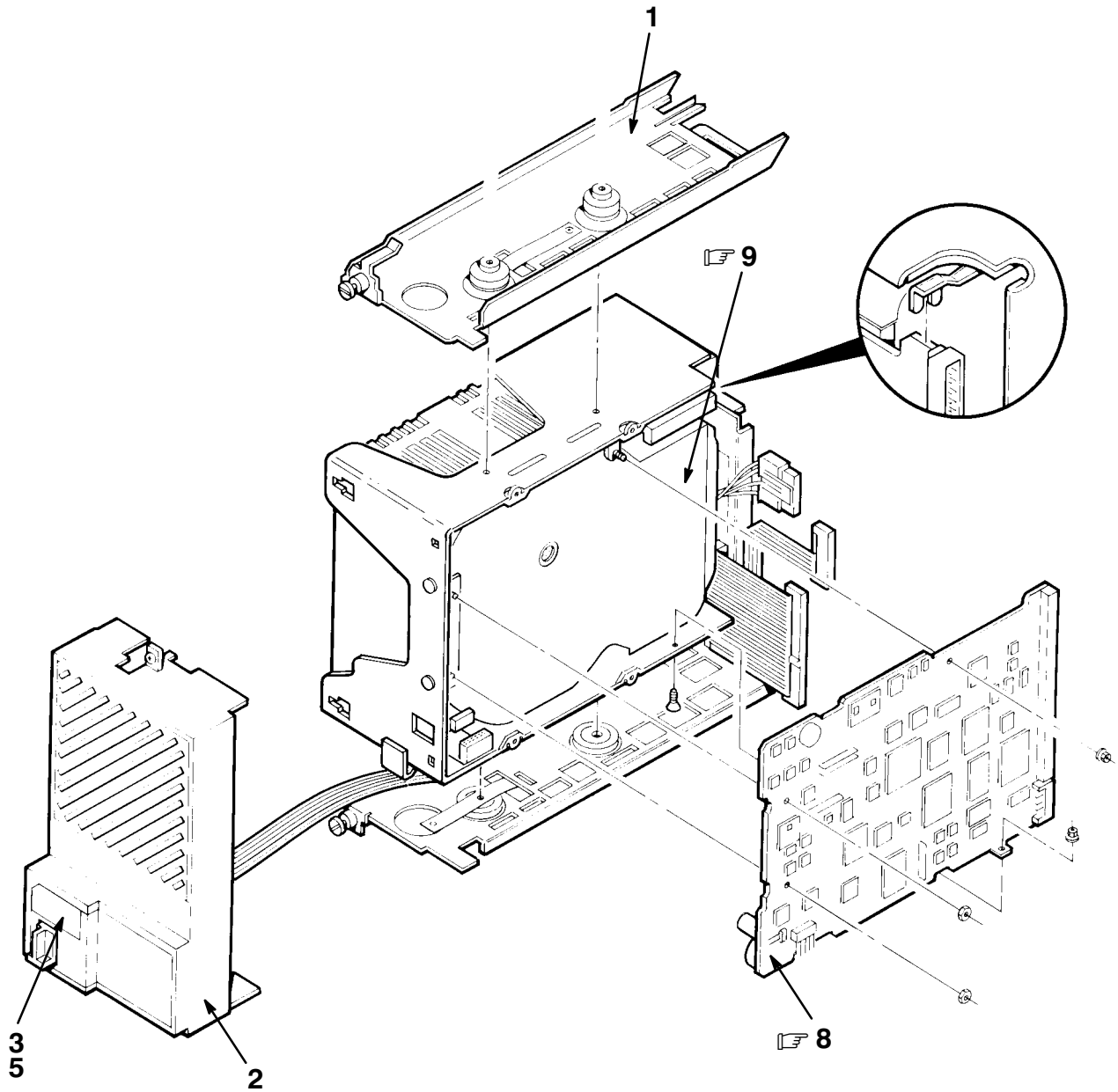

400ST-32-SC

Figure 32. Storage Element, RZ57E

FIG. & ITEM NO.	DESCRIPTION	DIGITAL PART NO. ^c	ECO CUT-IN RZ57E 00000	USED ON CODE	REF FIG NO.
32-	STORAGE ELEMENT, RZ57E				30
	Code A – Used on RZ57E-AA	RZ57E-AA		A	
	Code B – Used on RZ57E-AF	RZ57E-AF		B	
1	*MOUNTING ASSEMBLY, RZ57 ISE	70-28089-02			34
2	*BEZEL ASSEMBLY, DISK DRIVE	70-27049-05			30,55
3	*Label, "Switch Marker" (deleted)	36-18940-02	00001		
4	*Label, "Bar Code, Integrated Storage" (deleted) (Not Shown)	36-33151-05	00002		
5	*Label, "No. 2 Language Variant"	36-33183-04			
6	*Documentation, "Storage Device Add On Procedure" (Not Shown)	EK-BA44A-IN		B	
7	*Package Assembly (Not Shown)	37-01215-01		B	
8	Module, RZ57 Drive (See Note)	29-28159-01			
9	Disk Assembly, RZ57 (See Note)	29-28158-01			
	Note: Not Part of RZ57E-AA/AF Assembly, Shown For Reference Only.				

INDICATES FRU LEVEL PARTS.

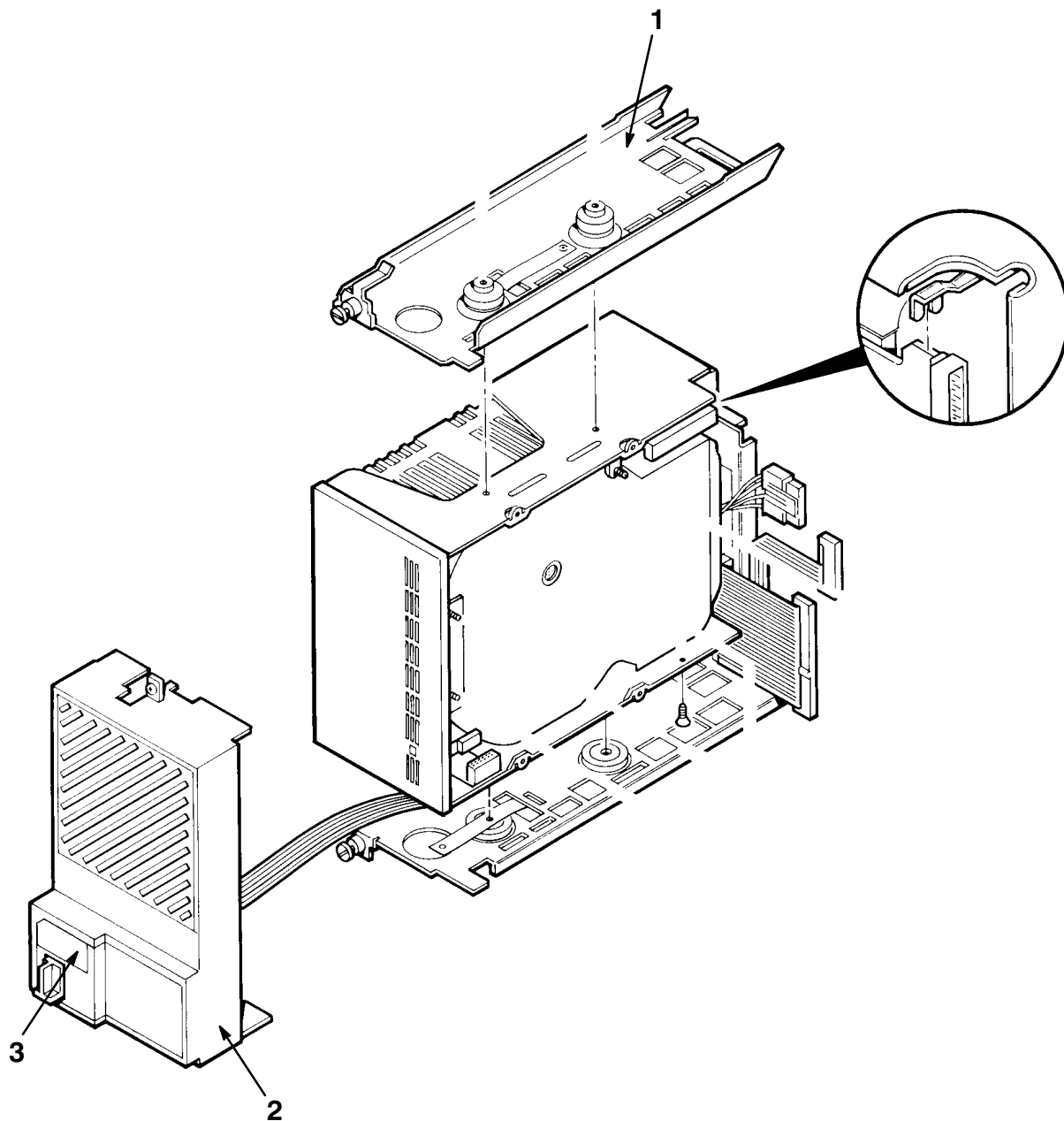

400ST-33-SC

Figure 33. Storage Element, RZ58E

FIG. & ITEM NO.	DESCRIPTION	DIGITAL PART NO. ^A	ECO CUT-IN RZ58E 00000	USED ON CODE	REF FIG NO.
33-	STORAGE ELEMENT, RZ58E				30
	Code A - Used on RZ58E-AA	RZ58E-AA		A	
	Code B - Used on RZ58E-AF	RZ58E-AF		B	
1	*MOUNTING ASSEMBLY, RZ58 ISE	70-28089-03			34
2	*BEZEL ASSEMBLY, DISK DRIVE	70-27049-05			30,36,55
3	*Label, "No. 2 Language Variant"	36-33183-04			
4	*Documentation, "Storage Device Add On Procedure" (Not Shown)	EK-BA44A-IN		B	
5	*Package Assembly (Not Shown)	37-01215-01		B	

☞ ☞ INDICATES FRU LEVEL PARTS.

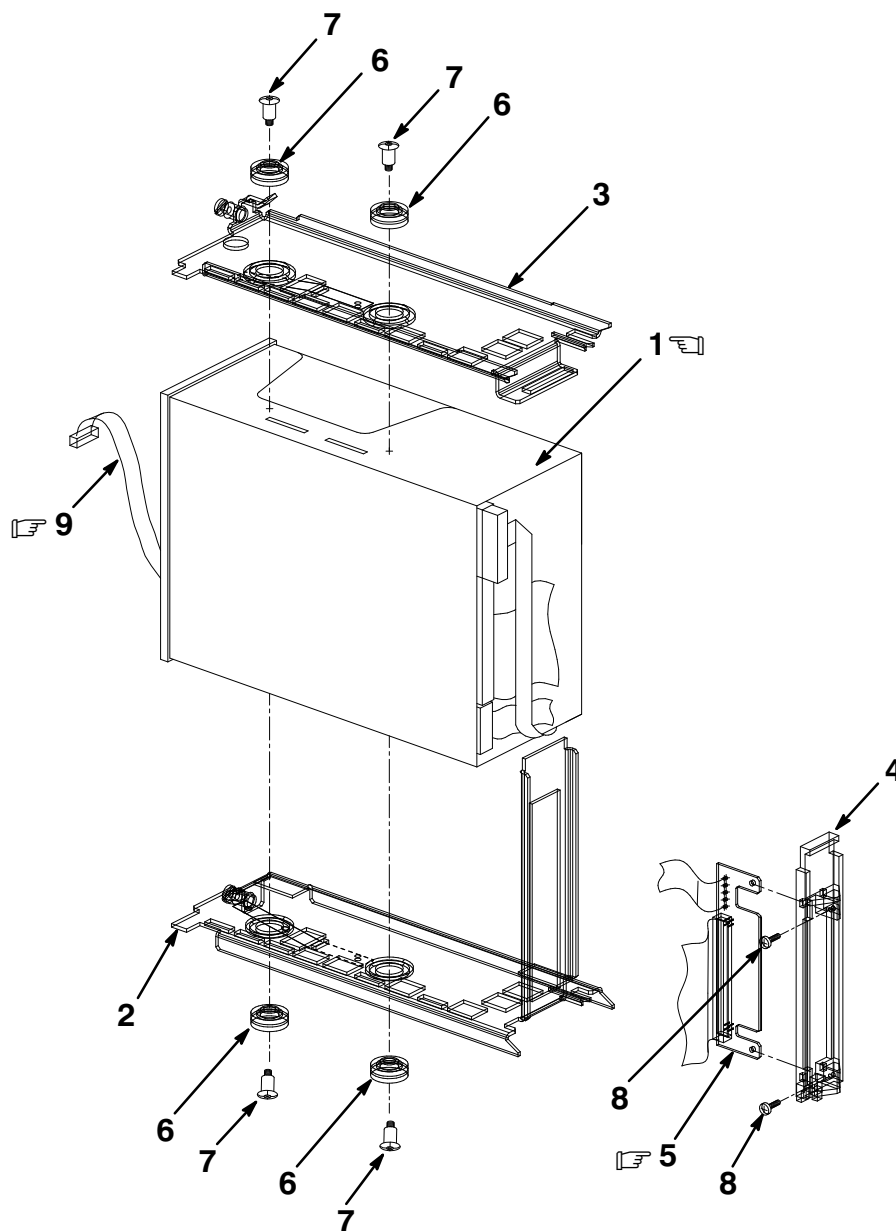

400ST-34-IL

Figure 34. Mounting Assembly, RZ56/RZ57/RZ58 ISE

FIG. & ITEM NO.	DESCRIPTION	DIGITAL PART NO. ^B	ECO CUT-IN 70-28089 00000	USED ON CODE	REF FIG NO.
34-	MOUNTING ASSEMBLY, RZ56 ISE	70-28089-01		A	31
	MOUNTING ASSEMBLY, RZ57 ISE	70-28089-02		B	32
	MOUNTING ASSEMBLY, RZ58 ISE (added)	70-28089-03	00001	C	33
☞ 1	*Disk Drive Assembly	RZ56-E		A	
☞	*Disk Drive Assembly	RZ57-E		B	
☞	*Disk Drive Assembly (added)	RZ58-E	00001	C	
2	*Bracket Assembly, Bottom Drive	70-28076-01			
3	*Bracket, Top SCSI	74-41144-01			
4	*Bracket, Paddle Board	74-38830-01			
☞ 5	*Module, SCSI Interface Card	54-20136-01			
6	*Isolator, Shock Grommet	12-32626-04			
7	*Screw, Shoulder No. 6-32	12-34462-02			
8	*Screw, Phi Pan Hd No. 4-40 x 1/4	90-09315-01			
☞ 9	*Cable Assembly, 10 Cond.	17-02887-01			

INDICATES FRU LEVEL PARTS.

PARTS LIST

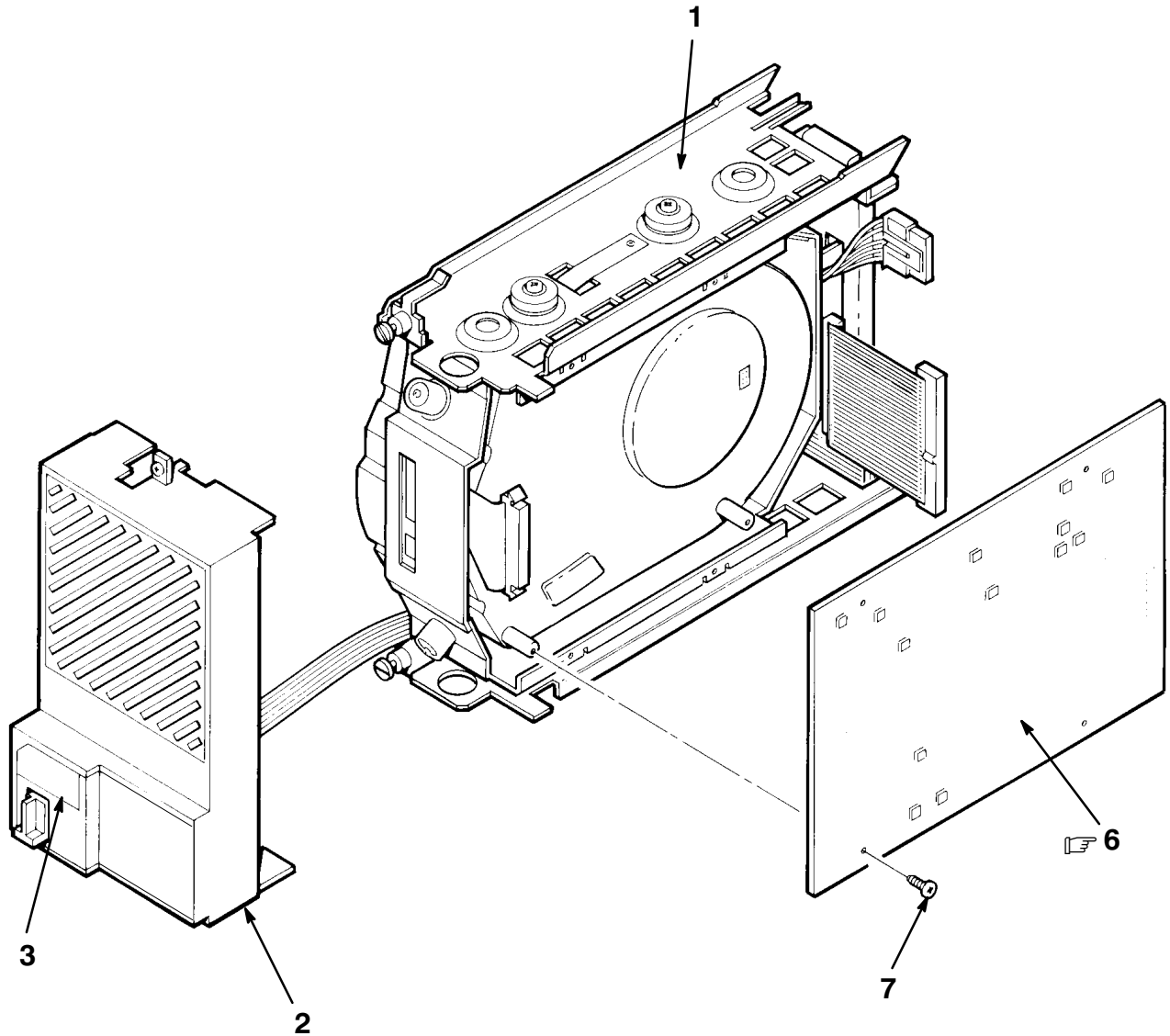

400ST-35-SC

Figure 35. Storage Element, RZ73E

FIG. & ITEM NO.	DESCRIPTION	DIGITAL PART NO. ^H	ECO CUT-IN RF73E 00006	USED ON CODE	REF FIG NO.
35-	STORAGE ELEMENT, RZ73E	RZ73E			30
1	*MOUNTING ASSEMBLY, RZ73 ISE	70-28089-04			37
2	*BEZEL ASSEMBLY, 5 1/4 INCH DISK DRIVE	70-27049-05			27,30
3	*Label, "No. 2 Language Variant" (See Note 1)	36-33183-04			55
4	*Documentation, "Storage Device Add On Procedure" (Not Shown)	EK-BA44A-IN			
5	*Package Assembly (Not Shown)	37-01215-01			
6	Module, RZ73 Drive (See Notes 2 and 3)	54-19110-XX			
7	Screw, Mach Phi Pan Hd No. 4-40 x 3/8 (See Note 3)	90-06011-01			
	Note 1: Language Specific Used In Place Of 01				
	Note 2: XX = Order Latest Version.				
	Note 3: Not Part of RZ73E Assembly, Shown For Reference Only.				

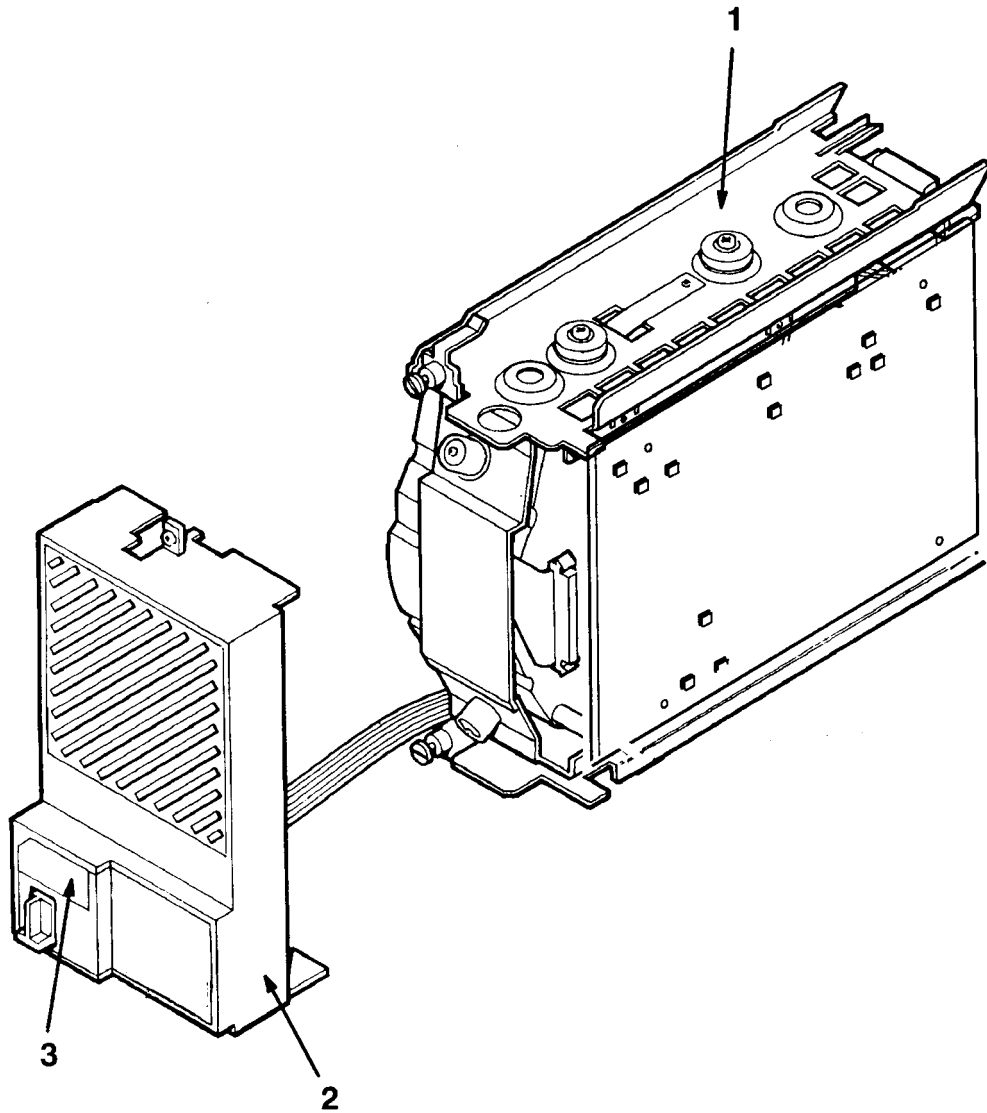

400ST-36-SC

Figure 36. Storage Element, RZ74E

FIG. & ITEM NO.	DESCRIPTION	DIGITAL PART NO. ^A	ECO CUT-IN RF74E 00000	USED ON CODE	REF FIG NO.
36-	☞ STORAGE ELEMENT, RZ74E	RZ74E			1
1	*MOUNTING ASSEMBLY, RZ74 ISE	70-28089-05			37
2	*BEZEL ASSEMBLY, 5 1/4 INCH DISK DRIVE	70-27049-05			27,30
3	*Label, "No. 2 Language Variant" (See Note 1)	36-33183-04			33,55
4	*Documentation, "Storage Device Add On Procedure" (Not Shown)	EK-BA44A-IN			
5	*Package Assembly (Not Shown)	37-01215-01			
	<p>Note 1: Language Specific Used In Place Of 01.</p>				

  INDICATES FRU LEVEL PARTS.

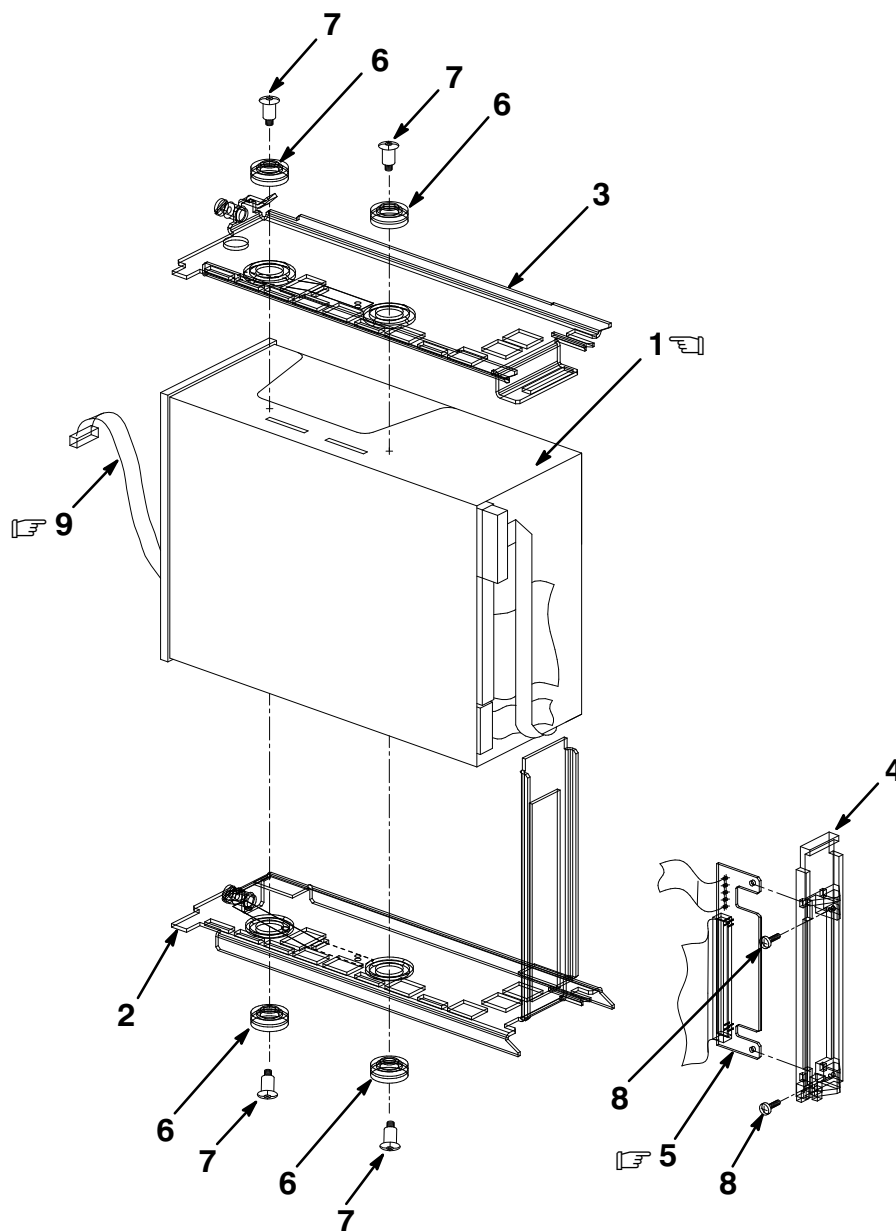

400ST-37-IL

Figure 37. Mounting Assembly, RZ73/RZ74 ISE

FIG. & ITEM NO.	DESCRIPTION	DIGITAL PART NO. ^B	ECO CUT-IN 70-28089 00000	USED ON CODE	REF FIG NO.
37-	MOUNTING ASSEMBLY, RZ73 ISE MOUNTING ASSEMBLY, RZ74 ISE	70-28089-04 70-28089-05		A B	35 36
☞ 1	*Disk Drive Assembly *Disk Drive Assembly	RZ73-E RZ74-E		A B	
2	*Bracket Assembly, Bottom Drive	70-27412-01			
3	*Bracket, Top SCSI	74-38828-01			
4	*Bracket, Paddle Board	74-38830-01			
☞ 5	*Module, SCSI Interface Card	54-20136-01			
6	*Isolator, Shock Grommet	12-32626-04			
7	*Screw, Shoulder No. 6-32	12-34462-01			
8	*Screw, Phi Pan Hd No. 4-40 x 1/4	90-09315-01			
☞ 9	*Cable Assembly, 06 Cond.	17-03498-01			

FIG. & ITEM NO.	DESCRIPTION	DIGITAL ^A PART NO.	ECO CUT-IN RZ28E 00000	USED ON CODE	REF FIG NO.
38-	STORAGE ELEMENT, RZ28E (See Note)				
	Code A – Used on RZ28E-AA	RZ28E-AA		A	30
	Code B – Used on RZ28E-AF	RZ28E-AF		B	30
1	*DRIVE ASSEMBLY, BA400, SCSI	70-22863-03			40
2	*BEZEL ASSEMBLY, 3 1/2 INCH DSSI DISK DRIVE	70-29478-02			56
3	*Documentation, "Storage Device(s) Add On Procedure" (Not Shown)	EK-BA44A-IN		B	
4	*Package Assembly (Not Shown)	37-01215-01		B	
	Note: Supported Only If HSD05-JA/JF Is Installed In The Enclosure.				

  INDICATES FRU LEVEL PARTS.

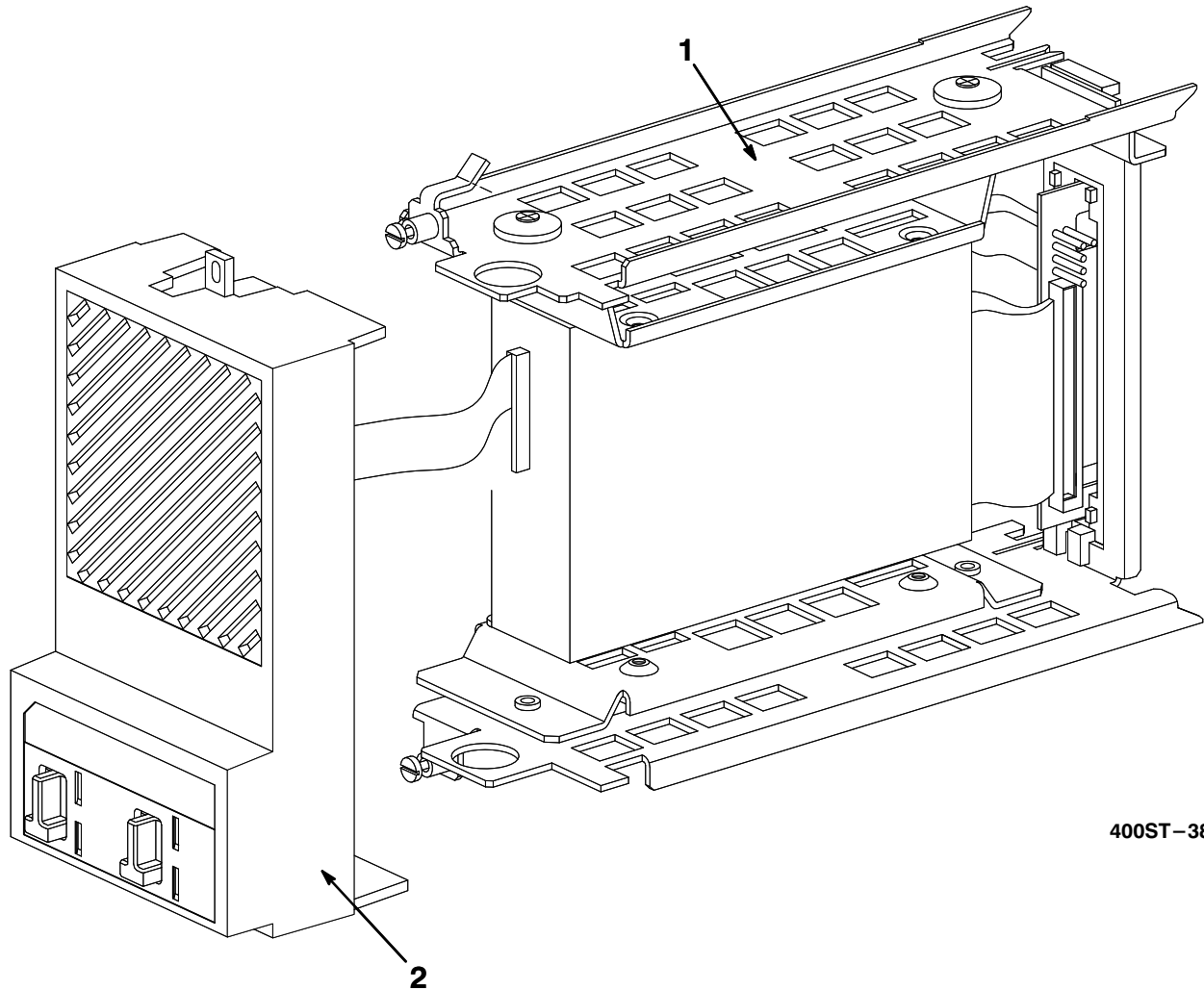

400ST-38-IL

Figure 38. Storage Element, RZ28E

FIG. & ITEM NO.	DESCRIPTION	DIGITAL ^A PART NO.	ECO CUT-IN RZ282 00000	USED ON CODE	REF FIG NO.
39-	STORAGE ELEMENT, RZ282 DUAL (See Note)				
	Code A – Used on RZ282-AA	RZ282-AA		A	30
	Code B – Used on RZ282-AF	RZ282-AF		B	30
1	*DRIVE ASSEMBLY, BA400, SCSI	70-22863-04			40
2	*BEZEL ASSEMBLY, 3 1/2 INCH DSSI DISK DRIVE	70-29478-02			56
3	*Documentation, "Storage Device(s) Add On Procedure" (Not Shown)	EK-BA44A-IN		B	
4	*Package Assembly (Not Shown)	37-01215-01		B	
	Note: Supported Only If HSD05-JA/JF Is Installed In The Enclosure.				

  INDICATES FRU LEVEL PARTS.

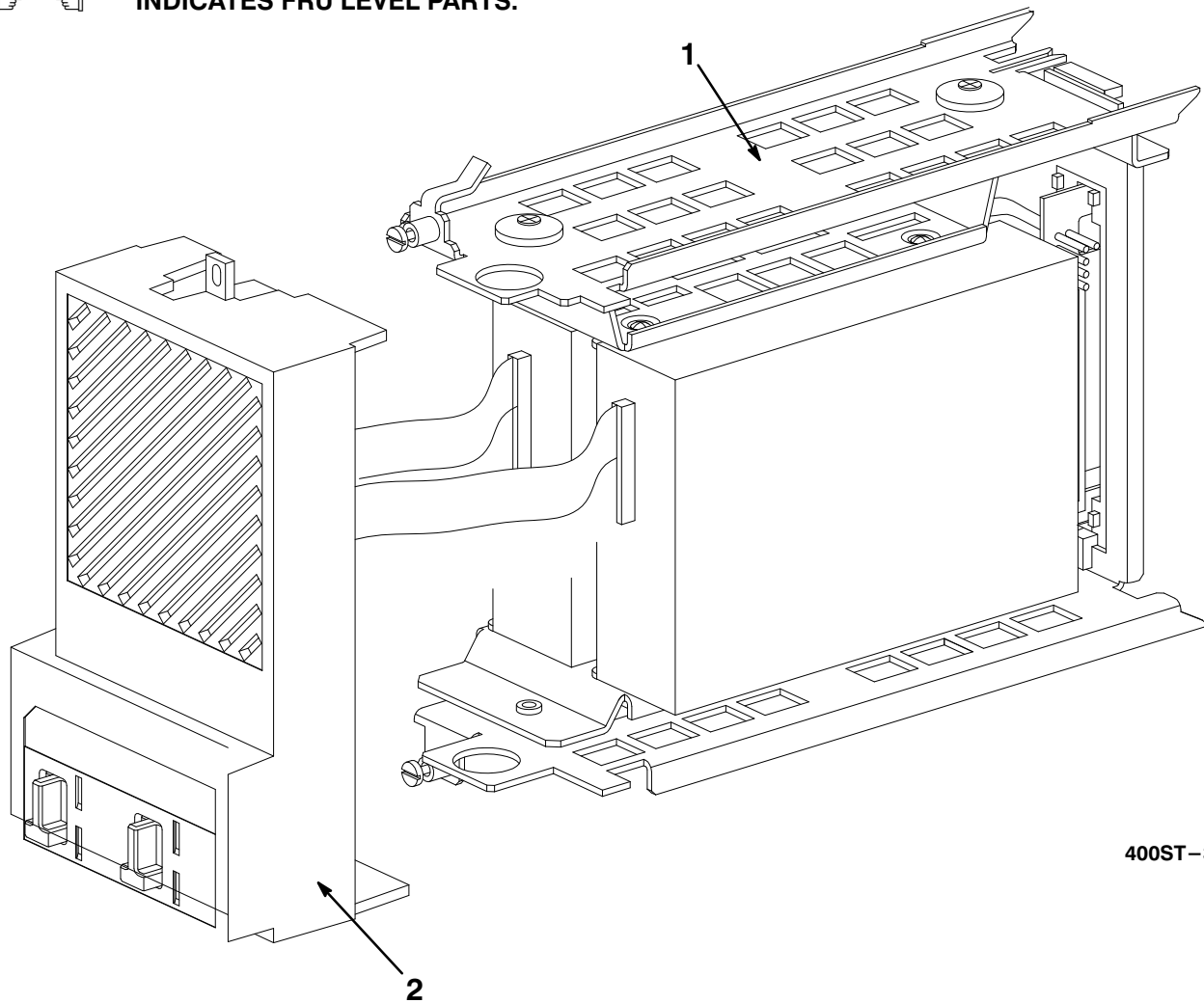

400ST-39-IL

Figure 39. Storage Element, RZ282 Dual

  INDICATES FRU LEVEL PARTS.

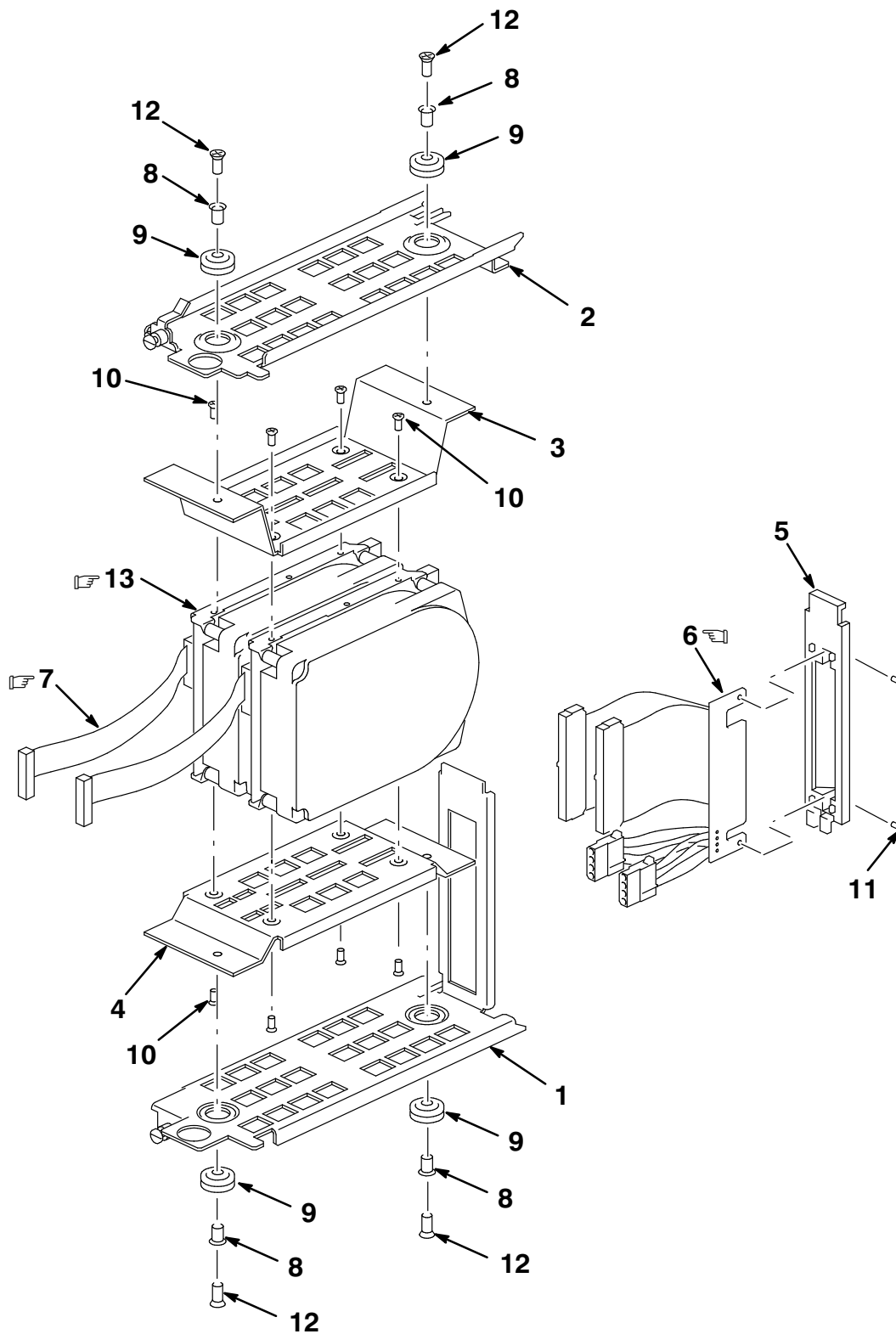

400ST-40-IL

Figure 40. Drive Assembly, BA400 SCSI

FIG. & ITEM NO.	DESCRIPTION	DIGITAL PART NO. ^A	ECO CUT-IN 7022863 00000	USED ON CODE	REF FIG NO.
40-	DRIVE ASSEMBLY, BA400, SCSI (RZ28)	70-22863-03			38
	DRIVE ASSEMBLY, BA400, SCSI (RZ282)	70-22863-04			39
1	*Bracket Assembly, Bottom Drive	74-48767-01			
2	*Bracket Assembly, Top Drive	74-48768-01			
3	*Plate, Top Bracket Adapter	74-44233-01			
4	*Plate, Bottom Bracket Adapter	74-44234-01			
5	*Bracket, Paddle Module	74-38830-01			
☞ 6	*Module, SCSI Interface	54-23320-02			
☞ 7	*Cable Assembly, RFP 7 in. Female Flat (See Note)	17-03428-01			
8	*Isolator, Shock Ferrule	12-32626-03			
9	*Isolator, Shock Grommet	12-32626-04			
10	*Screw, Sems Phi Hd No. 6-32 x 1/4	90-10174-00			
11	*Screw, Phi Pan Hd No. 4-40 x 1/4	90-09315-01			
12	*Screw, Machine Flat Hd No. 6-32 x 5/8	90-06025-02			
☞ 13	*Storage Element, RZ28E (See Note)	RZ28E			
	Note: Use Quantity Of One For -03 Variation.				

FIG. & ITEM NO.	DESCRIPTION	DIGITAL ^A PART NO.	ECO CUT-IN RZ26L 00000	USED ON CODE	REF FIG NO.
41-	STORAGE ELEMENT, RZ26L (See Note)				
	Code A – Used on RZ26L-AA	RZ26L-AA		A	30
	Code B – Used on RZ26L-AF	RZ26L-AF		B	30
1	*DRIVE ASSEMBLY, BA400, SCSI	70-22863-01			43
2	*BEZEL ASSEMBLY, 3 1/2 INCH DSSI DISK DRIVE	70-29478-02			56
3	*Documentation, "Storage Device(s) Add On Procedure" (Not Shown)	EK-BA44A-IN		B	
4	*Package Assembly (Not Shown)	37-01215-01		B	
	Note: Supported Only If HSD05-JA/JF Is Installed In The Enclosure.				

  INDICATES FRU LEVEL PARTS.

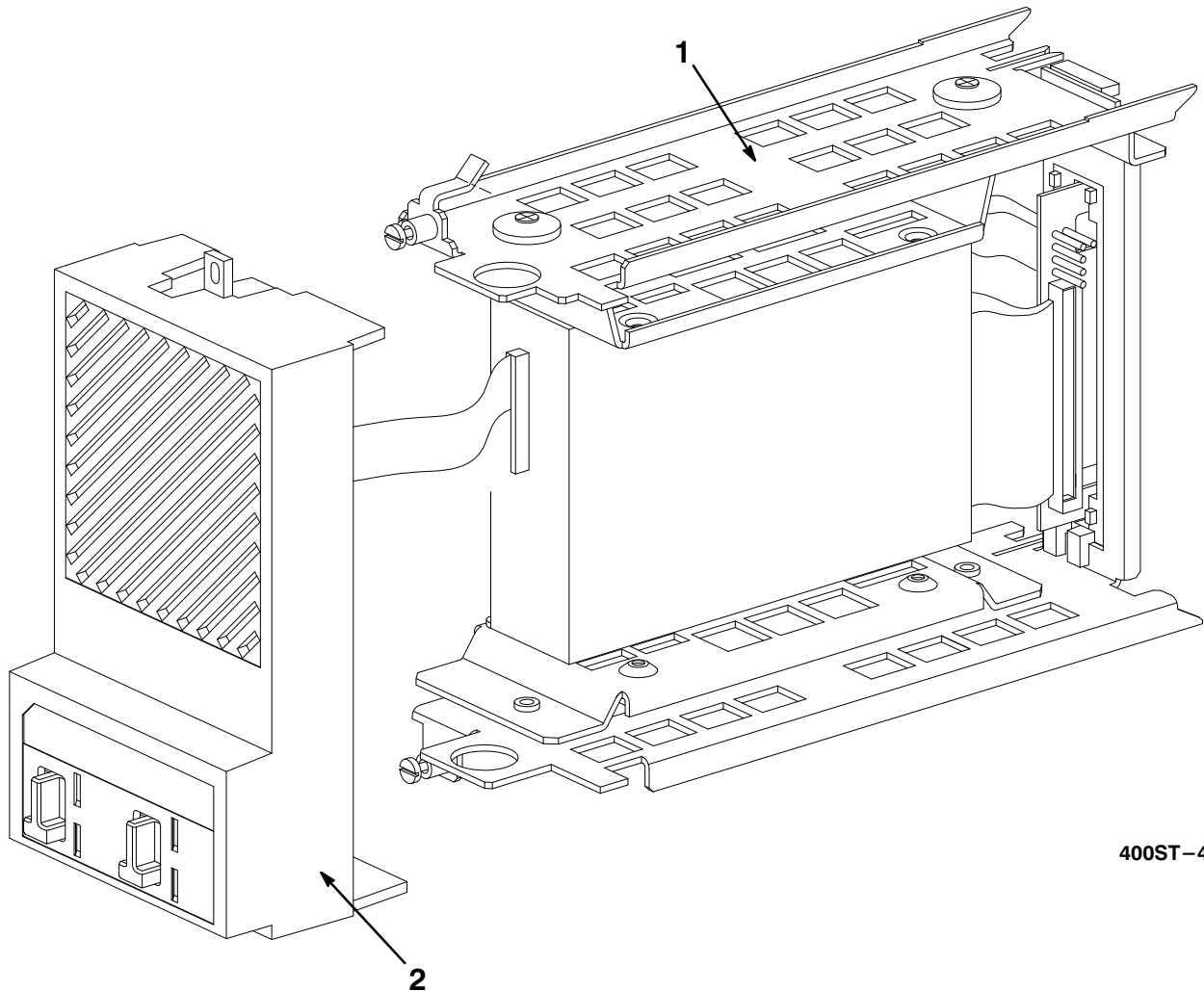

400ST-41-IL

Figure 41. Storage Element, RZ26L

FIG. & ITEM NO.	DESCRIPTION	DIGITAL ^A PART NO.	ECO CUT-IN RZ262 00000	USED ON CODE	REF FIG NO.
42-	STORAGE ELEMENT, RZ262 DUAL (See Note)				
	Code A – Used on RZ262-AA	RZ262-AA		A	30
	Code B – Used on RZ262-AF	RZ262-AF		B	30
1	*DRIVE ASSEMBLY, BA400, SCSI	70-22863-02			43
2	*BEZEL ASSEMBLY, 3 1/2 INCH DSSI DISK DRIVE	70-29478-02			56
3	*Documentation, "Storage Device(s) Add On Procedure" (Not Shown)	EK-BA44A-IN		B	
4	*Package Assembly (Not Shown)	37-01215-01		B	
	Note: Supported Only If HSD05-JA/JF Is Installed In The Enclosure.				

  INDICATES FRU LEVEL PARTS.

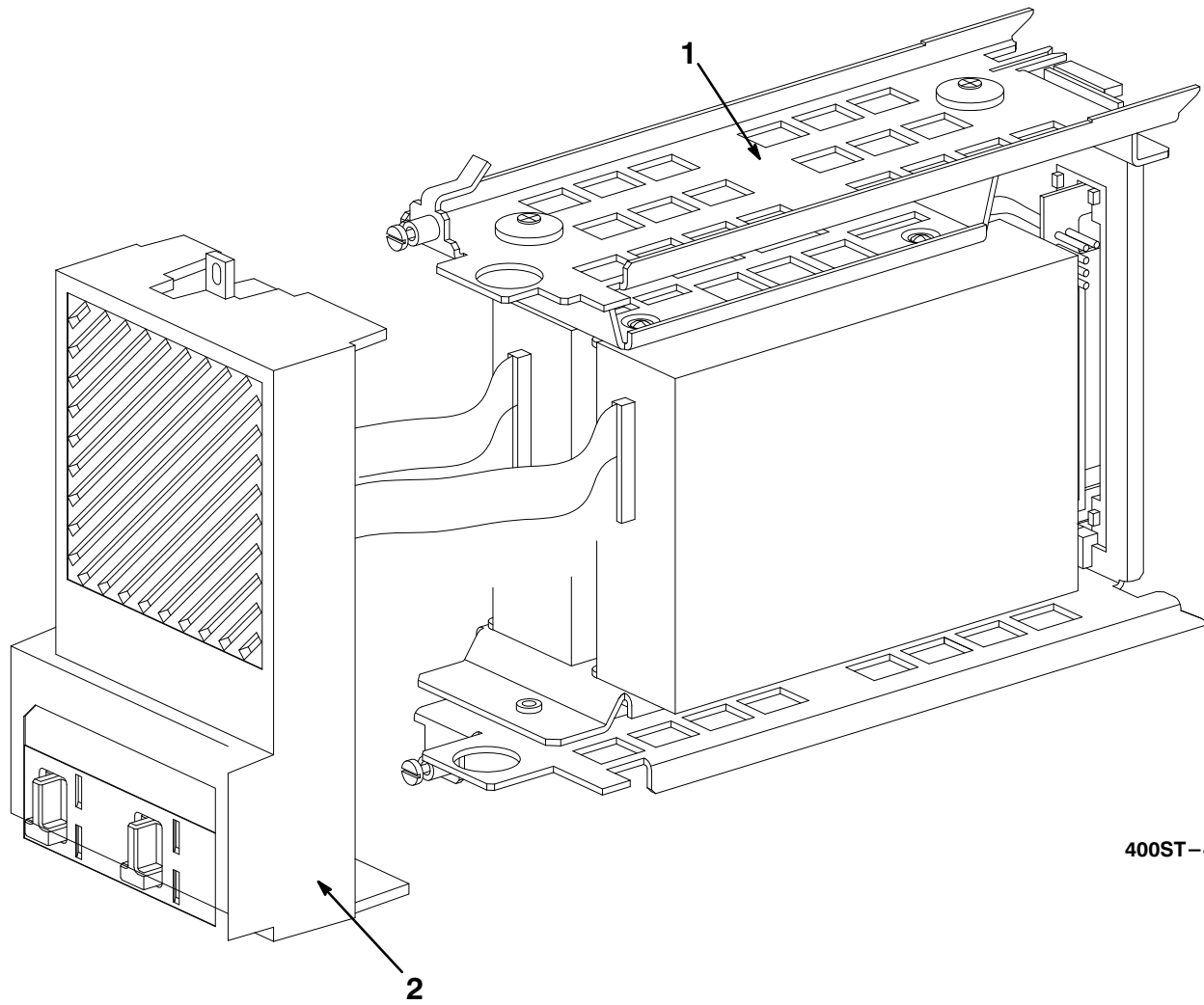
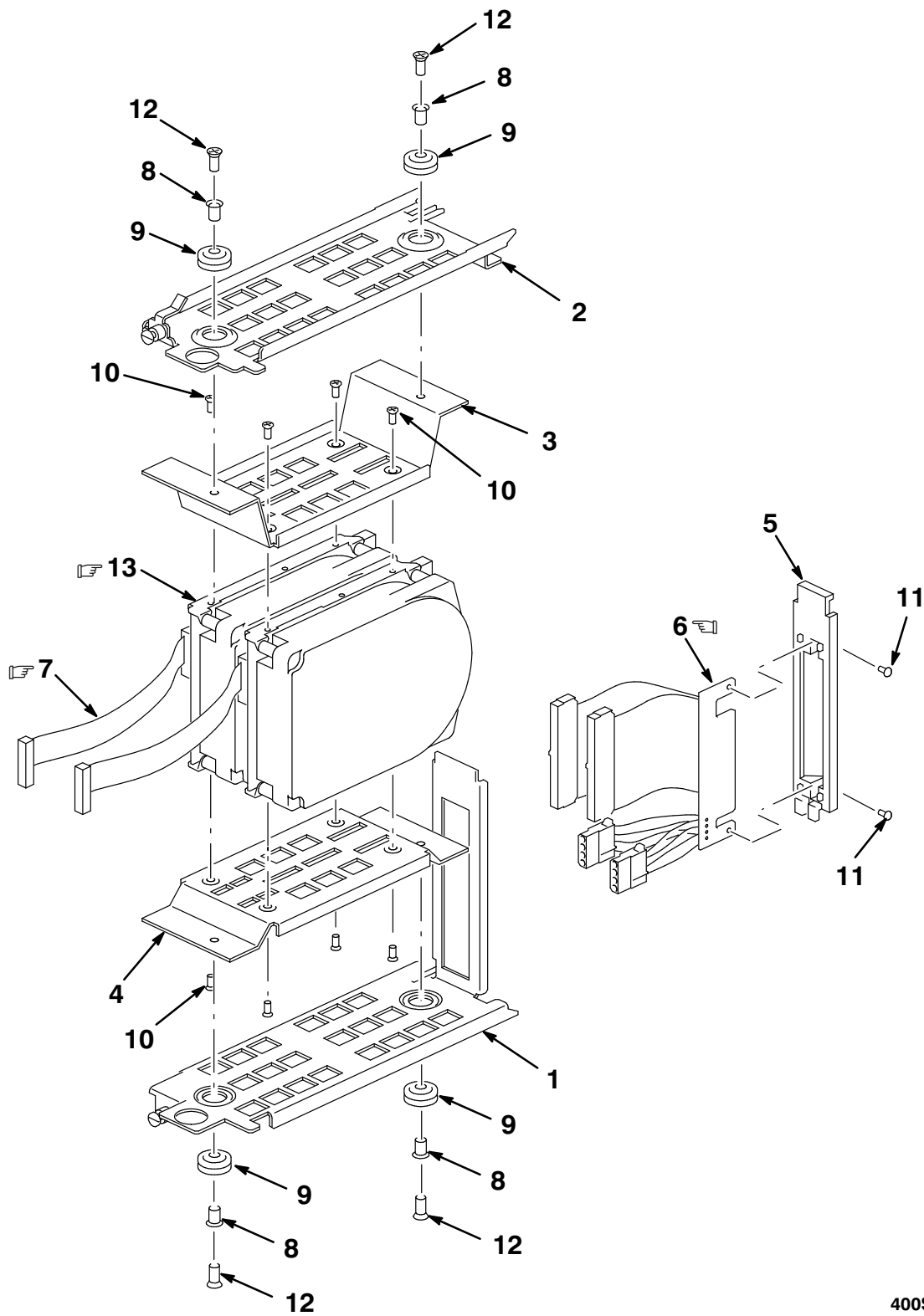

Figure 42. Storage Element, RZ262 Dual

 INDICATES FRU LEVEL PARTS.



400ST-43-IL

Figure 43. Drive Assembly, BA400 SCSI

FIG. & ITEM NO.	DESCRIPTION	DIGITAL PART NO. ^A	ECO CUT-IN 7022863 00000	USED ON CODE	REF FIG NO.
43-	DRIVE ASSEMBLY, BA400, SCSI (RZ26L) DRIVE ASSEMBLY, BA400, SCSI (RZ262)	70-22863-01 70-22863-02			41 42
1	*Bracket Assembly, Bottom Drive	74-48767-01			
2	*Bracket Assembly, Top Drive	74-48768-01			
3	*Plate, Top Bracket Adapter	74-44233-01			
4	*Plate, Bottom Bracket Adapter	74-44234-01			
5	*Bracket, Paddle Module	74-38830-01			
☞ 6	*Module, SCSI Interface	54-23320-02			
☞ 7	*Cable Assembly, RFP 7 in. Female Flat (See Note)	17-03428-01			
8	*Isolator, Shock Ferrule	12-32626-03			
9	*Isolator, Shock Grommet	12-32626-04			
10	*Screw, Sems Phi Hd No. 6-32 x 1/4	90-10174-00			
11	*Screw, Phi Pan Hd No. 4-40 x 1/4	90-09315-01			
12	*Screw, Machine Flat Hd No. 6-32 x 5/8	90-06025-02			
☞ 13	*Storage Element, RZ26L (See Note) NOTE: Use Quantity Of One For 70-22863-01.	RZ26L			

☞ ☞ INDICATES FRU LEVEL PARTS.

PARTS LIST

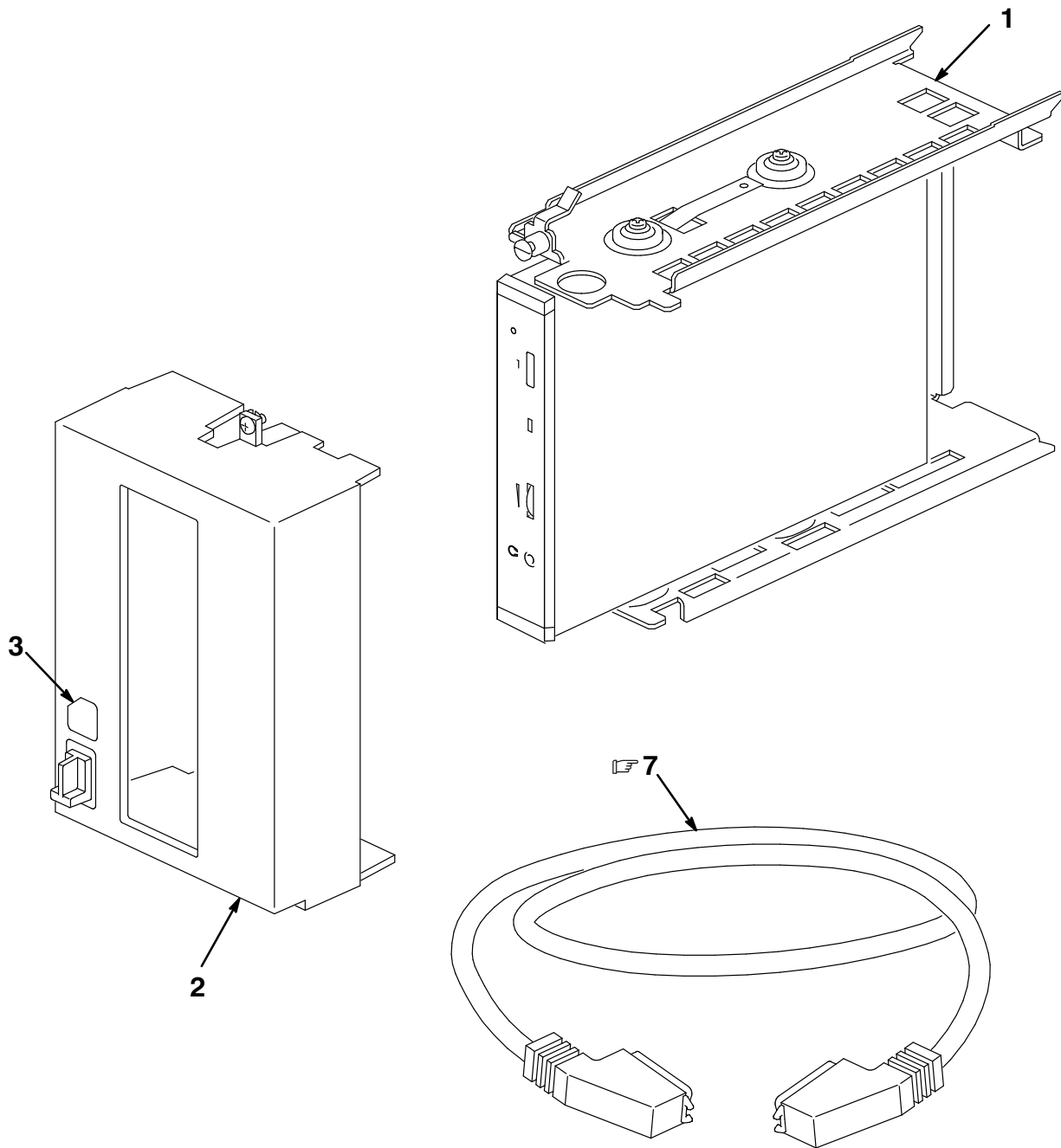

400ST-44-IL

Figure 44. Storage Element, RRD43

FIG. & ITEM NO.	DESCRIPTION	DIGITAL PART NO. ^A	ECO CUT-IN RRD43 00000	USED ON CODE	REF FIG NO.
44-	STORAGE ELEMENT, RRD43				
	Code A – Used on RRD43–JA	RRD43–JA		A	30
	Code B – Used on RRD43–JF	RRD43–JF		B	30
1	*MOUNTING ASSEMBLY, RRD43 ISE	70–22864–01			45
2	*BEZEL ASSEMBLY, BA400, RRD43	70–22865–02			57
3	*Label, “Bus ID, LV”	36–33181–02			
4	*Documentation, “RRD43 CD–ROM Disk Drive Information” (Not Shown)	EK–RRDDD–IN			
5	*Documentation, “Storage Device(s) Add On Procedures” (Not Shown)	EK–BA44A–IN		B	
6	*Package Assembly (Not Shown)	37–01215–04		B	
7	*Cable Assembly, 50 Cond, Molded, Shielded (See Note)	17–02659–03			
	NOTE: Item 7 Is Required When Connecting To An Embedded KZQSA.				

☞ ☞ INDICATES FRU LEVEL PARTS.

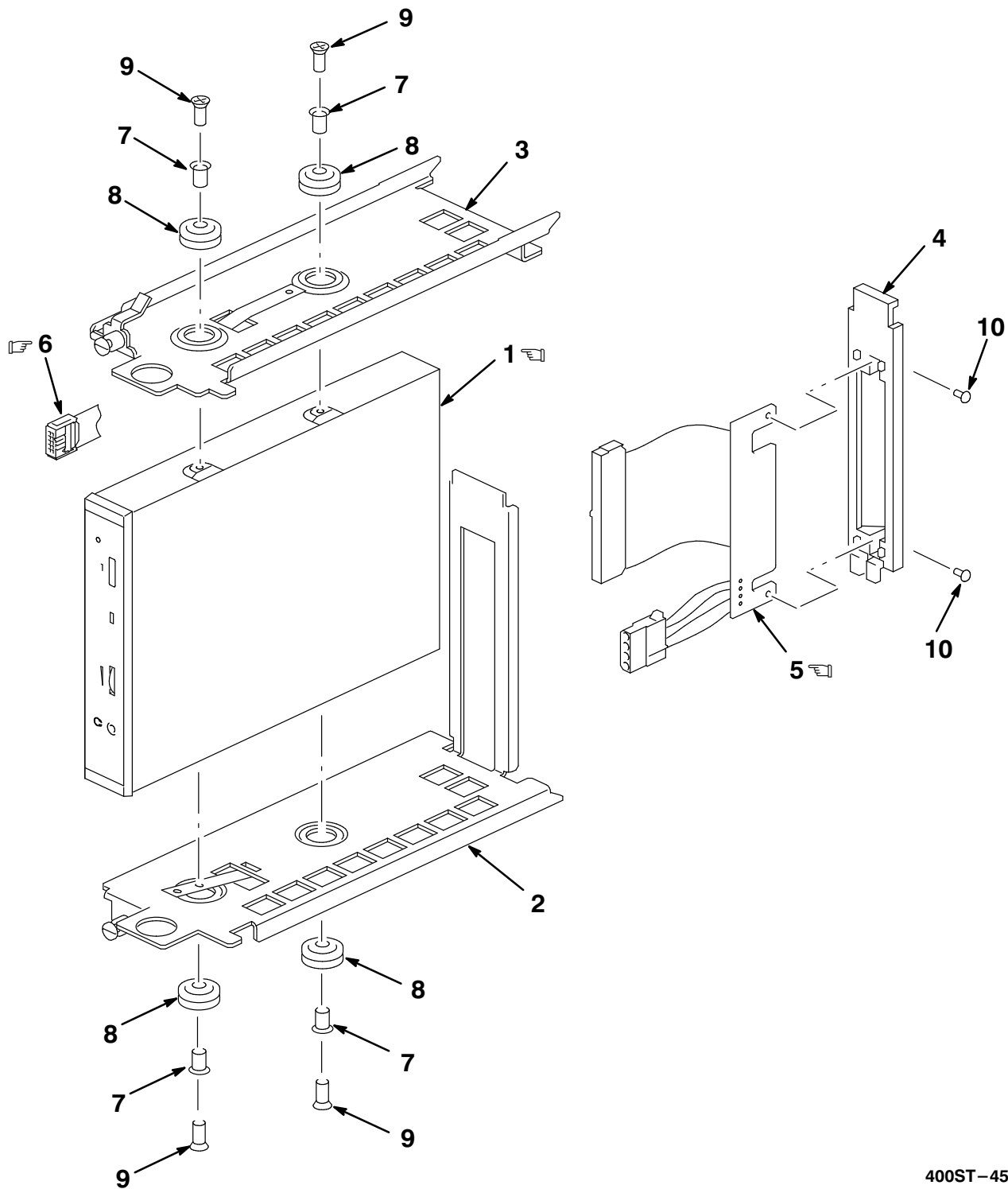

400ST-45-IL

Figure 45. Mounting Assembly, RRD43 ISE

FIG. & ITEM NO.	DESCRIPTION	DIGITAL PART NO. ^A	ECO CUT-IN 7022864 00000	USED ON CODE	REF FIG NO.
45-	MOUNTING ASSEMBLY, RRD43 ISE	70-22864-01			44
☞ 1	*CD-ROM Drive Assembly, 1 Inch High Dual Speed, 5 1/4 Inch SCSI, 600 MB	RRD43-AB			
2	*Bracket Assembly, Bottom	74-48671-01			
3	*Bracket Assembly, Top	74-48672-01			
4	*Bracket, Paddle Board	74-38830-01			
☞ 5	*Module, SCSI Interface	54-23320-01			
☞ 6	*Cable Assembly, Flat 06 Cond.	17-04006-01			
7	*Isolator, Shock Ferrule	12-32626-03			
8	*Isolator, Shock Grommet	12-32626-04			
9	*Screw, Mach M3 Flat Hd	90-40122-04			
10	*Screw, Phi Pan Hd No. 4-40 x 1/4	90-09315-01			

FIG. & ITEM NO.	DESCRIPTION	DIGITAL ^C PART NO.	ECO CUT-IN TLZ04 00000	USED ON CODE	REF FIG NO.
46-	STORAGE ELEMENT, TLZ04				
	Code A – Used on TLZ04–JA	TLZ04–JA		A	30
	Code B – Used on TLZ04–JF	TLZ04–JF		B	30
1	*MOUNTING ASSEMBLY, TLZ04 ISE	70–28090–01			47
2	*BEZEL ASSEMBLY, WIDE WINDOW	70–28081–03			30,58
3	*Label, “Bar Code, Integrated Storage” (deleted) (Not Shown)	36–33151–07	00001		
4	*Label, “Bus ID Language Variant”	36–33181–02			
5	*Documentation, “Storage Device Add On Procedure” (Not Shown)	EK–BA44A–IN		B	
6	*Package Assembly (Not Shown)	37–01215–01		B	

  INDICATES FRU LEVEL PARTS.

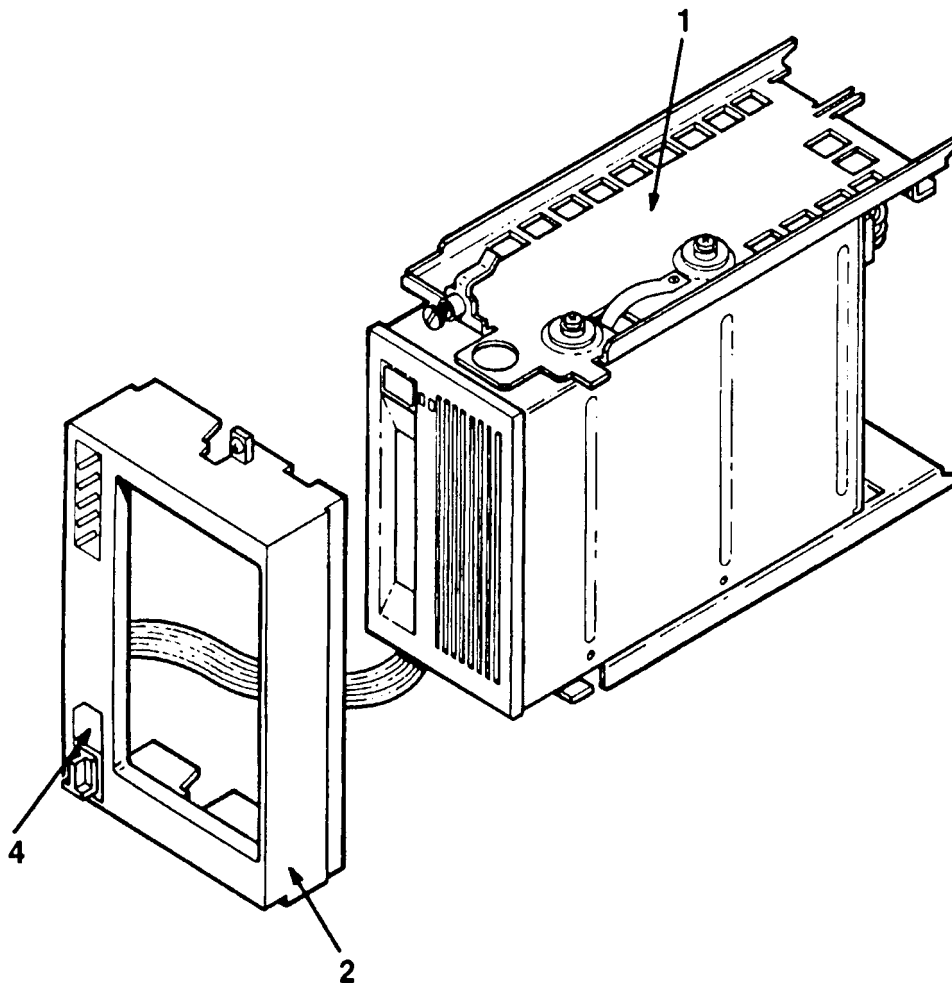

400ST-46-SC

Figure 46. Storage Element, TLZ04

THIS PAGE INTENTIONALLY LEFT BLANK

  INDICATES FRU LEVEL PARTS.

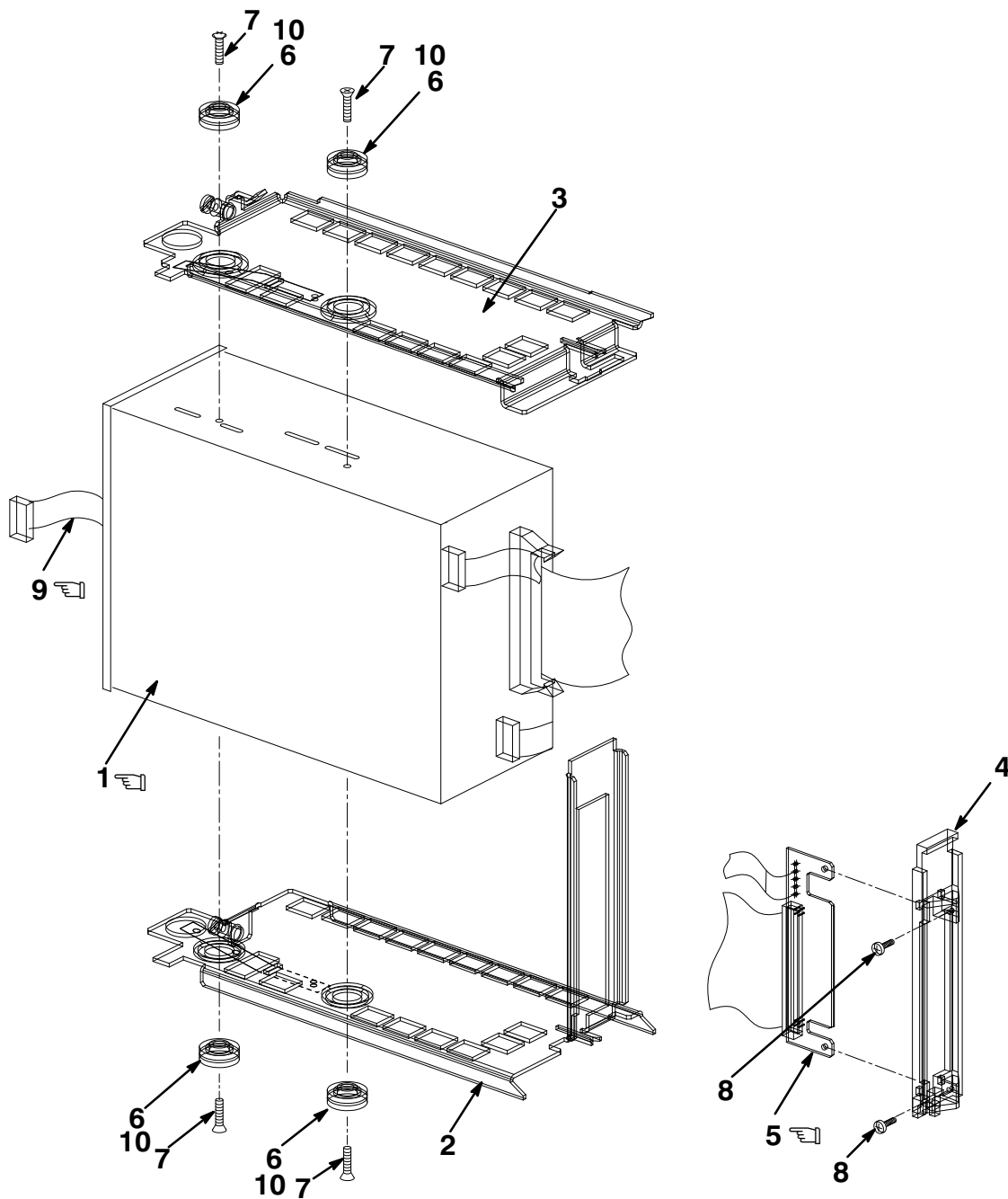

400ST-47-IL

Figure 47. Mounting Assembly, TLZ04 ISE

FIG. & ITEM NO.	DESCRIPTION	DIGITAL PART NO. ^B	ECO CUT-IN 70-28090 00000	USED ON CODE	REF FIG NO.
47-	MOUNTING ASSEMBLY, TLZ04 ISE	70-28090-01			46
☞1	*Tape Drive Assembly	TLZ04-AA			
2	*Bracket Assembly, Bottom	70-28078-01			
3	*Bracket, Top	70-28077-01			
4	*Bracket, Paddle Board	74-38830-01			
☞5	*Module, SCSI Interface Card	54-20136-03			
6	*Isolator, Shock (deleted)	12-32626-01	00001		
	*Isolator, Shock Grommet (added)	12-32626-04	00001		
7	*Screw, Machine No. M-3 14 mm	90-11163-01			
8	*Screw, Phi Pan Hd No. 4-40 x 1/4	90-09315-01			
☞9	*Cable Assembly, 10 Cond.	17-01936-02			
10	*Ferrule (added)	12-32626-03	00001		

INDICATES FRU LEVEL PARTS.

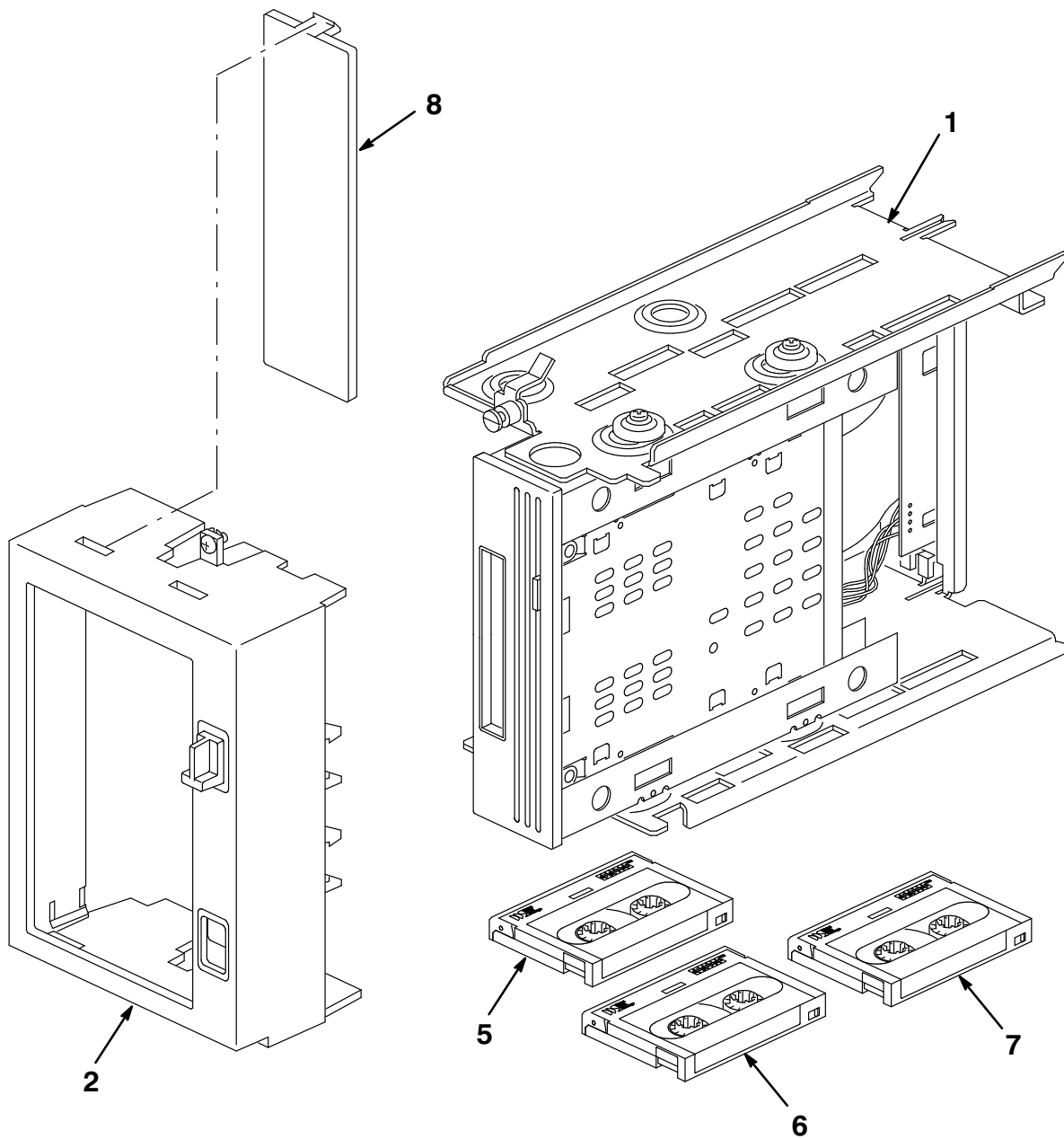

400ST-48-IL

Figure 48. Storage Element, TLZ07

FIG. & ITEM NO.	DESCRIPTION	DIGITAL PART NO. ^B	ECO CUT-IN TLZ07 00001	USED ON CODE	REF FIG NO.
48-	STORAGE ELEMENT, TLZ07 (See Note)				
	Code A – Used on TLZ07–JA	TLZ07–JA		A	30
	Code B – Used on TLZ07–JF	TLZ07–JF		B	30
1	*MOUNTING ASSEMBLY, BA400, DUAL SCSI	70–22866–01			50
2	*BEZEL/PCB ASSEMBLY, REMOVABLE MEDIA	70–29547–01			59
3	*Documentation, “Storage Device(s) Add On Procedures” (Not Shown)	EK–BA44A–IN		B	
4	*Package Assembly (Not Shown)	37–01215–05			
5	*Kit, OVMA VAX/AXP	QA–MT1AA–UP			
6	*Cartridge, Cleaning	TLZ04–HA			
7	*Cartridge, Single 4 MM, 4 GB	TLZ07–CA			
8	*Panel, Blank Filler	74–44062–01			
	Note: Supported Only If HSD05–JA/JF Is Installed In The Enclosure.				

INDICATES FRU LEVEL PARTS.

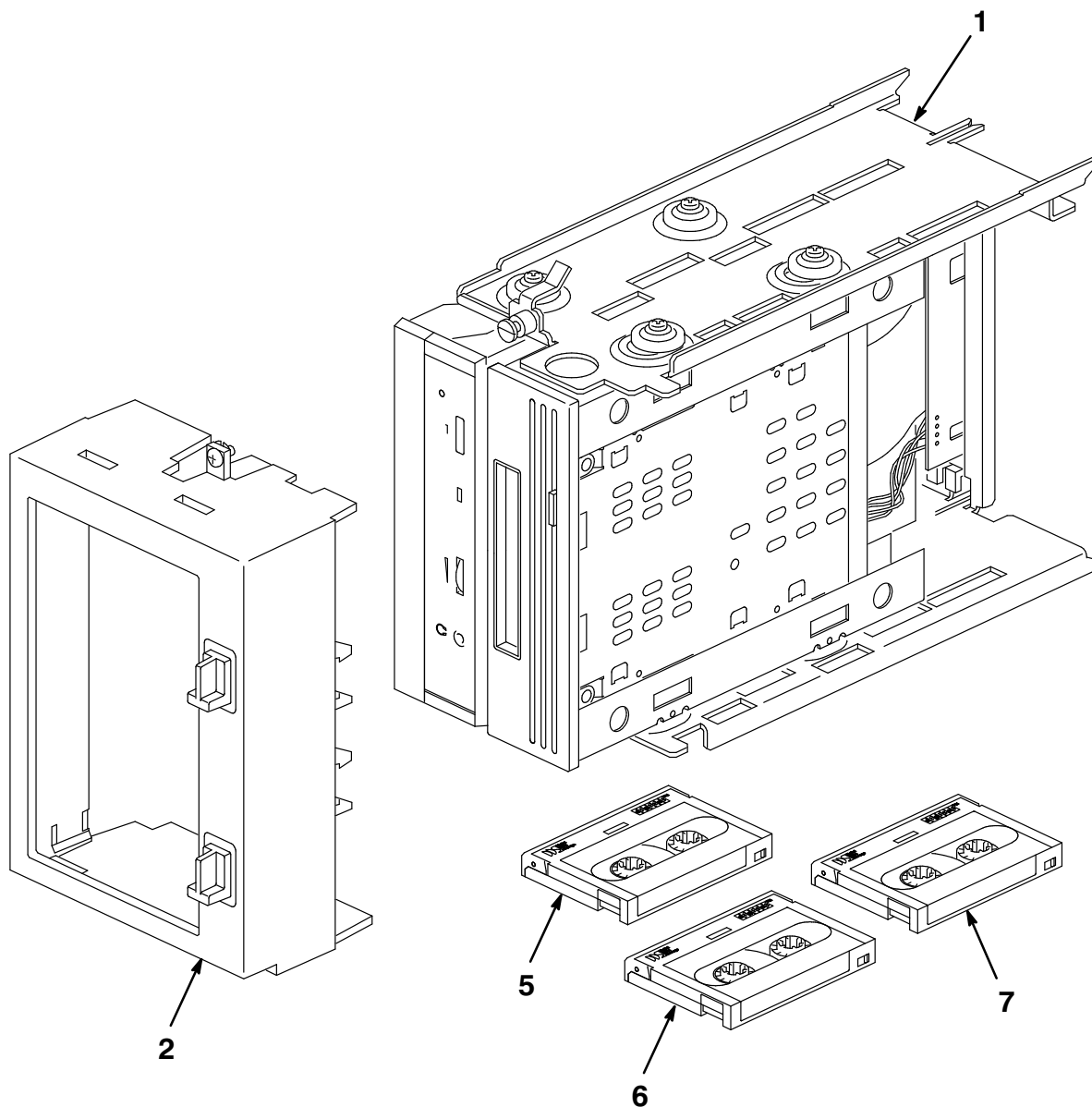

400ST-49-IL

Figure 49. Storage Element, DTLZ07

FIG. & ITEM NO.	DESCRIPTION	DIGITAL PART NO. ^B	ECO CUT-IN DLTZ07 00001	USED ON CODE	REF FIG NO.
49-	STORAGE ELEMENT, DLTZ07 (See Note)				
	Code A - Used on DLTZ07-JA Code B - Used on DLTZ07-JF	DLTZ07-JA DLTZ07-JF		A B	
1	*MOUNTING ASSEMBLY, BA400, DUAL SCSI	70-22866-02			50
2	*BEZEL/PCB ASSEMBLY, REMOVABLE MEDIA	70-29547-01			59
3	*Documentation, "Storage Device(s) Add On Procedures" (Not Shown)	EK-BA44A-IN		B	
4	*Package Assembly (Not Shown)	37-01215-05			
5	*Kit, OVMA VAX/AXP	QA-MT1AA-UP			
6	*Cartridge, Cleaning	TLZ04-HA			
7	*Cartridge, Single 4 MM, 4 GB	TLZ07-CA			
	Note: Supported Only If HSD05-JA/JF Is Installed In The Enclosure.				

 INDICATES FRU LEVEL PARTS.

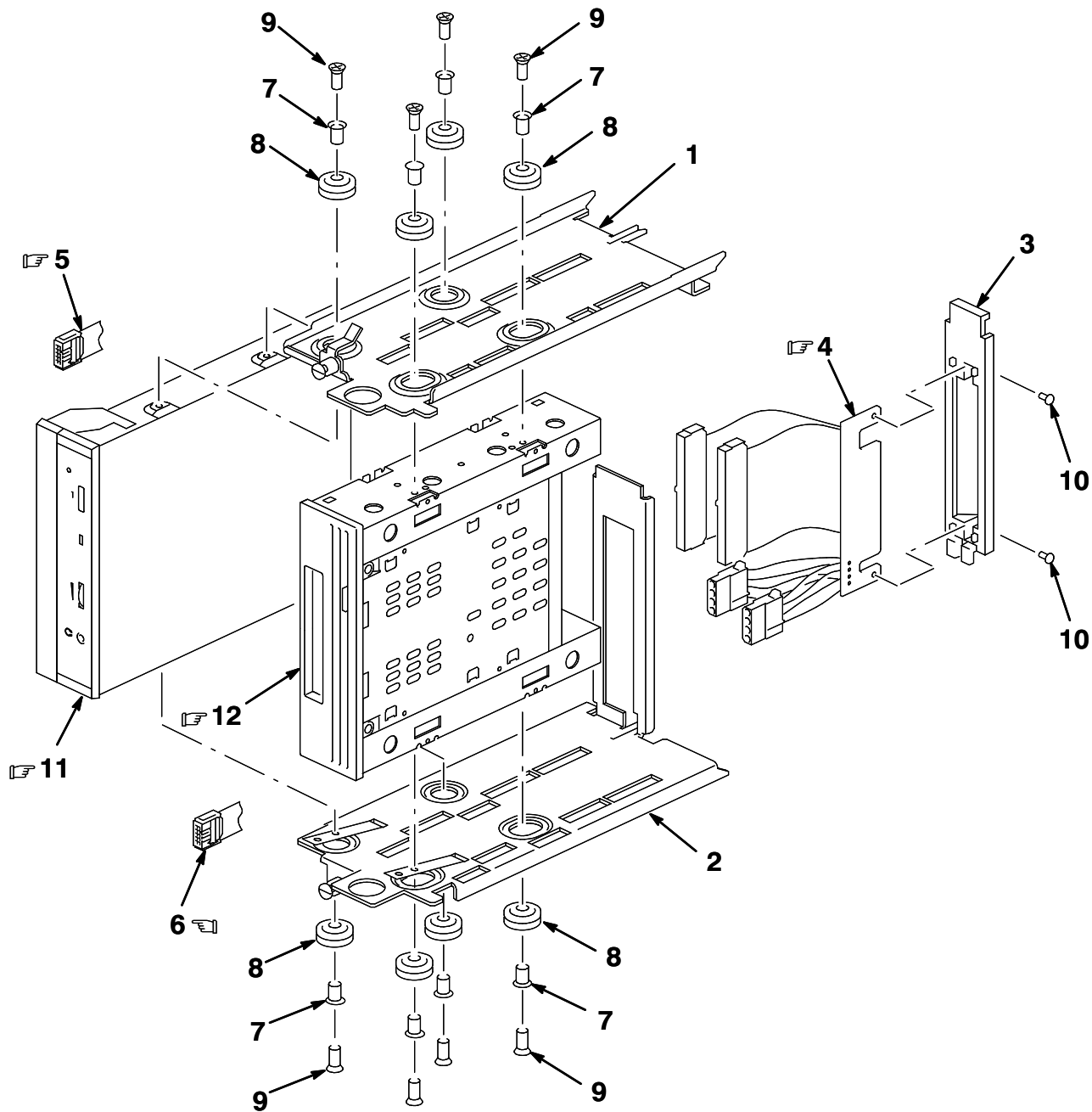

400ST-50-IL

Figure 50. Mounting Assembly, BA400 Dual SCSI

FIG. & ITEM NO.	DESCRIPTION	DIGITAL PART NO. ^A	ECO CUT-IN 7022866 00000	USED ON CODE	REF FIG NO.
50-	MOUNTING ASSEMBLY, BA400 DUAL SCSI	70-22866-01		A	48
	MOUNTING ASSEMBLY, BA400 DUAL SCSI	70-22866-02		B	49
1	*Bracket Assembly, Top	74-48670-01			
2	*Bracket Assembly, Bottom	74-48669-01			
3	*Bracket, Paddle Board	74-38830-01			
☞ 4	*Module, SCSI Interface	54-23320-03			
☞ 5	*Cable Assembly, Flat 06 Cond.	17-04006-01		B	
☞ 6	*Cable Assembly, Flat 06 Cond., 28AWG, 6 Pos.	17-03431-01			
7	*Isolator, Shock Ferrule	12-32626-03			
8	*Isolator, Shock Grommet	12-32626-04			
9	*Screw, Mach M3 Flat Hd	90-40122-04			
10	*Screw, Phi Pan Hd No. 4-40 x 1/4	90-09315-01			
☞ 11	*CD-ROM Drive Assembly, Half Height, Dual Speed, 5 1/4 Inch SCSI, 600 MB (Used On -02 Variation Only).	RRD43-AA		B	
☞ 12	*Tape Drive Assembly, Half Height, 5 1/4 Inch 8 GB, 4MM	TLZ07-BA			

FIG. & ITEM NO.	DESCRIPTION	DIGITAL ^A PART NO.	ECO CUT-IN TZ86 00000	USED ON CODE	REF FIG NO.
51-	STORAGE ELEMENT, TZ86 (See Note)				
	Code A – Used on TZ86-JA	TZ86-JA		A	30
	Code B – Used on TZ86-JF	TZ86-JF		B	30
1	*MOUNTING ASSEMBLY, TK85 ISE	70-28092-04			52
2	*BEZEL ASSEMBLY, TAPE DRIVE	70-27050-04			60
3	*Label, "Bus ID, LV"	36-33181-02			
4	*Documentation, "Storage Device(s) Add On Procedures" (Not Shown)	EK-BA44A-IN		B	
5	*Package Assembly (Not Shown)	37-01215-06		B	
	Note: Supported Only If HSD05-JA/JF Is Installed In The Enclosure.				

  INDICATES FRU LEVEL PARTS.

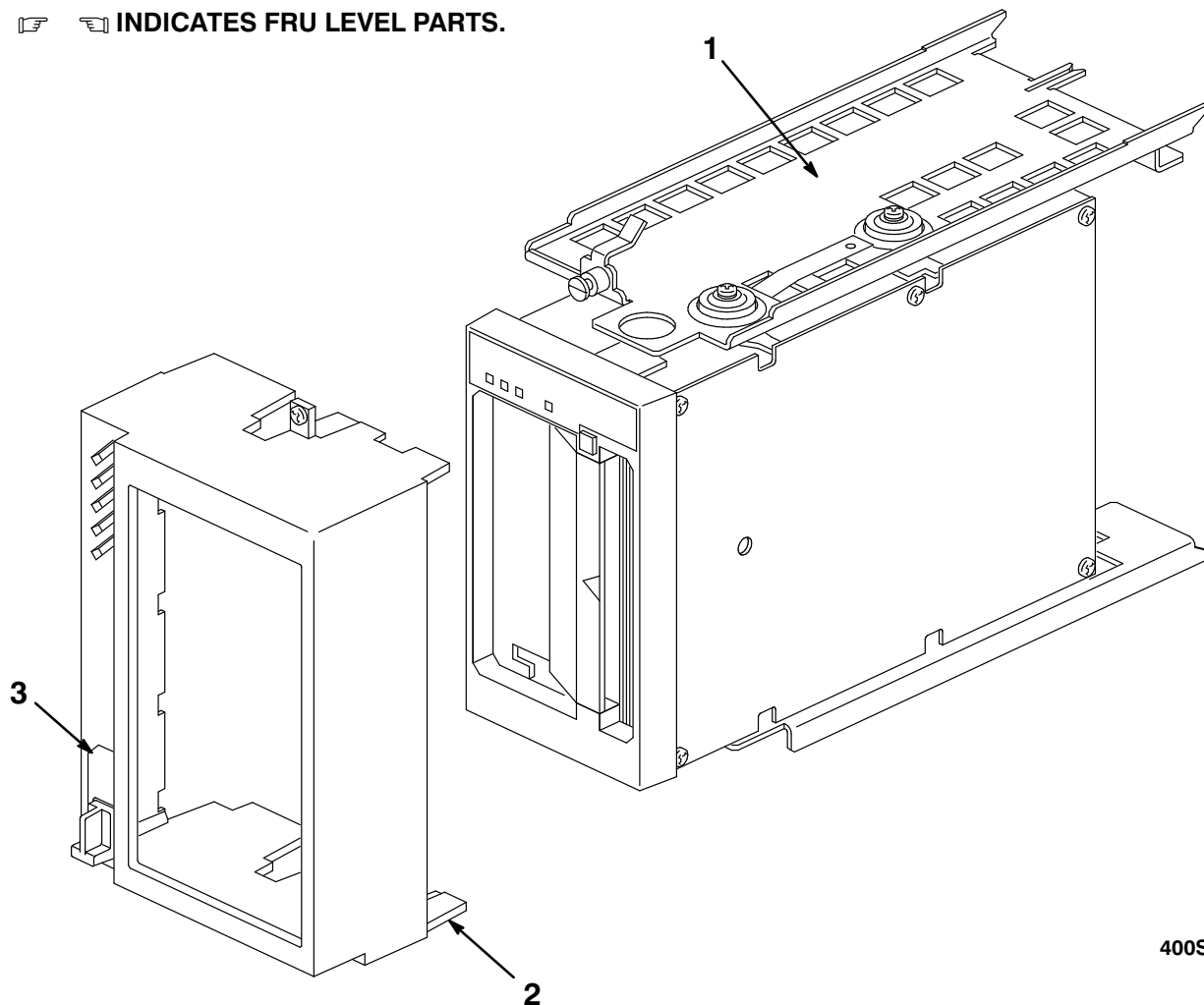

400ST-51-IL

Figure 51. Storage Element, TZ86

THIS PAGE INTENTIONALLY LEFT BLANK

INDICATES FRU LEVEL PARTS.

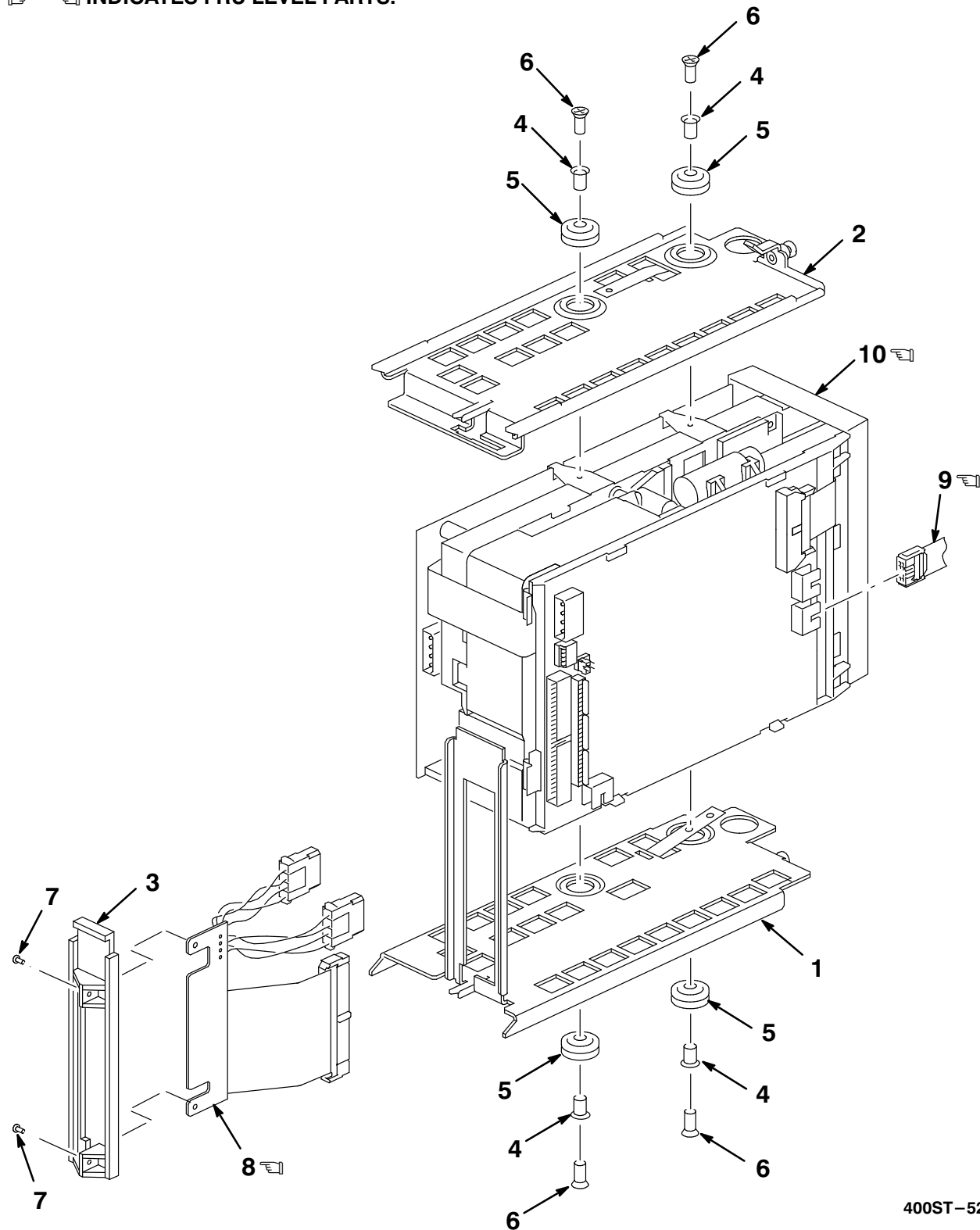

400ST-52-IL

Figure 52. Mounting Assembly, TZ86

FIG. & ITEM NO.	DESCRIPTION	DIGITAL PART NO.	ECO CUT-IN 7028092 00004	USED ON CODE	REF FIG NO.
52-	MOUNTING ASSEMBLY, TZ86	70-28092-04			51
1	*Bracket Assembly, Bottom Tape Drive	70-27413-01			
2	*Bracket Assembly, Top Tape Drive	70-27457-01			
3	*Bracket, Paddle Module	74-38830-01			
4	*Isolator, Shock Ferrule	12-32626-03			
5	*Isolator, Shock Grommet	12-32626-04			
6	*Screw, Mach Flat Hd No. 6-32 x 5/8	90-06025-02			
7	*Screw, Phi Pan Hd No. 4-40 x 1/4	90-09315-01			
F 8	*Module, SCSI Interface	54-20136-04			
F 9	*Cable Assembly, Flat, 10 Cond	17-01936-06			
F 10	*Tape Drive Assembly, TK86-BX	TZ86-BA			

FIG. & ITEM NO.	DESCRIPTION	DIGITAL PART NO. ^A	ECO CUT-IN TZ87 00000	USED ON CODE	REF FIG NO.
53-	STORAGE ELEMENT, TZ87 (See Note)				
	Code A – Used on TZ87–JA	TZ87–JA		A	30
	Code B – Used on TZ87–JF	TZ87–JF		B	30
1	*MOUNTING ASSEMBLY, TK85 ISE	70–28092–05			54
2	*BEZEL ASSEMBLY, TAPE DRIVE	70–27050–04			60
3	*Label, “Bus ID, LV”	36–33181–02			
4	*Documentation, “Storage Device(s) Add On Procedures” (Not Shown)	EK–BA44A–IN		B	
5	*Package Assembly (Not Shown)	37–01215–06		B	
	Note: Supported Only If HSD05–JA/JF Is Installed In The Enclosure.				

☞ ☞ INDICATES FRU LEVEL PARTS.

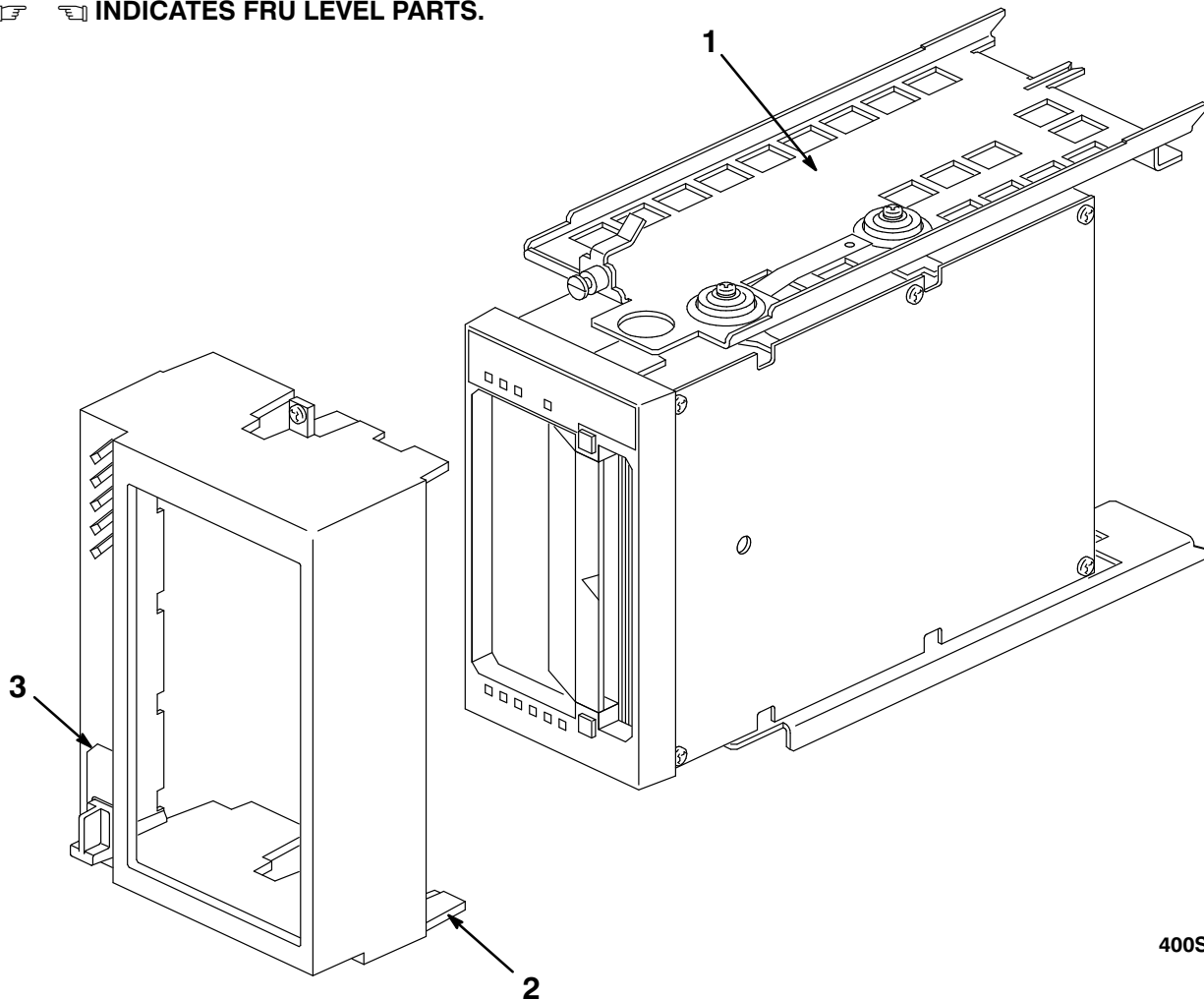

400ST-53-IL

Figure 53. Storage Element, TZ87

THIS PAGE INTENTIONALLY LEFT BLANK

  INDICATES FRU LEVEL PARTS.

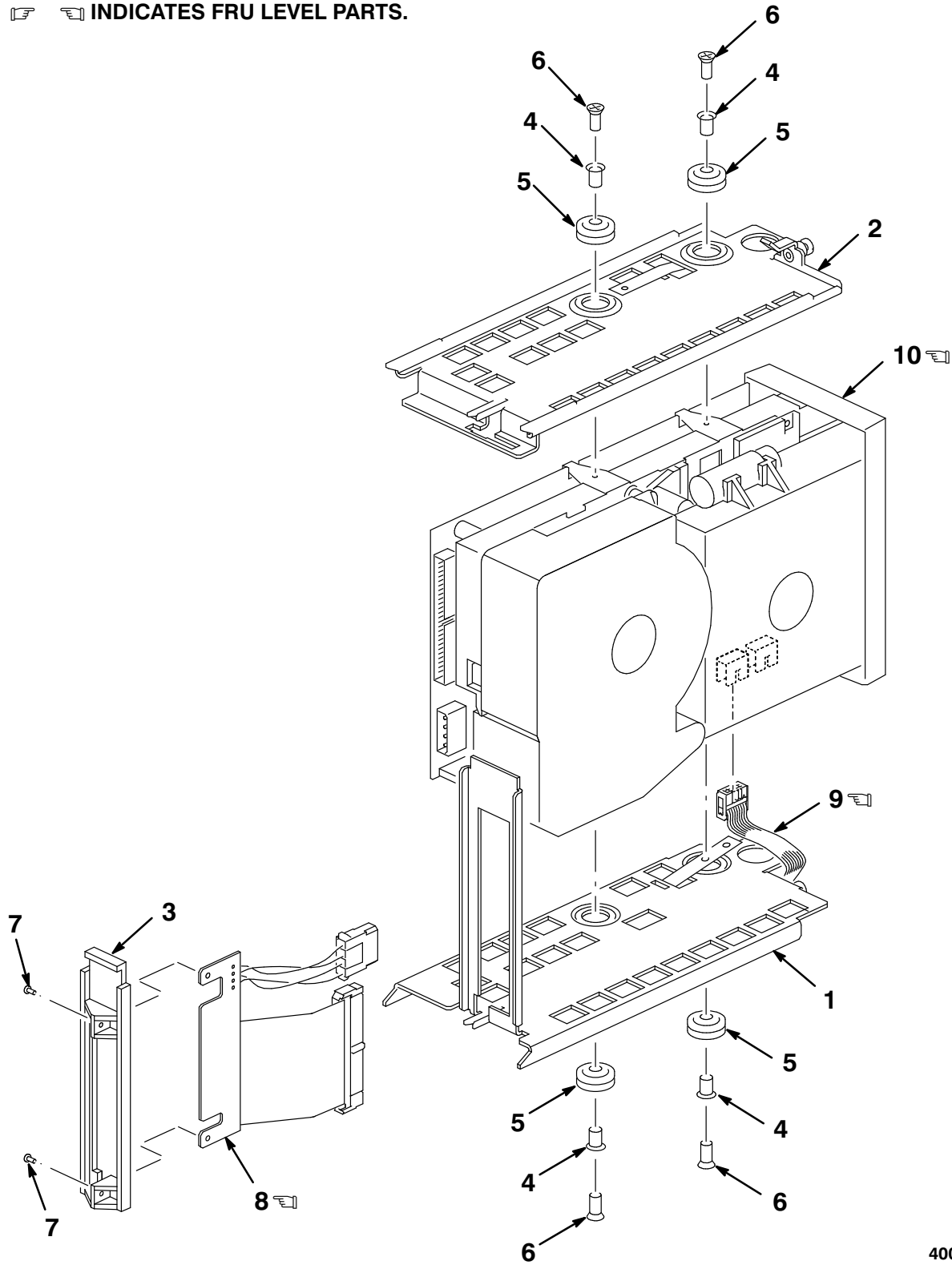

400ST-54-IL

Figure 54. Mounting Assembly, TZ87

FIG. & ITEM NO.	DESCRIPTION	DIGITAL PART NO. ^E	ECO CUT-IN 7028092 00004	USED ON CODE	REF FIG NO.
54-	MOUNTING ASSEMBLY, TZ87	70-28092-05			53
1	*Bracket Assembly, Bottom Tape Drive	70-27413-01			
2	*Bracket Assembly, Top Tape Drive	70-27457-01			
3	*Bracket, Paddle Module	74-38830-01			
4	*Isolator, Shock Ferrule	12-32626-03			
5	*Isolator, Shock Grommet	12-32626-04			
6	*Screw, Mach Flat Hd No. 6-32 x 5/8	90-06025-02			
7	*Screw, Phi Pan Hd No. 4-40 x 1/4	90-09315-01			
F 8	*Module, SCSI Interface	54-20136-05			
F 9	*Cable Assembly, Flat, 10 Cond	17-01936-01			
F 10	*Tape Drive Assembly, SCSI, 20 GB	TZ87-BA			

 INDICATES FRU LEVEL PARTS.

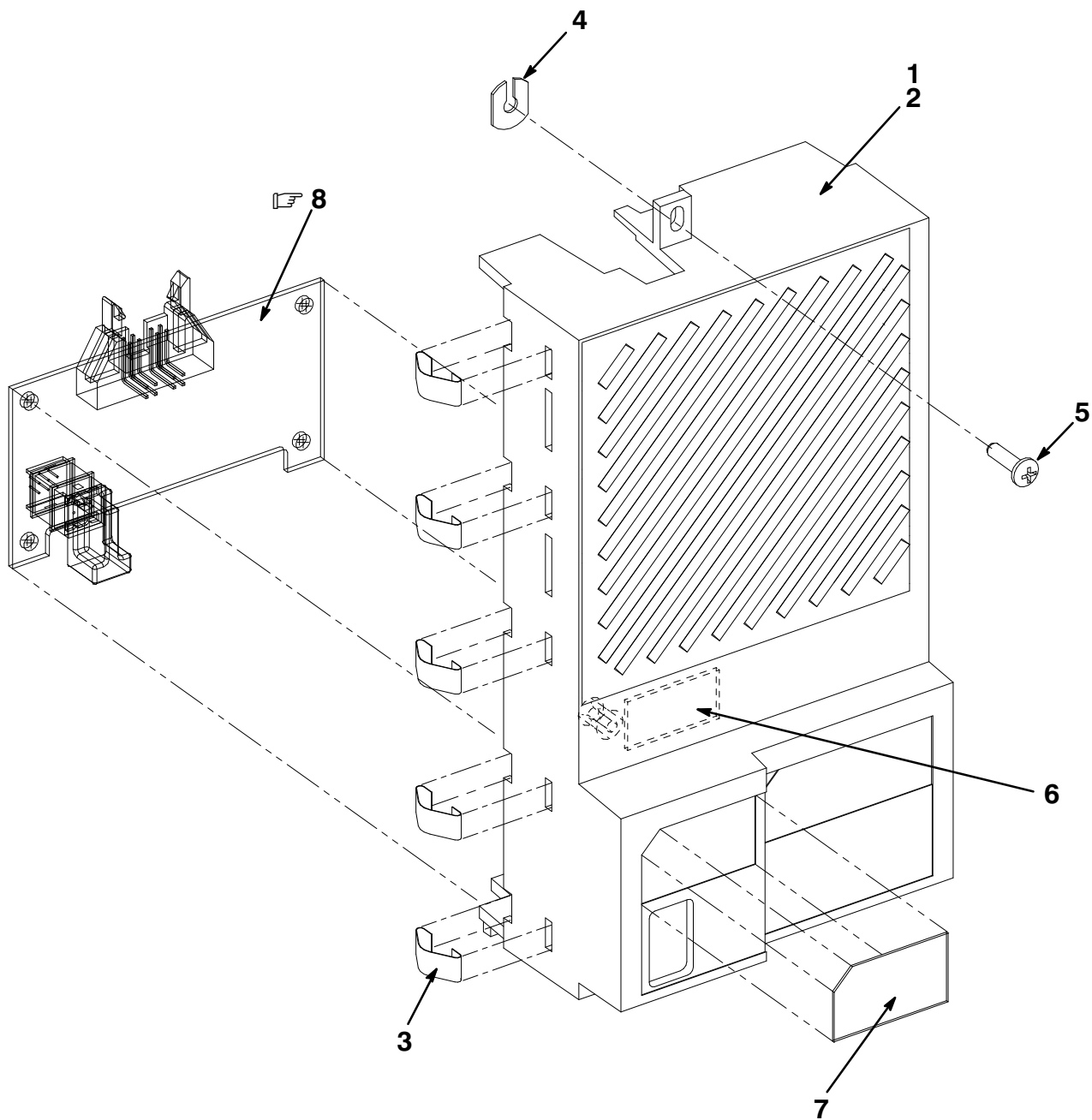

400ST-55-IL

Figure 55. Bezel Assembly, Disk Drive

FIG. & ITEM NO.	DESCRIPTION	DIGITAL PART NO.	ECO CUT-IN 70-27049 00001	USED ON CODE	REF FIG NO.
55-	BEZEL ASSEMBLY, DISK DRIVE	70-27049-05			30,31, 32,33 35,36
1	*BEZEL ASSEMBLY, DISK DRIVE	70-27049-03			
2	**Bezel, Drive	74-39272-03			
3	**Finger, Grounding	12-26922-01			
4	**Washer, Retainer	12-30421-01			
5	**Screw, Phi Pan Hd No. 6-32 x 5/16	90-06021-01			
6	**Tape, Velcro	12-32980-01			
7	*Label, "Bus ID"	36-33183-03			
☐8	*Module, SCSI Device ID Panel	54-20400-01			

FIG. & ITEM NO.	DESCRIPTION	DIGITAL PART NO. ^B	ECO CUT-IN 70-29478 00000	USED ON CODE	REF FIG NO.
56-	BEZEL ASSEMBLY, 3 1/2 INCH DSSI DISK DRIVE	70-29478-02			38,39 41,42
1	*Bezel, Blank	74-44325-01	00001		
2	*Module, DSSI Remote Front Panel	54-21530-01			
3	Finger, Non-Snag Grounding (Not Part of This Assembly, Shown for Reference Only.)	12-26922-01			

  INDICATES FRU LEVEL PARTS.

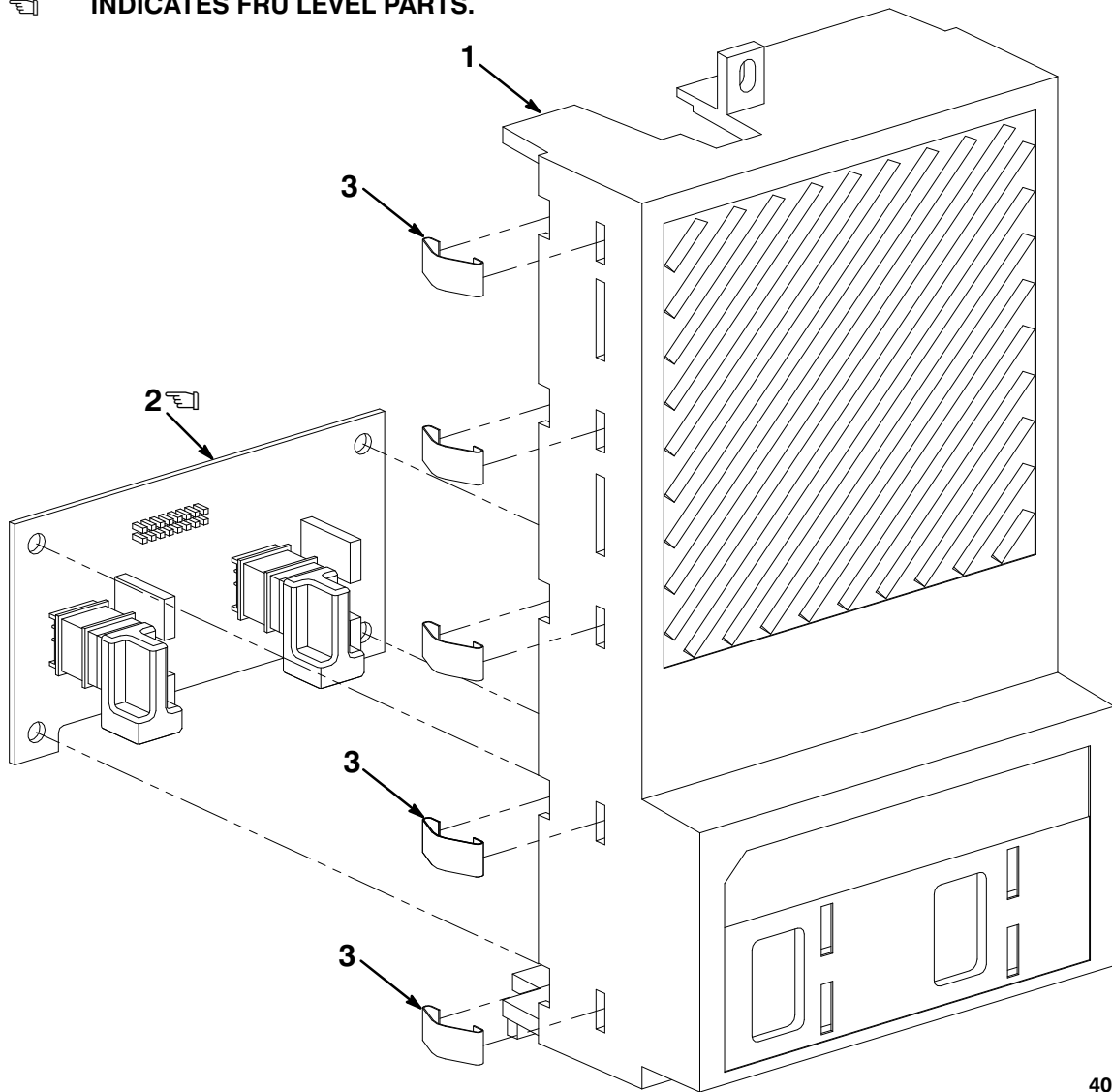

400ST-56-IL

Figure 56. Bezel Assembly, 3 1/2 Inch DSSI Disk Drive

THIS PAGE INTENTIONALLY LEFT BLANK

☞ ☞ INDICATES FRU LEVEL PARTS.

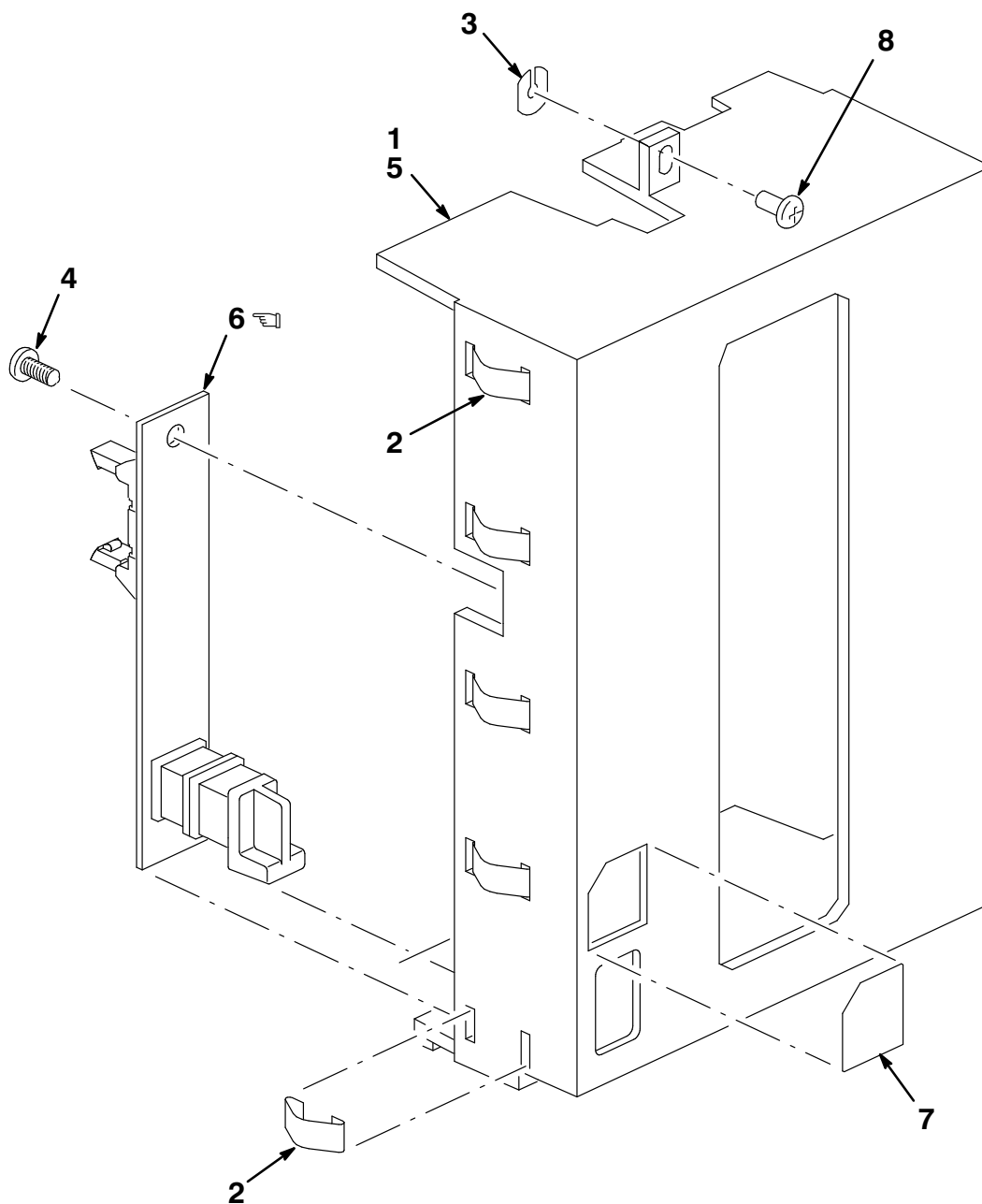

400ST-57-IL

Figure 57. Bezel Assembly, CD-ROM (BA400 Enclosure)

FIG. & ITEM NO.	DESCRIPTION	DIGITAL PART NO. ^B	ECO CUT-IN 7022865 00001	USED ON CODE	REF FIG NO.
57-	BEZEL ASSEMBLY, CD-ROM, (BA400) BEZEL ASSEMBLY, CD-ROM, (BA400)	70-22865-01 70-22865-02		A B	44
1	*Bezel, RRD43	74-48673-01		A	
2	*Finger, Grounding	12-26922-01		A	
3	*Washer, Retaining	12-30421-01		A	
4	*Screw, Mach Truss Hd No. 6-32 x 1/4	90-10971-01		A	
5	*Bezel Assembly, BA400, RRD43	70-22865-01		B	
6	*Module, RDAT ID	54-20438-01		B	
7	*Label, "Bus ID"	36-33181-01		B	
8	*Screw, Mach Pan Hd No. 6-32 x 1/4	90-06020-01		B	

☞ ☞ INDICATES FRU LEVEL PARTS.

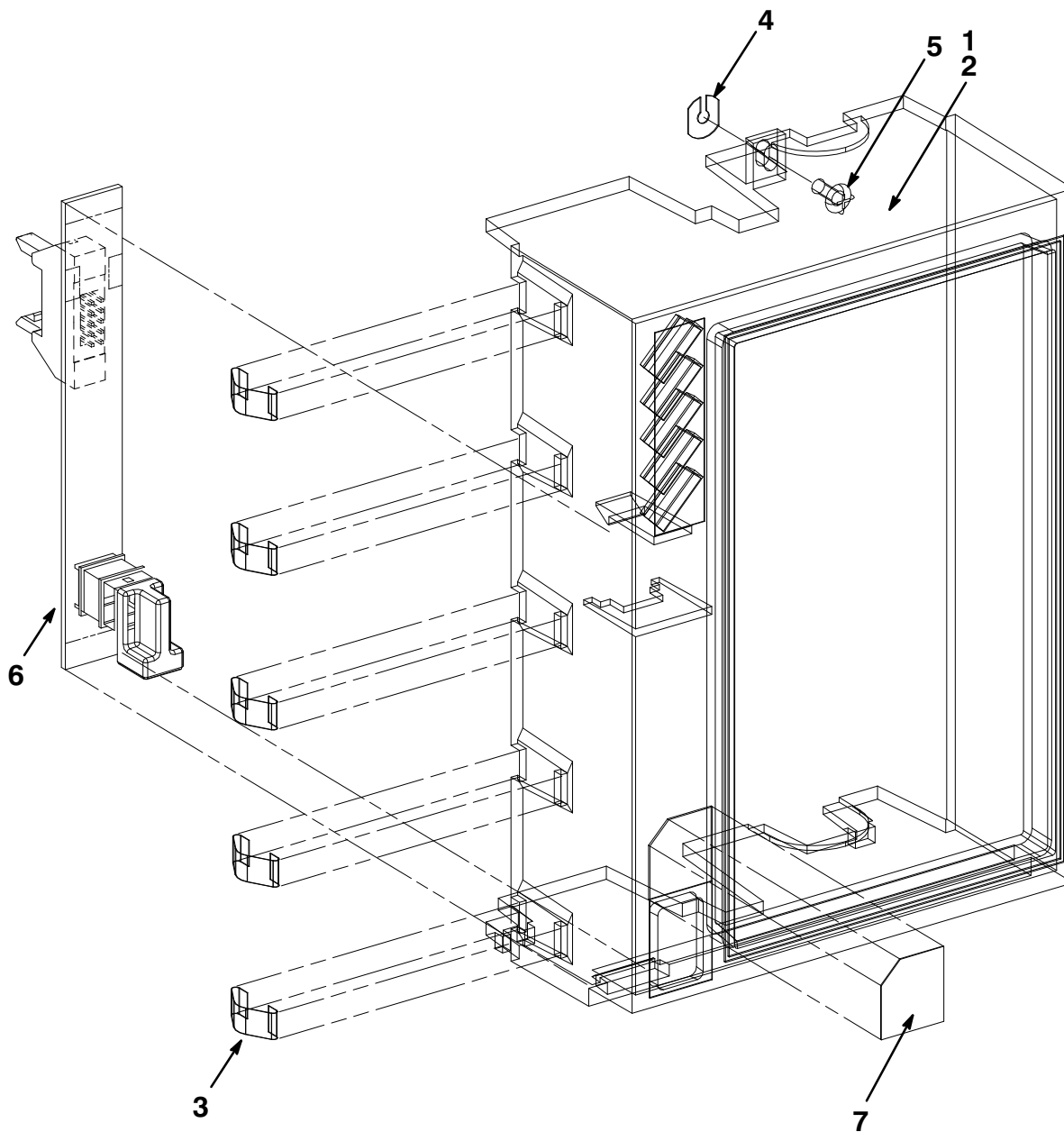

400ST-58-IL

Figure 58. Bezel Assembly, Wide Window

FIG. & ITEM NO.	DESCRIPTION	DIGITAL PART NO. ^B	ECO CUT-IN 70-28081 00000	USED ON CODE	REF FIG NO.
58-	BEZEL ASSEMBLY, WIDE WINDOW	70-28081-03			30,46
1	*Bezel Assembly, Wide Window	70-28081-01			
2	**Bezel, Wide Window	74-41159-01			
3	**Finger, Grounding	12-26922-01			
4	**Washer, Retaining	12-30421-01			
5	**Screw, Machine Phi Pan Hd No. 6-32 x 5/16	90-06021-01			
6	*Module, RDAT ID	54-20438-01			
7	*Label, "Bus ID"	36-33181-01			

FIG. & ITEM NO.	DESCRIPTION	DIGITAL ^A PART NO.	ECO CUT-IN 7029547 00000	USED ON CODE	REF FIG NO.
59-	BEZEL/PCB ASSEMBLY, REMOVABLE MEDIA BEZEL/PCB ASSEMBLY, REMOVABLE MEDIA	70-29547-01 70-29547-02		A B	48,49
1	*Bezel Assembly	70-29547-02		A	
2	*Finger, Grounding	12-26922-01		B	
3	*Washer, Retaining	12-30421-01		B	
 4	*Module. CD-ROM ID	54-21547-01		A	
5	*Bezel, Removable Media, Dual	74-44060-01		B	
6	*Screw, Mach Pan Hd No. 6-32 x 5/16	90-06021-01		B	

  INDICATES FRU LEVEL PARTS.

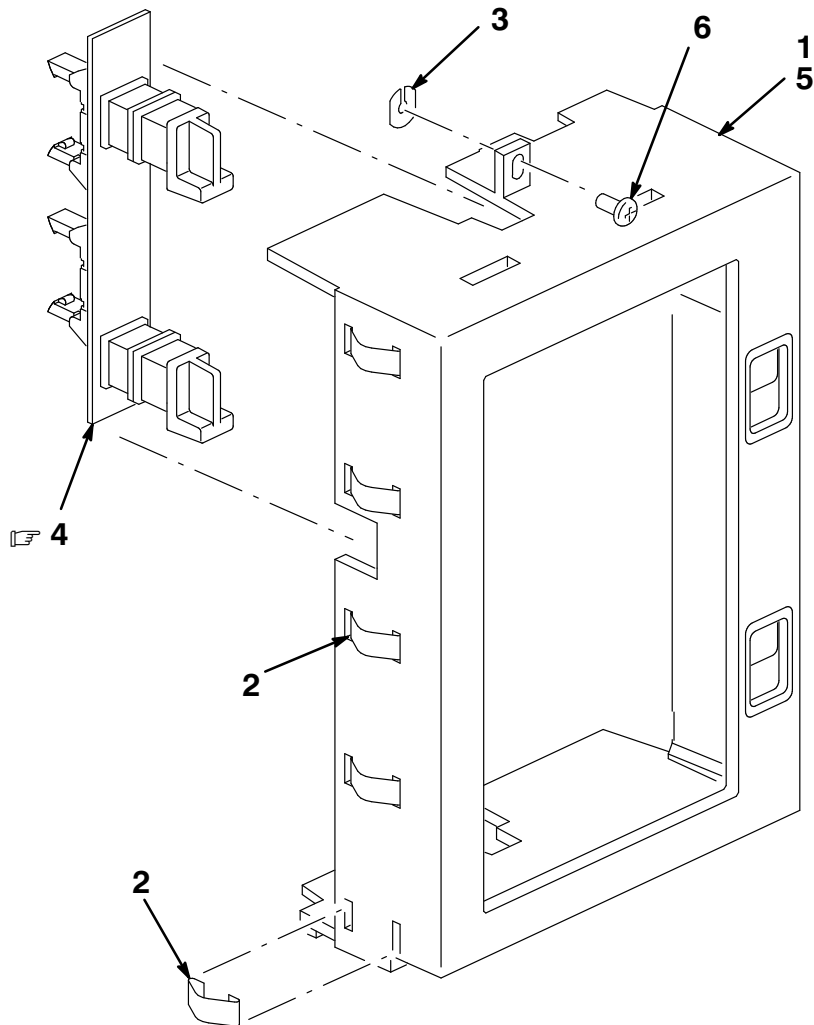

400ST-59-IL

Figure 59. Bezel/PCB Assembly, Removable Media

THIS PAGE INTENTIONALLY LEFT BLANK

FIG. & ITEM NO.	DESCRIPTION	DIGITAL ^B PART NO.	ECO CUT-IN 7027050 00001	USED ON CODE	REF FIG NO.
60-	BEZEL ASSEMBLY, TAPE DRIVE	70-27050-04			51,53
1	**BEZEL ASSEMBLY, TAPE DRIVE	70-27050-01			
2	**Bezel, Tape Drive	74-39273-01			
3	**Finger, Grounding	12-26922-01			
4	**Washer, Retaining	12-30421-01			
5	**Screw, Phi Pan Hd No. 6-32 x 5/16	90-06021-01			
6	*Label, "Bus ID"	36-33181-01			
 7	*Module, RDAT ID	54-20438-01			

  INDICATES FRU LEVEL PARTS.

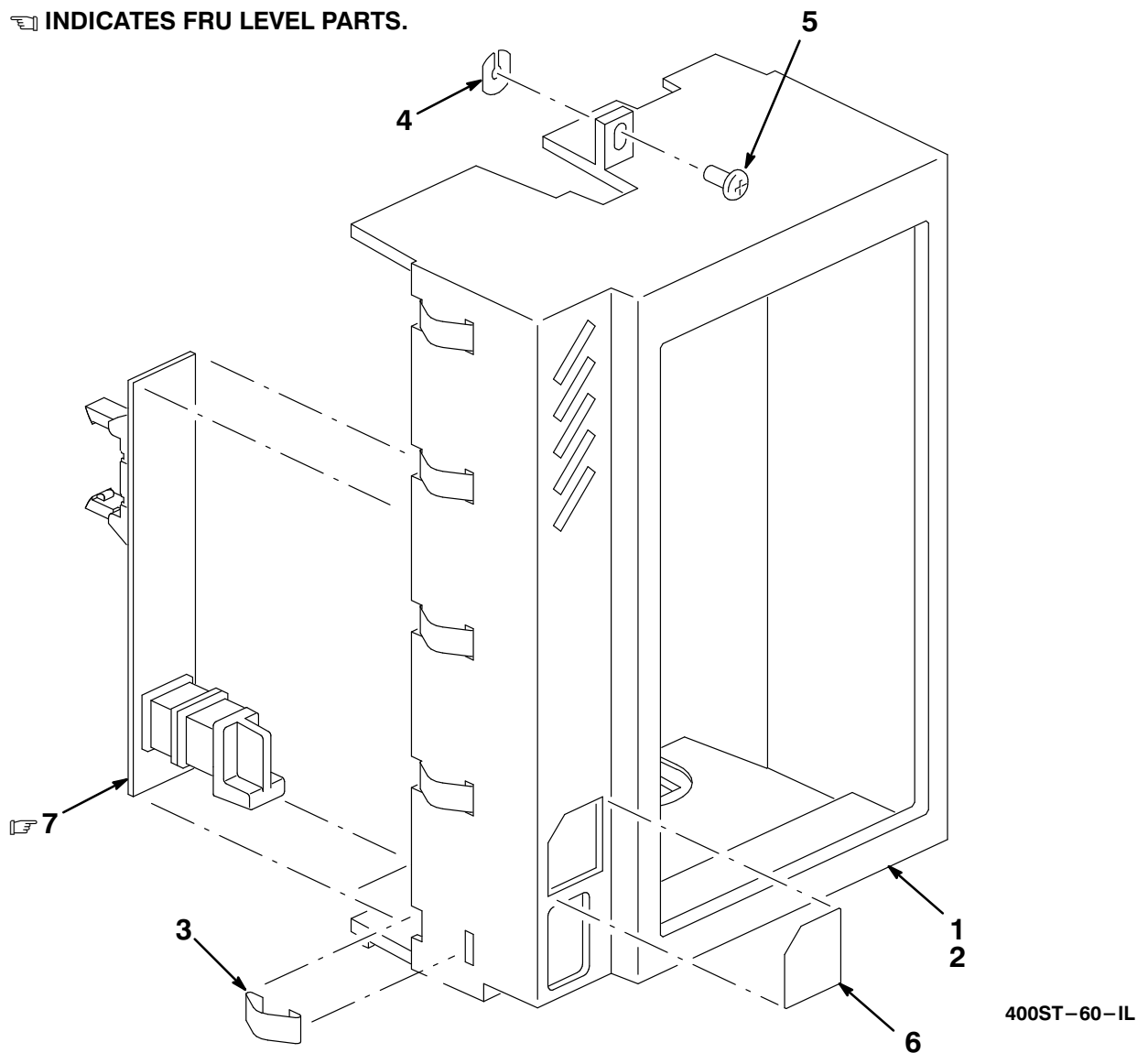
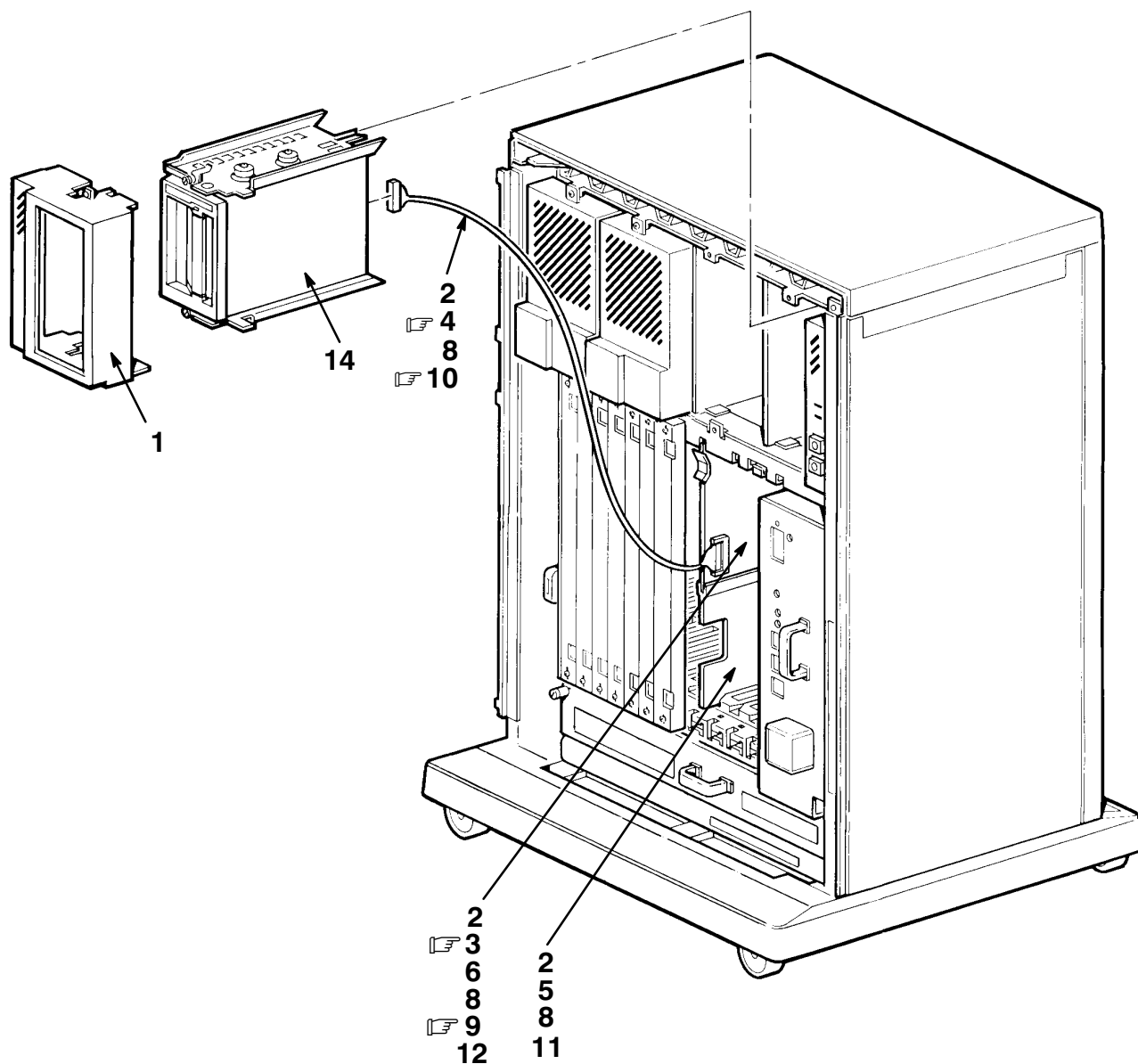

Figure 60. Bezel Assembly, Tape Drive

THIS PAGE INTENTIONALLY LEFT BLANK

TK DRIVES

INDICATES FRU LEVEL PARTS.



400ST-61-SC

Figure 61. Typical TK System Mounting and Cabling

FIG. & ITEM NO.	DESCRIPTION	DIGITAL PART NO.	ECO CUT-IN	USED ON CODE	REF FIG NO.
61 -	TYPICAL TK SYSTEM MOUNTING and CABLING				
1	*BEZEL ASSEMBLY, TAPE DRIVE	70-27050-02			66
2	*KIT, Q-bus CONTROLLER	TQK70-SA			
☞3	**Module, Tape Controller	M7559-00			
☞4	**Cable Assembly	17-01363-01			
5	**Panel, Blank Dual	74-33507-01			
6	**Label, "Module Number" (See Note)	36-26883-45			
7	**Label, "BAXXX Rev" (Rolled) (Not Shown)	36-29163-07			
8	*KIT, Q-bus CONTROLLER	TQK50-SA			
☞9	**Module, Tape Controller	M7546-00			
☞10	**Cable Assembly	17-01363-01			
11	**Panel, Blank Dual	74-33507-01			
12	**Label, "Module Number" (See Note)	36-26883-11			
13	**Label, "BAXXX Rev" (Rolled) (Not Shown)	36-29163-07			
14	*TK70E Tape Drive Assembly	TK70E-AA			64
	*TK70E Tape Drive Assembly	TK70E-AF			64
	*TK50E Tape Drive Assembly	TK50E-AA			62
	*TK50E Tape Drive Assembly	TK50E-AF			62
	Note: Label placement is on Module Bulkhead.				

FIG. & ITEM NO.	DESCRIPTION	DIGITAL PART NO. ^A	ECO CUT-IN TK50E 00000	USED ON CODE	REF FIG NO.
62-	STORAGE ELEMENT, TK50E				
	Code A – Used on TK50E-AA	TK50E-AA		A	61
	Code B – Used on TK50E-AF	TK50E-AF		B	61
1	*MOUNTING ASSEMBLY, TK50 ISE	70-22839-01			63
2	*BEZEL ASSEMBLY, TAPE DRIVE	70-27050-02			64
3	*Documentation, "Storage Device Add On Procedure" (Not Shown)	EK-BA44A-IN		B	
4	*Package Assembly (Not Shown)	37-01215-02		B	

  INDICATES FRU LEVEL PARTS.

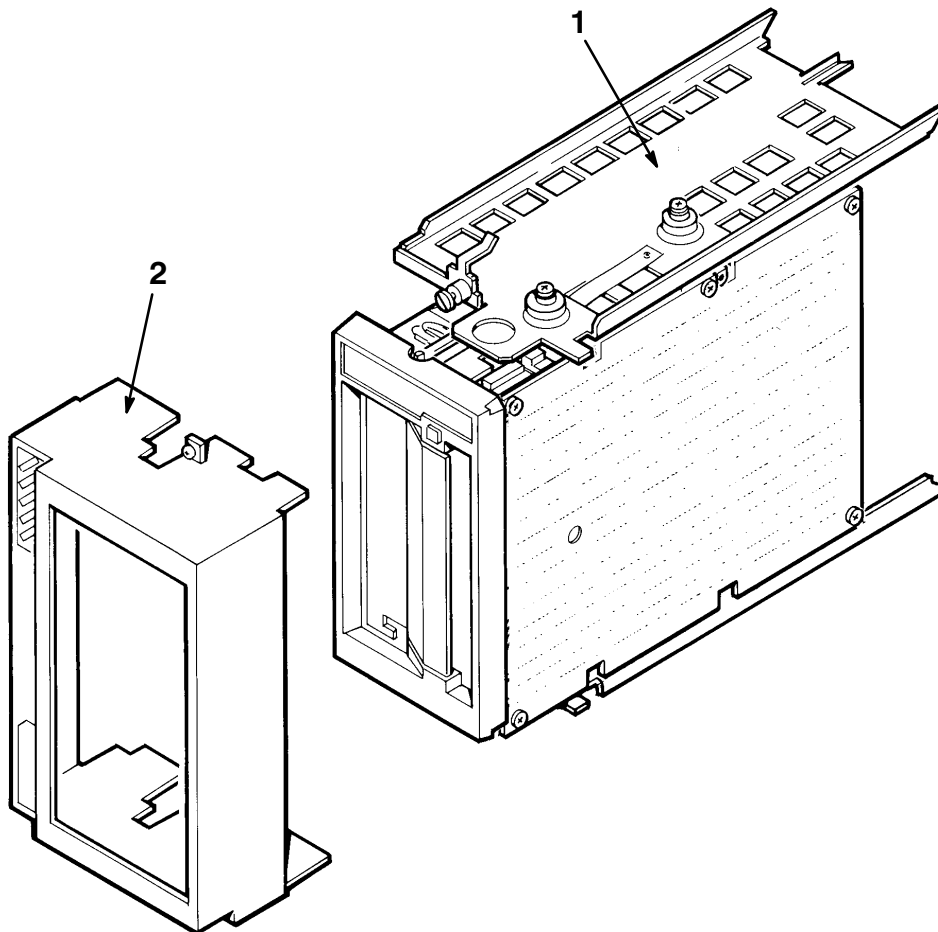

400ST-62-SC

Figure 62. Storage Element, TK50E

THIS PAGE INTENTIONALLY LEFT BLANK

☞ INDICATES FRU LEVEL PARTS.

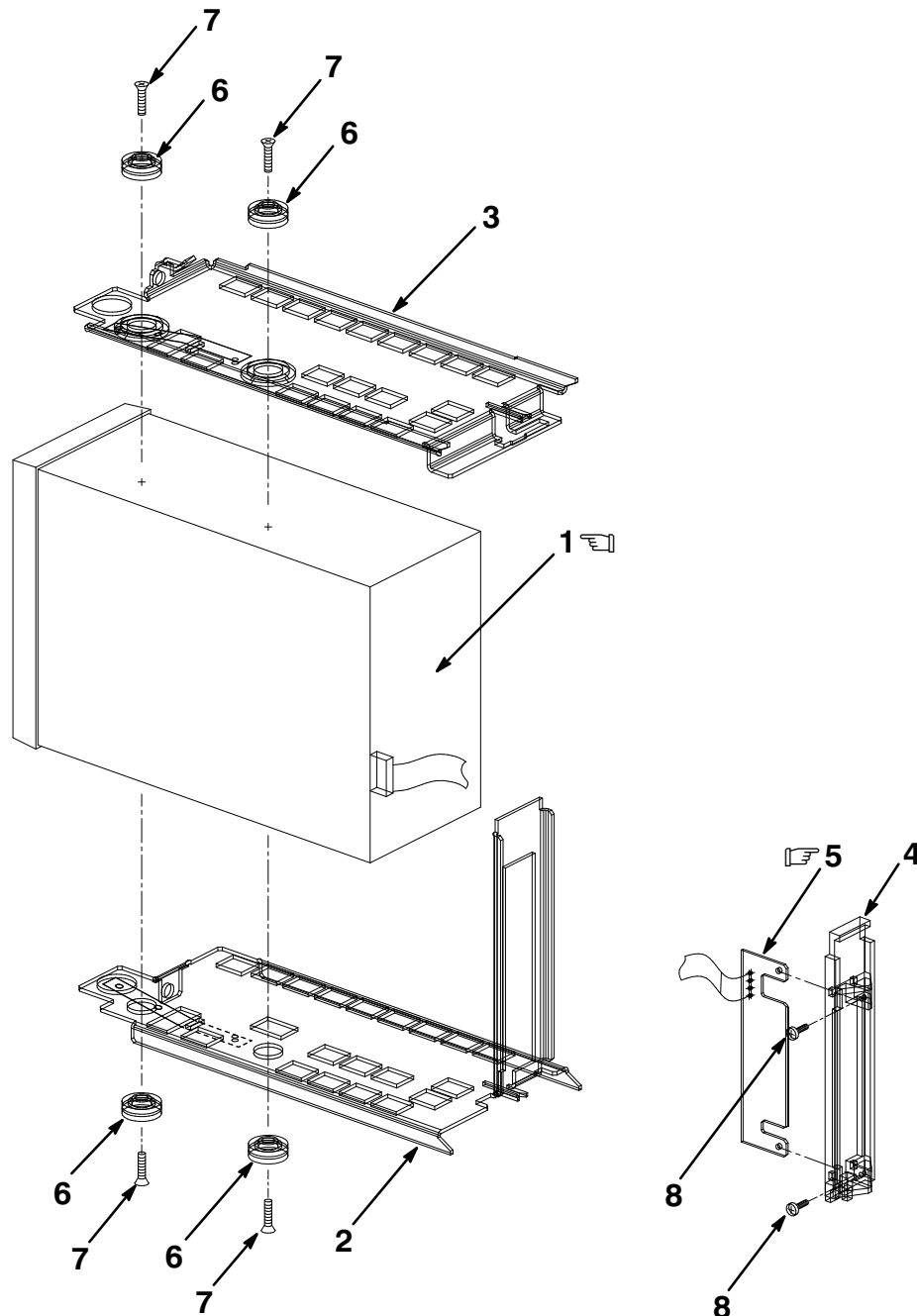

400ST-63-IL

Figure 63. Mounting Assembly, TK50 ISE

FIG. & ITEM NO.	DESCRIPTION	DIGITAL PART NO. ^B	ECO CUT-IN 70-22839 00000	USED ON CODE	REF FIG NO.
63-	MOUNTING ASSEMBLY, TK50 ISE	70-22839-01			61
☞1	*Tape Drive Assembly	TK50-EA			
2	*Bracket Assembly, Bottom Tape Drive	70-27413-01			
3	*Bracket Assembly, Top Tape Drive	70-27457-01			
4	*Bracket, Paddle Board	74-38830-01			
☞5	*Module, Interface Card	54-20136-02			
6	*Isolator, Shock (deleted)	12-32626-01	00001		
6	*Isolator, Shock Grommet Only (added)	12-32626-04	00001		
6	*Isolator, Shock Ferrule (added)	12-32626-03	00001		
7	*Screw, Machine Flat Hd No. 6-32 x 5/8	90-06025-02			
8	*Screw, Phi Pan Hd No. 4-40 x 1/4	90-09315-01			

FIG. & ITEM NO.	DESCRIPTION	DIGITAL PART NO. ^B	ECO CUT-IN TK70E 00000	USED ON CODE	REF FIG NO.
64-	STORAGE ELEMENT, TK70E				
	Code A – Used on TK70E-AA	TK70E-AA		A	61
	Code B – Used on TK70E-AF	TK70E-AF		B	61
1	*MOUNTING ASSEMBLY, TK70 ISE	70-28088-01			65
2	*BEZEL ASSEMBLY, TAPE DRIVE	70-27050-02			62
3	*Label, Bar Code, Integrated Storage (deleted) (Not Shown)	36-33151-01	00001		
4	*Documentation, "Storage Device Add On Procedure" (Not Shown)	EK-BA44A-IN		B	
5	*Package Assembly (Not Shown)	37-01215-02		B	

 INDICATES FRU LEVEL PARTS.

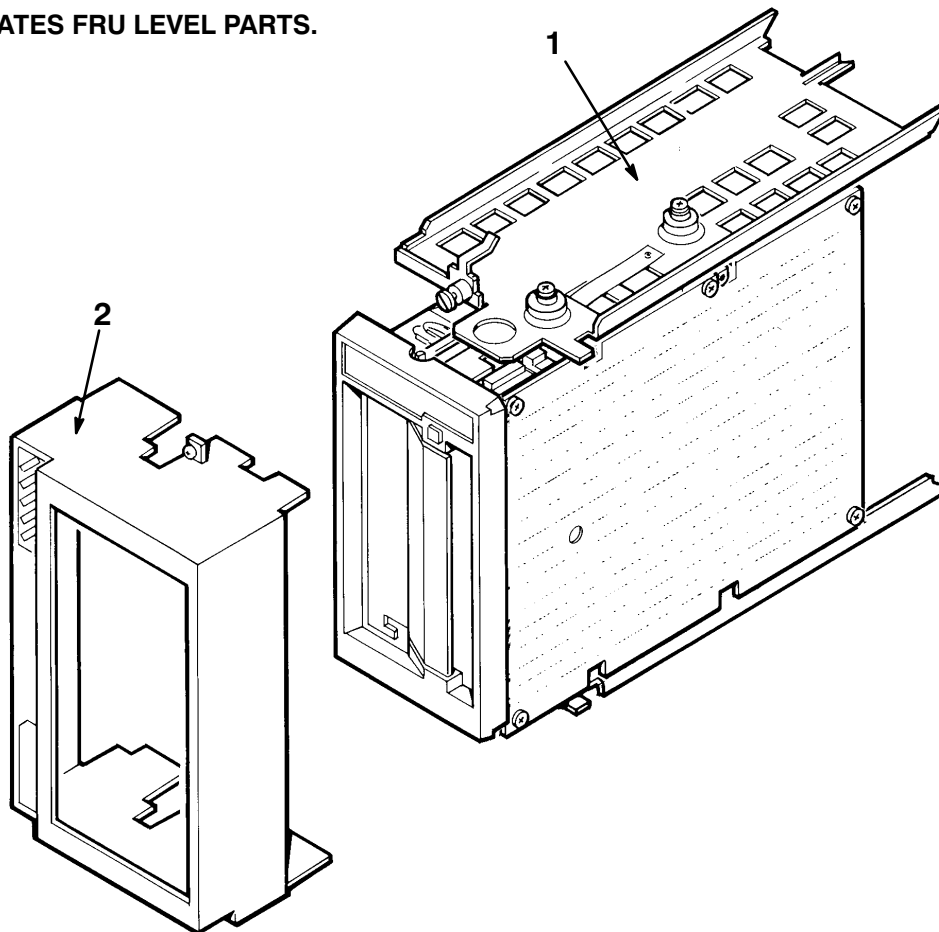

400ST-64-SC

Figure 64. Storage Element, TK70E

THIS PAGE INTENTIONALLY LEFT BLANK

INDICATES FRU LEVEL PARTS.

PARTS LIST

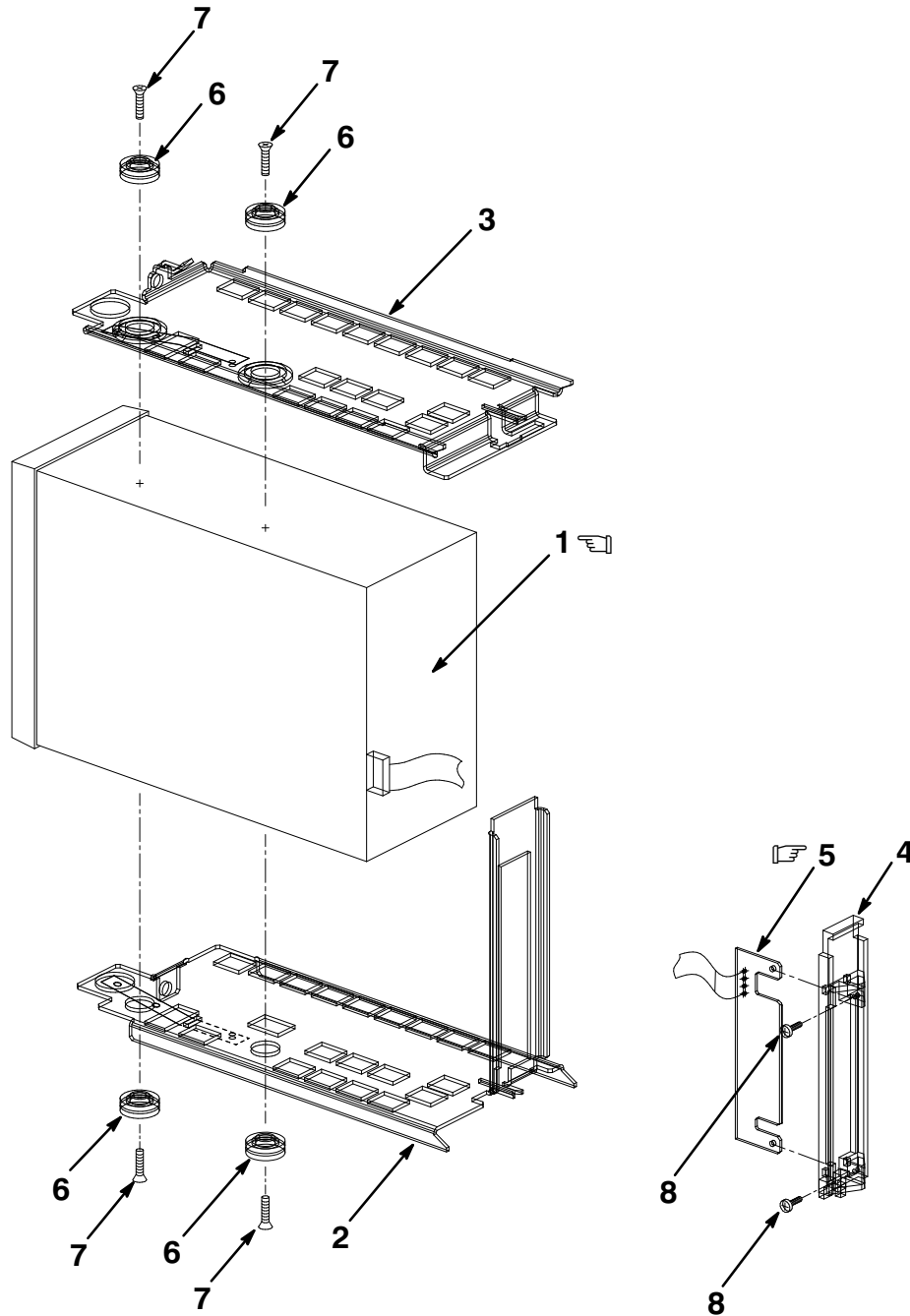

400ST-65-IL

Figure 65. Mounting Assembly, TK70 ISE

FIG. & ITEM NO.	DESCRIPTION	DIGITAL PART NO. ^B	ECO CUT-IN 70-28088 00000	USED ON CODE	REF FIG NO.
65-	MOUNTING ASSEMBLY, TK70 ISE	70-28088-01			64
1	*Tape Drive Assembly	TK70-EA			
2	*Bracket Assembly, Bottom Tape Drive	70-27413-01			
3	*Bracket Assembly, Top Tape Drive	70-27457-01			
4	*Bracket, Paddle Board	74-38830-01			
5	*Module, Interface Card	54-20136-02			
6	*Isolator, Shock (deleted)	12-32626-01	00001		
6	*Isolator, Shock Grommet Only (added)	12-32626-04	00001		
6	*Isolator, Shock Ferrule Only (added)	12-32626-03	00001		
7	*Screw, Machine Flat Hd No. 6-32 x 5/8	90-06025-02			
8	*Screw, Phi Pan Hd No. 4-40 x 1/4	90-09315-01			

FIG. & ITEM NO.	DESCRIPTION	DIGITAL PART NO. ^B	ECO CUT-IN 70-27050 00000	USED ON CODE	REF FIG NO.
66-	BEZEL ASSEMBLY, TAPE DRIVE	70-27050-02			61
1	*Bezel, Tape Drive	74-39273-01			
2	*Finger, Grounding	12-26922-01			
3	*Washer, Retaining	12-30421-01			
4	*Screw, Phi Pan Hd No. 6-32 x 5/16	90-06021-01			
					Ω

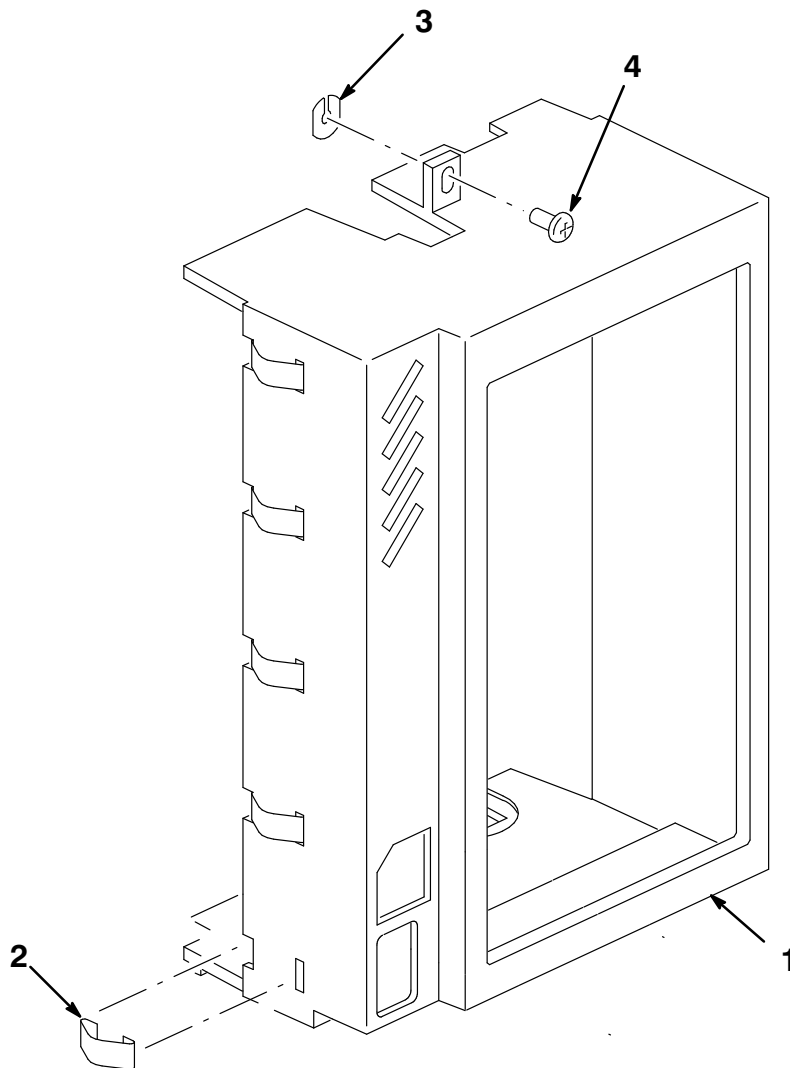

400ST-66-IL

Figure 66. Bezel Assembly, Tape Drive

THIS PAGE INTENTIONALLY LEFT BLANK

PART NUMBER/DESCRIPTION INDEX 

THIS PAGE INTENTIONALLY LEFT BLANK

INDEX BY DIGITAL PART NUMBER
400 SERIES MASS STORAGE DEVICES

PART NO.	DESCRIPTION	FIG NO.	ITEM NO.
12-19245-01	Battery Pack	22	6
12-26922-01	Finger, Grounding	27	3
12-26922-01	Finger, Grounding	29	3
12-26922-01	Finger, Grounding	55	3
12-26922-01	Finger, Grounding	57	2
12-26922-01	Finger, Grounding	58	3
12-26922-01	Finger, Grounding	59	2
12-26922-01	Finger, Grounding	60	3
12-26922-01	Finger, Grounding	66	2
12-26922-01	Finger, Non-Snag Grounding	28	3
12-26922-01	Finger, Non-Snag Grounding	56	3
12-28766-19	Encoder Set, Lens (DSSI Unit ID Plug)	22	11
12-29258-01	Connector, Terminator	1	4
12-30421-01	Washer, Retainer	27	4
12-30421-01	Washer, Retainer	55	4
12-30421-01	Washer, Retaining	29	4
12-30421-01	Washer, Retaining	57	3
12-30421-01	Washer, Retaining	58	4
12-30421-01	Washer, Retaining	59	3
12-30421-01	Washer, Retaining	60	4
12-30421-01	Washer, Retaining	66	3
12-30552-01	Connector, SCSI Term 50 Pos Champ Hsg	30	4
12-32626-01	Isolator, Shock (deleted)	18	7
12-32626-01	Isolator, Shock (deleted)	4	6
12-32626-01	Isolator, Shock (deleted)	47	6
12-32626-01	Isolator, Shock (deleted)	63	6
12-32626-01	Isolator, Shock (deleted)	65	6
12-32626-03	Ferrule (added)	47	10
12-32626-03	Isolator, Shock (Ferrule)	24	6
12-32626-03	Isolator, Shock (Ferrule)	26	6
12-32626-03	Isolator, Shock Ferrule	10	7
12-32626-03	Isolator, Shock Ferrule	13	7
12-32626-03	Isolator, Shock Ferrule	40	8
12-32626-03	Isolator, Shock Ferrule	43	8
12-32626-03	Isolator, Shock Ferrule	45	7
12-32626-03	Isolator, Shock Ferrule	50	7
12-32626-03	Isolator, Shock Ferrule	52	4
12-32626-03	Isolator, Shock Ferrule	54	4
12-32626-03	Isolator, Shock Ferrule	7	7
12-32626-03	Isolator, Shock Ferrule Only (added)	65	6
12-32626-03	Isolator, Shock, Ferrule	22	8
12-32626-04	Isolator, Shock Grommet (added)	18	7
12-32626-04	Isolator, Shock (Grommet)	24	6A
12-32626-04	Isolator, Shock (Grommet)	26	6A
12-32626-04	Isolator, Shock Grommet	10	5
12-32626-04	Isolator, Shock Grommet	13	5
12-32626-04	Isolator, Shock Grommet	34	6
12-32626-04	Isolator, Shock Grommet	37	6
12-32626-04	Isolator, Shock Grommet	40	9
12-32626-04	Isolator, Shock Grommet	43	9
12-32626-04	Isolator, Shock Grommet	45	8
12-32626-04	Isolator, Shock Grommet	50	8
12-32626-04	Isolator, Shock Grommet	52	5
12-32626-04	Isolator, Shock Grommet	54	5

INDEX BY DIGITAL PART NUMBER
400 SERIES MASS STORAGE DEVICES

PART NO.	DESCRIPTION	FIG NO.	ITEM NO.
12-32626-04	Isolator, Shock Grommet	7	5
12-32626-04	Isolator, Shock Grommet (added)	4	6
12-32626-04	Isolator, Shock Grommet (added)	47	6
12-32626-04	Isolator, Shock Grommet Only (added)	63	6
12-32626-04	Isolator, Shock Grommet Only (added)	65	6
12-32626-04	Isolator, Shock, Grommet	22	8
12-32980-01	Tape, Velcro	27	6
12-32980-01	Tape, Velcro	55	6
12-33377-01	Cover, 50 Pin IDC Connector	30	6
12-34462-01	Screw, Shoulder Hd No. 6-32 x 1/2 (added)	18	8
12-34462-01	Screw, Shoulder Hd No. 6-32 x 1/2 (added)	18	9
12-34462-01	Screw, Shoulder No. 6-32	37	7
12-34462-01	Screw, Shoulder No. 6-32 x 1/2 (added)	4	7
12-34462-01	Screw, Shoulder No. 6-32 x 1/2 (added)	4	8
12-34462-02	Screw, Shoulder No. 6-32	34	7
17-01363-01	Cable Assembly	61	10
17-01363-01	Cable Assembly	61	4
17-01936-01	Cable Assembly, Flat, 10 Cond	54	9
17-01936-02	Cable Assembly, 10 Cond.	47	9
17-01936-06	Cable Assembly, Flat, 10 Cond	52	9
17-02659-03	Cable Assembly, 50 Cond, Molded, Shielded	30	5
17-02659-03	Cable Assembly, 50 Cond, Molded, Shielded	44	7
17-02706-01	Cable Assembly, 10 Cond	18	11
17-02706-01	Cable Assembly, 10 Cond	22	7
17-02706-01	Cable Assembly, 10 Cond	4	10
17-02887-01	Cable Assembly, 10 Cond.	34	9
17-03428-01	Cable Assembly, RFP 7 in. Female Flat	10	15
17-03428-01	Cable Assembly, RFP 7 in. Female Flat	13	15
17-03428-01	Cable Assembly, RFP 7 in. Female Flat	40	7
17-03428-01	Cable Assembly, RFP 7 in. Female Flat	43	7
17-03428-01	Cable Assembly, RFP 7 in. Female Flat	7	15
17-03431-01	Cable Assembly, Flat 06 Cond., 28AWG, 6 Pos.	50	6
17-03498-01	Cable Assembly, 06 Cond.	37	9
17-04006-01	Cable Assembly, Flat 06 Cond.	45	6
17-04006-01	Cable Assembly, Flat 06 Cond.	50	5
29-27889-01	Module, RZ56 Drive	31	8
29-27890-01	Disk Assembly, RZ56	31	9
29-28158-01	Disk Assembly, RZ57	32	9
29-28159-01	Module, RZ57 Drive	32	8
36-18940-02	Label, "Switch Marker"	2	3
36-18940-02	Label, "Switch Marker"	3	3
36-18940-02	Label, "Switch Marker"	14	3
36-18940-02	Label, "Switch Marker"	15	3
36-18940-02	Label, "Switch Marker"	16	3
36-18940-02	Label, "Switch Marker"	17	3
36-18940-02	Label, "Switch Marker"	23	3
36-18940-02	Label, "Switch Marker"	25	3
36-18940-02	Label, "Switch Marker" (deleted)	31	3
36-18940-02	Label, "Switch Marker" (deleted)	32	3
36-18940-02	Label, "Switch Marker"	19	3
36-18940-02	Label, "Switch Marker"	20	3
36-18940-02	Label, "Switch Marker"	21	3
36-26883-11	Label, "Module Number"	61	12

INDEX BY DIGITAL PART NUMBER
400 SERIES MASS STORAGE DEVICES

PART NO.	DESCRIPTION	FIG NO.	ITEM NO.
36-26883-45	Label, "Module Number"	61	6
36-29163-07	Label, "BAXXX Rev" (Rolled) (Not Shown)	61	7
36-29163-07	Label, "BAXXX Rev" (Rolled) (Not Shown)	61	13
36-33151-01	Label, "Bar Code, Integrated Storage (deleted)(Not Shown)64		3
36-33151-02	Label, "Bar Code, Integrated Storage"(deleted)(Not Shown)14		4
36-33151-03	Label, "Bar Code" (Not Shown) (deleted)	2	4
36-33151-04	Label, "Bar Code, Integrated Storage" (Not Shown)(deleted)15		4
36-33151-05	Label, "Bar Code, Integrated Storage" (deleted)(Not Shown)31		4
36-33151-05	Label, "Bar Code, Integrated Storage" (deleted)(Not Shown)32		4
36-33151-07	Label, "Bar Code, Integrated Storage" (deleted)(Not Shown)46		3
36-33181-01	Label, "Bus ID"	29	6
36-33181-01	Label, "Bus ID"	58	7
36-33181-01	Label, "Bus ID"	57	7
36-33181-01	Label, "Bus ID"	60	6
36-33181-02	Label, "Bus ID Language Variant"	46	4
36-33181-02	Label, "Bus ID" (Language Variant)	23	4
36-33181-02	Label, "Bus ID" (Language Variant)	25	4
36-33181-02	Label, "Bus ID, LV"	44	3
36-33181-02	Label, "Bus ID, LV"	51	3
36-33181-02	Label, "Bus ID, LV"	53	3
36-33183-01	Label, "Drive Control"	27	7
36-33183-02	Label, "Drive No. 2 Language Variant"	14	5
36-33183-02	Label, "Drive No. 2 Language Variant"	15	5
36-33183-02	Label, "Drive No. 2 Language Variant"	16	4
36-33183-02	Label, "Drive No. 2 Language Variant"	17	4
36-33183-02	Label, "Drive No. 2 Language Variant"	19	4
36-33183-02	Label, "Drive No. 2 Language Variant"	20	4
36-33183-02	Label, "Drive No. 2 Language Variant"	21	4
36-33183-02	Label, "Drive No. 2 Language Variant"	2	5
36-33183-02	Label, "Drive No. 2 Language Variant"	3	4
36-33183-03	Label, "Bus ID"	27	8
36-33183-03	Label, "Bus ID"	55	7
36-33183-04	Label, "No. 2 Language Variant"	14	6
36-33183-04	Label, "No. 2 Language Variant"	15	6
36-33183-04	Label, "No. 2 Language Variant"	16	5
36-33183-04	Label, "No. 2 Language Variant"	17	5
36-33183-04	Label, "No. 2 Language Variant"	2	6
36-33183-04	Label, "No. 2 Language Variant"	3	5
36-33183-04	Label, "No. 2 Language Variant"	31	5
36-33183-04	Label, "No. 2 Language Variant"	32	5
36-33183-04	Label, "No. 2 Language Variant"	33	3
36-33183-04	Label, "No. 2 Language Variant"	35	3
36-33183-04	Label, "No. 2 Language Variant"	36	3
36-33183-04	Label, "No. 2 Language Variant"	19	5
36-33183-04	Label, "No. 2 Language Variant"	20	5
36-33183-04	Label, "No. 2 Language Variant"	21	5
37-01186-07	Package Assembly (Bulk Shipment) (Not Shown)	16	8
37-01186-07	Package Assembly (Bulk Shipment) (Not Shown)	17	7
37-01215-01	Package Assembly (Not Shown)	11	4
37-01215-01	Package Assembly (Not Shown)	12	4
37-01215-01	Package Assembly (Not Shown)	14	8
37-01215-01	Package Assembly (Not Shown)	15	8
37-01215-01	Package Assembly (Not Shown)	16	7
37-01215-01	Package Assembly (Not Shown)	17	7

INDEX BY DIGITAL PART NUMBER
400 SERIES MASS STORAGE DEVICES

PART NO.	DESCRIPTION	FIG NO.	ITEM NO.
37-01215-01	Package Assembly (Not Shown)	19	7
37-01215-01	Package Assembly (Not Shown)	20	7
37-01215-01	Package Assembly (Not Shown)	21	7
37-01215-01	Package Assembly (Not Shown)	31	7
37-01215-01	Package Assembly (Not Shown)	32	7
37-01215-01	Package Assembly (Not Shown)	33	5
37-01215-01	Package Assembly (Not Shown)	35	5
37-01215-01	Package Assembly (Not Shown)	36	5
37-01215-01	Package Assembly (Not Shown)	38	4
37-01215-01	Package Assembly (Not Shown)	39	4
37-01215-01	Package Assembly (Not Shown)	41	4
37-01215-01	Package Assembly (Not Shown)	42	4
37-01215-01	Package Assembly (Not Shown)	46	6
37-01215-01	Package Assembly (Not Shown)	5	4
37-01215-01	Package Assembly (Not Shown)	6	4
37-01215-01	Package Assembly (Not Shown)	8	4
37-01215-01	Package Assembly (Not Shown)	9	4
37-01215-02	Package Assembly (Not Shown)	62	4
37-01215-02	Package Assembly (Not Shown)	64	5
37-01215-04	Package Assembly (Not Shown)	2	8
37-01215-04	Package Assembly (Not Shown)	3	7
37-01215-04	Package Assembly (Not Shown)	44	6
37-01215-05	Package Assembly (Not Shown)	48	4
37-01215-05	Package Assembly (Not Shown)	49	4
37-01215-06	Package Assembly (Not Shown)	23	6
37-01215-06	Package Assembly (Not Shown)	25	6
37-01215-06	Package Assembly (Not Shown)	51	5
37-01215-06	Package Assembly (Not Shown)	53	5
54-10091-XX	Module, RF72 Drive	15	9
54-18316-XX	Module, RF71 Drive	14	9
54-18329-01	Module, RF31 Drive	2	9
54-18329-02	Module, RF31F Drive	3	8
54-19089-01	Module, TF85	23	7
54-19089-01	Module, TF85/TF86	25	7
54-19110-XX	Module, RZ73 Drive	35	6
54-19119-XX	Module, RF73 Drive	16	9
54-19787-01	Module, DSSI Interface Card	18	6
54-19787-01	Module, DSSI Interface Card	22	4
54-19787-01	Module, DSSI Interface Card	4	5
54-19787-02	Module, Interface Card	26	5
54-19787-02	Module, Interface Card	24	5
54-19787-03	Module, Paddle	7	3
54-19787-03	Module, Paddle	10	3
54-19787-03	Module, Paddle	13	3
54-19791-01	Module, DSSI Front Panel	27	9
54-20136-01	Module, SCSI Interface Card	34	5
54-20136-01	Module, SCSI Interface Card	37	5
54-20136-02	Module, Interface Card	63	5
54-20136-02	Module, Interface Card	65	5
54-20136-03	Module, SCSI Interface Card	47	5
54-20136-04	Module, SCSI Interface	52	8
54-20136-05	Module, SCSI Interface	54	8
54-20336-01	Module, Device ID Panel	29	7
54-20400-01	Module, SCSI Device ID Panel	55	8

INDEX BY DIGITAL PART NUMBER
400 SERIES MASS STORAGE DEVICES

PART NO.	DESCRIPTION	FIG NO.	ITEM NO.
54-20438-01	Module, RDAT ID	57	6
54-20438-01	Module, RDAT ID	58	6
54-20438-01	Module, RDAT ID	60	7
54-21530-01	Module, DSSI Remote Front Panel	28	2
54-21530-01	Module, DSSI Remote Front Panel	56	2
54-21547-01	Module, CD-ROM ID	59	4
54-23320-01	Module, SCSI Interface	45	5
54-23320-02	Module, SCSI Interface	40	6
54-23320-02	Module, SCSI Interface	43	6
54-23320-03	Module, SCSI Interface	50	4
70-02152-03	Cable Assembly, 50 Cond Molded Micro-D (BC21M-09)	1	3
70-22839-01	MOUNTING ASSEMBLY, TK50 ISE	62	1
70-22839-01	MOUNTING ASSEMBLY, TK50 ISE	63	N/A
70-22863-01	DRIVE ASSEMBLY, BA400, SCSI	41	1
70-22863-01	DRIVE ASSEMBLY, BA400, SCSI (RZ26L)	43	N/A
70-22863-02	DRIVE ASSEMBLY, BA400, SCSI	42	1
70-22863-02	DRIVE ASSEMBLY, BA400, SCSI (RZ262)	43	N/A
70-22863-03	DRIVE ASSEMBLY, BA400, SCSI	38	1
70-22863-03	DRIVE ASSEMBLY, BA400, SCSI (RZ28)	40	N/A
70-22863-04	DRIVE ASSEMBLY, BA400, SCSI	39	1
70-22863-04	DRIVE ASSEMBLY, BA400, SCSI (RZ282)	40	N/A
70-22864-01	MOUNTING ASSEMBLY, RRD43 ISE	44	1
70-22864-01	MOUNTING ASSEMBLY, RRD43 ISE	45	N/A
70-22865-01	BEZEL ASSEMBLY, CD-ROM, (BA400)	57	N/A
70-22865-01	Bezel Assembly, BA400, RRD43	57	5
70-22865-02	BEZEL ASSEMBLY, BA400, RRD43	44	2
70-22865-02	BEZEL ASSEMBLY, CD-ROM, (BA400)	57	N/A
70-22866-01	MOUNTING ASSEMBLY, BA400 DUAL SCSI	50	N/A
70-22866-01	MOUNTING ASSEMBLY, BA400, DUAL SCSI	48	1
70-22866-02	MOUNTING ASSEMBLY, BA400 DUAL SCSI	50	N/A
70-22866-02	MOUNTING ASSEMBLY, BA400, DUAL SCSI	49	1
70-23557-01	Mechanics Assembly, RF71	14	11
70-24697-01	Mechanics Assembly, RF31	2	11
70-24697-01	Mechanics Assembly, RF31F	3	10
70-25972-01	Mechanics Assembly, RF72	15	11
70-27049-01	BEZEL ASSEMBLY, DISK DRIVE	27	1
70-27049-03	BEZEL ASSEMBLY, DISK DRIVE	55	1
70-27049-04	BEZEL ASSEMBLY, 5 1/4 INCH DISK DRIVE	14	2
70-27049-04	BEZEL ASSEMBLY, 5 1/4 INCH DISK DRIVE	16	2
70-27049-04	BEZEL ASSEMBLY, 5 1/4 INCH DSSI DISK DRIVE	15	2
70-27049-04	BEZEL ASSEMBLY, 5 1/4 INCH DSSI DISK DRIVE	2	2
70-27049-04	BEZEL ASSEMBLY, 5 1/4 INCH DSSI DISK DRIVE	27	N/A
70-27049-04	BEZEL ASSEMBLY, 5 1/4 INCH DSSI DISK DRIVE	3	2
70-27049-04	BEZEL ASSEMBLY, DISK DRIVE	17	2
70-27049-04	Bezel Assembly	19	2
70-27049-04	Bezel Assembly	20	2
70-27049-04	Bezel Assembly	21	2
70-27049-05	BEZEL ASSEMBLY, 5 1/4 INCH DISK DRIVE	35	2
70-27049-05	BEZEL ASSEMBLY, 5 1/4 INCH DISK DRIVE	36	2
70-27049-05	BEZEL ASSEMBLY, DISK DRIVE	31	2
70-27049-05	BEZEL ASSEMBLY, DISK DRIVE	32	2
70-27049-05	BEZEL ASSEMBLY, DISK DRIVE	33	2
70-27049-05	BEZEL ASSEMBLY, DISK DRIVE	55	N/A
70-27050-01	BEZEL ASSEMBLY, TAPE DRIVE	29	1

INDEX BY DIGITAL PART NUMBER
400 SERIES MASS STORAGE DEVICES

PART NO.	DESCRIPTION	FIG NO.	ITEM NO.
70-27050-01	BEZEL ASSEMBLY, TAPE DRIVE	60	1
70-27050-02	BEZEL ASSEMBLY, TAPE DRIVE	61	1
70-27050-02	BEZEL ASSEMBLY, TAPE DRIVE	62	2
70-27050-02	BEZEL ASSEMBLY, TAPE DRIVE	64	2
70-27050-02	BEZEL ASSEMBLY, TAPE DRIVE	66	N/A
70-27050-03	BEZEL ASSEMBLY, TAPE DRIVE	23	2
70-27050-03	BEZEL ASSEMBLY, TAPE DRIVE	25	2
70-27050-03	BEZEL ASSEMBLY, TAPE DRIVE	29	N/A
70-27050-04	BEZEL ASSEMBLY, TAPE DRIVE	51	2
70-27050-04	BEZEL ASSEMBLY, TAPE DRIVE	53	2
70-27050-04	BEZEL ASSEMBLY, TAPE DRIVE	60	N/A
70-27412-01	Bracket Assembly, Bottom Drive	18	3
70-27412-01	Bracket Assembly, Bottom Drive	37	2
70-27413-01	Bracket Assembly, Bottom Tape Drive	24	2
70-27413-01	Bracket Assembly, Bottom Tape Drive	26	2
70-27413-01	Bracket Assembly, Bottom Tape Drive	52	1
70-27413-01	Bracket Assembly, Bottom Tape Drive	54	1
70-27413-01	Bracket Assembly, Bottom Tape Drive	63	2
70-27413-01	Bracket Assembly, Bottom Tape Drive	65	2
70-27414-01	Bezel Assembly, Filler	1	2
70-27414-01	Bezel Assembly, Filler	30	2
70-27457-01	Bracket Assembly, Top Tape Drive	24	3
70-27457-01	Bracket Assembly, Top Tape Drive	26	3
70-27457-01	Bracket Assembly, Top Tape Drive	52	2
70-27457-01	Bracket Assembly, Top Tape Drive	54	2
70-27457-01	Bracket Assembly, Top Tape Drive	63	3
70-27457-01	Bracket Assembly, Top Tape Drive	65	3
70-27458-01	Cable Assembly, Internal DSSI	1	1
70-27459-01	Cable Assembly, Internal SCSI	30	1
70-27469-01	Bracket Assembly, Bottom Drive	4	2
70-28076-01	Bracket Assembly, Bottom Drive	34	2
70-28077-01	Bracket, Top	47	3
70-28078-01	Bracket Assembly, Bottom	47	2
70-28081-01	Bezel Assembly, Wide Window	58	1
70-28081-03	BEZEL ASSEMBLY, WIDE WINDOW	46	2
70-28081-03	BEZEL ASSEMBLY, WIDE WINDOW	58	N/A
70-28086-01	MOUNTING ASSEMBLY, RF31E ISE	2	1
70-28086-01	MOUNTING ASSEMBLY, RF31E ISE	4	N/A
70-28086-02	MOUNTING ASSEMBLY, RF31F ISE	3	1
70-28086-02	MOUNTING ASSEMBLY, RF31F ISE	4	N/A
70-28087-01	MOUNTING ASSEMBLY, RF71 ISE	14	1
70-28087-01	MOUNTING ASSEMBLY, RF71 ISE	18	N/A
70-28087-02	MOUNTING ASSEMBLY, RF72 ISE	15	1
70-28087-02	MOUNTING ASSEMBLY, RF72 ISE	18	N/A
70-28087-03	MOUNTING ASSEMBLY, RF73 ISE	16	1
70-28087-03	MOUNTING ASSEMBLY, RF73 ISE (added)	18	N/A
70-28087-05	MOUNTING ASSEMBLY, RF74 ISE	17	1
70-28087-05	MOUNTING ASSEMBLY, RF74 ISE (added)	18	N/A
70-28088-01	MOUNTING ASSEMBLY, TK70 ISE	64	1
70-28088-01	MOUNTING ASSEMBLY, TK70 ISE	65	N/A
70-28089-01	MOUNTING ASSEMBLY, RZ56 ISE	31	1
70-28089-01	MOUNTING ASSEMBLY, RZ56 ISE	34	N/A
70-28089-02	MOUNTING ASSEMBLY, RZ57 ISE	32	1
70-28089-02	MOUNTING ASSEMBLY, RZ57 ISE	34	N/A

INDEX BY DIGITAL PART NUMBER
400 SERIES MASS STORAGE DEVICES

PART NO.	DESCRIPTION	FIG NO.	ITEM NO.
70-28089-03	MOUNTING ASSEMBLY, RZ58 ISE	33	1
70-28089-03	MOUNTING ASSEMBLY, RZ58 ISE (added)	34	N/A
70-28089-04	MOUNTING ASSEMBLY, RZ73 ISE	35	1
70-28089-04	MOUNTING ASSEMBLY, RZ73 ISE	37	N/A
70-28089-05	MOUNTING ASSEMBLY, RZ74 ISE	36	1
70-28089-05	MOUNTING ASSEMBLY, RZ74 ISE	37	N/A
70-28090-01	MOUNTING ASSEMBLY, TLZ04 ISE	46	1
70-28090-01	MOUNTING ASSEMBLY, TLZ04 ISE	47	N/A
70-28092-01	MOUNTING ASSEMBLY, TF85 ISE	23	1
70-28092-01	MOUNTING ASSEMBLY, TF85 ISE	24	N/A
70-28092-03	MOUNTING ASSEMBLY, TF86 ISE	25	1
70-28092-03	MOUNTING ASSEMBLY, TF86 ISE	26	N/A
70-28092-04	MOUNTING ASSEMBLY, TK85 ISE	51	1
70-28092-04	MOUNTING ASSEMBLY, TZ86	52	N/A
70-28092-05	MOUNTING ASSEMBLY, TK85 ISE	53	1
70-28092-05	MOUNTING ASSEMBLY, TZ87	54	N/A
70-28814-01	Mechanics Assembly, RF73	16	11
70-29475-01	MOUNTING ASSEMBLY, RF35 ISE	10	N/A
70-29475-01	MOUNTING ASSEMBLY, RF35 ISE	8	1
70-29475-02	MOUNTING ASSEMBLY, RF35 ISE DUAL	10	N/A
70-29475-02	MOUNTING ASSEMBLY, RF35 ISE DUAL	9	1
70-29475-03	MOUNTING ASSEMBLY, RF31T ISE	5	1
70-29475-03	MOUNTING ASSEMBLY, RF31T ISE	7	N/A
70-29475-04	MOUNTING ASSEMBLY, RF312 ISE DUAL	7	N/A
70-29475-04	MOUNTING ASSEMBLY, RF35 ISE DUAL	6	1
70-29475-05	MOUNTING ASSEMBLY, RF36 ISE	11	1
70-29475-05	MOUNTING ASSEMBLY, RF36 ISE (added)	13	N/A
70-29475-06	MOUNTING ASSEMBLY, RF36 ISE DUAL	12	1
70-29475-06	MOUNTING ASSEMBLY, RF36 ISE DUAL (added)	13	N/A
70-29476-01	Bracket Assembly, Bottom Drive	10	11
70-29476-01	Bracket Assembly, Bottom Drive	13	11
70-29476-01	Bracket Assembly, Bottom Drive	7	11
70-29478-01	BEZEL ASSEMBLY, 3 1/2 INCH DSSI DISK DRIVE	28	N/A
70-29478-02	BEZEL ASSEMBLY, 3 1/2 INCH DSSI DISK DRIVE	11	2
70-29478-02	BEZEL ASSEMBLY, 3 1/2 INCH DSSI DISK DRIVE	12	2
70-29478-02	BEZEL ASSEMBLY, 3 1/2 INCH DSSI DISK DRIVE	38	2
70-29478-02	BEZEL ASSEMBLY, 3 1/2 INCH DSSI DISK DRIVE	39	2
70-29478-02	BEZEL ASSEMBLY, 3 1/2 INCH DSSI DISK DRIVE	41	2
70-29478-02	BEZEL ASSEMBLY, 3 1/2 INCH DSSI DISK DRIVE	42	2
70-29478-02	BEZEL ASSEMBLY, 3 1/2 INCH DSSI DISK DRIVE	5	2
70-29478-02	BEZEL ASSEMBLY, 3 1/2 INCH DSSI DISK DRIVE	56	N/A
70-29478-02	BEZEL ASSEMBLY, 3 1/2 INCH DSSI DISK DRIVE	6	2
70-29478-02	BEZEL ASSEMBLY, 3 1/2 INCH DSSI DISK DRIVE	8	2
70-29478-02	BEZEL ASSEMBLY, 3 1/2 INCH DSSI DISK DRIVE	9	2
70-29547-01	BEZEL/PCB ASSEMBLY, REMOVABLE MEDIA	48	2
70-29547-01	BEZEL/PCB ASSEMBLY, REMOVABLE MEDIA	49	2
70-29547-01	BEZEL/PCB ASSEMBLY, REMOVABLE MEDIA	59	N/A
70-29547-02	BEZEL/PCB ASSEMBLY, REMOVABLE MEDIA	59	N/A
70-29547-02	Bezel Assembly	59	1
70-29868-01	Disk Drive Assembly, SSD, 100 MB w/Data Retention	19	1
70-29868-01	Disk Drive Assembly, SSD, 100 MB w/Data Retention	22	1
70-29868-03	Disk Drive Assembly, SSD, 200 MB w/Data Retention	20	1
70-29868-03	Disk Drive Assembly, SSD, 200 MB w/Data Retention	22	1
70-29869-01	Disk Drive Assembly, SSD, 250 MB	21	1

INDEX BY DIGITAL PART NUMBER
400 SERIES MASS STORAGE DEVICES

PART NO.	DESCRIPTION	FIG NO.	ITEM NO.
70-29869-01	Disk Drive Assembly, SSD, 250 MB	22	1
70-30268-01	Bracket Assembly, Top Drive	22	2
70-30269-01	Bracket Assembly, Bottom Drive	22	3
74-25652-02	Plate, Skid	19	8
74-25652-02	Plate, Skid	20	8
74-25652-02	Plate, Skid	21	8
74-33507-01	Panel, Blank Dual	61	11
74-33507-01	Panel, Blank Dual	61	5
74-38828-01	Bracket Assembly, Top Drive	18	4
74-38828-01	Bracket, Top SCSI	37	3
74-38830-01	Bracket, Paddle Board	18	5
74-38830-01	Bracket, Paddle Board	22	5
74-38830-01	Bracket, Paddle Board	24	4
74-38830-01	Bracket, Paddle Board	26	4
74-38830-01	Bracket, Paddle Board	34	4
74-38830-01	Bracket, Paddle Board	37	4
74-38830-01	Bracket, Paddle Board	4	4
74-38830-01	Bracket, Paddle Board	45	4
74-38830-01	Bracket, Paddle Board	47	4
74-38830-01	Bracket, Paddle Board	50	3
74-38830-01	Bracket, Paddle Board	63	4
74-38830-01	Bracket, Paddle Board	65	4
74-38830-01	Bracket, Paddle Module	10	14
74-38830-01	Bracket, Paddle Module	13	14
74-38830-01	Bracket, Paddle Module	40	5
74-38830-01	Bracket, Paddle Module	43	5
74-38830-01	Bracket, Paddle Module	52	3
74-38830-01	Bracket, Paddle Module	54	3
74-38830-01	Bracket, Paddle Module	7	14
74-39272-01	Bezel, RF71 Drive	27	2
74-39272-03	Bezel, Drive	55	2
74-39273-01	Bezel, Tape Drive	29	2
74-39273-01	Bezel, Tape Drive	60	2
74-39273-01	Bezel, Tape Drive	66	1
74-40846-01	Bracket Assembly, Top Drive	4	3
74-41144-01	Bracket, Top SCSI	34	3
74-41159-01	Bezel, Wide Window	58	2
74-44060-01	Bezel, Removable Media, Dual	59	5
74-44062-01	Panel, Blank Filler	48	8
74-44231-01	Bracket Assembly, Top Drive	10	1
74-44231-01	Bracket Assembly, Top Drive	13	1
74-44231-01	Bracket Assembly, Top Drive	7	1
74-44233-01	Plate, Top Bracket Adapter	10	4
74-44233-01	Plate, Top Bracket Adapter	13	4
74-44233-01	Plate, Top Bracket Adapter	40	3
74-44233-01	Plate, Top Bracket Adapter	43	3
74-44233-01	Plate, Top Bracket Adapter	7	4
74-44234-01	Plate, Bottom Bracket Adapter	10	10
74-44234-01	Plate, Bottom Bracket Adapter	13	10
74-44234-01	Plate, Bottom Bracket Adapter	40	4
74-44234-01	Plate, Bottom Bracket Adapter	43	4
74-44234-01	Plate, Bottom Bracket Adapter	7	10
74-44325-01	Bezel, Blank	28	1
74-44325-01	Bezel, Blank	56	1

INDEX BY DIGITAL PART NUMBER
400 SERIES MASS STORAGE DEVICES

PART NO.	DESCRIPTION	FIG NO.	ITEM NO.
74-48669-01	Bracket Assembly, Bottom	50	2
74-48670-01	Bracket Assembly, Top	50	1
74-48671-01	Bracket Assembly, Bottom	45	2
74-48672-01	Bracket Assembly, Top	45	3
74-48673-01	Bezel, RRD43	57	1
74-48767-01	Bracket Assembly, Bottom Drive	40	1
74-48767-01	Bracket Assembly, Bottom Drive	43	1
74-48768-01	Bracket Assembly, Top Drive	40	2
74-48768-01	Bracket Assembly, Top Drive	43	2
90-06011-01	Screw, Mach Phi Pan Hd No. 4-40 x 3/8	35	7
90-06011-01	Screw, Machine Phi Pan Hd No. 4-40 x 3/8	14	10
90-06011-01	Screw, Machine Phi Pan Hd No. 4-40 x 3/8	15	10
90-06011-01	Screw, Machine Phi Pan Hd No. 4-40 x 3/8	16	10
90-06011-01	Screw, Machine Phi Pan Hd No. 4-40 x 3/8	2	10
90-06011-01	Screw, Machine Phi Pan Hd No. 4-40 x 3/8	3	9
90-06020-01	Screw, Mach Pan Hd No. 6-32 x 1/4	19	9
90-06020-01	Screw, Mach Pan Hd No. 6-32 x 1/4	20	9
90-06020-01	Screw, Mach Pan Hd No. 6-32 x 1/4	21	9
90-06020-01	Screw, Mach Pan Hd No. 6-32 x 1/4	57	8
90-06021-01	Screw, Mach Pan Hd No. 6-32 x 5/16	59	6
90-06021-01	Screw, Machine Phi Pan Hd No. 6-32 x 5/16	58	5
90-06021-01	Screw, Phi Pan Hd No. 6-32 x 5/16	27	5
90-06021-01	Screw, Phi Pan Hd No. 6-32 x 5/16	29	5
90-06021-01	Screw, Phi Pan Hd No. 6-32 x 5/16	55	5
90-06021-01	Screw, Phi Pan Hd No. 6-32 x 5/16	60	5
90-06021-01	Screw, Phi Pan Hd No. 6-32 x 5/16	66	4
90-06024-02	Screw, Machine Phi Pan Hd No. 6-32 x 1/2 (deleted)	18	8
90-06024-02	Screw, Machine Phi Pan Hd No. 6-32 x 1/2 (deleted)	4	7
90-06025-02	Screw, Mach Flat Hd No. 6-32 x 5/8	22	9
90-06025-02	Screw, Mach Flat Hd No. 6-32 x 5/8	52	6
90-06025-02	Screw, Mach Flat Hd No. 6-32 x 5/8	54	6
90-06025-02	Screw, Machine Flat Hd No. 6-32 x 5/8	10	6
90-06025-02	Screw, Machine Flat Hd No. 6-32 x 5/8	13	6
90-06025-02	Screw, Machine Flat Hd No. 6-32 x 5/8	24	7
90-06025-02	Screw, Machine Flat Hd No. 6-32 x 5/8	26	7
90-06025-02	Screw, Machine Flat Hd No. 6-32 x 5/8	40	12
90-06025-02	Screw, Machine Flat Hd No. 6-32 x 5/8	43	12
90-06025-02	Screw, Machine Flat Hd No. 6-32 x 5/8	63	7
90-06025-02	Screw, Machine Flat Hd No. 6-32 x 5/8	65	7
90-06025-02	Screw, Machine Flat Hd No. 6-32 x 5/8	7	6
90-06025-02	Screw, Machine Flat Hd No. 6-32 x 5/8 (deleted)	18	9
90-06025-02	Screw, Machine Flat Hd No. 6-32 x 5/8 (deleted)	4	8
90-09315-01	Screw, Phi Pan Hd No. 4-40 x 1/4	10	12
90-09315-01	Screw, Phi Pan Hd No. 4-40 x 1/4	13	12
90-09315-01	Screw, Phi Pan Hd No. 4-40 x 1/4	18	10
90-09315-01	Screw, Phi Pan Hd No. 4-40 x 1/4	22	10
90-09315-01	Screw, Phi Pan Hd No. 4-40 x 1/4	24	8
90-09315-01	Screw, Phi Pan Hd No. 4-40 x 1/4	26	8
90-09315-01	Screw, Phi Pan Hd No. 4-40 x 1/4	34	8
90-09315-01	Screw, Phi Pan Hd No. 4-40 x 1/4	37	8
90-09315-01	Screw, Phi Pan Hd No. 4-40 x 1/4	4	9
90-09315-01	Screw, Phi Pan Hd No. 4-40 x 1/4	40	11
90-09315-01	Screw, Phi Pan Hd No. 4-40 x 1/4	43	11
90-09315-01	Screw, Phi Pan Hd No. 4-40 x 1/4	45	10

INDEX BY DIGITAL PART NUMBER
400 SERIES MASS STORAGE DEVICES

PART NO.	DESCRIPTION	FIG NO.	ITEM NO.
90-09315-01	Screw, Phi Pan Hd No. 4-40 x 1/4	47	8
90-09315-01	Screw, Phi Pan Hd No. 4-40 x 1/4	50	10
90-09315-01	Screw, Phi Pan Hd No. 4-40 x 1/4	52	7
90-09315-01	Screw, Phi Pan Hd No. 4-40 x 1/4	54	7
90-09315-01	Screw, Phi Pan Hd No. 4-40 x 1/4	63	8
90-09315-01	Screw, Phi Pan Hd No. 4-40 x 1/4	65	8
90-09315-01	Screw, Phi Pan Hd No. 4-40 x 1/4	7	12
90-10174-00	Screw, Sems Phi Hd No. 6-32 x 1/4	10	8
90-10174-00	Screw, Sems Phi Hd No. 6-32 x 1/4	13	8
90-10174-00	Screw, Sems Phi Hd No. 6-32 x 1/4	40	10
90-10174-00	Screw, Sems Phi Hd No. 6-32 x 1/4	43	10
90-10174-00	Screw, Sems Phi Hd No. 6-32 x 1/4	7	8
90-10971-01	Screw, Mach Truss Hd No. 6-32 x 1/4	57	4
90-11163-01	Screw, Machine No. M-3 14 mm	47	7
90-40122-04	Screw, Mach M3 Flat Hd	45	9
90-40122-04	Screw, Mach M3 Flat Hd	50	9
EK-BA44A-IN	Documentation, "Storage Device Add On Procedure" Listed on several parts lists throughout the manual.		
EK-EF5XX-UG	Documentation, "EF5XX Series Solid State Disk"	19	6
EK-EF5XX-UG	Documentation, "EF5XX Series Solid State Disk"	20	62
EK-EF5XX-UG	Documentation, "EF5XX Series Solid State Disk"	21	6
EK-RRDDD-IN	Documentation, "RRD43 CD-ROM Disk Drive Information"	44	4
KZQSA-SA	Module, KZQSA	30	3
M7546-00	Module, Tape Controller	61	9
M7559-00	Module, Tape Controller	61	3
QA-MT1AA-UP	Kit, OVMA VAX/AXP	48	5
QA-MT1AA-UP	Kit, OVMA VAX/AXP	49	5
RF31-EA	Disk Drive Assembly RF31E	4	1
RF31F-EA	Disk Drive Assembly RF31F	4	1
RF31T-EA	Storage Element, RF31T	7	9
RF35-EA	Storage Element, RF35E	10	9
RF36-EA	Storage Element, RF36E	13	9
RF71-EA	Disk Drive Assembly (RF71)	18	1
RF72-EA	Disk Drive Assembly (RF72)	18	1
RF73-EA	Disk Drive Assembly (RF73) (added)	18	1
RF74-EA	Disk Drive Assembly (RF74) (added)	18	1
RRD43-AA	CD-ROM Drive Assembly, Half Height, Dual Speed, 5 1/4 Inch SCSI, 600 MB	50	11
RRD43-AB	CD-ROM Drive Assembly, 1 Inch High, Dual Speed, 5 1/4 Inch SCSI, 600 MB	45	1
RZ26L	Storage Element, RZ26L	43	13
RZ28E	Storage Element, RZ28E	40	13
RZ56-E	Disk Drive Assembly	34	1
RZ57-E	Disk Drive Assembly	34	1
RZ58-E	Disk Drive Assembly (added)	34	1
RZ73-E	Disk Drive Assembly	37	1
RZ73E	STORAGE ELEMENT, RZ73E	35	N/A
RZ74-E	Disk Drive Assembly	37	1
RZ74E	STORAGE ELEMENT, RZ74E	36	N/A

INDEX BY DIGITAL PART NUMBER
400 SERIES MASS STORAGE DEVICES

PART NO.	DESCRIPTION	FIG NO.	ITEM NO.
TF85-B A	Tape Drive Assembly	24	1
TF86-B A	Tape Drive Assembly	26	1
TK50-E A	Tape Drive Assembly	63	1
TK50E-AA	TK50E Tape Drive Assembly	61	14
TK50E-AF	TK50E Tape Drive Assembly	61	14
TK70-E A	Tape Drive Assembly	65	1
TK70E-AA	TK70E Tape Drive Assembly	61	14
TK70E-AF	TK70E Tape Drive Assembly	61	14
TK85-BX	Mechanics Assembly, TF85	23	8
TK86-BX	Mechanics Assembly, TF86	25	8
TLZ04-AA	Tape Drive Assembly	47	1
TLZ04-HA	Cartridge, Cleaning	48	6
TLZ04-HA	Cartridge, Cleaning	49	6
TLZ07-B A	Tape Drive Assembly, Half Height, 5 1/4 Inch, 8 GB, 4MM	50	12
TLZ07-C A	Cartridge, Single 4 MM, 4 GB	48	7
TLZ07-C A	Cartridge, Single 4 MM, 4 GB	49	7
TQK50-S A	KIT, Q-bus CONTROLLER	61	8
TQK70-S A	KIT, Q-bus CONTROLLER	61	2
TZ86-B A	Tape Drive Assembly, TK86-BX	52	10
TZ87-B A	Tape Drive Assembly, SCSI, 20 GB	54	10

**INDEX BY DIGITAL PART NUMBER
400 SERIES MASS STORAGE DEVICES**

PART NO.	DESCRIPTION	FIG NO.	ITEM NO.
---------------------	--------------------	--------------------	---------------------

THIS PAGE INTENTIONALLY LEFT BLANK

INDEX BY DIGITAL PART DESCRIPTION
400 SERIES MASS STORAGE DEVICES

DESCRIPTION	PART NO.	FIG. NO.	ITEM NO.
Battery Pack	12-19245-01	22	6
BEZEL ASSEMBLY, 3 1/2 INCH DSSI DISK DRIVE	70-29478-01	28	N/A
BEZEL ASSEMBLY, 3 1/2 INCH DSSI DISK DRIVE	70-29478-02	11	2
BEZEL ASSEMBLY, 3 1/2 INCH DSSI DISK DRIVE	70-29478-02	12	2
BEZEL ASSEMBLY, 3 1/2 INCH DSSI DISK DRIVE	70-29478-02	38	2
BEZEL ASSEMBLY, 3 1/2 INCH DSSI DISK DRIVE	70-29478-02	39	2
BEZEL ASSEMBLY, 3 1/2 INCH DSSI DISK DRIVE	70-29478-02	41	2
BEZEL ASSEMBLY, 3 1/2 INCH DSSI DISK DRIVE	70-29478-02	42	2
BEZEL ASSEMBLY, 3 1/2 INCH DSSI DISK DRIVE	70-29478-02	5	2
BEZEL ASSEMBLY, 3 1/2 INCH DSSI DISK DRIVE	70-29478-02	56	N/A
BEZEL ASSEMBLY, 3 1/2 INCH DSSI DISK DRIVE	70-29478-02	6	2
BEZEL ASSEMBLY, 3 1/2 INCH DSSI DISK DRIVE	70-29478-02	8	2
BEZEL ASSEMBLY, 3 1/2 INCH DSSI DISK DRIVE	70-29478-02	9	2
BEZEL ASSEMBLY, 5 1/4 INCH DISK DRIVE	70-27049-04	14	2
BEZEL ASSEMBLY, 5 1/4 INCH DISK DRIVE	70-27049-04	16	2
BEZEL ASSEMBLY, 5 1/4 INCH DISK DRIVE	70-27049-05	35	2
BEZEL ASSEMBLY, 5 1/4 INCH DISK DRIVE	70-27049-05	36	2
BEZEL ASSEMBLY, 5 1/4 INCH DSSI DISK DRIVE	70-27049-04	15	2
BEZEL ASSEMBLY, 5 1/4 INCH DSSI DISK DRIVE	70-27049-04	2	2
BEZEL ASSEMBLY, 5 1/4 INCH DSSI DISK DRIVE	70-27049-04	27	N/A
BEZEL ASSEMBLY, 5 1/4 INCH DSSI DISK DRIVE	70-27049-04	3	2
Bezel Assembly	70-27049-04	19	2
Bezel Assembly	70-27049-04	20	2
Bezel Assembly	70-27049-04	21	2
Bezel Assembly	70-29547-02	59	1
Bezel Assembly, BA400, RRD43	70-22865-01	57	5
BEZEL ASSEMBLY, BA400, RRD43	70-22865-02	44	2
BEZEL ASSEMBLY, CD-ROM, (BA400)	70-22865-01	57	N/A
BEZEL ASSEMBLY, CD-ROM, (BA400)	70-22865-02	57	N/A
BEZEL ASSEMBLY, DISK DRIVE	70-27049-01	27	1
BEZEL ASSEMBLY, DISK DRIVE	70-27049-03	55	1
BEZEL ASSEMBLY, DISK DRIVE	70-27049-04	17	2
BEZEL ASSEMBLY, DISK DRIVE	70-27049-05	31	2
BEZEL ASSEMBLY, DISK DRIVE	70-27049-05	32	2
BEZEL ASSEMBLY, DISK DRIVE	70-27049-05	33	2
BEZEL ASSEMBLY, DISK DRIVE	70-27049-05	55	N/A
Bezel Assembly, Filler	70-27414-01	1	2
Bezel Assembly, Filler	70-27414-01	30	2
BEZEL ASSEMBLY, TAPE DRIVE	70-27050-01	29	1
BEZEL ASSEMBLY, TAPE DRIVE	70-27050-01	60	1
BEZEL ASSEMBLY, TAPE DRIVE	70-27050-02	61	1
BEZEL ASSEMBLY, TAPE DRIVE	70-27050-02	62	2
BEZEL ASSEMBLY, TAPE DRIVE	70-27050-02	64	2
BEZEL ASSEMBLY, TAPE DRIVE	70-27050-02	66	N/A
BEZEL ASSEMBLY, TAPE DRIVE	70-27050-03	23	2
BEZEL ASSEMBLY, TAPE DRIVE	70-27050-03	25	2
BEZEL ASSEMBLY, TAPE DRIVE	70-27050-03	29	N/A
BEZEL ASSEMBLY, TAPE DRIVE	70-27050-04	51	2
BEZEL ASSEMBLY, TAPE DRIVE	70-27050-04	53	2
BEZEL ASSEMBLY, TAPE DRIVE	70-27050-04	60	N/A
BEZEL ASSEMBLY, WIDE WINDOW	70-28081-03	46	2
BEZEL ASSEMBLY, WIDE WINDOW	70-28081-03	58	N/A
Bezel Assembly, Wide Window	70-28081-01	58	1

INDEX BY DIGITAL PART DESCRIPTION
400 SERIES MASS STORAGE DEVICES

DESCRIPTION	PART NO.	FIG. NO.	ITEM NO.
Bezel, Blank	74-44325-01	28	1
Bezel, Blank	74-44325-01	56	1
Bezel, Drive	74-39272-03	55	2
BEZEL/PCB ASSEMBLY, REMOVABLE MEDIA	70-29547-01	49	2
BEZEL/PCB ASSEMBLY, REMOVABLE MEDIA	70-29547-01	48	2
BEZEL/PCB ASSEMBLY, REMOVABLE MEDIA	70-29547-01	59	N/A
BEZEL/PCB ASSEMBLY, REMOVABLE MEDIA	70-29547-02	59	N/A
Bezel, RF71 Drive	74-39272-01	27	2
Bezel, RRD43	74-48673-01	57	1
Bezel, Removable Media, Dual	74-44060-01	59	5
Bezel, Tape Drive	74-39273-01	29	2
Bezel, Tape Drive	74-39273-01	60	2
Bezel, Tape Drive	74-39273-01	66	1
Bezel, Wide Window	74-41159-01	58	2
Bracket Assembly, Bottom	70-28078-01	47	2
Bracket Assembly, Bottom	74-48669-01	50	2
Bracket Assembly, Bottom	74-48671-01	45	2
Bracket Assembly, Bottom Drive	70-27412-01	18	3
Bracket Assembly, Bottom Drive	70-27412-01	37	2
Bracket Assembly, Bottom Drive	70-27469-01	4	2
Bracket Assembly, Bottom Drive	70-28076-01	34	2
Bracket Assembly, Bottom Drive	70-29476-01	10	11
Bracket Assembly, Bottom Drive	70-29476-01	13	11
Bracket Assembly, Bottom Drive	70-29476-01	7	11
Bracket Assembly, Bottom Drive	70-30269-01	22	3
Bracket Assembly, Bottom Drive	74-48767-01	40	1
Bracket Assembly, Bottom Drive	74-48767-01	43	1
Bracket Assembly, Bottom Tape Drive	70-27413-01	24	2
Bracket Assembly, Bottom Tape Drive	70-27413-01	26	2
Bracket Assembly, Bottom Tape Drive	70-27413-01	52	1
Bracket Assembly, Bottom Tape Drive	70-27413-01	54	1
Bracket Assembly, Bottom Tape Drive	70-27413-01	63	2
Bracket Assembly, Bottom Tape Drive	70-27413-01	65	2
Bracket Assembly, Top	74-48670-01	50	1
Bracket Assembly, Top	74-48672-01	45	3
Bracket Assembly, Top Drive	70-30268-01	22	2
Bracket Assembly, Top Drive	74-38828-01	18	4
Bracket Assembly, Top Drive	74-40846-01	4	3
Bracket Assembly, Top Drive	74-44231-01	10	1
Bracket Assembly, Top Drive	74-44231-01	13	1
Bracket Assembly, Top Drive	74-44231-01	7	1
Bracket Assembly, Top Drive	74-48768-01	40	2
Bracket Assembly, Top Drive	74-48768-01	43	2
Bracket Assembly, Top Tape Drive	70-27457-01	24	3
Bracket Assembly, Top Tape Drive	70-27457-01	26	3
Bracket Assembly, Top Tape Drive	70-27457-01	52	2
Bracket Assembly, Top Tape Drive	70-27457-01	54	2
Bracket Assembly, Top Tape Drive	70-27457-01	63	3
Bracket Assembly, Top Tape Drive	70-27457-01	65	3
Bracket, Paddle Board	74-38830-01	18	5
Bracket, Paddle Board	74-38830-01	22	5
Bracket, Paddle Board	74-38830-01	24	4
Bracket, Paddle Board	74-38830-01	26	4
Bracket, Paddle Board	74-38830-01	34	4

INDEX BY DIGITAL PART DESCRIPTION
400 SERIES MASS STORAGE DEVICES

DESCRIPTION	PART NO.	FIG. NO.	ITEM NO.
Bracket, Paddle Board	74-38830-01	37	4
Bracket, Paddle Board	74-38830-01	4	4
Bracket, Paddle Board	74-38830-01	45	4
Bracket, Paddle Board	74-38830-01	47	4
Bracket, Paddle Board	74-38830-01	50	3
Bracket, Paddle Board	74-38830-01	63	4
Bracket, Paddle Board	74-38830-01	65	4
Bracket, Paddle Module	74-38830-01	10	14
Bracket, Paddle Module	74-38830-01	13	14
Bracket, Paddle Module	74-38830-01	40	5
Bracket, Paddle Module	74-38830-01	43	5
Bracket, Paddle Module	74-38830-01	52	3
Bracket, Paddle Module	74-38830-01	54	3
Bracket, Paddle Module	74-38830-01	7	14
Bracket, Top	70-28077-01	47	3
Bracket, Top SCSI	74-38828-01	37	3
Bracket, Top SCSI	74-41144-01	34	3
Cable Assembly	17-01363-01	61	10
Cable Assembly	17-01363-01	61	4
Cable Assembly, 06 Cond.	17-03498-01	37	9
Cable Assembly, 10 Cond	17-02706-01	18	11
Cable Assembly, 10 Cond	17-02706-01	22	7
Cable Assembly, 10 Cond	17-02706-01	4	10
Cable Assembly, 10 Cond.	17-01936-02	47	9
Cable Assembly, 10 Cond.	17-02887-01	34	9
Cable Assembly, 50 Cond Molded Micro-D (BC21M-09)	70-02152-03	1	3
Cable Assembly, 50 Cond, Molded, Shielded	17-02659-03	30	5
Cable Assembly, 50 Cond, Molded, Shielded	17-02659-03	44	7
Cable Assembly, Flat 06 Cond.	17-04006-01	45	6
Cable Assembly, Flat 06 Cond.	17-04006-01	50	5
Cable Assembly, Flat 06 Cond., 28AWG, 6 Pos.	17-03431-01	50	6
Cable Assembly, Flat, 10 Cond	17-01936-01	54	9
Cable Assembly, Flat, 10 Cond	17-01936-06	52	9
Cable Assembly, Internal DSSI	70-27458-01	1	1
Cable Assembly, Internal SCSI	70-27459-01	30	1
Cable Assembly, RFP 7 in. Female Flat	17-03428-01	10	15
Cable Assembly, RFP 7 in. Female Flat	17-03428-01	13	15
Cable Assembly, RFP 7 in. Female Flat	17-03428-01	40	7
Cable Assembly, RFP 7 in. Female Flat	17-03428-01	43	7
Cable Assembly, RFP 7 in. Female Flat	17-03428-01	7	15
Cartridge, Cleaning	TLZ04-HA	48	6
Cartridge, Cleaning	TLZ04-HA	49	6
Cartridge, Single 4 MM, 4 GB	TLZ07-CA	48	7
Cartridge, Single 4 MM, 4 GB	TLZ07-CA	49	7
CD-ROM Drive Assembly, 1 Inch High, DualSpeed, 5 1/4 Inch SCSI, 600 MB	RRD43-AB	45	1
CD-ROM Drive Assembly, Half Height, Dual Speed, 5 1/4 Inch SCSI, 600 MB	RRD43-AA	50	11
Connector, SCSI Term 50 Pos Champ Hsg	12-30552-01	30	4
Connector, Terminator	12-29258-01	1	4
Cover, 50 Pin IDC Connector	12-33377-01	30	6
Disk Drive Assembly	RZ56-E	34	1
Disk Drive Assembly	RZ57-E	34	1

INDEX BY DIGITAL PART DESCRIPTION
400 SERIES MASS STORAGE DEVICES

DESCRIPTION	PART NO.	FIG. NO.	ITEM NO.
Disk Drive Assembly	RZ73-E	37	1
Disk Drive Assembly	RZ74-E	37	1
Disk Drive Assembly (RF71)	RF71-EA	18	1
Disk Drive Assembly (RF72)	RF72-EA	18	1
Disk Drive Assembly (RF73) (added)	RF73-EA	18	1
Disk Drive Assembly (RF74) (added)	RF74-EA	18	1
Disk Drive Assembly (added)	RZ58-E	34	1
Disk Drive Assembly RF31E	RF31-EA	4	1
Disk Drive Assembly RF31F	RF31F-EA	4	1
Disk Drive Assembly, SSD, 100 MB w/Data Retention	70-29868-01	22	1
Disk Drive Assembly, SSD, 100 MB w/Data Retention	70-29868-01	19	1
Disk Drive Assembly, SSD, 200 MB w/Data Retention	70-29868-03	20	1
Disk Drive Assembly, SSD, 200 MB w/Data Retention	70-29868-03	22	1
Disk Drive Assembly, SSD, 250 MB	70-29869-01	21	1
Disk Drive Assembly, SSD, 250 MB	70-29869-01	22	1
Documentation, "EF5XX Series Solid State Disk"	EK-EF5XX-UG	19	6
Documentation, "EF5XX Series Solid State Disk"	EK-EF5XX-UG	20	6
Documentation, "EF5XX Series Solid State Disk"	EK-EF5XX-UG	21	6
Documentation, "RRD43 CD-ROM DiskDriveInformation"	EK-RRDDD-IN	44	4
Documentation, "Storage Device Add On Procedure"	EK-BA44A-IN		
Listed on several parts lists throughout the manual.			
DRIVE ASSEMBLY, BA400, SCSI	70-22863-03	38	1
DRIVE ASSEMBLY, BA400, SCSI	70-22863-01	41	1
DRIVE ASSEMBLY, BA400, SCSI	70-22863-02	42	1
DRIVE ASSEMBLY, BA400, SCSI	70-22863-04	39	1
DRIVE ASSEMBLY, BA400, SCSI (RZ262)	70-22863-02	43	N/A
DRIVE ASSEMBLY, BA400, SCSI (RZ26L)	70-22863-01	43	N/A
DRIVE ASSEMBLY, BA400, SCSI (RZ28)	70-22863-03	40	N/A
DRIVE ASSEMBLY, BA400, SCSI (RZ282)	70-22863-04	40	N/A
Encoder Set, Lens (DSSI Unit ID Plug)	12-28766-19	22	11
Ferrule (added)	12-32626-03	47	10
Finger, Grounding	12-26922-01	27	3
Finger, Grounding	12-26922-01	29	3
Finger, Grounding	12-26922-01	55	3
Finger, Grounding	12-26922-01	57	2
Finger, Grounding	12-26922-01	58	3
Finger, Grounding	12-26922-01	59	2
Finger, Grounding	12-26922-01	60	3
Finger, Grounding	12-26922-01	66	2
Finger, Non-Snag Grounding	12-26922-01	28	3
Finger, Non-Snag Grounding	12-26922-01	56	3
Isolator, Shock Grommet (added)	12-32626-04	18	7
Isolator, Shock (Ferrule)	12-32626-03	24	6
Isolator, Shock (Ferrule)	12-32626-03	26	6
Isolator, Shock (Grommet)	12-32626-04	24	6A
Isolator, Shock (Grommet)	12-32626-04	26	6A
Isolator, Shock (deleted)	12-32626-01	18	7
Isolator, Shock (deleted)	12-32626-01	4	6
Isolator, Shock (deleted)	12-32626-01	47	6
Isolator, Shock (deleted)	12-32626-01	63	6
Isolator, Shock (deleted)	12-32626-01	65	6
Isolator, Shock Ferrule	12-32626-03	10	7
Isolator, Shock Ferrule	12-32626-03	13	7

INDEX BY DIGITAL PART DESCRIPTION
400 SERIES MASS STORAGE DEVICES

DESCRIPTION	PART NO.	FIG. NO.	ITEM NO.
Isolator, Shock Ferrule	12-32626-03	40	8
Isolator, Shock Ferrule	12-32626-03	43	8
Isolator, Shock Ferrule	12-32626-03	45	7
Isolator, Shock Ferrule	12-32626-03	50	7
Isolator, Shock Ferrule	12-32626-03	52	4
Isolator, Shock Ferrule	12-32626-03	54	4
Isolator, Shock Ferrule	12-32626-03	7	7
Isolator, Shock Ferrule Only (added)	12-32626-03	65	6
Isolator, Shock Grommet	12-32626-04	10	5
Isolator, Shock Grommet	12-32626-04	13	5
Isolator, Shock Grommet	12-32626-04	34	6
Isolator, Shock Grommet	12-32626-04	37	6
Isolator, Shock Grommet	12-32626-04	40	9
Isolator, Shock Grommet	12-32626-04	43	9
Isolator, Shock Grommet	12-32626-04	45	8
Isolator, Shock Grommet	12-32626-04	50	8
Isolator, Shock Grommet	12-32626-04	52	5
Isolator, Shock Grommet	12-32626-04	54	5
Isolator, Shock Grommet	12-32626-04	7	5
Isolator, Shock Grommet (added)	12-32626-04	4	6
Isolator, Shock Grommet (added)	12-32626-04	47	6
Isolator, Shock Grommet Only (added)	12-32626-04	63	6
Isolator, Shock Grommet Only (added)	12-32626-04	65	6
Isolator, Shock, Ferrule	12-32626-03	22	8
Isolator, Shock, Grommet	12-32626-04	22	8
KIT, Q-bus CONTROLLER	TQK50-SA	61	8
KIT, Q-bus CONTROLLER	TQK70-SA	61	2
Kit, OVMA VAX/AXP	QA-MT1AA-UP	48	5
Kit, OVMA VAX/AXP	QA-MT1AA-UP	49	5
Label, "BAXXX Rev" (Rolled) (Not Shown)	36-29163-07	61	7
Label, "Bus ID"	36-33181-01	29	6
Label, "BAXXX Rev" (Rolled) (Not Shown)	36-29163-07	61	13
Label, "Module Number"	36-26883-11	61	12
Label, "Bus ID"	36-33181-01	58	7
Label, Bar Code, Integrated Storage (deleted) (Not Shown)	36-33151-01	64	3
Label, "Switch Marker	36-18940-02	2	3
Label, "Switch Marker	36-18940-02	3	3
Label, "Bar Code" (Not Shown) (deleted)	36-33151-03	2	4
Label, "Bar Code, Integrated Storage" (Not Shown)(deleted)	36-33151-04	15	4
Label, "Bar Code, Integrated Storage" (deleted)(Not Shown)	36-33151-05	31	4
Label, "Bar Code, Integrated Storage" (deleted)(Not Shown)	36-33151-05	32	4
Label, "Bar Code, Integrated Storage"(deleted)(Not Shown)	36-33151-07	46	3
Label, "Bar Code, Integrated Storage"(deleted)(Not Shown)	36-33151-02	14	4
Label, "Bus ID Language Variant"	36-33181-02	46	4
Label, "Bus ID"	36-33181-01	57	7
Label, "Bus ID"	36-33181-01	60	6
Label, "Bus ID"	36-33183-03	27	8
Label, "Bus ID"	36-33183-03	55	7
Label, "Bus ID" (Language Variant)	36-33181-02	23	4
Label, "Bus ID" (Language Variant)	36-33181-02	25	4
Label, "Bus ID, LV"	36-33181-02	44	3
Label, "Bus ID, LV"	36-33181-02	51	3
Label, "Bus ID, LV"	36-33181-02	53	3
Label, "Drive Control"	36-33183-01	27	7

INDEX BY DIGITAL PART DESCRIPTION
400 SERIES MASS STORAGE DEVICES

DESCRIPTION	PART NO.	FIG. NO.	ITEM NO.
Label, "Drive No. 2 Language Variant"	36-33183-02	14	5
Label, "Drive No. 2 Language Variant"	36-33183-02	15	5
Label, "Drive No. 2 Language Variant"	36-33183-02	16	4
Label, "Drive No. 2 Language Variant"	36-33183-02	17	4
Label, "Drive No. 2 Language Variant"	36-33183-02	19	4
Label, "Drive No. 2 Language Variant"	36-33183-02	20	4
Label, "Drive No. 2 Language Variant"	36-33183-02	21	4
Label, "Module Number"	36-26883-45	61	6
Label, "No. 2 Language Variant"	36-33183-04	14	6
Label, "No. 2 Language Variant"	36-33183-04	15	6
Label, "No. 2 Language Variant"	36-33183-04	16	5
Label, "No. 2 Language Variant"	36-33183-04	17	5
Label, "No. 2 Language Variant"	36-33183-04	2	6
Label, "No. 2 Language Variant"	36-33183-04	3	5
Label, "No. 2 Language Variant"	36-33183-04	31	5
Label, "No. 2 Language Variant"	36-33183-04	32	5
Label, "No. 2 Language Variant"	36-33183-04	33	3
Label, "No. 2 Language Variant"	36-33183-04	35	3
Label, "No. 2 Language Variant"	36-33183-04	36	3
Label, "No. 2 Language Variant"	36-33183-04	19	5
Label, "No. 2 Language Variant"	36-33183-04	20	5
Label, "No. 2 Language Variant"	36-33183-04	21	5
Label, "Switch Marker"	36-18940-02	14	3
Label, "Switch Marker"	36-18940-02	15	3
Label, "Switch Marker"	36-18940-02	16	3
Label, "Switch Marker"	36-18940-02	17	3
Label, "Switch Marker"	36-18940-02	23	3
Label, "Switch Marker"	36-18940-02	25	3
Label, "Switch Marker" (deleted)	36-18940-02	31	3
Label, "Switch Marker" (deleted)	36-18940-02	32	3
Label, "Switch Marker"	36-18940-02	19	3
Label, "Switch Marker"	36-18940-02	20	3
Label, "Switch Marker"	36-18940-02	21	3
Label, "Drive No. 2 Language Variant"	36-33183-02	2	5
Label, "Drive No. 2 Language Variant"	36-33183-02	3	4
Mechanics Assembly, RF31	70-24697-01	2	11
Mechanics Assembly, RF31F	70-24697-01	3	10
Mechanics Assembly, RF71	70-23557-01	14	11
Mechanics Assembly, RF72	70-25972-01	15	11
Mechanics Assembly, RF73	70-28814-01	16	11
Mechanics Assembly, TF85	TK85-BX	23	8
Mechanics Assembly, TF86	TK86-BX	25	8
Module, Interface Card	54-19787-02	26	5
Module, Interface Card	54-20136-02	63	5
Module, Interface Card	54-20136-02	65	5
Module, Paddle	54-19787-03	7	3
Module, DSSI Front Panel	54-19791-01	27	9
Module, DSSI Interface Card	54-19787-01	18	6
Module, DSSI Interface Card	54-19787-01	22	4
Module, DSSI Interface Card	54-19787-01	4	5
Module, DSSI Remote Front Panel	54-21530-01	28	2
Module, DSSI Remote Front Panel	54-21530-01	56	2
Module, Device ID Panel	54-20336-01	29	7
Module, Interface Card	54-19787-02	24	5

INDEX BY DIGITAL PART DESCRIPTION
400 SERIES MASS STORAGE DEVICES

DESCRIPTION	PART NO.	FIG. NO.	ITEM NO.
Module, KZQSA	KZQSA-SA	30	3
Module, Paddle	54-19787-03	10	3
Module, Paddle	54-19787-03	13	3
Module, RDAT ID	54-20438-01	57	6
Module, RDAT ID	54-20438-01	58	6
Module, RDAT ID	54-20438-01	60	7
Module, RF31 Drive	54-18329-01	2	9
Module, RF31F Drive	54-18329-02	3	8
Module, RF71 Drive	54-18316-XX	14	9
Module, RF72 Drive	54-10091-XX	15	9
Module, RF73 Drive	54-19119-XX	16	9
Module, RZ56 Drive	29-27889-01	31	8
Module, RZ57 Drive	29-28159-01	32	8
Module, RZ73 Drive	54-19110-XX	35	6
Module, SCSI Device ID Panel	54-20400-01	55	8
Module, SCSI Interface	54-20136-04	52	8
Module, SCSI Interface	54-20136-05	54	8
Module, SCSI Interface	54-23320-01	45	5
Module, SCSI Interface	54-23320-02	40	6
Module, SCSI Interface	54-23320-02	43	6
Module, SCSI Interface	54-23320-03	50	4
Module, SCSI Interface Card	54-20136-01	34	5
Module, SCSI Interface Card	54-20136-01	37	5
Module, SCSI Interface Card	54-20136-03	47	5
Module, TF85	54-19089-01	23	7
Module, TF85/TF86	54-19089-01	25	7
Module, Tape Controller	M7546-00	61	9
Module, Tape Controller	M7559-00	61	3
Module, CD-ROM ID	54-21547-01	59	4
MOUNTING ASSEMBLY, BA400 DUAL SCSI	70-22866-01	50	N/A
MOUNTING ASSEMBLY, BA400 DUAL SCSI	70-22866-02	50	N/A
MOUNTING ASSEMBLY, BA400, DUAL SCSI	70-22866-01	48	1
MOUNTING ASSEMBLY, BA400, DUAL SCSI	70-22866-02	49	1
MOUNTING ASSEMBLY, EF51R/EF52R/EF53 ISE	N/A	22	N/A
MOUNTING ASSEMBLY, RF312 ISE DUAL	70-29475-04	7	N/A
MOUNTING ASSEMBLY, RF31E ISE	70-28086-01	2	1
MOUNTING ASSEMBLY, RF31E ISE	70-28086-01	4	N/A
MOUNTING ASSEMBLY, RF31F ISE	70-28086-02	3	1
MOUNTING ASSEMBLY, RF31F ISE	70-28086-02	4	N/A
MOUNTING ASSEMBLY, RF31T ISE	70-29475-03	5	1
MOUNTING ASSEMBLY, RF31T ISE	70-29475-03	7	N/A
MOUNTING ASSEMBLY, RF35 ISE	70-29475-01	10	N/A
MOUNTING ASSEMBLY, RF35 ISE	70-29475-01	8	1
MOUNTING ASSEMBLY, RF35 ISE DUAL	70-29475-02	10	N/A
MOUNTING ASSEMBLY, RF35 ISE DUAL	70-29475-02	9	1
MOUNTING ASSEMBLY, RF35 ISE DUAL	70-29475-04	6	1
MOUNTING ASSEMBLY, RF36 ISE	70-29475-05	11	1
MOUNTING ASSEMBLY, RF36 ISE (added)	70-29475-05	13	N/A
MOUNTING ASSEMBLY, RF36 ISE DUAL	70-29475-06	12	1
MOUNTING ASSEMBLY, RF36 ISE DUAL (added)	70-29475-06	13	N/A
MOUNTING ASSEMBLY, RF71 ISE	70-28087-01	14	1
MOUNTING ASSEMBLY, RF71 ISE	70-28087-01	18	N/A
MOUNTING ASSEMBLY, RF72 ISE	70-28087-02	15	1
MOUNTING ASSEMBLY, RF72 ISE	70-28087-02	18	N/A

INDEX BY DIGITAL PART DESCRIPTION
400 SERIES MASS STORAGE DEVICES

DESCRIPTION	PART NO.	FIG. NO.	ITEM NO.
MOUNTING ASSEMBLY, RF73 ISE	70-28087-03	16	1
MOUNTING ASSEMBLY, RF73 ISE (added)	70-28087-03	18	N/A
MOUNTING ASSEMBLY, RF74 ISE	70-28087-05	17	1
MOUNTING ASSEMBLY, RF74 ISE (added)	70-28087-05	18	N/A
MOUNTING ASSEMBLY, RRD43 ISE	70-22864-01	44	1
MOUNTING ASSEMBLY, RRD43 ISE	70-22864-01	45	N/A
MOUNTING ASSEMBLY, RZ56 ISE	70-28089-01	31	1
MOUNTING ASSEMBLY, RZ56 ISE	70-28089-01	34	N/A
MOUNTING ASSEMBLY, RZ57 ISE	70-28089-02	32	1
MOUNTING ASSEMBLY, RZ57 ISE	70-28089-02	34	N/A
MOUNTING ASSEMBLY, RZ58 ISE	70-28089-03	33	1
MOUNTING ASSEMBLY, RZ58 ISE (added)	70-28089-03	34	N/A
MOUNTING ASSEMBLY, RZ73 ISE	70-28089-04	35	1
MOUNTING ASSEMBLY, RZ73 ISE	70-28089-04	37	N/A
MOUNTING ASSEMBLY, RZ74 ISE	70-28089-05	36	1
MOUNTING ASSEMBLY, RZ74 ISE	70-28089-05	37	N/A
MOUNTING ASSEMBLY, TF85 ISE	70-28092-01	23	1
MOUNTING ASSEMBLY, TF85 ISE	70-28092-01	24	N/A
MOUNTING ASSEMBLY, TF86 ISE	70-28092-03	25	1
MOUNTING ASSEMBLY, TF86 ISE	70-28092-03	26	N/A
MOUNTING ASSEMBLY, TK50 ISE	70-22839-01	62	1
MOUNTING ASSEMBLY, TK50 ISE	70-22839-01	63	N/A
MOUNTING ASSEMBLY, TK70 ISE	70-28088-01	64	1
MOUNTING ASSEMBLY, TK70 ISE	70-28088-01	65	N/A
MOUNTING ASSEMBLY, TK85 ISE	70-28092-04	51	1
MOUNTING ASSEMBLY, TK85 ISE	70-28092-05	53	1
MOUNTING ASSEMBLY, TLZ04 ISE	70-28090-01	46	1
MOUNTING ASSEMBLY, TLZ04 ISE	70-28090-01	47	N/A
MOUNTING ASSEMBLY, TZ86	70-28092-04	52	N/A
MOUNTING ASSEMBLY, TZ87	70-28092-05	54	N/A
Package Assembly (Bulk Shipment) (Not Shown)	37-01186-07	16	8
Package Assembly (Bulk Shipment) (Not Shown)	37-01186-07	17	7
Package Assembly (Not Shown)	37-01215-01	11	4
Package Assembly (Not Shown)	37-01215-01	12	4
Package Assembly (Not Shown)	37-01215-01	14	8
Package Assembly (Not Shown)	37-01215-01	15	8
Package Assembly (Not Shown)	37-01215-01	16	7
Package Assembly (Not Shown)	37-01215-01	17	7
Package Assembly (Not Shown)	37-01215-01	19	7
Package Assembly (Not Shown)	37-01215-01	20	7
Package Assembly (Not Shown)	37-01215-01	21	7
Package Assembly (Not Shown)	37-01215-01	31	7
Package Assembly (Not Shown)	37-01215-01	32	7
Package Assembly (Not Shown)	37-01215-01	33	5
Package Assembly (Not Shown)	37-01215-01	35	5
Package Assembly (Not Shown)	37-01215-01	36	5
Package Assembly (Not Shown)	37-01215-01	38	4
Package Assembly (Not Shown)	37-01215-01	39	4
Package Assembly (Not Shown)	37-01215-01	41	4
Package Assembly (Not Shown)	37-01215-01	42	4
Package Assembly (Not Shown)	37-01215-01	46	6
Package Assembly (Not Shown)	37-01215-01	5	4
Package Assembly (Not Shown)	37-01215-01	6	4
Package Assembly (Not Shown)	37-01215-01	8	4

INDEX BY DIGITAL PART DESCRIPTION
400 SERIES MASS STORAGE DEVICES

DESCRIPTION	PART NO.	FIG. NO.	ITEM NO.
Package Assembly (Not Shown)	37-01215-01	9	4
Package Assembly (Not Shown)	37-01215-02	62	4
Package Assembly (Not Shown)	37-01215-02	64	5
Package Assembly (Not Shown)	37-01215-04	2	8
Package Assembly (Not Shown)	37-01215-04	3	7
Package Assembly (Not Shown)	37-01215-04	44	6
Package Assembly (Not Shown)	37-01215-05	48	4
Package Assembly (Not Shown)	37-01215-05	49	4
Package Assembly (Not Shown)	37-01215-06	23	6
Package Assembly (Not Shown)	37-01215-06	25	6
Package Assembly (Not Shown)	37-01215-06	51	5
Package Assembly (Not Shown)	37-01215-06	53	5
Panel, Blank Dual	74-33507-01	61	11
Panel, Blank Dual	74-33507-01	61	5
Panel, Blank Filler	74-44062-01	48	8
Plate, Bottom Bracket Adapter	74-44234-01	13	10
Plate, Bottom Bracket Adapter	74-44234-01	40	4
Plate, Bottom Bracket Adapter	74-44234-01	43	4
Plate, Bottom Bracket Adapter	74-44234-01	7	10
Plate, Bottom Bracket Adapter	74-44234-01	10	10
Plate, Skid	74-25652-02	19	8
Plate, Skid	74-25652-02	20	8
Plate, Skid	74-25652-02	21	8
Plate, Top Bracket Adapter	74-44233-01	10	4
Plate, Top Bracket Adapter	74-44233-01	13	4
Plate, Top Bracket Adapter	74-44233-01	40	3
Plate, Top Bracket Adapter	74-44233-01	43	3
Plate, Top Bracket Adapter	74-44233-01	7	4
Screw, Mach Flat Hd No. 6-32 X 5/8	90-06025-02	22	9
Screw, Mach Flat Hd No. 6-32 x 5/8	90-06025-02	52	6
Screw, Mach Flat Hd No. 6-32 x 5/8	90-06025-02	54	6
Screw, Mach M3 Flat Hd	90-40122-04	45	9
Screw, Mach M3 Flat Hd	90-40122-04	50	9
Screw, Mach Pan Hd No. 6-32 x 1/4	90-06020-01	19	9
Screw, Mach Pan Hd No. 6-32 x 1/4	90-06020-01	20	9
Screw, Mach Pan Hd No. 6-32 x 1/4	90-06020-01	21	9
Screw, Mach Pan Hd No. 6-32 x 1/4	90-06020-01	57	8
Screw, Mach Pan Hd No. 6-32 x 5/16	90-06021-01	59	6
Screw, Mach Phi Pan Hd No. 4-40 x 3/8	90-06011-01	35	7
Screw, Mach Truss Hd No. 6-32 x 1/4	90-10971-01	57	4
Screw, Machine Flat Hd No. 6-32 x 5/8	90-06025-02	10	6
Screw, Machine Flat Hd No. 6-32 x 5/8	90-06025-02	13	6
Screw, Machine Flat Hd No. 6-32 x 5/8	90-06025-02	24	7
Screw, Machine Flat Hd No. 6-32 x 5/8	90-06025-02	26	7
Screw, Machine Flat Hd No. 6-32 x 5/8	90-06025-02	40	12
Screw, Machine Flat Hd No. 6-32 x 5/8	90-06025-02	43	12
Screw, Machine Flat Hd No. 6-32 x 5/8	90-06025-02	63	7
Screw, Machine Flat Hd No. 6-32 x 5/8	90-06025-02	65	7
Screw, Machine Flat Hd No. 6-32 x 5/8	90-06025-02	7	6
Screw, Machine Flat Hd No. 6-32 x 5/8 (deleted)	90-06025-02	18	9
Screw, Machine Flat Hd No. 6-32 x 5/8 (deleted)	90-06025-02	4	8
Screw, Machine No. M-3 14 mm	90-11163-01	47	7
Screw, Machine Phi Pan Hd No. 4-40 x 3/8	90-06011-01	14	10
Screw, Machine Phi Pan Hd No. 4-40 x 3/8	90-06011-01	15	10

INDEX BY DIGITAL PART DESCRIPTION
400 SERIES MASS STORAGE DEVICES

DESCRIPTION	PART NO.	FIG. NO.	ITEM NO.
Screw, Machine Phi Pan Hd No. 4-40 x 3/8	90-06011-01	16	10
Screw, Machine Phi Pan Hd No. 4-40 x 3/8	90-06011-01	2	10
Screw, Machine Phi Pan Hd No. 4-40 x 3/8	90-06011-01	3	9
Screw, Machine Phi Pan Hd No. 6-32 x 5/16	90-06021-01	58	5
Screw, Machine Phi Pan Hd No. 6-32 x 1/2 (deleted)	90-06024-02	18	8
Screw, Machine Phi Pan Hd No. 6-32 x 1/2 (deleted)	90-06024-02	4	7
Screw, Phi Pan Hd No. 4-40 x 1/4	90-09315-01	10	12
Screw, Phi Pan Hd No. 4-40 x 1/4	90-09315-01	13	12
Screw, Phi Pan Hd No. 4-40 x 1/4	90-09315-01	18	10
Screw, Phi Pan Hd No. 4-40 x 1/4	90-09315-01	22	10
Screw, Phi Pan Hd No. 4-40 x 1/4	90-09315-01	24	8
Screw, Phi Pan Hd No. 4-40 x 1/4	90-09315-01	26	8
Screw, Phi Pan Hd No. 4-40 x 1/4	90-09315-01	34	8
Screw, Phi Pan Hd No. 4-40 x 1/4	90-09315-01	37	8
Screw, Phi Pan Hd No. 4-40 x 1/4	90-09315-01	4	9
Screw, Phi Pan Hd No. 4-40 x 1/4	90-09315-01	40	11
Screw, Phi Pan Hd No. 4-40 x 1/4	90-09315-01	50	10
Screw, Phi Pan Hd No. 4-40 x 1/4	90-09315-01	52	7
Screw, Phi Pan Hd No. 4-40 x 1/4	90-09315-01	54	7
Screw, Phi Pan Hd No. 4-40 x 1/4	90-09315-01	63	8
Screw, Phi Pan Hd No. 4-40 x 1/4	90-09315-01	65	8
Screw, Phi Pan Hd No. 4-40 x 1/4	90-09315-01	7	12
Screw, Phi Pan Hd No. 4-40 x 1/4	90-09315-01	43	11
Screw, Phi Pan Hd No. 4-40 x 1/4	90-09315-01	45	10
Screw, Phi Pan Hd No. 4-40 x 1/4	90-09315-01	47	8
Screw, Phi Pan Hd No. 6-32 x 5/16	90-06021-01	27	5
Screw, Phi Pan Hd No. 6-32 x 5/16	90-06021-01	29	5
Screw, Phi Pan Hd No. 6-32 x 5/16	90-06021-01	55	5
Screw, Phi Pan Hd No. 6-32 x 5/16	90-06021-01	60	5
Screw, Phi Pan Hd No. 6-32 x 5/16	90-06021-01	66	4
Screw, Sems Phi Hd No. 6-32 x 1/4	90-10174-00	10	8
Screw, Sems Phi Hd No. 6-32 x 1/4	90-10174-00	13	8
Screw, Sems Phi Hd No. 6-32 x 1/4	90-10174-00	40	10
Screw, Sems Phi Hd No. 6-32 x 1/4	90-10174-00	43	10
Screw, Sems Phi Hd No. 6-32 x 1/4	90-10174-00	7	8
Screw, Shoulder Hd No. 6-32 x 1/2 (added)	12-34462-01	18	8
Screw, Shoulder Hd No. 6-32 x 1/2 (added)	12-34462-01	18	9
Screw, Shoulder No. 6-32	12-34462-01	37	7
Screw, Shoulder No. 6-32	12-34462-02	34	7
Screw, Shoulder No. 6-32 x 1/2 (added)	12-34462-01	4	7
Screw, Shoulder No. 6-32 x 1/2 (added)	12-34462-01	4	8
STORAGE ELEMENT, DLTZ07	N/A	49	N/A
STORAGE ELEMENT, EF51R	N/A	19	N/A
STORAGE ELEMENT, EF52R	N/A	20	N/A
STORAGE ELEMENT, EF53	N/A	21	N/A
STORAGE ELEMENT, RF312 DUAL	N/A	6	N/A
STORAGE ELEMENT, RF31E	N/A	2	N/A
STORAGE ELEMENT, RF31F	N/A	3	N/A
Storage Element, RF31T	RF31T-EA	7	9
STORAGE ELEMENT, RF31T	N/A	5	N/A
STORAGE ELEMENT, RF352 DUAL	N/A	9	N/A
STORAGE ELEMENT, RF35E	N/A	8	N/A
Storage Element, RF35E	RF35-EA	10	9
STORAGE ELEMENT, RF362 DUAL	N/A	12	N/A

INDEX BY DIGITAL PART DESCRIPTION
400 SERIES MASS STORAGE DEVICES

DESCRIPTION	PART NO.	FIG. NO.	ITEM NO.
STORAGE ELEMENT, RF36E	N/A	11	N/A
Storage Element, RF36E	RF36-EA	13	9
STORAGE ELEMENT, RF71E	N/A	14	N/A
STORAGE ELEMENT, RF72E	N/A	15	N/A
STORAGE ELEMENT, RF73E	N/A	16	N/A
STORAGE ELEMENT, RF74E	N/A	17	N/A
STORAGE ELEMENT, RRD43	N/A	44	N/A
STORAGE ELEMENT, RZ262 DUAL	N/A	42	N/A
STORAGE ELEMENT, RZ26L	N/A	41	N/A
Storage Element, RZ26L	RZ26L	43	13
STORAGE ELEMENT, RZ282 DUAL	N/A	39	N/A
STORAGE ELEMENT, RZ28E	N/A	38	N/A
Storage Element, RZ28E	RZ28E	40	13
STORAGE ELEMENT, RZ56E	N/A	31	N/A
STORAGE ELEMENT, RZ57E	N/A	32	N/A
STORAGE ELEMENT, RZ58E	N/A	33	N/A
STORAGE ELEMENT, RZ73E	RZ73E	35	N/A
STORAGE ELEMENT, RZ74E	RZ74E	36	N/A
STORAGE ELEMENT, TF85E	N/A	23	N/A
STORAGE ELEMENT, TF86E	N/A	25	N/A
STORAGE ELEMENT, TK50E	N/A	62	N/A
STORAGE ELEMENT, TK70E	N/A	64	N/A
STORAGE ELEMENT, TLZ04	N/A	46	N/A
STORAGE ELEMENT, TLZ07	N/A	48	N/A
STORAGE ELEMENT, TZ86	N/A	51	N/A
STORAGE ELEMENT, TZ87	N/A	53	N/A
Tape Drive Assembly	TF85-BA	24	1
Tape Drive Assembly	TF86-BA	26	1
Tape Drive Assembly	TK50-EA	63	1
Tape Drive Assembly	TK70-EA	65	1
Tape Drive Assembly	TLZ04-AA	47	1
Tape Drive Assembly, Half Height, 5 1/4 Inch, 8 GB, 4MM	TLZ07-BA	50	12
Tape Drive Assembly, SCSI, 20	TZ87-BA	54	10
Tape Drive Assembly, TK86-BX	TZ86-BA	52	10
Tape, Velcro	12-32980-01	27	6
Tape, Velcro	12-32980-01	55	6
TK50E Tape Drive Assembly	TK50E-AA	61	14
TK50E Tape Drive Assembly	TK50E-AF	61	14
TK70E Tape Drive Assembly	TK70E-AA	61	14
TK70E Tape Drive Assembly	TK70E-AF	61	14
TYPICAL DSSI SYSTEM MOUNTING and CABLING	N/A	1	N/A
TYPICAL SCSI SYSTEM MOUNTING and CABLING	N/A	30	N/A
TYPICAL TK SYSTEM MOUNTING and CABLING	N/A	61	N/A
Washer, Retainer	12-30421-01	27	4
Washer, Retainer	12-30421-01	55	4
Washer, Retaining	12-30421-01	29	4
Washer, Retaining	12-30421-01	57	3
Washer, Retaining	12-30421-01	58	4
Washer, Retaining	12-30421-01	59	3
Washer, Retaining	12-30421-01	60	4
Washer, Retaining	12-30421-01	66	3

**INDEX BY DIGITAL PART DESCRIPTION
400 SERIES MASS STORAGE DEVICES**

DESCRIPTION	PART NO.	FIG. NO.	ITEM NO.
--------------------	---------------------	---------------------	---------------------

THIS PAGE INTENTIONALLY LEFT BLANK