

RF Series Integrated Storage Element

User Guide

Order Number: EK-RF72D-UG-008

April 1993

The information in this document is subject to change without notice and should not be construed as a commitment by Digital Equipment Corporation. Digital Equipment Corporation assumes no responsibility for any errors that may appear in this document.

No responsibility is assumed for the use or reliability of software on equipment that is not supplied by Digital Equipment Corporation or its affiliated companies.

Restricted Rights: Use, duplication, or disclosure by the U.S. Government is subject to restrictions as set forth in subparagraph (c)(1)(ii) of the Rights in Technical Data and Computer Software clause at DFARS 252.227-7013.

© Digital Equipment Corporation 1993.

All Rights Reserved.
Printed in U.S.A.

The following are trademarks of Digital Equipment Corporation: BASIC, DEC, DECmailer, DECservice, DSA, MicroVAX, MSCP, Q-bus, SERVICenter, VAX, VAXsimPLUS, VMS, and the DIGITAL logo.

Contents

About This Guide	xiii
1 General Information	
Overview	1-1
In this Chapter	1-1
Introduction	1-1
DSSI Bus	1-2
ISE	1-2
RF31/31F Description	1-3
RF35/RF31T and RF36 Description	1-4
RF72, RF73, and RF74 Description	1-5
Performance Features	1-6
RF31/31F ISE Specifications	1-7
Introduction	1-7
Performance Specifications	1-7
Current and Power Consumption	1-8
Media Specifications	1-8
Environmental Specifications	1-9
RF35/RF31T ISE Specifications	1-10
Introduction	1-10
Performance Specifications	1-10
Current and Power Consumption	1-11
Media Specifications	1-11
Environmental Specifications	1-12
RF36 ISE Specifications	1-14
Introduction	1-14
Performance Specifications	1-14
Current and Power Consumption	1-15
Media Specifications	1-15
Environmental Specifications	1-16
RF72 ISE Specifications	1-18
Introduction	1-18

Performance Specifications	1-18
Current and Power Consumption	1-19
Media Specifications	1-19
Environmental Specifications	1-20
RF73 ISE Specifications	1-21
Introduction	1-21
Performance Specifications	1-21
Current and Power Consumption	1-22
Media Specifications	1-22
Environmental Specifications	1-23
RF74 ISE Specifications	1-24
Introduction	1-24
Performance Specifications	1-24
Current and Power Consumption	1-25
Media Specifications	1-25
Environmental Specifications	1-26

2 Theory of Operation

Physical Description	2-1
In this Chapter	2-1
Overview	2-1
FRUs	2-2
HDA	2-3
RF3x/RF7x Comparison	2-4
Drive Module	2-5
Interfaces	2-5
Interface Functions	2-7
Functional Description	2-9
Drive Module Electronics	2-9
Divided Area Functions	2-11
Drive Module Block Diagram	2-12
Data Flow	2-13
Data Protection	2-14
Command Flow	2-15
Command Protection	2-16
Firmware	2-17
Introduction	2-17
Firmware Structure	2-18
Initialization	2-18
STATUS THREADS Command	2-18
Thread Interfaces	2-19
Communication Services	2-19

MSCP Server	2-19
Multihost Server	2-20
Seek Ordering	2-21
Request Fragmentation	2-21
Example Fragmentation	2-21
Read Cache	2-22
RCT Caching	2-22
Sector Format and Error Handling	2-23
Introduction	2-23
Disk Sector Format	2-23
Sector Header Process	2-24
R/W Portion of Block	2-25
Flags Field	2-25
LTN0 Field	2-25
EDC Field	2-25
ECC Field	2-25
Head and Track Scatter Compensation	2-26
LTN0 Track Reference Point	2-27
Diagnostics and Utilities	2-28
Introduction	2-28
POST	2-28
POST Coverage	2-28
POST Verifications	2-29
After POST	2-29
DUP Server	2-29
Diagnostic and Utility Programs	2-31
Program Descriptions	2-32
Detecting Errors	2-33
Detecting Errors Using PARAMS	2-34
Error Codes	2-34
Fatal Error	2-34
Transient Errors	2-35
Error History	2-35
Detecting Soft Errors	2-36
Introduction	2-36
MSCP Error Logs	2-36
Error Log Summary	2-36
Soft Errors not Reported	2-37

3 Controls and Indicators

Introduction	3-1
In this Chapter	3-1
OCP	3-1
BA200 Series Controls and Indicators	3-2
OCP	3-2
OCP Controls	3-3
OCP Indicators	3-4
BA400 Series Controls and Indicators	3-5
OCP	3-5
Control and Indicator Functions	3-6
RF35/RF31T and RF36 Write-Protection	3-7
SF7x Enclosure Controls and Indicators	3-13
OCP	3-13
Control and Indicator Functions	3-14
Changing the DSSI Node ID Plugs (BA200 and BA400 Series OCPs)	3-15
Spare Plugs	3-15
Removal	3-15
Insertion	3-15
Renumbering ISEs	3-15
ISE Controls and Indicators	3-16
Description	3-16
Assigning DSSI Node ID	3-19
Drive Module LEDs	3-20

4 Local Programs

Accessing Local Programs	4-1
In this Chapter	4-1
Overview	4-1
Using VMS	4-3
Using Console Commands	4-4
Q-bus Adapters	4-4
Embedded Adapters	4-5
Using MDM	4-6
Local Programs	4-7
Overview	4-7
DIRECT	4-7
Description	4-7
Example	4-7
DRVEXR	4-8

Description	4-8
Stopping DRVEXR	4-8
Dialogue	4-9
DRVEXR Modes	4-10
Mode/Dialogue Relationship	4-10
Example	4-10
DRVSTST	4-11
Description	4-11
Dialogue	4-11
Error Messages	4-12
DRVSTST Examples	4-13
HISTORY	4-14
Description	4-14
Example	4-14
ERASE	4-15
Description	4-15
LBN and RBN	4-15
ERASE Process	4-16
Accessing ERASE	4-17
Stopping ERASE	4-17
Dialogue	4-17
Example	4-18
VERIFY	4-19
Description	4-19
Accessing VERIFY	4-19
Dialogue	4-19
Example	4-20
Error Messages	4-23
Warning Messages	4-24
DKUTIL	4-25
Description	4-25
Accessing DKUTIL	4-25
DKUTIL Process	4-25
Stopping DKUTIL	4-25
DKUTIL Commands	4-26
DKUTIL Command Modifiers	4-27
DEFAULT	4-29
DEFAULT Syntax	4-29
DEFAULT Example	4-29
DISPLAY	4-30
DISPLAY Syntax	4-30
DISPLAY Modifiers	4-30
DISPLAY Example	4-31

DUMP	4-32
DUMP Syntax	4-32
DUMP Modifiers	4-33
DUMP Example	4-34
EXIT	4-35
EXIT Syntax	4-35
EXIT Example	4-35
GET	4-36
GET Syntax	4-36
GET Modifiers	4-36
GET Example	4-36
HELP	4-37
HELP Syntax	4-37
HELP Example	4-37
POP	4-38
POP Syntax	4-38
POP Example	4-38
PUSH	4-39
PUSH Syntax	4-39
PUSH Example	4-39
REPLACE	4-40
REPLACE Syntax	4-40
REPLACE Example	4-40
SET SIZE	4-41
SET SIZE Syntax	4-41
SET SIZE Example	4-41
PARAMS	4-42
Description	4-42
Accessing PARAMS	4-42
PARAMS Process	4-42
Stopping PARAMS	4-42
PARAMS Commands	4-43
EXIT	4-44
EXIT Syntax	4-44
EXIT Example	4-44
HELP	4-45
HELP Syntax	4-45
HELP Example	4-45
LOCATE	4-46
LOCATE Syntax	4-46
LOCATE Example	4-46
SET	4-47
SET Syntax	4-47

SET Example	4-47
SET and SHOW Parameters	4-48
SHOW	4-49
SHOW Syntax	4-49
SHOW Classes	4-50
SHOW Example	4-51
STATUS	4-52
STATUS Syntax	4-52
STATUS Types	4-52
STATUS Examples	4-53
WRITE	4-54
Reasons for Failure	4-54
WRITE Syntax	4-55
WRITE Example	4-55
ZERO	4-56
ZERO Syntax	4-56
Counter Types	4-56
ZERO Example	4-57

5 Troubleshooting Procedures

Performing Troubleshooting Procedures	5-1
In this Chapter	5-1
Introduction	5-1
Self-Tests	5-2
Failure Indications	5-3
Before Calling Digital Customer Services	5-4

6 Digital Customer Services

Types of Service Plans	6-1
In this Chapter	6-1
On-Site Service	6-1
BASIC Service	6-1
DECservice	6-2
Carry-In service	6-2
DECmailer	6-2
Per Call Service	6-3
For More Information	6-3

Index

Examples

3-1	Setting Hardware Write-Protection Through Firmware	3-11
3-2	Setting Hardware Write-Protection Through VMS	3-12

Figures

1-1	RF31 ISE	1-3
1-2	RF35/RF31T and RF36 ISE	1-4
1-3	RF72, RF73, and RF74 ISE	1-5
1-4	RF35/RF31T ISE Side and Bottom Views	1-13
1-5	RF36 ISE Side and Bottom Views	1-17
2-1	RF31/31F and RF72/73/74 ISE Basic Components	2-2
2-2	RF31/RF31F Drive Module Interfaces	2-5
2-3	RF35/RF31T Drive Module Interfaces	2-6
2-4	RF31 Drive Module Electronics	2-9
2-5	RF35/RF31T Drive Module Electronics	2-10
2-6	Drive Module Block Diagram	2-12
2-7	Data Flow Through the Drive Module	2-13
2-8	Command Flow Through the Drive Module	2-15
2-9	Firmware Structure	2-17
2-10	Multihost Server	2-20
2-11	Request Fragmentation	2-21
2-12	RCT is Cached in Controller RAM	2-22
2-13	RF31 Sector Format	2-23
2-14	Head and Track Scatter Compensation	2-26
2-15	On-Disk Format Anchored at LTN0 on Each Surface (RF31/31F)	2-27
2-16	POST Coverage (RF31 shown)	2-28
2-17	Multihost DUP Server	2-30
2-18	Diagnostics and Utilities	2-31
2-19	Location of the Fault LEDs (RF31 Shown)	2-33
3-1	BA200 Series DSSI Operator Control Panel	3-2
3-2	BA400 Series OCP for DSSI ISEs	3-5
3-3	SF7x Controls and Indicators	3-13

3-4	RF31/31F, RF72, RF73, and RF74 Drive Module Switch and LED Locations	3-17
3-5	RF35/31T and RF36 Drive Module Options Connector and LED Locations	3-18

Tables

2-1	RF31/RF31F Interfaces	2-7
2-2	RF35/RF31T Interfaces	2-8
3-1	RF31/31F, RF72, RF73, and RF74 DSSI IDs	3-19
3-2	RF35/31T and RF36 DSSI IDs	3-19

About This Guide

- Introduction** This user guide is intended for users of the RF Series Integrated Storage Elements (ISEs).
- Structure** This user guide includes the following six chapters with information on the RF31/31F, RF35/31T, RF36, RF72, RF73, and RF74 ISEs.
- Chapter 1, General Information, describes the RF series ISEs, and the DSSI bus function and performance features. It also lists specifications.
 - Chapter 2, Theory of Operation, covers ISE physical descriptions, head-disk assemblies (HDAs), functional descriptions, firmware, and diagnostics and utilities.
 - Chapter 3, Controls and Indicators, describes the operator control panel (OCP) on the system enclosure and the ISE drive module.
 - Chapter 4, Local Programs, describes the local programs and how they can be accessed through VMS, from the console, and through MDM.
 - Chapter 5, Troubleshooting Procedures, describes what to do if an ISE operates incorrectly. It also describes failure indications and internal self-tests.
 - Chapter 6, Digital Customer Services, describes a range of flexible services offered by Digital Services.

1

General Information

Overview

In this Chapter

This chapter covers the following topics:

- Definition of RF31/31F, RF35/31T, RF36, RF72, RF73, and RF74 Integrated Storage Elements (ISEs)
- DSSI bus function
- Performance features
- Specifications

Introduction

The RF31/31F, RF35/31T, RF36, RF72, RF73, and RF74 ISEs are disk storage devices based on the Digital Storage Architecture (DSA) using the DSSI bus and interface. The RF31/31F is a half-height, 5¼-inch disk storage device. The RF35/31T and the RF36 are both 3½-inch disk storage devices. The RF72, RF73, and RF74 are full-height, 5¼-inch disk storage devices.

The RF31F is a high-speed, lower-capacity version of the RF31 ISE. Unless otherwise specified, references to the RF31 ISE in this manual apply to the RF31F ISE also.

The RF31T is a high-speed, lower-capacity version of the RF35 ISE. Unless otherwise specified, references to the RF35 ISE in this manual apply to the RF31T ISE also.

DSSI Bus

The DSSI bus is a logical equivalent to the CI bus used on larger Digital systems. The DSSI bus allows one or more hosts to communicate directly with storage devices, using the Systems Communications Architecture (SCA) protocols. As many as eight nodes (ISEs and adapters) can be connected to one DSSI bus.

The DSSI bus is a 50-conductor cable. Inside an enclosure, the bus may be a flat ribbon cable or a round bundle of twisted pairs. Between enclosures, the bus is a shielded round cable approximately 1/2-inch in diameter.

ISE

An ISE is a DSSI device that contains an embedded intelligent controller and an on-board MSCP server. Each ISE executes commands and transfers data independently of other ISEs attached to the DSSI bus. Commands and data are transferred over the DSSI bus in small packets, so multiple ISE transfers are efficiently multiplexed.

**RF31/31F
Description**

The RF31 ISE (Figure 1-1) is a half-height, 5¼-inch fixed disk storage device. Its dimensions are 20.9 cm (8.21 in) by 14.7 cm (5.79 in) by 4.1 cm (1.62 in).

Figure 1-1 RF31 ISE

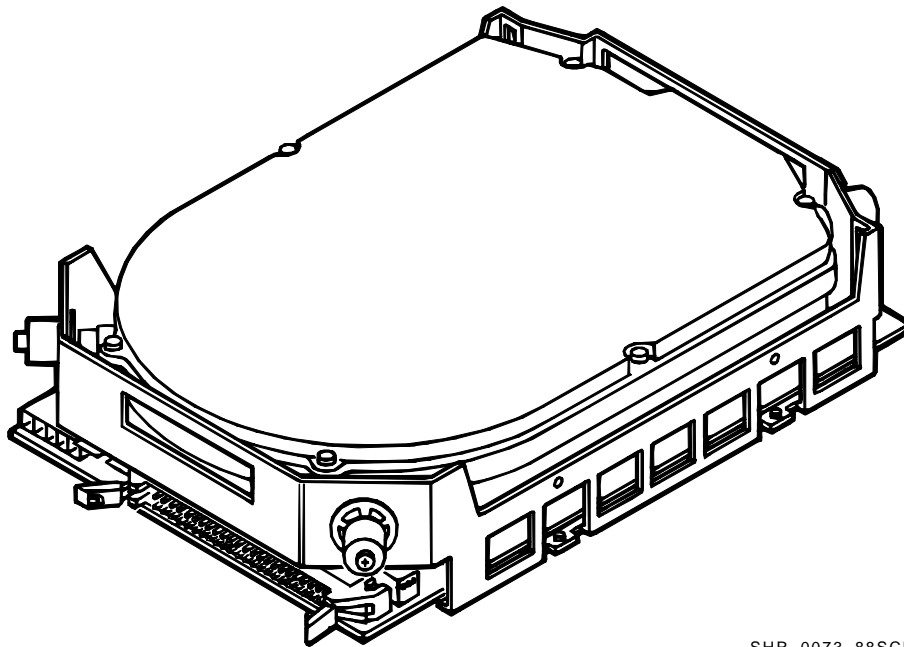

SHR_0073_88SCN
SHR_X1075_89_SCN

**RF35/RF31T
and RF36
Description**

The RF35/RF31T and RF36 ISE, shown in Figure 1-2, is a 3½-inch fixed disk storage device. Its dimensions are 14.60 cm (5.75 in) by 10.16 cm (4.0 in) by 4.1 cm (1.62 in).

Figure 1-2 RF35/RF31T and RF36 ISE

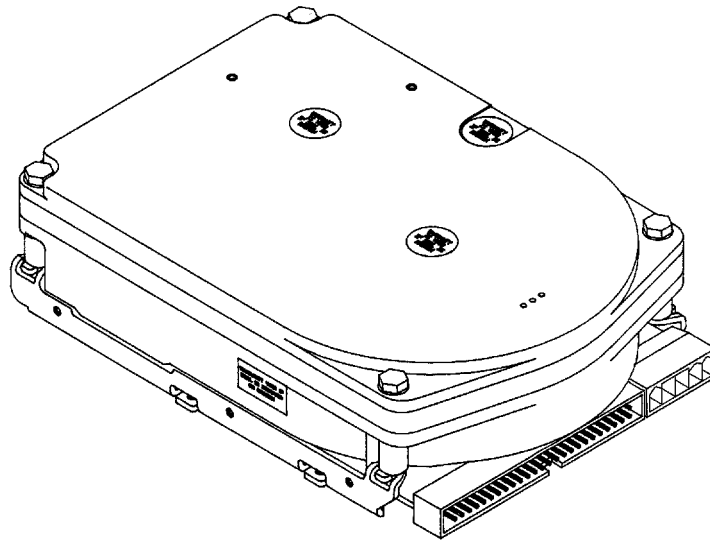

**RF72, RF73,
and RF74
Description**

The RF72, RF73, and RF74 ISE, shown in Figure 1-3, is a full-height, 5¼-inch fixed disk storage device. Its dimensions are 20.9 cm (8.21 in) by 14.7 cm (5.79 in) by 8.3 cm (3.25 in).

Figure 1-3 RF72, RF73, and RF74 ISE

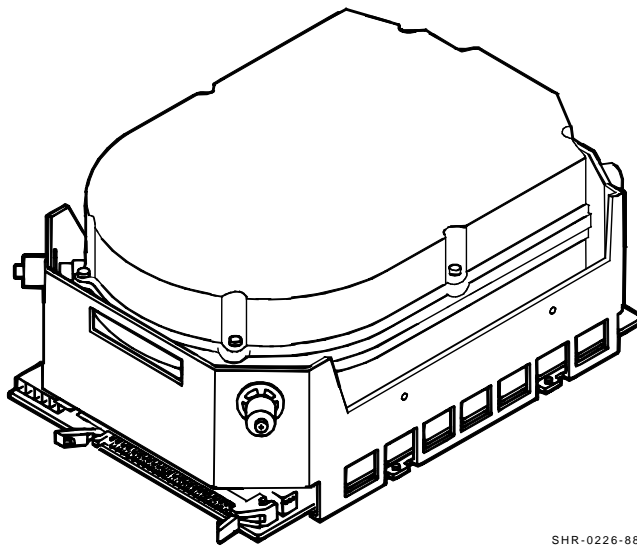

SHR-0226-88
SHR_X1074_89_SCN

Performance Features

The RF31, RF31T, RF35, RF36, RF72, RF73, and RF74 ISEs offer powerful performance features not typically available on disk storage devices in this form factor. The following table lists some of the features, many of which are described in more detail in Chapter 2.

Feature	Function
Multihost support	This allows a single ISE to be used by two hosts at the same time. For example, two MicroVAX 3800 systems can be booted from a single ISE.
Seek ordering	When more than one I/O command is outstanding, the ISE performs the commands in an order that minimizes seek time. The commands considered for seek ordering include the commands from all hosts.
Request fragmentation	This technique breaks single I/O requests into smaller pieces that may be optimized independently. The result is lower rotational latency and, consequently, faster access time for large requests.
Quadruplicated headers	The headers preceding each data block are replicated four times to make sure data is not lost because of header errors.
264-bit ECC	DSSI ISEs store a large, 264-bit error correction code (ECC) in each block, capable of correcting up to 120 erroneous bits.
Controller-initiated BBR	With controller-initiated bad block replacement (BBR), the ISE presents the host with a set of logically contiguous blocks, and disk capacity never shrinks because bad blocks are detected and automatically moved to spare blocks.
RCT Cache	DSSI ISEs cache the replacement control table (RCT), allowing replaced blocks to be located without the time required for seeks to and from the RCT stored on the media.
Read-ahead Cache	The ISEs incorporate a multitrack read cache to reduce latency.

RF31/31F ISE Specifications

Introduction This section lists performance, power, media, and environmental specifications for the RF31 and RF31F ISEs.

Performance Specifications The following table summarizes the performance specifications of the RF31 and RF31F ISEs.

Specification	RF31	RF31F
Formatted storage capacity	381 Mbytes	200 Mbytes
Average seek time	15.3 ms	12.2 ms
Average access time	23.6 ms	20.5 ms
Peak transfer rate to DSSI bus	4.0 Mbytes/second	
Total start time	<60 seconds	
Time to attain full r/min	<15 seconds	
Internal diagnostics	<33 seconds	
Spin-down	<15 seconds	

Current and Power Consumption

The following table summarizes the maximum current and typical power consumption specifications for the RF31 and RF31F ISEs.

Specification	Value
5 V supply current	1.2 A max.
12 V supply current	3.0 A (peak, first 3 seconds (nominal) of spin-up)
	0.7 A max. (idle)
	1.3 A max. (continuous random seeks)
Total power	12.6 W typical (idle)
	18.7 W typical (continuous random seeks)

Media Specifications

The following table summarizes the specifications for the RF31 and RF31F storage media.

Specification	RF31	RF31F
Data tracks per surface	1,861	984
Sectors per track	50 data sectors 1 replacement sector	50 data sectors 1 replacement sector
Data surfaces per drive	8	8
Tracks per inch	1,875	1,875
Bits per inch	30,064	30,064
Areal density	57.35 Mbits/in ²	57.35 Mbits/in ²
Disk type	Thin film	Thin film
Servo	Fully embedded	Fully embedded
Positioner	Rotary	Rotary
R/W code	RLL 1,7	RLL 1,7

Environmental Specifications

The following table summarizes the environmental specifications for the RF31 and RF31F ISEs.

Specification	Value
Temperature	
Operating	10 to 50°C (50 to 122°F), ambient, with a gradient of 11°C (20°F) per hour (as introduced to the drive enclosure)
Non-operating	-40 to 66°C (-40 to 151°F), ambient, with a gradient of 20°C (36°F) per hour
Relative humidity	
Operating	10 to 90% with maximum wet bulb temperature of 28°C (82°F) and a minimum dew point of 2°C (36°F), with no condensation
Non-operating (storage/shipping)	8 to 95%, with no condensation
Altitude	
Operating	2,438 meters (8,000 feet)
Non-operating	4,876 meters (16,000 feet)
Noise (closed office environment)	<5.1 Bels, idle <5.6 Bels, seeking
Airflow	10 ft ³ /min (minimum)
Agency compliance	UL, CSA, IEC 380, IEC 435, VDE 804

RF35/RF31T ISE Specifications

Introduction This section lists performance, power, media, and environmental specifications for the RF35/RF31T ISE.

Performance Specifications The following table summarizes the performance specifications of the RF35/RF31T ISE.

Specification	RF35	RF31T
Formatted storage capacity	852 Mbytes	381 Mbytes
Average seek time	9.5 ms	7.5 ms
Average access time	15.1 ms	13.1 ms
Peak transfer rate to DSSI bus	4.0 Mbytes/s	4.0 Mbytes/s
Total start time	<30 s	<30 s
Time to attain full r/min	<15 s	<15 s
Internal diagnostics	<15 s	<15 s
Spin-down	<15 s	<15 s

Current and Power Consumption

The following table summarizes the maximum current and typical power consumption specifications for the RF35/RF31T ISE.

Specification	Value
5 V supply current	0.85 A max.
12 V supply current	2.29 A (peak, first 3 seconds (nominal) of spin-up)
	0.74 A max. (idle)
	1.56 A max. peak (continuous random seeks)
	0.96 A max. avg. (continuous random seeks)
Total power	11.3 W typical (idle) 13.8 W typical (continuous random seeks)

Media Specifications

The following table summarizes the specifications for the RF35/RF31T storage media.

Specification	RF35	RF31T
Data tracks per surface	2,086	933
Sectors per track	57 data sectors 1 replacement sector	57 data sectors 1 replacement sector
Data surfaces per drive	14	14
Tracks per inch	2,650	2,650
Bits per inch	48,300	48,300
Areal density	128 Mbits/in ²	128 Mbits/in ²
Disk type	Thin film	Thin film
Servo	Fully embedded	Fully embedded
Positioner	Rotary	Rotary
R/W code	RLL 1,7	RLL 1,7

Environmental Specifications

The following table summarizes the environmental specifications for the RF35/RF31T ISE.

Specification	Value
Temperature	
Operating	10 to 50°C (50 to 122°F), ambient, with a gradient of 11°C (20°F) per hour (as introduced to the drive enclosure)
Non-operating	-40 to 66°C (-40 to 151°F), ambient, with a gradient of 20°C (36°F) per hour
Relative humidity	
Operating	10 to 90% with maximum wet bulb temperature of 28°C (82°F) and a minimum dew point of 2°C (36°F), with no condensation
Non-operating (storage/shipping)	8 to 95%, with no condensation
Altitude	
Operating	2,438 meters (8,000 feet)
Non-operating	4,876 meters (16,000 feet)
Noise (closed office environment)	<5.4 Bels, idle <5.0 Bels, seeking
Airflow (Figure 1-4)	Airflow to the drive should be sufficient to component case temperatures below the following maximums:
HDA	60°C
E2 CPU	85°C
E5 ADASP	80°C
E13 QTPD	90°C
E14 Apache	80°C
Agency compliance	UL, CSA, IEC 950, TUV

Figure 1-4 shows the side and bottom views of the RF35/RF31T ISE.

Figure 1-4 RF35/RF31T ISE Side and Bottom Views

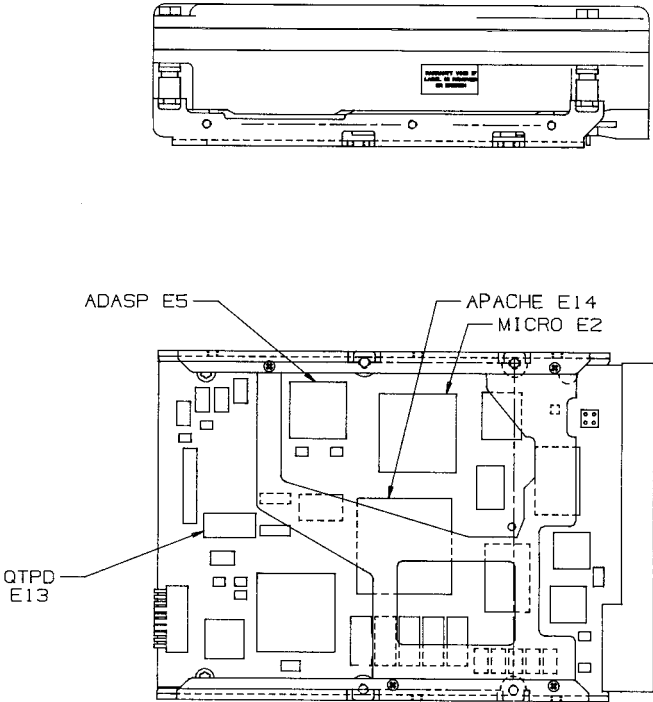

RF36 ISE Specifications

Introduction This section lists performance, power, media, and environmental specifications for the RF36 ISE.

Performance Specifications The following table summarizes the performance specifications of the RF36 ISE.

Specification	RF36
Formatted storage capacity	1600 Mbytes
Average seek time	9.7 ms
Average access time	15.6 ms
Peak transfer rate to DSSI bus	5.0 Mbytes/s
Total start time	<30 s
Time to attain full r/min	<15 s
Internal diagnostics	<15 s
Spin-down	<15 s

Current and Power Consumption

The following table summarizes the maximum current and typical power consumption specifications for the RF36 ISE.

Specification	Value
5 V supply current	0.86 A max.
12 V supply current	2.89 A (peak, first 3 seconds (nominal) of spin-up)
	0.69 A max. (idle)
	1.70 A max peak (continuous random seeks)
	0.96 A max avg. (continuous random seeks)
Total power	11.46 W typical (idle)
	14.9 W typical (continuous random seeks)

Media Specifications

The following table summarizes the specifications for the RF36 storage media.

Specification	RF36
Data tracks per surface	2,086
Sectors per track	Band 0—53 data sectors 1 replacement sector
	Band 1—71 data sectors 1 replacement sector
	Band 2—80 data sectors 1 replacement sector
	Band 3—107 data sectors 1 replacement sector
Data surfaces per drive	16
Tracks per inch	2,756
Bits per inch	52,500
Areal density	144 Mbits/in ²
Disk type	Thin film
Servo	Fully embedded
Positioner	Rotary
R/W code	RLL 1,7

Environmental Specifications

The following table summarizes the environmental specifications for the RF36 ISE.

Specification	Value
Temperature	
Operating	10 to 50°C (50 to 122°F), ambient, with a gradient of 11°C (20°F) per hour (as introduced to the drive enclosure)
Non-operating	-40 to 66°C (-40 to 151°F), ambient, with a gradient of 20°C (36°F) per hour
Relative humidity	
Operating	10 to 90% with maximum wet bulb temperature of 28°C (82°F) and a minimum dew point of 2°C (36°F), with no condensation
Non-operating (storage/shipping)	8 to 95%, with no condensation
Altitude	
Operating	2,438 meters (8,000 feet)
Non-operating	4,876 meters (16,000 feet)
Noise (closed office environment)	<4.4 Bels, idle <5.0 Bels, seeking
Airflow (Figure 1-5)	Airflow to the drive should be sufficient to component case temperatures below the following maximums:
HDA	60°C
E2 CPU	85°C
E5 ADASP	80°C
E13 QTPD	90°C
E14 Apache	80°C
Agency compliance	UL, CSA, IEC 950, TUV

Figure 1-5 shows the side and bottom views of the RF36 ISE.

Figure 1-5 RF36 ISE Side and Bottom Views

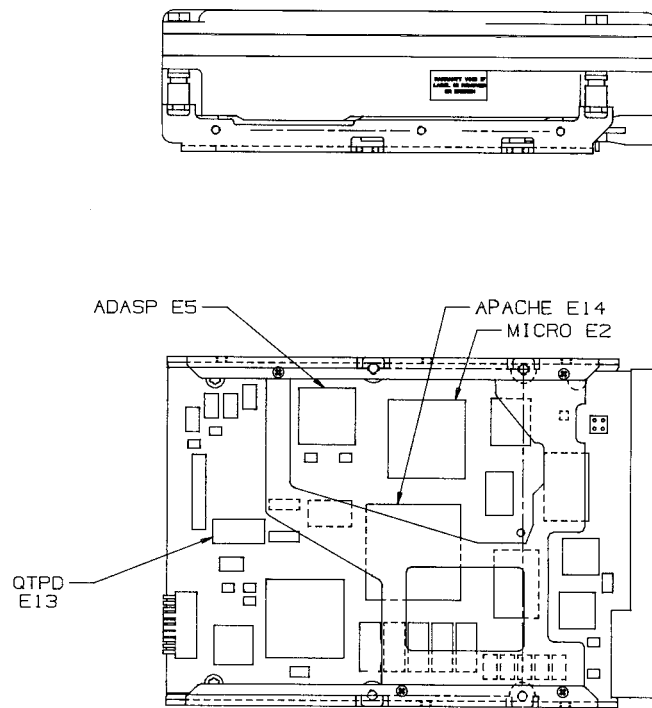

RF72 ISE Specifications

Introduction This section lists performance, power, media, and environmental specifications for the RF72 ISE.

Performance Specifications The following table summarizes the performance specifications of the RF72 ISE.

Specification	Value
Data storage capacity	1 Gbyte, formatted
Average seek time	13.3 ms
Average access time	21.6 ms
Peak transfer rate to DSSI bus	4.0 Mbytes/second
Start time	<60 seconds, total
Time to attain full r/min	<15 seconds
Internal diagnostics	<33 seconds
Spin-down	<15 seconds

Current and Power Consumption

The following table summarizes the maximum current and typical power consumption specifications for the RF72 ISE.

Specification	Value
5 V supply current	1.5 A
12 V supply current	5.4 A (peak, first 3 seconds (nominal) of spin-up)
	1.1 A (idle)
	2.3 A (continuous random seeks)
Total power	20.7 W (idle)
	34.5 W (continuous random seeks)

Media Specifications

The following table summarizes the storage media specifications for the RF72 ISE.

Specification	Value
Data tracks per surface	1,861
Sectors per track	50 data sectors 1 replacement sector
Data surfaces per drive	21
Tracks per inch	1,875
Bits per inch	30,064
Areal density	57.35 Mbits/in ²
Disk type	Thin film
Servo	Fully embedded
Positioner	Rotary
R/W code	RLL 1,7

Environmental Specifications

The following table summarizes the environmental specifications for the RF72 ISE.

Specification	Value
Temperature	
Operating	10 to 50°C (50 to 122°F), ambient, with a gradient of 11°C (20°F) per hour (as introduced to the drive enclosure)
Non-operating	-40 to 66°C (-40 to 151°F), ambient, with a gradient of 20°C (36°F) per hour
Relative humidity	
Operating	10 to 90% with maximum wet bulb temperature of 28°C (82°F) and a minimum dew point of 2°C (36°F), with no condensation
Non-operating (storage/shipping)	8 to 95%, with no condensation
Altitude	
Operating	2,438 meters (8,000 feet)
Non-operating	4,876 meters (16,000 feet)
Noise (closed office environment)	<5.1 Bels, idle <5.8 Bels, seeking
Airflow	15 ft ³ /min (minimum)

RF73 ISE Specifications

Introduction This section lists performance, power, media, and environmental specifications for the RF73 ISE.

Performance Specifications The following table summarizes the performance specifications of the RF73 ISE.

Specification	Value
Data storage capacity	2 Gbytes, formatted
Average seek time	12.9 ms
Average access time	21.2 ms
Peak transfer rate to DSSI bus	4.0 Mbytes/second
Start time	<60 seconds, total
Time to attain full r/min	<15 seconds
Internal diagnostics	<33 seconds
Spin-down	<15 seconds

Current and Power Consumption

The following table summarizes the maximum current and typical power consumption specifications for the RF73 ISE.

Specification	Value
5 V supply current	1.20 A
12 V supply current	5.00 A (peak, first 3 seconds (nominal) of spin-up)
	1.20 A (idle)
	4.00 A max peak (continuous random seeks)
	1.75 A max avg. (continuous random seeks)
Total power	17.0 W (idle)
	22.9 W (continuous random seeks)

Media Specifications

The following table summarizes the storage media specifications for the RF73 ISE.

Specification	Value
Data tracks per surface	2,620
Sectors per track	71 data sectors 1 replacement sector
Data surfaces per drive	21
Tracks per inch	2,432
Bits per inch	43,880
Areal density	106.72 Mbits/in ²
Disk type	Thin film
Servo	Fully embedded
Positioner	Rotary
R/W code	RLL 1,7

Environmental Specifications

The following table summarizes the environmental specifications for the RF73 ISE.

Specification	Value
Temperature	
Operating	10 to 50°C (50 to 122°F), ambient, with a gradient of 11°C (20°F) per hour (as introduced to the drive enclosure)
Non-operating	-40 to 66°C (-40 to 151°F), ambient, with a gradient of 20°C (36°F) per hour
Relative humidity	
Operating	10 to 90% with maximum wet bulb temperature of 28°C (82°F) and a minimum dew point of 2°C (36°F), with no condensation
Non-operating (storage/shipping)	8 to 95%, with no condensation
Altitude	
Operating	2,438 meters (8,000 feet)
Non-operating	4,876 meters (16,000 feet)
Noise (closed office environment)	<4.6 to 4.9 Bels, idle <5.7 Bels, seeking
Airflow	10 ft ³ /min (minimum)

RF74 ISE Specifications

Introduction This section lists performance, power, media, and environmental specifications for the RF74 ISE.

Performance Specifications The following table summarizes the performance specifications of the RF74 ISE.

Specification	Value
Data storage capacity	3.5 Gbytes, formatted
Average seek time	12.5 ms
Average access time	18.1 ms
Peak transfer rate to DSSI bus	5.0 Mbytes/second
Start time	<30 seconds, total
Time to attain full r/min	<20 seconds
Internal diagnostics	<15 seconds
Spin-down	<20 seconds

Current and Power Consumption

The following table summarizes the maximum current and typical power consumption specifications for the RF74 ISE.

Specification	Value
5 V supply current	1.20 A
12 V supply current	5.60 A (peak, first 3 seconds (nominal) of spin-up) 2.40 A (idle) 4.00 A max peak (continuous random seeks) 2.90 A max avg. (continuous random seeks)
Total power	34.8 W (idle) 40.8 W (continuous random seeks)

Media Specifications

The following table summarizes the storage media specifications for the RF74 ISE.

Specification	Value
Data tracks per surface	3,058
Sectors per track	Band 0—Not used Band 1—79 data sectors 1 replacement sector Band 2—89 data sectors 1 replacement sector Band 3—119 data sectors 1 replacement sector
Data surfaces per drive	25
Tracks per inch	2,756
Bits per inch	44,700
Areal density	123 Mbits/in ²
Disk type	Thin film
Servo	Fully embedded
Positioner	Rotary
R/W code	RLL 1,7

Environmental Specifications

The following table summarizes the environmental specifications for the RF74 ISE.

Specification	Value
Temperature	
Operating	10 to 50°C (50 to 122°F), ambient, with a gradient of 11°C (20°F) per hour (as introduced to the drive enclosure)
Non-operating	-40 to 66°C (-40 to 151°F), ambient, with a gradient of 20°C (36°F) per hour
Relative humidity	
Operating	10 to 90% with maximum wet bulb temperature of 28°C (82°F) and a minimum dew point of 2°C (36°F), with no condensation
Non-operating (storage/shipping)	8 to 95%, with no condensation
Altitude	
Operating	2,438 meters (8,000 feet)
Non-operating	4,876 meters (16,000 feet)
Noise (closed office environment)	<5.2 Bels, idle <5.7 Bels, seeking
Airflow	10 ft ³ /min (minimum)

2

Theory of Operation

Physical Description

In this Chapter

This chapter covers the following topics on RF31/31F, RF35/31T, RF36, RF72, RF73, and RF74 ISEs:

- Physical descriptions
- Head-disk assemblies (HDAs)
- Functional descriptions
- Firmware
- Diagnostics and utilities

Overview

The ISE consists of two basic components:

- An HDA that contains the disks and drive mechanisms
- A printed circuit board called the drive module, which contains the disk controller and drive electronics

The RF31 and RF31F ISEs use similar drive modules. The RF35 and RF31T ISEs use similar drive modules. The RF36 uses a unique drive module. The RF72, RF73, and RF74 ISEs use similar drive modules. The HDA is different for each ISE:

- RF31/RF31F ISE has 4 disks
- RF35/RF31T ISE has 7 disks
- RF36 ISE has 8 disks
- RF72 and RF73 ISEs each have 11 disks
- RF74 ISE has 13 disks

FRUs

Figure 2-1 shows the RF31/31F, RF72, RF73 and RF74 ISEs with the field replaceable units (FRUs). The mechanics set consists of the HDA, drive chassis, and shock mount assembly. Note that the ISE for both the RF35/31T and the RF36 is a single FRU.

Figure 2-1 RF31/31F and RF72/73/74 ISE Basic Components

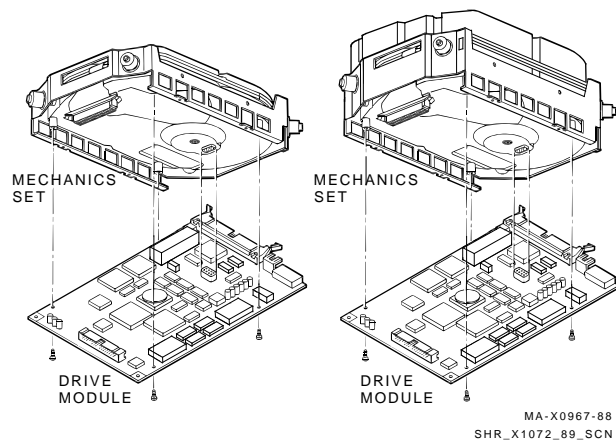

HDA

The HDA contains the:

- Disks
- Heads
- Spindle motor
- Rotary positioner

The RF31/31F HDA has four disks and eight heads. The RF35/31T HDA has seven disks and fourteen heads. The RF36 HDA has eight disks and sixteen heads. The RF72 and RF73 HDAs each have eleven disks and twenty-two heads. The RF74 HDA has thirteen disks and twenty-six heads. Each ISE uses an embedded digital servo for track following, so there is no dedicated servo surface. All surfaces are used for user data storage.

**RF3x/RF7x
Comparison**

The following table compares the amount of data storage among the RF Series ISEs.

ISE	Usable data surfaces (tracks)	Data tracks/surface (cylinders/spindle)	Sectors per track
RF31	8	1,861	51 (50 data, 1 replacement)
RF31F	8	984	51 (50 data, 1 replacement)
RF35	14	2,086	58 (57 data, 1 replacement)
RF31T	14	933	58 (57 data, 1 replacement)
RF36	16	2,599	Band 0 - 54 (53 data, 1 replacement) Band 1 - 72 (71 data, 1 replacement) Band 2 - 81 (80 data, 1 replacement) Band 3 - 108 (107 data, 1 replacement)
RF72 ¹	21	1,861	51 (50 data, 1 replacement)
RF72 ¹	21	1,861	51 (50 data, 1 replacement)
RF73 ¹	21	2,620	72 (71 data, 1 replacement)
RF74 ¹	25	3,058	Band 0 - Not used Band 1 - 80 (79 data, 1 replacement) Band 2 - 90 (89 data, 1 replacement) Band 3 - 120 (119 data, 1 replacement)

¹The RF72 and RF73 ISEs use only 21 of 22 available disk surfaces and the RF74 ISE uses only 25 of 26 available disk surfaces. The surface with the most media defects is marked unusable at manufacture. Although the unused surface varies from ISE to ISE, this fact is transparent to the user, the operating system, and most utilities.

Drive Module

The drive module combines the functions of disk controller and drive electronics onto a single, surface-mount-technology printed circuit board.

Each drive module has a ready and a fault LED. The RF31/31F drive module uses a green ready LED and a red fault LED. The RF35/31T, RF36, RF72, RF73, and RF74 ISEs use green ready and amber fault LEDs surface mounted on the drive module.

Interfaces

Figure 2-2 shows the interfaces on the RF31 drive module and Figure 2-3 shows the interfaces on the RF35 drive module.

Figure 2-2 RF31/RF31F Drive Module Interfaces

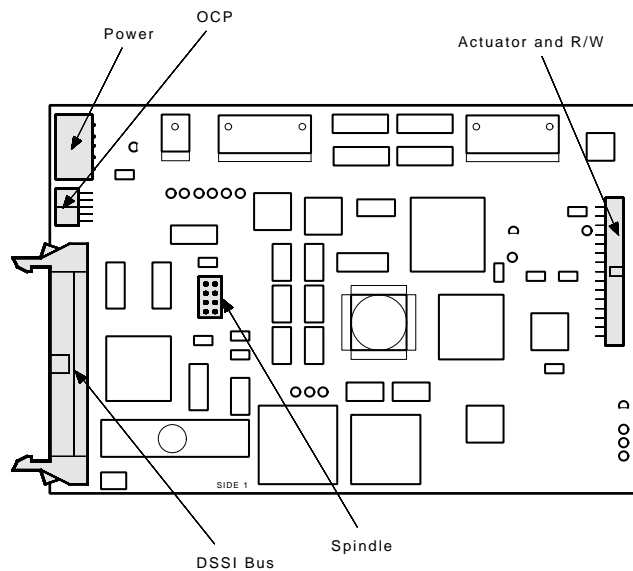

SHR_X1050B_89

Figure 2-3 RF35/RF31T Drive Module Interfaces

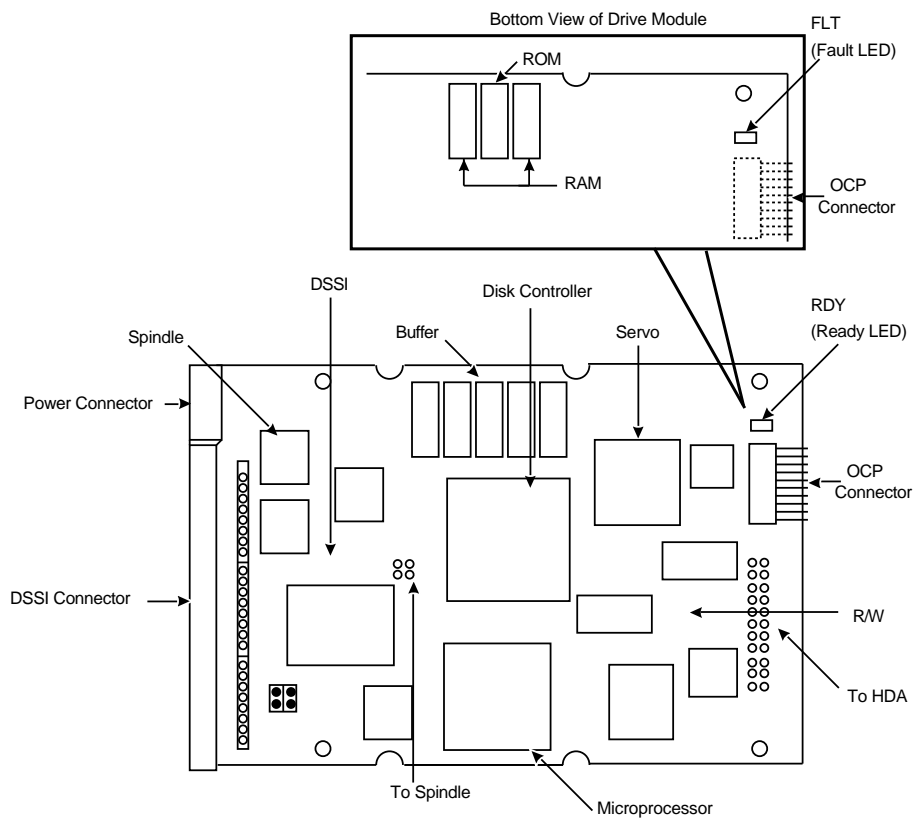

Interface Functions

As shown in previous figures, each interface is a connector. Table 2-1 describes the function of each RF31 drive module interface.

Table 2-1 RF31/RF31F Interfaces

Interface	Description	Function
DSSI bus	50-pin flat cable connector	Connects ISE to DSSI bus
Power	5-pin Molex connector	Connects +5V, +12V, and POK to ISE
OCP	10-pin flat cable connector	Connects ISE to operator control panel
Actuator and R/W	34-pin flat cable connector that mates to the flexible circuit strip from the HDA	Connects ISE to read/write preamps and to rotary positioner
Spindle	10-pin DIP connector that mates to the HDA	Connects spindle motor to drive module

Table 2–2 describes the function of each RF35 drive module interface.

Interface	Description	Function
DSSI bus	50-pin flat cable connector	Connects ISE to DSSI bus
Power	5-pin Molex connector	Connects +5V, +12V, and ACLO to ISE
OCP	20-pin bulkhead connector	Connects ISE to operator control panel
Actuator and R/W	22-pin connector	Connects ISE to rotary positioner
Spindle	4-pin DIP connector that mates to the HDA	Connects spindle motor to drive module

Functional Description

Drive Module Electronics

To understand the drive module, think of it as being divided into six major functional areas (Figures 2-4 and 2-5). Large-scale integration is used extensively, so the function of an area typically includes the function of one or a few of the chips in the corresponding area.

Figure 2-4 RF31 Drive Module Electronics

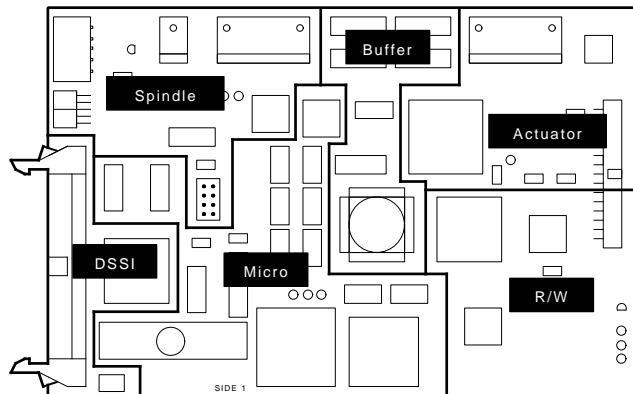

SHR_X1050A_89

Figure 2-5 RF35/RF31T Drive Module Electronics

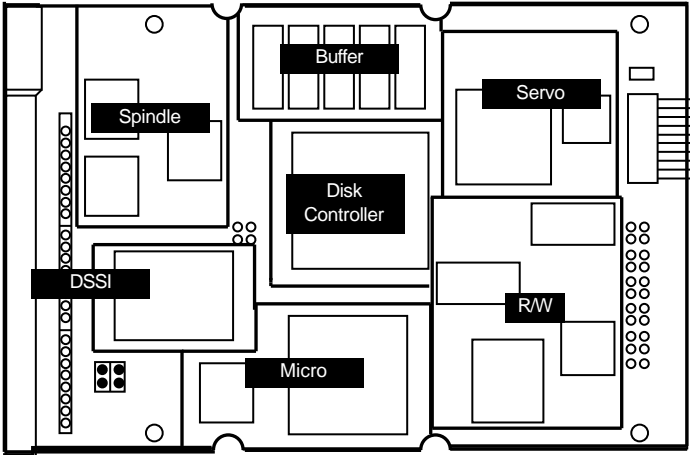

Divided Area Functions

The following table describes the function of each divided area in Figures 2-4 and 2-5.

Area	Function
Micro	The on-board intelligence resides here, in a firmware driving an MC680x0 microprocessor with static scratchpad RAM and nonvolatile RAM.
DSSI	A single chip (Swift) interfaces the Micro area to the DSSI bus. It provides a queued-packet interface to the Micro area, segregates data from commands, and generates and checks error detection codes.
Buffer	A single chip acts as a 3-port RAM controller, serving the static RAM as a data buffer and read cache for the Micro, R/W, and DSSI areas. Most of the digital R/W tasks, such as ECC generation and checking, are also done by this chip.
Spindle	This circuitry manages the spin-up and speed regulator.
Actuator	This circuitry activates active and passive controls the rotary positioner uses to maintain the position of the heads over a track.
R/W	This circuitry handles the remaining digital and analog read/write chain.

Drive Module Block Diagram

Figures 2-4 and 2-5 show how the drive module is laid out. Figure 2-6 is a block diagram of the same module including interfaces, areas, and functions.

Figure 2-6 Drive Module Block Diagram

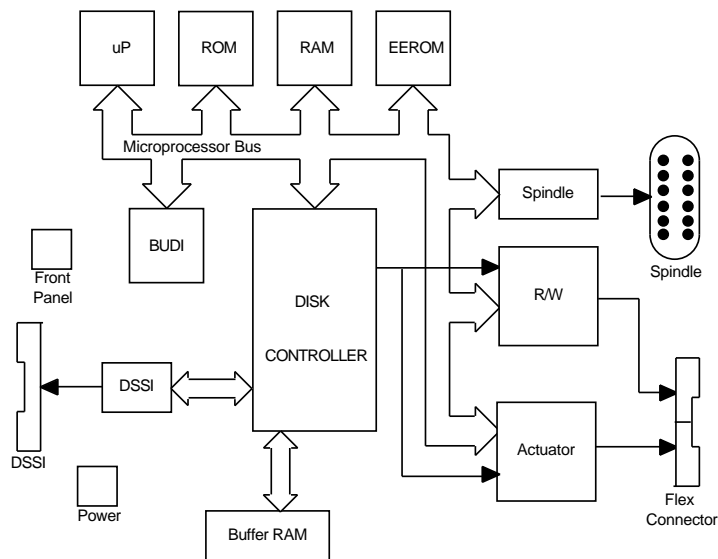

Data Flow

The microprocessor bus connects almost every functional area (Figure 2-6). However, the microprocessor is not directly involved with the data flow.

The buffer RAM collects and temporarily stores data. The disk controller chip performs I/O operations using the R/W hardware.

Figure 2-7 shows the data flow.

Figure 2-7 Data Flow Through the Drive Module

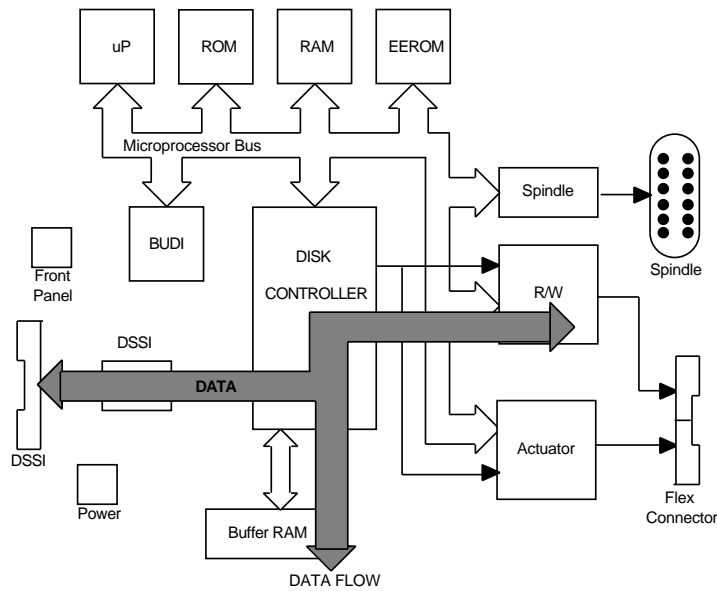

Data Protection

The following table describes how data is protected while traveling through the drive module.

Stage	Description
1	The Swift chip in the DSSI area generates and checks DSSI parity and error detection code (EDC).
2	Another EDC is generated and appended to each 512-byte block of data to protect the data in buffer RAM.
3	This EDC travels with the data through the disk controller chip, where the 264-bit ECC is generated before the data is written to the media.
4	The block number where the data was written is "added" to the Swift-generated EDC, further protecting against media-addressing errors.
5	The ECC is checked as data is being read from the media while the block number, where the data should be located, is "subtracted" from the EDC.
6	The EDC is then checked after the DSSI parity and EDC are generated by the DSSI area, as the data is transmitted onto the DSSI bus.

Command Flow

Commands are segregated into packets by the DSSI area and stored in the buffer RAM. The microprocessor then copies these commands (typically 36 bytes or less) into its local RAM before it acts on them.

As commands are completed, the process is reversed.

Figure 2-8 shows how commands are routed through the drive module.

Figure 2-8 Command Flow Through the Drive Module

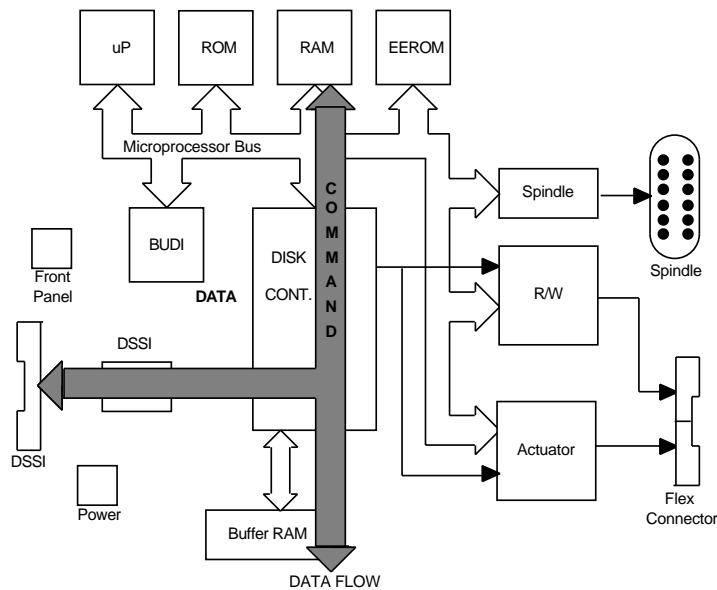

Command Protection

The following table describes how commands are protected while traveling through the drive module.

Stage	Description
1	On the DSSI bus, parity and EDC are appended to the commands.
2	The Swift chip in the DSSI area checks and generates DSSI parity and EDC.
3	The Swift chip generates an EDC to protect the commands during their short stay in the buffer RAM.
4	The microprocessor copies the commands to its parity-protected scratchpad RAM, while EDC is generated.
5	After the copy is complete, the microprocessor compares the EDC in the Micro area with the EDC generated by Swift.
6	When commands are transmitted out to the DSSI bus (such as the end packet for an I/O operation), the process is reversed.
7	The EDC is generated by the BUDI chip when the microprocessor copies the command to the buffer RAM.
8	This EDC is checked by the Swift chip after it generates the DSSI bus parity and EDC, as the command is transmitted onto the DSSI bus.

Firmware

Introduction

The ISE is called an integrated storage element because the drive, controller, and even some host functions are all integrated into the same package.

Figure 2-9 shows the firmware structure that makes the integration possible.

Figure 2-9 Firmware Structure

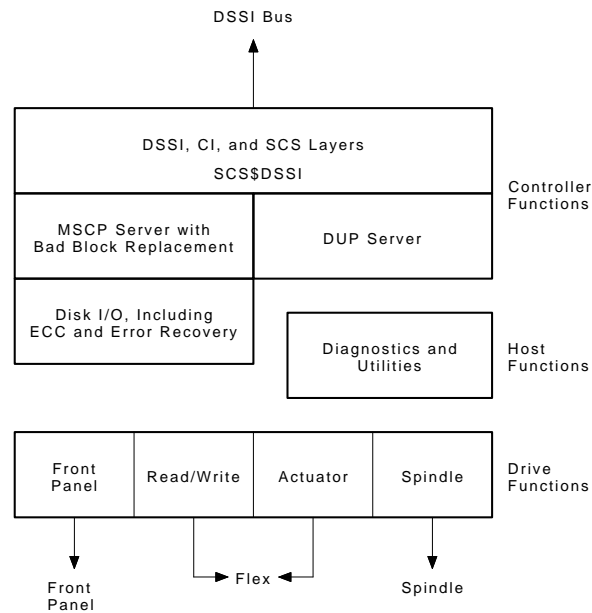

SHR_X1055_89

Firmware Structure

Several aspects of the ISE firmware structure are not shown in Figure 2–9. For example, a mini operating system runs the multiple programs in the ISE. Most of the firmware is coded in C, and a C run-time library is included.

Initialization

At initialization, power-on self-tests check the various chips on the module, start the spin-up sequence, and so on. Periodic diagnostics and calibrations adjust the servo and R/W systems for changing conditions.

STATUS THREADS Command

The programs that run in the ISEs are displayed when you access the PARAMS local program and type the STATUS THREADS command.

The following is an example of such a display.

```
PARAMS>STATUS THREADS
Pid  TCB Addr  Process Name  WQ Addr  State Pri    CPU
  0  FFFFB52C  NULL          00000000  RDY  255 0 00:06:49.46
  1  FF840C06  PERIODICS     FFFF9F74  BLK  254 0 00:00:16.10
65  FF8414A4  PRFMON       FFFFB57A  IDL  130 0 00:00:00.00
67  FF841544  DRVEXR       FF8415F4  IDL  124 0 00:00:00.00
68  FF841594  DRVTST       FF841544  IDL  121 0 00:00:00.00
69  FF8415E4  HISTORY      FF841594  IDL  118 0 00:00:00.00
70  FF841634  DIRECT       FF8415E4  IDL  115 0 00:00:00.00
71  FF841684  ERASE        FF841634  IDL  112 0 00:00:00.00
72  FF8416D4  VERIFY       FF841684  IDL  109 0 00:00:00.00
73  FF841724  DKUTIL       FF8416D4  IDL  106 0 00:00:00.00
74  FF841774  PARAMS       FFFFB582  CUR  103 0 00:00:03.54
  2  FF841814  MSCP$DUP     FFFFA3E6  TIM   28 0 00:00:01.17
  3  FF8420C8  SCS$DIRECTORY FFFFA516  BLK   25 0 00:00:00.07
  5  FF8431AA  MSCP$BBR     FFFFA3CA  BLK   19 0 00:00:00.00
  6  FF8439FA  PPT$DISK     FFFF8B7A  BLK   16 0 00:00:01.37
  7  FF84424A  SCS$DSSI     FFFF9FDE  BLK   13 0 00:00:02.09
  8  FF8488CE  MSCP$DISK    FFFFA17A  BLK   10 0 00:00:00.00
```

Thread Interfaces

The threads listed in the above example correspond to the firmware layers shown in Figure 2–9. For instance, the DSSI, CI, and SCS layers are implemented by the SCS\$DSSI thread. The SCS\$DSSI thread interfaces the DSSI hardware to the system applications (SYSAPs) that run in the ISE.

Communication Services

For each application, SCS\$DSSI provides communication services to the other nodes on the bus. The two important SYSAPs are directly beneath the SCS\$DSSI in Figure 2–9: the disk MSCP server described on the next page and the diagnostic and utility protocol (DUP) server described in the Diagnostics and Utilities section of this chapter.

MSCP Server

The MSCP server is implemented by the MSCP\$DISK thread, and the bad block replacement layer is implemented by the MSCP\$BBR thread.

Multihost Server

The MSCP server is a multihost server because it can maintain a command dialogue with multiple hosts at the same time. I/O commands received from all hosts are combined to form a seek-ordered list of commands.

Figure 2-10 shows a multihost server.

Figure 2-10 Multihost Server

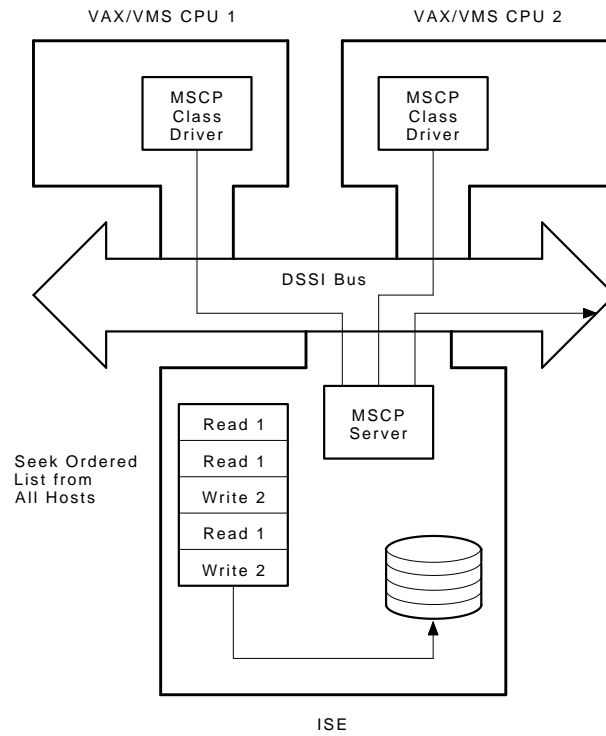

SHR_X1056A_93

Seek Ordering

A seek-ordered list of commands determines the order of command execution that minimizes the amount of time the drives spend seeking. Since seek time is typically the largest component of the total access time, seek ordering improves overall performance.

Request Fragmentation

To minimize the effects of rotational latency, the disk I/O firmware uses request fragmentation. Request fragmentation works by cutting up a long transfer into smaller pieces, and then completing the smaller pieces optimally. Although access to data on the disk is serial, DSSI provides random access to buffer memory.

Example Fragmentation

Assume, for example, that a full track read is issued to the ISE. The request is broken up into fragments (Figure 2–11). Each fragment is delivered to the host as it is read, so that the apparent rotational latency is only .07 revolutions, as opposed to the expected .50 revolutions.

Figure 2–11 Request Fragmentation

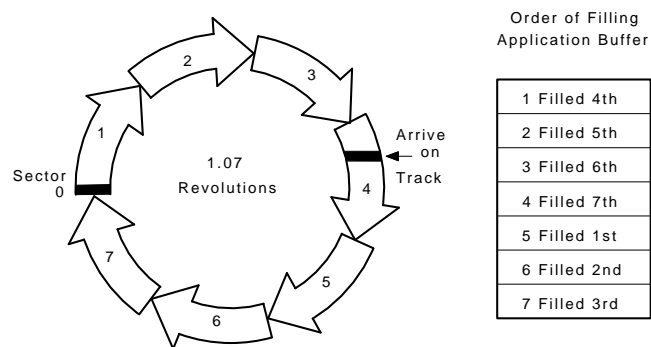

SHR_X1058A_89

Read Cache

To further reduce latency, the disk I/O firmware manages a multitrack read cache. After a request is satisfied, the sectors on the current track are read into one of the track lines in the cache unless a new command preempts this read operation. If the firmware detects that contiguous blocks are being read, the next track is also pre-read. Write requests try to disturb the cache as little as possible by using the least recently used (LRU) track line(s).

RCT Caching

The MSCP server caches the entire replacement control table (RCT). The RCT contains the list of bad blocks and the replacement block numbers (RBNs) that hold the data for each bad block in the list. In the past, tertiary replacements (those made to an RBN not on the track of the defective LBN) caused the controller to seek to the RCT to locate the RBN.

With RCT caching, the performance impact of tertiary revectorors is greatly reduced (Figure 2-12).

Figure 2-12 RCT is Cached in Controller RAM

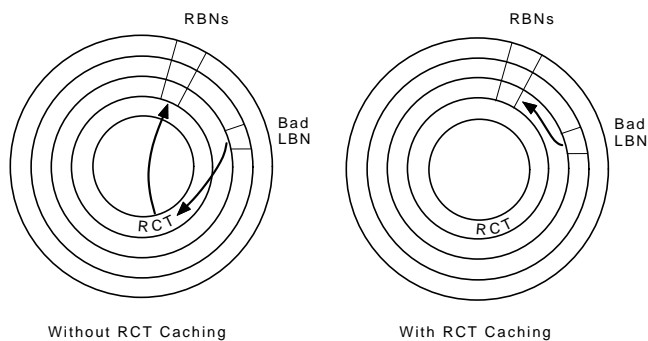

SHR_X1057_89

Sector Format and Error Handling

Introduction The PPT\$DISK also implements many other functions including error recovery and ECC correction.

Disk Sector Format The format of each disk sector (Figure 2–13) helps explain error handling.

Figure 2–13 RF31 Sector Format

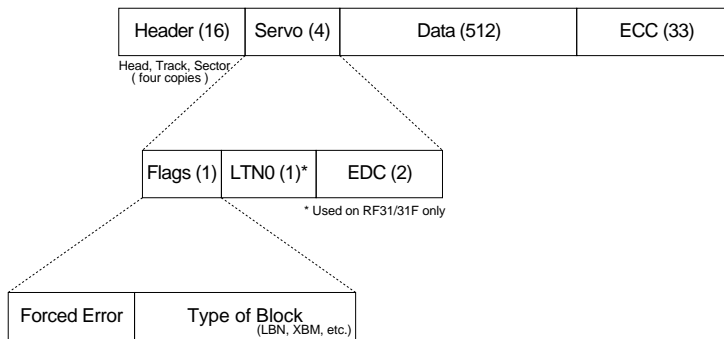

Sector Header Process

The following table lists the stages of the sector header process.

Stage	Description
1	Each sector header has four copies of its address (head, track, and sector number).
2	Firmware instructs the disk controller chip to match three out of four copies prior to a read or write operation.
3	If the header compare fails on a write operation, the block is replaced.
4	If the header compare fails to match three copies on a read operation, it attempts to match two copies.
5	Once the data is recovered, the block is replaced.
6	Note that the header is read only and represents the physical address of the block.

R/W Portion of Block	The read/write portion of the block starts with the four-byte Flags field, then contains the customer data in 512 bytes, and ends with a 33-byte ECC field.
Flags Field	The flags byte contains the forced error indicator and the type of block. The forced error indicator is a bad data mark. It means that the data is logically “bad” even though the sector it resides in may be defect-free.
LTN0 Field	The LTN0 (RF31/31F only) field is used to compensate for head and track scatter. The heads on the head stack are not aligned above one another. In fact, the tracks themselves are not aligned above one another. (See Figure 2–14.) The value in the LTN0 byte is the physical track number of the head that is directly above or below the LTN0 track for all other heads. (See Figure 2–15.)
EDC Field	The value in the EDC field is what is generated by the Swift chip when the data arrives over the DSSI bus with the block address “added” to it. This value is checked when the data is sent to the host.
ECC Field	ECC is one of the error recovery mechanisms. ECC covers both Flags and Data fields and can correct up to 15 bytes in a single sector. However, a much lower error threshold (number of bytes in error in the sector) causes the block to be replaced to ensure that plenty of correction capability remains in the ECC.

Head and Track Scatter Compensation

Figure 2-14 illustrates head and track scatter compensation in the LTN0 field used in the RF31/31F only.

Figure 2-14 Head and Track Scatter Compensation

Logical Track Zero (LTN0) Corrects This:

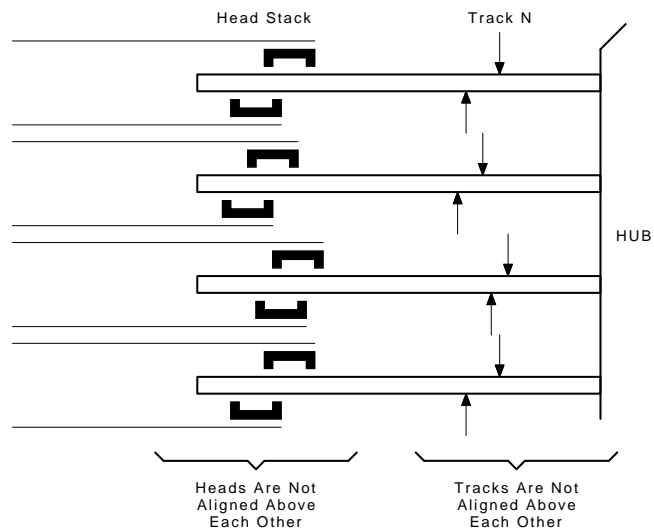

SHR_X1060_89

**LTN0 Track
Reference Point**

To improve performance and retain the concept of a cylinder (a vertically aligned set of tracks), the RF31/31F defines a track reference point for each head. The value in the LTN0 byte is the physical track number of the head that is directly above or below the LTN0 track for all other heads. This LTN0 track is the reference point for each surface (Figure 2–15).

Figure 2–15 On-Disk Format Anchored at LTN0 on Each Surface (RF31/31F)

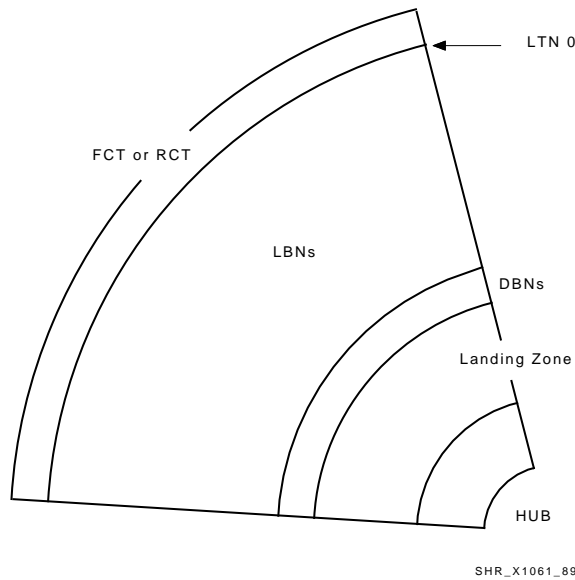

Diagnostics and Utilities

Introduction The rectangle labeled Diagnostics and Utilities in Figure 2–9 represents those user-accessible programs that run under the diagnostic and utility protocol (DUP) server. These programs are listed later in this section, and are described in greater detail.

POST The other diagnostic program that runs at system initialization is called power-on self-test (POST). The POST firmware tests the hardware on the drive module and in the HDA, and achieves almost complete coverage.

POST Coverage The only hardware not verified by the POST is a small part of the DSSI area (shaded part of Figure 2–16). This part of the module is verified by the ISE's ability to communicate with the host.

Figure 2–16 POST Coverage (RF31 shown)

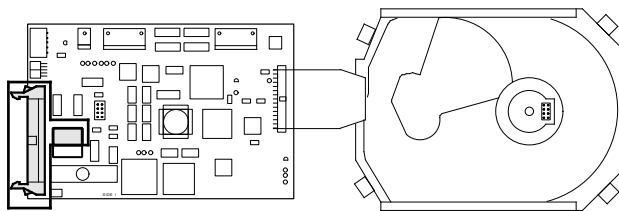

SHR_X1062_89

POST Verifications

POST, and the diagnostics and calibrations that run after head load, verify:

- That each head in the HDA works
- That the drive can seek across all tracks
- That each head can read and write correctly

Once POST has run successfully, you need only access the drive over the DSSI bus to achieve full diagnostic coverage.

After POST

After POST runs, the diagnostic tasks are picked up by the PERIODICS thread and by the DUP server (MSCP\$DUP thread). The PERIODICS thread invokes POST diagnostics and runs calibrations on the drive periodically. This process is automatic, running as the lowest priority thread in the system.

DUP Server

You can think of the DUP server as a window into the ISE-resident diagnostic and utility programs. Like the MSCP server, the DUP server is a multihost server, allowing several diagnostic and utility programs to run in the ISE at the same time (Figure 2-17). The RF31, RF35, RF36, RF72, RF73, and RF74 ISEs include nine diagnostic and utility programs.

Figure 2-17 Multihost DUP Server

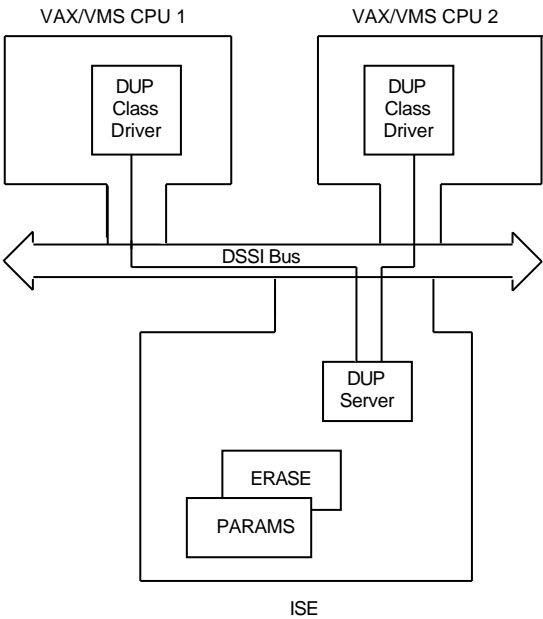

Diagnostic and Utility Programs

The nine diagnostic and utility programs resident in each ISE can be broken down into three categories:

- Management utilities
- Diagnostics
- System-level utilities

Figure 2–18 shows how the programs are categorized.

Figure 2–18 Diagnostics and Utilities

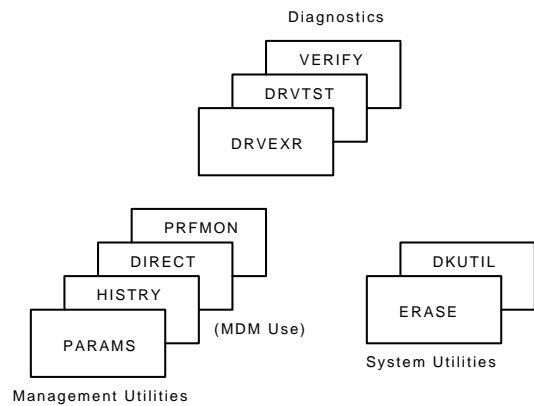

SHR_X1064_89

Program Descriptions

The following table briefly describes each program.

Category	Program	Description
Management utilities	PARAMS	A SYSGEN-like parameter editor and interactive query utility used to view ISE and DSSI bus status.
	HISTORY	An abbreviated version of a portion of PARAMS. HISTORY is used by host-level software such as MDM.
	DIRECT	A directory program, output only, that lists the available diagnostic and utility programs.
	PRFMON	An abbreviated version of a portion of PARAMS. PRFMON can be used by host-level software such as the VAX performance analyzer (VPA).
Diagnostics	DRVEXR	A comprehensive drive exerciser.
	DRVTST	A quick pass/fail test of the drive.
	VERIFY	A complete read check of the disk and verification of the DSDF ¹ on-disk structure.
System-level utilities	ERASE	A data “scrubber” utility that writes alternating patterns to each LBN, including the second sector of the RCT and the previous locations of the bad blocks, and then verifies that the scrubbing process succeeded.
	DKUTIL	An interactive block display and replace utility. Typically used to confirm ERASE scrubbing.

¹DEC Standard Device Format specification

Detecting Errors

The ISE makes errors visible in a variety of ways. Knowing where to look for errors helps you to communicate with Digital Customer Services personnel.

If the controller portion of the ISE is not functioning, the fault LED on the drive module and the fault LED on the operator control panel turn on (Figure 2–19). Also, the ISE is not visible on the DSSI bus. The failing component, in this case, is the drive module itself, because it houses the controller electronics.

Figure 2–19 Location of the Fault LEDs (RF31 Shown)

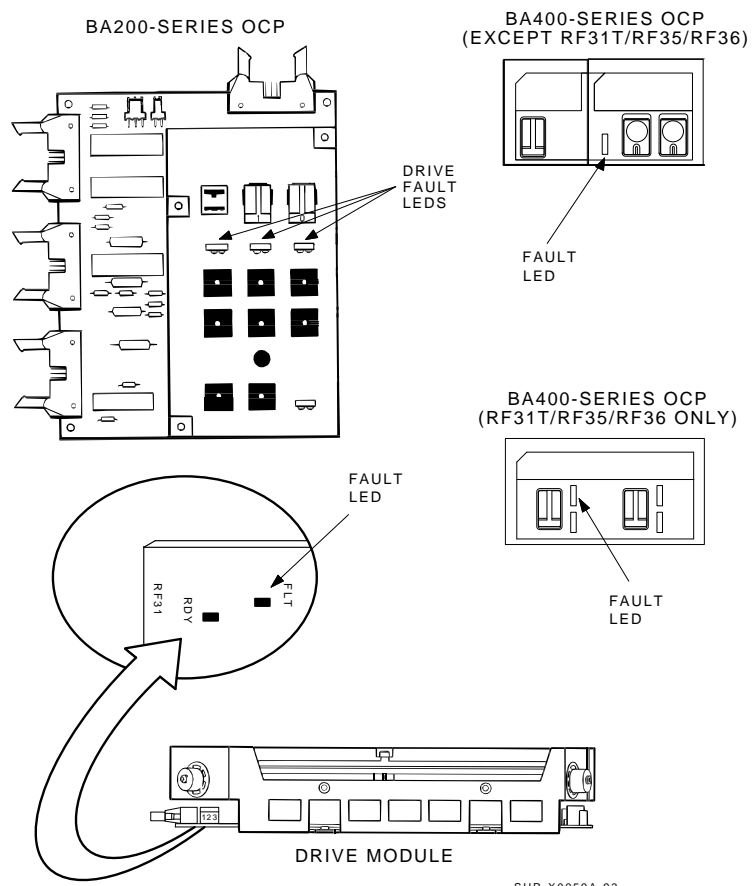

Detecting Errors Using PARAMS

If the controller portion of the ISE passes diagnostics but the unit portion does not, the fault LED still turns on. However, (because the controller is operational), the ISE *is* visible on the DSSI bus and can be queried to further resolve the error condition. At this point, the fault may be within the unit electronics or the HDA.

Error Codes

To obtain an error code, use the PARAMS utility program as shown in the following example.

```
PARAMS> STAT CONF
Node R1WSRA is an RF31 controller
Software RFX X200 built on 8-AUG-1989 03:38:51
Electronics module name is EN83804656
Unit is inoperative, error code 9802(X)
Last known unit failure 9802(X)
In 1275 power-on hours, power has cycled 767 times
System time is 19-AUG-1989 18:13:33
```

In the example, the unit error code is 9802(X). This is also shown as the last known error (stored in nonvolatile RAM). These error codes are defined in the service guide. Your Customer Services representative uses them to determine the field replaceable unit (FRU) most likely to have failed.

Fatal Error

The errors described above are usually fatal. That is, once the error occurs, the fault LED stays on and the ISE is not usable until the error condition is corrected.

Transient Errors

Transient errors, however, can also occur. For example, a bit in RAM can flip, or an address collision can occur on the DSSI bus. The most recent transient errors (up to 11) are kept in a log in nonvolatile RAM, which is accessible through the PARAMS utility program.

Error History

To access this error history, use the STAT LOG command as shown in the following example.

```
PARAMS> STAT LOG
Log History:
Log #000-2B-73-07/0000 21-AUG-1989 13:22:04
FFFF8450 FFFFB354 4E554E55 4E554E55 4E554E55 4E554E55 4E554E55 0000AA01
FF80C1B0 FF80C1B0 000029F6 4E554E55 FF817D5E FFFF83BE 4E554E55 FFFF96BC
5CABF380 009239C1 00002EA0
```

The primary users of the error history are module repair personnel. The error history may also serve as an indication to Customer Services personnel that the system is configured incorrectly or that the drive module should be replaced.

Detecting Soft Errors

Introduction Soft errors may be caused by external environmental factors (for instance, temperature or shock) or errors that are expected to occur throughout the lifetime of the product (such as an infrequent bad block replacement). These errors are reported in MSCP error logs.

MSCP Error Logs MSCP error logs are displayed by the error log report generators of many different operating systems. These logs are analyzed by the VAXsimPLUS program to predict failures.

Error Log Summary The ISE produces three kinds of error logs, as summarized in the following table.

MSCP Error Log	Reason Generated
Read/Write Error Log	Any failure to read or write (above certain thresholds).
Bad Block Replacement Summary	Any time a read/write error log is generated, this log summarizes the attempt to replace the "bad" block.
Servo Performance Warning	If, during the past hour, the servo system suffered more than its threshold of performance hits.

Soft Errors not Reported

Certain soft errors are not reported in logs. For example, a single symbol (byte) error on a read is corrected, but not reported.

The threshold for reporting an error (and replacing the block) in the case of an ECC error on a read command is three. This means that until three or more symbols are corrected in a block, the block is not replaced. Three symbols in error is well within the safety margin of the ECC. The ECC can correct up to 15 symbols in error in a single block.

Controls and Indicators

Introduction

In this Chapter

This chapter describes the controls and indicators associated with ISE operation. The controls and indicators are located in two places:

- Operator control panel on the system enclosure
- ISE drive module

OCP

The operator control panel (OCP) is a set of controls on the enclosure that overrides the ISE's switches or jumpers and enables the operator to set the DSSI node ID and write-protect mode for the ISE.¹ The OCP also contains a fault LED that indicates if the ISE is malfunctioning.

The following table compares the OCPs in the BA200 and BA400 series enclosures.

In the ...	an OCP ...
BA200 series enclosures	contains three identical sets of controls and indicators, one set for each ISE that may be connected to it.
BA400 series enclosures	is contained on each ISE and is mounted on a panel in front of the ISE.

¹ There are no controls for 3½-inch devices in BA400 series enclosures. Write protect is accomplished through software commands.

BA200 Series Controls and Indicators

OCP

The BA200 series enclosures each have a standard DSSI OCP. Figure 3-1 shows controls and indicators on the OCP.

Figure 3-1 BA200 Series DSSI Operator Control Panel

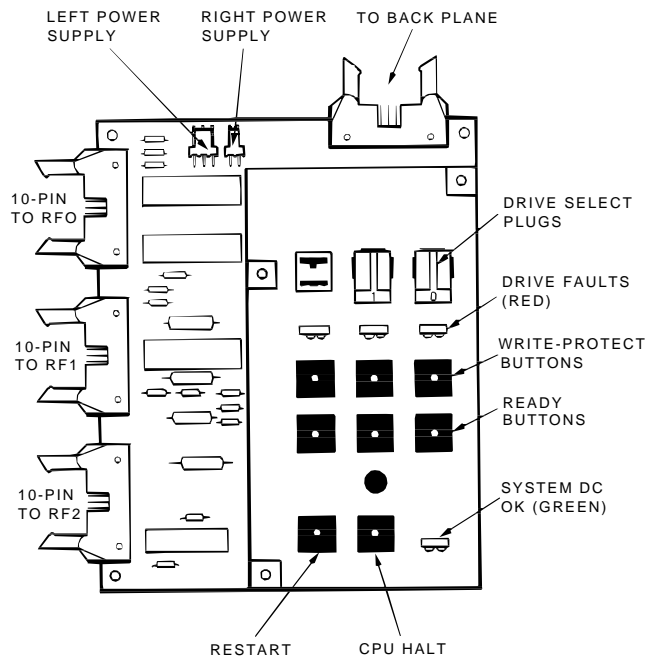

MA-X0965-88
SHR_X1053_88_SCN

OCP Controls

The following table describes the function of the three drive controls on the BA200 series DSSI operator control panel.

Control	Status	Function
Drive Select Plug	Installed	Sets the DSSI node ID to the number specified on the plug. A drive select plug must be installed for every ISE connected to the OCP.
	Removed	Causes a fault condition. The drive fault LED flashes at 10 Hz. DSSI node ID is undefined.
Write-Protect Button	Out	Enables the system to read and write to the media (normal operating position).
	In	Causes the system to be write-locked, the system can only read from the media.
Ready Button	Out	Puts the ISE on line (normal operating position).
	In	Puts the ISE off line.

OCP Indicators

The following table gives the meaning of each indicator on the BA200 series DSSI operator control panel.

Indicator	Status	Meaning
Fault LED	On	Fault condition present (except during POST).
	Off	No fault present (normal operating condition).
	Slow flash (5 Hz)	Internal ISE calibrations are being performed.
	Quick flash (10 Hz)	OCP failure, or drive select plug is missing.
Write-Protect LED	On	Write-protect enabled.
	Off	Write-protect disabled.
Ready LED	On	ISE is on line and ready.
	Off	ISE is off line.
	Flashing	Drive is active.

BA400 Series Controls and Indicators

OCP

Each ISE installed in a BA400 series enclosure has a front panel with the following controls and indicators.

- DSSI bus node ID plug
- Fault LED
- Write-protect button (not for RF35/RF31T or RF36 ISE)
- Run/Ready button (not for RF35/RF31T or RF36 ISE)

Figure 3–2 shows two different front panels for the BA400 series enclosure.

Figure 3–2 BA400 Series OCP for DSSI ISEs

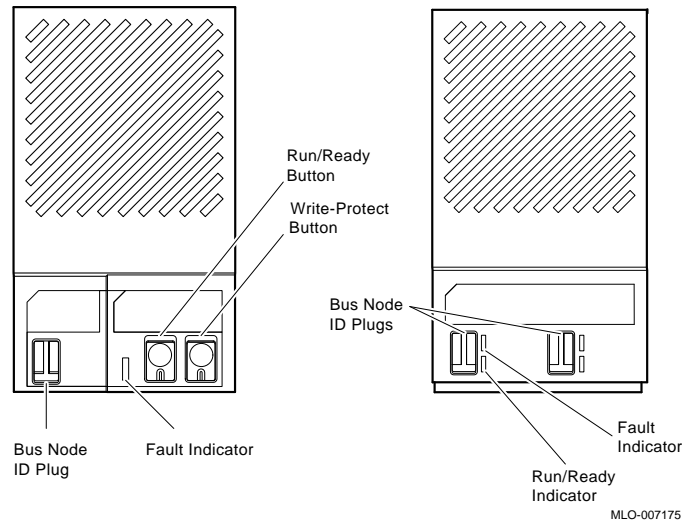

Control and Indicator Functions

The following table describes the function of the controls and indicators on the BA400 series DSSI operator control panel.

Control	Status	Function
Fault LED	On	Indicates an error condition within the ISE.
	Off	Indicates an error-free condition within the ISE.
Run/Ready Button ¹	In (on)	The ISE is on line. When the ISE is available for use, the green LED is on. When the ISE is being used, the green LED flashes.
	Out (off)	The ISE is off line and cannot be accessed. The green LED cannot be on when the Run/Ready button is out.
Write-Protect Button ¹	In (on)	The ISE is write-protected. System software cannot write to the ISE.
	Out (off)	The ISE is not write-protected. This is the normal position for software operation. System software is free to read or write to the ISE.

¹Button not present on RF35/RF31T or RF36 OCP. Refer to RF35/RF31T and RF36 Write-Protection.

**RF35/RF31T
and RF36
Write-Protection**

In a BA400 series enclosure . . .

You may want to write-protect an ISE containing sensitive data you do not want changed or accidentally erased.

Your system disk (the ISE containing system software) and ISEs containing work areas for users should be write-enabled, the normal operating setting.

For the RF35/RF31T and RF36 ISE, you set write-protection through VMS commands or through firmware commands in console mode. This is explained later in this section. The BA400 series OCP for the RF35/RF31T and RF36 does not have a write-protect button.

Software Write-Protect for RF35/RF31T and RF36 ISEs

Software write-protect is available through VMS using the MOUNT utility with the /NOWRITE qualifier.

To software write-protect an ISE, enter the following DCL command from the VMS operating system.

```
MOUNT <device_name> <volume_label>/SYSTEM/NOWRITE
```

Where:

<device_name> is the device name, as shown using the VMS DCL command SHOW DEVICE DI, and <volume_label> is the volume label for the device. For example,

```
$ MOUNT $1$DIA1 OMEGA/SYSTEM/NOWRITE
```

will software write-protect device \$1\$DIA1.

Dismounting, and then remounting the device (without using the /NOWRITE qualifier), will write-enable the device.

Use the VMS DCL command SHOW DEVICE DI to check the protection status of the drive. A write-protected drive will show a device status of "Mounted wrtlck". Refer to your VMS documentation for more information on using the MOUNT utility.

Caution

When you dismount, and then mount the device again, it is no longer write-protected.

Hardware Write-Protect for RF35/RF31T and RF36 ISEs

Hardware write-protect provides a more permanent write-protection than software write-protect. Once you hardware write-protect an RF35/RF31T or RF36 ISE, the ISE remains write-protected regardless of the availability of the operating system or the state of system power.

In addition, hardware write-protect cannot be removed using the MOUNT command. Hardware write-protect simply provides the same degree of write-protection available to RF series ISEs with write-protect buttons.

Consider hardware write-protecting an RF35/RF31T or RF36 ISE in the following situations:

- If you want to write-protect an RF35/RF31T or RF36 ISE when the VMS operating system is unavailable, such as before running the MicroVAX Diagnostic Monitor (MDM).
- If you want to ensure that an RF35/RF31T or RF36 ISE remains write-protected, since the hardware write-protect cannot be removed using the VMS command MOUNT and will remain in effect even if the operating system is brought down.

You can hardware write-protect an RF35/RF31T or RF36 ISE from VMS or through firmware commands entered at the console prompt (>>>). Use the following instructions:

1. Access the Diagnostic and Utility Program (DUP) driver for the device you want to write-protect.
 - To access the DUP driver from console mode:
 - a. Enter console mode by pressing the halt button or powering up the system with the break enable/disable switch set to enable (up, position 1).

Caution

Halting your system without following the shutdown procedure described in your system software manuals may result in loss of data.

- b. Access the DUP driver by setting host to the specific device you want to write-protect.

Use the following command for embedded DSSI:

```
SET HOST/DUP/DSSI/BUS: <bus_number>  
<node_number> PARAMS
```

Where:

<bus_number> is the DSSI bus number (0 or 1),
and <node_number> is the bus node ID (0–6) for the
device on the bus (bus number and node number are
listed in the SHOW DSSI display).

Use the following command for KFQSA-based DSSI:

```
SET HOST/DUP/UQSSP/DISK <controller_number> PARAMS
```

Where:

<controller_number> is the controller number (listed
in the SHOW UQSSP display) for the device on the
bus.

- To access the DUP driver from VMS:
 - a. Connect to the DUP and load its driver using the VMS System Generation Utility (SYSGEN) as shown below:

```
$ MCR SYSGEN
SYSGEN> CONNECT/NOADAPTER FYA0
SYSGEN> EXIT
$
```

- b. Access the DUP driver by setting host to the specific device you want to write-protect. Use the following command:

```
SET HOST/DUP/SERVER=MSCP$DUP/TASK=PARAMS <node_name>
```

Where:

<node_name> is the device node name (the node name, in parentheses, is listed in the SHOW DEVICE DI display).

2. At the PARAMS> prompt, enter SET WRT_PROT 1 to write-protect the ISE to which you are currently connected.

Note

To verify that you have set host to the intended drive, you can enter the command LOCATE at the PARAMS> prompt. The LOCATE command causes the drive's fault indicator to flash momentarily.

3. Enter `SHOW WRT_PROT` to verify the `WRT_PROT` parameter is set to 1.
4. After you have finished setting and examining the `WRT_PROT` device parameter, enter the `WRITE` command at the `PARAMS>` prompt to save the device parameter. The change is recorded in nonvolatile memory.
5. Enter the `EXIT` command at the `PARAMS>` prompt to exit the DUP driver utility for the specified device.

Example 3-1 shows how to set hardware write-protect through firmware. Example 3-2 shows how to set hardware write-protect through VMS.

Example 3-1 Setting Hardware Write-Protection Through Firmware

```
>>>SET HOST/DUP/DSSI/BUS:0 1 PARAMS
Starting DUP server...
Copyright (c) 1992 Digital Equipment Corporation
PARAMS>SET WRT_PROT 1
PARAMS>WRITE
PARAMS>SHOW WRT_PROT
Parameter      Current          Default          Type          Radix
-----
WRT_PROT              1                0      Boolean      0/1
PARAMS>EXIT
Exiting...
Stopping DUP server...
>>>
```

Example 3–2 Setting Hardware Write-Protection Through VMS

```
$ MCR SYSGEN
SYSGEN> CONNECT/NOADAPTER FYA0
SYSGEN> EXIT
$ SET HOST/DUP/SERVER=MSCP$DUP/TASK=PARAMS R35F3C
Starting DUP server...
Copyright (c) 1992 Digital Equipment Corporation
PARAMS>SET WRT_PROT 1
PARAMS>WRITE
PARAMS>SHOW WRT_PROT
Parameter      Current      Default      Type      Radix
-----
WRT_PROT              1              0  Boolean  0/1
PARAMS>EXIT
Exiting...
Stopping DUP server...
$
```

To remove hardware write-protection, repeat the procedure but set the WRT_PROT value to 0.

You can verify that the device is write-protected while running VMS. When you issue the VMS DCL command SHOW DEVICE DI, a write-protected drive will show a device status of “Mounted wrtlck”. If you issue the VMS command SHOW DEVICE/FULL, a write-protected drive will be listed as “software write-locked”.

Note

You cannot remove hardware write-protection using the VMS MOUNT utility.

SF7x Enclosure Controls and Indicators

OCP

Each ISE in the SF7x storage enclosure is represented by an icon on the door located on the OCP. Each set of controls and indicators is dedicated to one of the four storage compartments in the enclosure (Figure 3-3).

Figure 3-3 SF7x Controls and Indicators

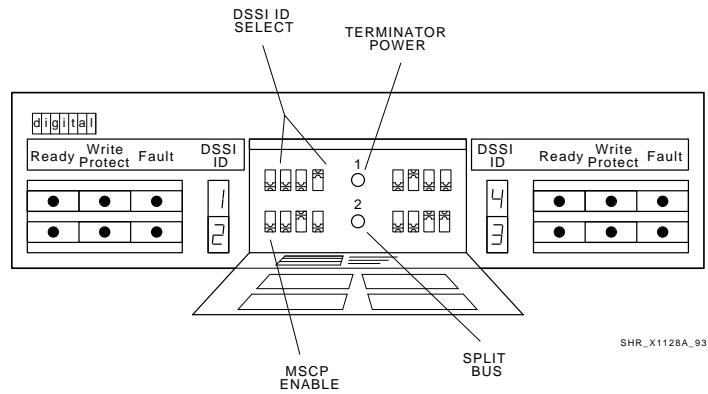

Control and Indicator Functions

The following table describes the functions of the controls and indicators on the SF7x enclosure DSSI OCP.

Control/Indicator	Color	Function
Ready	Green	Turns on when ISE is on line and read/write ready.
Fault	Red	Turns on when fault is detected.
DSSI Node ID	Green	Displays ISE DSSI node ID.
Write Protect	Yellow	Commands write-protect mode. Shows write-protect enabled.
Terminator Power	Green	On when terminator power is being supplied.
Split Bus	Green	On when enclosure is in split bus mode.
DSSI Node ID Select	N/A	3 bits, selects DSSI node ID number.
MSCP Enable/Disable	N/A	1 bit, enables or disables the ISE MSCP server.
DC power switches (4)	Green	Apply dc power to ISE. Show power status.

Changing the DSSI Node ID Plugs (BA200 and BA400 Series OCPs)

- Spare Plugs** Spare DSSI node ID plugs are supplied with your system. Use these spare plugs to renumber your DSSI system when you:
- Need to reconfigure because you add or remove ISEs
 - Create a multihost configuration
- Removal** The DSSI node ID plugs have prongs on the back that indicate the bus node number (and by default, the unit number) of the ISE. To remove a DSSI node ID plug, grasp it firmly and pull it straight out.
- Insertion** To insert a new plug, align the two center prongs with the two center slots and press the plug into the slots.
- Renumbering ISEs** Use the following rules to renumber your ISEs:
- For each DSSI bus, do not use duplicate DSSI node IDs.
 - By convention, ISEs are numbered in increasing order from right to left and top to bottom.
 - Use a blank DSSI node ID plug where no ISE is present.

Note

If you change the bus node ID plugs while the system is operating, you must turn off the system and then turn it back on for the new plug positions to take effect.

ISE Controls and Indicators

Description

The RF31/31F, RF72, RF73, and RF74 ISEs each have two LEDs and a DIP switchpack containing three switches mounted on the edge of the drive module. The RF35/31T, and RF36 ISEs each have two LEDs and an options connector mounted on the edge of the drive module. Jumpers are inserted into this connector. On the RF35/31T and RF36 ISE, this connector is located at the opposite end of the DSSI connector. On the RF72, RF73, RF74 and RF31/31F ISEs, this connector is located next to the power connector.

The switches (on the RF31/31F, RF72, RF73, and RF74 ISEs) and option connector (on the RF35/31T and RF36 ISEs) provide a means of setting the DSSI node ID if an OCP is not connected to the drive, or if the OCP fails.

The following two LEDs indicate drive status:

- Ready LED
- Fault LED

Figure 3–4 shows the location of the switches and LEDs on the drive module for the RF31/31F, RF72, RF73, and RF74 ISEs.

Figure 3–4 RF31/31F, RF72, RF73, and RF74 Drive Module Switch and LED Locations

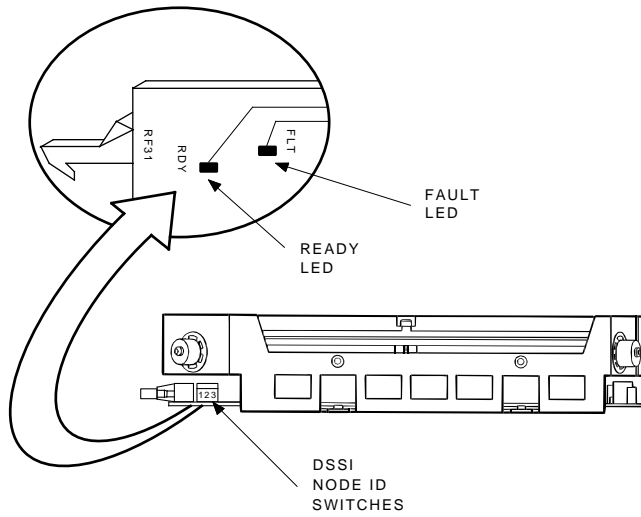

MA-X0967-88
SHR_X1065_89

Figure 3–5 shows the location of the options connector and LEDs on the drive module for the RF35/31T and RF36 ISEs.

**Figure 3-5 RF35/31T and RF36 Drive Module Options
Connector and LED Locations**

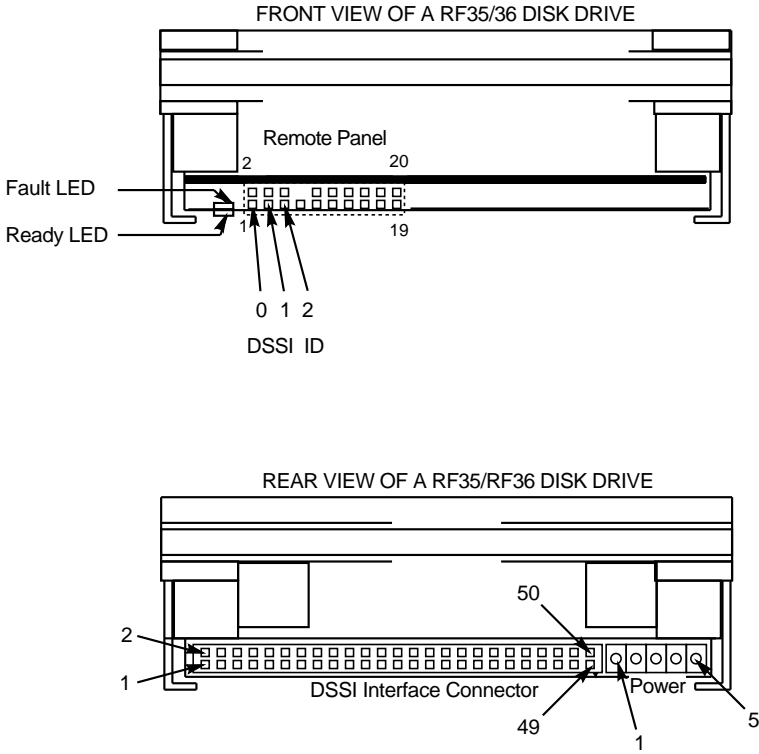

RF3x_front_back-rags

Assigning DSSI Node ID

Assignment of the DSSI node ID is done by setting the three switches to the binary equivalent of the selected ID number, as shown in the following tables. These switches are ignored when an OCP is connected to the ISE.

Table 3–1 RF31/31F, RF72, RF73, and RF74 DSSI IDs

DSSI Node ID Address	Switch Positions ¹		
	1	2	3
0	Down	Down	Down
1	Down	Down	Up
2	Down	Up	Down
3	Down	Up	Up
4	Up	Down	Down
5	Up	Down	Up
6	Up	Up	Down
7 ²	Up	Up	Up

¹Up is toward the HDA, down is toward the module.

²DSSI address 7 is normally assigned to a host adapter.

Table 3–2 RF35/31T and RF36 DSSI IDs

DSSI Node ID Address	Jumper ¹		
	1	2	3
0	Out	Out	Out
1	Out	Out	In
2	Out	In	Out
3	Out	In	In
4	In	Out	Out
5	In	Out	In
6	In	In	Out
7 ²	In	In	In

¹In = inserted, Out = removed.

²DSSI address 7 is normally assigned to a host adapter.

Drive Module LEDs

The two LEDs mounted on the drive module monitor ISE status during operation. The following table describes the state of these two LEDs during the various phases of ISE operation.

When . . .	The green LED is . . .	And the Fault LED is . . .
The ISE is first powered up	On	On
POST has run successfully	Off	Off
The read/write heads are on cylinder and ready	On	Off
The drive is active	Flashing	Off
A read/write or serious physical error is detected	Off	On

4

Local Programs

Accessing Local Programs

In this Chapter

This chapter covers the following topics:

- Accessing local programs through VMS, from the console, and through MDM
- Local programs that can be accessed

Overview

Local programs are diagnostics and utilities internal to the ISE. They are accessed in one of the following three ways, depending on the system you are using.

To access local programs ...	See page
Through VMS, using the SET HOST command,	4-3
From the console, using the SET HOST command,	4-4
Through MDM, using the Device Resident Programs menu,	4-6

Once a connection is established, operations are performed under the control of the local program. The following is a list of local programs found in this chapter:

Programs	See page
DIRECT	4-7
DRVEXR	4-8
DRVTST	4-10
HISTRY	4-12
ERASE	4-13
VERIFY	4-16
DKUTIL	4-22
PARAMS	4-39

When the program ends, control is returned to the system. To abort the program and return control to the system, press **Ctrl/C** or **Ctrl/Y**.

Using VMS

To access a local program from a MicroVAX system running VMS version 5.3-2 or later, the command is:

```
$ SET HOST/DUP/SERVER=MSCP$DUP/TASK=taskname nodename
```

Where:

taskname = name of the local program

nodename = node name of the ISE

Names and descriptions of the local programs are provided later in this chapter. To find the node name of an ISE, type SHOW DEVICES or SHOW CLUSTER at the \$ prompt and press

.

To produce a file in your directory of what appears on the screen, add the qualifier /log=filename.ext (where filename.ext is what you want to name the file) before you press .

Using Console Commands

Some systems allow you to access the local programs using console commands. The command you use depends on whether your system uses a Q-bus adapter like the KFQSA module, or an embedded adapter such as the KA640 module.

Q-bus Adapters

To access a local program from a system with a Q-bus adapter, the command is:

```
>>> SET HOST/UQSSP/DUP/DISK # taskname
```

Where:

taskname = name of the local program

= controller number of the ISE

To find the controller number, type SHOW UQSSP at the console prompt (>>>). An example of the SHOW UQSSP command is:

```
>>> show uqssp
UQSSP Disk Controller 0 (772150)
-DUA0 (RF31)

UQSSP Disk Controller 1 (760334)
-DUB1 (RF31)

UQSSP Disk Controller 2 (760340)
-DUC2 (RF31)

UQSSP Tape Controller 0 (774500)
-MUA0 (TK70)
>>>
```

Embedded Adapters

To access a local program from a system with an embedded adapter, the command is:

```
>>> SET HOST/DUP/DSSI/BUS:n #
```

Where:

n = bus number where the ISE is located

= DSSI node number of the ISE

The system prompts you for the name of the local program you want to run.

To find the DSSI node number and node name, type SHOW DSSI at the >>> prompt. To see a list of the devices on the Q-bus, type SHOW QBUS or SHOW UQSSP at the >>> prompt.

To abort the program and return control to the system, press

Ctrl/C or Ctrl/Y.

Using MDM

If neither VMS nor console commands are available on your system, you can run local programs using MDM. Use the following procedure:

1. Boot MDM.
2. Enter the date and time.
3. Select the menus in the following order:
 - Service menu
 - Device menu
 - KFQSAA-KFQSA subsystem menu
 - Device Utilities menu
 - Device Resident Programs menu

When you select the Device Resident Programs menu, the following is displayed:

```
RUNNING A UTILITY SERVICE TEST
```

```
To halt the test at any time and return to the previous menu,  
type CTRL-C by holding down the CTRL key and pressing the C key.
```

```
KFQSAA started.
```

```
KFQSAA pass 1 test number 3 started.
```

```
Copyright 1988 Digital Equipment Corporation  
Completed.
```

```
EXIT                DRVEXR                DRVTST  
HISTORY             ERASE                 PARAMS  
DIRECT              DKUTIL                PRFMON  
VERIFY
```

```
Please choose a local program or press <RETURN> to continue.
```

4. Type in the name of the local program you want to run and press `Return`. For information about the available local programs, refer to the program descriptions on the following pages.
5. To exit MDM, press the `Break` key.

Local Programs

Overview The rest of the chapter describes the local programs you can access.

DIRECT

Description DIRECT provides a directory of local programs resident in the ISE.

Example The following is an example of what is displayed when you run the DIRECT program.

```
Copyright © 1989 Digital Equipment Corporation
PRFMON  V1.0  D  21-AUG-1989  13:39:09
DRVEXR  V2.0  D  21-AUG-1989  13:39:09
DRVSTST V2.0  D  21-AUG-1989  13:39:09
HISTRY  V1.1  D  21-AUG-1989  13:39:09
DIRECT  V1.0  D  21-AUG-1989  13:39:09
ERASE   V2.0  D  21-AUG-1989  13:39:09
VERIFY  V1.0  D  21-AUG-1989  13:39:09
DKUTIL  V1.0  D  21-AUG-1989  13:39:09
PARAMS  V2.0  D  21-AUG-1989  13:39:09
Total of 9 programs.
```

DRVEXR

Description

DRVEXR is a diagnostic that applies several types of stress to the ISE.

You access DRVEXR the same way you access other local programs. Once a connection is established, the user is prompted to answer a series of questions. The responses determine the mode and test duration.

Stopping DRVEXR

To stop DRVEXR in progress, press `Ctrl/C`, `Ctrl/Y`, or `Ctrl/Z`. When DRVEXR stops, a short report is printed.

Dialogue

To run DRVEXR, you must respond to the following dialogue messages first:

Message	Explanation
Copyright © 1989 Digital Equipment Corporation	No response is expected.
Write/read anywhere on the medium? [1=Yes/(0=No)]	Do you want to write to the media?
User data will be corrupted. Proceed? [1=Yes/(0=No)] (This question is omitted if you typed 0 to answer the previous question.)	Do you really want to overwrite existing data on the media?
Test time in minutes? [(10)-100]	Your response determines the length of the test, in minutes.
Number of sectors to transfer at a time? [0 - 50]	Your response determines the length of each I/O issued. If you type 0, this is a seek-only test.
Compare after each transfer? [1=Yes/(0=No)] (This question is omitted if you typed 0 to answer the previous question.)	Your response determines whether the processor "manually" compares the results of the read with the expected data (if writing is enabled) or the hardware does the compares after each read.
Test the DBN area? [2=DBN only/(1=DBN and LBN)/0=LBN only]:	Your response determines how to include the DBN area in the test. If you type 2, the test always includes writes, even if you answered the first question with 0.

DRVEXR Modes

DRVEXR can be run in one of the following modes, depending on your responses to the dialogue questions:

Mode	Function
Read/Write	Writes and reads as many blocks as possible in the given amount of time.
Data Integrity	Similar to Read/Write mode, but with a "manual" check of data buffers done by the ISE processor.
Seek Intensive	Only seeks are performed in this mode.
Max Stress	Reads the inner DBNs and outer DBNs alternately.

Mode/Dialogue Relationship

The following table shows the relationship between the four test modes and the responses to the six questions in the dialogue.

Modes	Response to Question					
	1	2	3	4	5	6
Read/Write	1	1	Any	Any	0	Any
Data Integrity	1	1	Any	Any	1	Any
Seek Intensive	0	NA	Any	0	NA	0 or 1
Max Stress	0	NA	Any	0	NA	2

Example

The following is an example of what is displayed when you run DRVEXR.

```
Copyright © 1989 Digital Equipment Corporation
Write/read anywhere on the medium? [1=Yes/(0=No)] 1
User data will be corrupted. Proceed? [1=Yes/(0=No)] 1
Test time in minutes? [(10)-100] 10
Number of sectors to transfer at a time? [0 - 50] 18
Compare after each transfer? [1=Yes/(0=No)]: 0
Test the DBN area? [2=DBN only/(1=DBN and LBN)/0=LBN only]:
    73990 blocks (512 bytes) read.
    73990 blocks (512 bytes) written.
    18666 DBN blocks (512 bytes) read.
    18666 DBN blocks (512 bytes) written.
Complete.
```

DRVTST

Description DRVTST provides a comprehensive test of the ISE hardware. Errors detected by this program can be isolated to the FRU level.

Dialogue The following table describes the DRVTST dialogue.

Message	Explanation
Copyright © 1989 Digital Equipment Corporation	No response is expected.
Write/read anywhere on the medium? [1=Yes/(0=No)]	Do you want to write to the media? If you type 0, this is a read-only test. DRVTST does, however, write to a diagnostic area on the disk.
User data will be corrupted. Proceed? [1=Yes/(0=No)]	Do you really want to overwrite existing data on the media? If you type 0, this is a read-only test.
5 minutes to complete.	No response is expected.
Test passed.	The test was successful. Choose another local program or return control to the system.

Error Messages

The following table describes DRVTST error messages.

Message	Description
Unit is currently in use.	This can mean that the ISE unit is inoperative, in use by a host, or is currently running another local program.
Operation aborted by user.	This message appears if the user stops the program while it is in progress.
Soft read error on head xx track yyyy.	These are soft error messages which indicate that an operation succeeded, but that the error recovery firmware was invoked. These messages may indicate a forced-error flag or correctable ECC error, or that the read/write head was temporarily off-track. These are corrected during normal operation.
Soft write error on head xx track yyyy.	
Soft compare error on head xx track yyyy.	
xxxx - Unit diagnostics failed.	This is a fatal error message where xxxx is the MSCP error code. Call Digital Customer Services.
xxxx - Unit read/write test failed.	This is also a fatal error message where xxxx is the MSCP error code. Call Digital Customer Services.

DRVTST Examples

The following is an example of what is displayed when DRVTST runs successfully.

```
Copyright © 1989 Digital Equipment Corporation
Write/read anywhere on the medium? [1=Yes/(0=No)] 1
User data will be corrupted. Proceed? [1=Yes/(0=No)] 1
  5 minutes to complete.
Test passed.
```

The following is an example of what is displayed when DRVTST has failed.

```
Copyright © 1989 Digital Equipment Corporation
Write/read anywhere on medium? [1=Yes/(0=No)]
0106 - Unit read/write test failed.
```

HISTORY

Description

HISTORY displays ISE information that is used by programs running in the host (such as MDM). The information is displayed in the following order:

- Copyright notice
- Product name
- Serial number
- Node name
- Allocation class
- Firmware revision level
- Hardware revision level
- Power-on hours
- Power cycles
- Last bug check codes (up to 11)

Example

The following is an example of what is displayed when you run the HISTORY program.

```
Copyright © 1989 Digital Equipment Corporation
RF31
EN92300124
R1EJAA
0
RFX X201
RF31 PCB-3/ECO-00
1
45
Complete.
```

ERASE

Description

ERASE is a utility that overwrites data on each ISE. Every writeable LBN and RBN block on the ISE is written several times with a complementary data pattern, and finally is overwritten with zeros.

LBN and RBN

ERASE writes every block in the LBN and RBN space twice the specified number of times: once with the pattern 99(X), and once with the complement pattern 66(X). These two values were selected because they are bit complements of each other in both decoded and encoded formats. That is, the bits toggle in controller memory and the fixed frequency pulse trains on the disk are 180 degrees out of phase with one another, assuming the pulse trains start together.

ERASE Process

Stage	Description
1	After the specified number of write/write-complement operations have been performed, a final pattern of all zeros is written on each block.
2	A failure to write these patterns or to read back all zeros means that the block is “bad” and was previously replaced.
3	The failure and the status of each such block is displayed.
4	If the block is marked bad in the FCT, the user may inhibit this output.
5	The following is repeated to the second block of each RCT copy: <ul style="list-style-type: none">• write/write complement• write of zeros• read back of zeros
6	The second block of the RCT is: <ul style="list-style-type: none">• used as an intermediate holding area for data during bad block replacement• treated as an extension of the user data area by ERASE

Accessing ERASE

You access ERASE the same way you access other local programs. Once a connection is established, the user is prompted to answer a series of questions.

Stopping ERASE

To stop an ERASE in progress, press Ctrl/C, Ctrl/Y, or Ctrl/Z.

Dialogue

The following table explains the ERASE dialogue.

Message	Explanation
Copyright © 1989 Digital Equipment Corporation	No response is expected.
Write/read anywhere on medium? [1=Yes/(0=No)]	Do you want to write to the media?
User data will be corrupted. Proceed? [1=Yes/(0=No)]	Do you really want to overwrite existing data on the media?
How many times should the disk be pre-written before erasing? [0-99]	Specify the number of passes ERASE should make on each sector. A pass is a write with a pattern followed by a write with the pattern complement. A message is displayed indicating your choice.
Display errors erasing known bad blocks? [(1=Yes)/0=No]:	Do you want a list of all ERASE errors in the RCT and the FCT? A message is displayed indicating your choice.
Is this information correct? [(1=Yes)/0=No]:	If you type 0, you are asked the following question.
Do you wish to continue? [1=Yes/(0=No)]:	If you type 1, you are once again prompted to specify the number of passes, and so on. If you type 0, the session ends.
n minutes to complete.	This lists the number of minutes (n) until completion of the erase operation. This number is a function of the number of passes you specified and the ISE type. No response is expected.
Erase complete.	This message indicates that the erase operation is complete. The program stops automatically.

Example

The following is an example of the ERASE utility. The blocks that are listed did not write or did not contain an all-zeros pattern when ERASE read back each track on the LBN/RBN space. In most cases, the failing blocks are listed as "bad" in the FCT.

```
Copyright © 1989 Digital Equipment Corporation
Write/read anywhere on medium? [1=Yes/(0=No)] 1
User data will be corrupted. Proceed? [1=Yes/(0=No)] 1
How many times should the disk pre-written before erasing? [1-99]:
Display errors erasing known bad blocks? [(1=Yes)/0=No]:
The disk will be pre-written 3 times.
All errors will be reported, including FCT bad blocks.
Is this information correct? [(1=Yes)/0=No]:

58 minutes to complete.

          ERASE BAD BLOCK LIST

LBN  Head Track Sector Block Status
-----
14602 4   132   19  Unable to write sector (marked bad in FCT)
14603 4   132   20  Unable to read sector (marked bad in FCT)
14604 4   132   21  Unable to write sector (marked bad in FCT)
14605 4   132   22  Unable to write sector (not found in FCT)
629079 5  1661   12  Non-zero data in sector (marked bad in FCT)
629080 5  1661   13  Unable to write sector (marked bad in FCT)

Erase complete.
```

VERIFY

Description

VERIFY is a utility that is used to determine the amount of “margin” remaining in on-disk structures (for instance, the number of bad blocks in the RCT and thus the number of RBNs consumed). VERIFY is useful when you verify an installation.

The VERIFY utility is read only. It does not overwrite user data and does not perform bad block replacement.

Accessing VERIFY

You access VERIFY the same way you access other local programs. Once a connection is established, you are prompted to answer a series of questions.

Dialogue

The following table describes the VERIFY dialogue.

Message	Explanation
Copyright © 1989 Digital Equipment Corporation	No response is expected.
Print informational (non-warning) messages? [1=Yes/(0=No)]	Your response controls the amount of output produced by VERIFY. Type 1 if you want informational messages displayed.
Report transient error by block? [1=Yes/(0=No)]	Again, your response controls the amount of output produced by VERIFY. By default, a transient, correctable error in a block is not displayed as blocks are read. Type 1 if you want transient errors reported.

Example

The following is an example of VERIFY run on an RF31 ISE. The example is interrupted several times by text that describes the next part of the example.

The first part of this example contains the VERIFY dialogue and the FCT header dump. The FCT header dump provides basic information, such as the serial number and the date of last format (typically the date the HDA was manufactured).

```
Copyright © 1989 Digital Equipment Corporation
Print informational (non-warning) messages? [1=Yes/(0=No)] 1
Report transient error by block? [1=Yes/(0=No)] 1
```

```
***   FCT Block 0 Information   ***

Serial Number:      0000123400000000
Mode:               ADDE(X)
First Formatted:   22-MAY-1989 11:58:26
Date Formatted:    22-MAY-1989 11:58:26
Format Instance:    1
FCT:               VALID
Bad PBNs in FCT:    34

Scratch Area Offset: 30032
Size (Not Last):    2480
Size (Last):        2480

Flags:              0000(X)
Format Version:     1
```

The next part of the example contains the RCT header dump followed by a read check of the RCT. Note that one sector of one copy of the RCT (the fifth copy, block 68) is not usable.

```
***   RCT Block 0 Information   ***
Serial Number:      0000123400000000
Flags:              0000(X)
LBN Being Replaced: 0
Replacement RBN:    0
Bad RBN:            0
*****   Revector Control Table for R1VJAA$DIA3   *****
Copy 5 of RCT block 68 (LBN 745103.) is bad.
```

After the read check of the RCT, each bad block in the RCT is displayed. In this abbreviated syntax, the symbol *-> means that a bad LBN is replaced by an RBN not on its track. The symbol -> means that the bad LBN is replaced by its primary (on-track) RBN.

```

    2 -->      0,  2083 -->    41,  3569 -->    71,
  9566 *->   190,  9564 -->   191,  9563 *->   192,
14603 -->   292, 15361 -->   307, 15398 *->   308,
18762 -->   375, 19403 -->   388, 21198 -->   423,
22695 -->   453, 22788 *->   454, 22791 -->   455,
22790 *->   457, 22789 *->   458, 23183 *->   462,
23182 *->   464, 28081 -->   561, 31026 *->   619,
31027 *->   621, 33589 -->   671, 35495 -->   709,
45046 -->   900, 45339 -->   906, 48484 -->   969,
57875 -->  1157, 63818 -->  1276, 70125 -->  1402,
:           :           :           :           :
(many lines have been deleted from this example)
:           :           :           :           :
Bad RBN:   12041, 602527 --> 12050, Bad RBN:   12073,
609475 --> 12189, Bad RBN:   12217, 613875 --> 12277,
645331 --> 12906, 645330 *-> 12907, 645885 --> 12917,
652795 --> 13055, 656745 --> 13134, 657589 --> 13151,
664108 --> 13282, 675509 --> 13510, 679607 --> 13592,
693585 --> 13871, 694130 --> 13882, 694129 *-> 13883,
707101 --> 14142, 707100 *-> 14143, 711501 --> 14230,
711607 --> 14232, 717484 --> 14349, 721878 --> 14437,
722237 --> 14444, 723439 --> 14468, 729597 --> 14591,
732140 --> 14642, 732372 --> 14647, 735723 --> 14714,
737467 --> 14749, 739349 --> 14786, 742125 --> 14842,

```

The next part of this example summarizes the contents and state of the RCT.

```

RCT Statistics:
    47 Bad RBNs
   185 Bad LBNs
   140 Primary Revectorors
    45 Non-Primary Revectorors
     1 Bad RCT Blocks
     0 Bad First Copy RCT Blocks

```

A similar scan of the FCT follows. Each bad block in the FCT is displayed. Entries in this display are physical blocks. The syntax DKUTIL uses for PBNs is also used here. It is h:t:s:, where h is the head number, t is the track number, and s is the sector number. If the bad block is used by the disk format, the corresponding block number is displayed in parentheses.

```

*****   Factory Control Table for R1VJAA$DIA3   *****
1: 96:50(LBN 2083) 1: 161:48(LBN 28081) 1: 181: 0(LBN 36084)
1: 212: 0(LBN 48484) 2: 259: 8(LBN 70125) 1: 374: 0(LBN 113284)
3: 452:23(LBN 142973) 1: 558: 0(LBN 186884) 5: 564:17(LBN 188684)
5: 565:17(LBN 189084) 3: 630:38(LBN 214188) 3: 634:16(LBN 215766)
2: 673:43(LBN 235709) 6: 822: 0(LBN 293100) 3: 938:25(LBN 337375)
1:1009:40(LBN 367273) 5:1160:30(LBN 427097) 7:1208: 1(LBN 447185)
5:1321: 8(LBN 491475) 3:1440: 8(LBN 538158) 3:1442: 8(LBN 538958)
5:1449: 8(LBN 542675) 3:1454: 8(LBN 543758) 3:1459: 8(LBN 545758)
6:1471:40(LBN 552740) 5:1532: 8(LBN 575875) 5:1546: 8(LBN 581475)
5:1559: 8(LBN 586675) 0:1556:20(LBN 587620) 5:1616: 8(LBN 609475)
5:1627: 8(LBN 613875) 6:1731:45(LBN 656745) 6:1778: 9(LBN 675509)
0:1786: 7(LBN 679607)

```

The state of the FCT is displayed next.

```

FCT Statistics:
                0 Bad FCT Blocks
                0 Bad First Copy FCT Blocks

```

In the last part of this example, the LBN area is scanned. Each LBN block is read, some LBN statistics are displayed, and VERIFY ends. In this example, transient error reporting was enabled so the transients are displayed.

```

*****   Scan of LBN Area   *****
LBN 2740. has a transient (5 out of 6) error.
LBN 7904. has a transient (3 out of 6) error.
LBN 77100. has a transient (4 out of 6) error.
LBN 95831. has a transient (1 out of 6) error.
LBN 577712. has a transient (1 out of 6) error.
LBN 730484. has a transient (1 out of 6) error.

LBN Statistics:      6 Block(s) with a Transient error.
                   6 Total Block(s) in error.

Complete.

```

Error Messages

The following table describes the VERIFY error messages.

Message	Description
00C5 - Unit diagnostics failed.	The ISE unit diagnostics failed and VERIFY cannot run.
xxxx - Multicopy read operation of xCT block n failed.	Block n of a multicopy structure, the FCT, or the RCT, is not readable. xxxx is the MSCP error code.
Copy n of RCT block m (LBN x) is bad.	Copy n of RCT block m, corresponding to LBN block x, is bad.
xBN n has a forced error.	While scanning the LBN, DBN, or XBN space, block n was marked with a forced error flag.
xBN n has an invalid header error.	While scanning the LBN, DBN, or XBN space, block n had a problem with its header.
xBN n has a data sync timeout error.	While scanning the LBN, DBN, or XBN space, block n had problems syncing up to the data bits.
xBN n has an ECC field correctable error.	While scanning the LBN, DBN, or XBN space, block n suffered an error, but only in the ECC field.
xBN n has an uncorrectable ECC error.	While scanning the LBN, DBN, or XBN space, block n was unreadable due to an uncorrectable ECC error.
xBN n received error status : xxxx(X).	While scanning the LBN, DBN, or XBN space, block n has some other error. The MSCP error code is xxxx.

Warning Messages

The following table describes the VERIFY warning messages.

Message	Description
xCT block n used copy m.	The first copy of block n of a multicopy structure, the FCT, or the RCT, is not readable. Copy m of that block was used instead.
xBN n has a transient (e out of six) error.	While scanning the LBN, DBN, or XBN space, block n suffered a transient error. Out of six reads, the transient error happened e times.
xBN n has a k symbol correctable ECC error.	While scanning the LBN, DBN, or XBN space, block n suffered a correctable ECC error of k bytes.
Table is empty (NO BAD PBNs).	This message is very rare, and indicates that no blocks are marked bad in the FCT. The media was perfect when the ISE unit was formatted.

DKUTIL

Description

DKUTIL is a utility that displays disk structures and disk data. The utility can be used to verify that an ERASE worked correctly. DKUTIL is also useful in problem diagnosis and manual bad block replacement.

Accessing DKUTIL

You access DKUTIL the same way you access other local programs. Once a connection is established, all interaction occurs through the use of commands and responses. DKUTIL has its own command line interpreter. It has a command syntax similar to the hierarchical storage controller (HSC) DKUTIL utility.

DKUTIL Process

- DKUTIL prompts the user for a command with the DKUTIL> prompt.
- In most cases, the user issues a GET command to acquire an ISE unit from the MSCP server. (See GET later in this chapter.) Subsequent commands are applied to this unit.
- DKUTIL acquires the unit and then returns to the command mode, prompting for a command, executing it, and prompting for another command.

Stopping DKUTIL

To stop DKUTIL, press `Ctrl/C`, `Ctrl/Y`, `Ctrl/Z`, or type EXIT at the DKUTIL> prompt.

DKUTIL Commands

The following table lists the available DKUTIL commands. You do not need to type the entire command because the program is set up to recognize the matching command from the abbreviated command. The abbreviated command is shown in uppercase bold letters.

Command	Definition
DE fault	Changes the default modifiers for subsequent DKUTIL commands.
DI splay	Displays characteristics, error history, and RCT /FCT information.
DU mp	Dumps the contents of a sector on the disk or the contents of the current buffer.
Exit	Stops the DKUTIL utility.
Get	Acquires the ISE unit from the MSCP server.
Help	Displays information on how to use the DKUTIL commands.
PO p	Restores the save buffer to the current buffer.
PU sh	Stores the current buffer in the save buffer.
RE place	Replaces a specified LBN.
Set size	Changes the block size of the ISE unit.

DKUTIL Command Modifiers

A number of modifiers are used with the DKUTIL GET, DISPLAY, and DUMP commands. These modifiers can be typed with the command or they can be stored using the DEFAULT command. The following tables describe the modifiers and their functions.

GET Modifier	Default Setting	Function
IMF	/NOIMF	Ignore media format. If this modifier is specified, the unit is acquired for physical (PBN) access only.
WP	/WP	Write protect. If this modifier is specified, the media is write protected. This inhibits replacements.

DISPLAY Modifier	Default Setting	Function
FULL	/NOFULL	Display full. If this modifier is specified, a full dump of the RCT or FCT header is displayed.
ITEMS	/NOITEMS	Display items. If this modifier is specified, the items in the RCT or FCT are displayed.

DUMP Modifier	Default Setting	Function
HEADER	/HEADER	Display header. If this modifier is specified, the block type and LTNO fields of the block are displayed.
EDC	/EDC	Display the EDC. If this modifier is specified, the EDC and the expected EDC of the block are displayed.
DATA	/DATA	Display data. If this modifier is specified, the data in the block is displayed.
ECC	/NOECC	Display ECC. If this modifier is specified, the ECC residue of the block is displayed.
ALL	/NOALL	Display all fields. Use of this modifier is equivalent to specifying the modifiers /HEADER/EDC/DATA/ECC.
RAW	/NORAW	Display the raw LBN. If this modifier is specified, the original LBN that was replaced is used instead of the RBN. This modifier affects only the replaced LBNs.
NZ	/NONZ	Display nonzero data. If this modifier is specified, the data field is displayed if it contains all nonzero data. This modifier has no effect if /NODATA is also specified.

DEFAULT

The DEFAULT command changes the default modifiers for subsequent DKUTIL commands. This command “remembers” modifiers so they do not have to be typed each time a command is issued. Modifiers that do not apply to a command are ignored when that command is issued. So, you can specify modifiers that apply to GET, DUMP, and DISPLAY at the same time.

DEFAULT Syntax

The syntax for the DEFAULT command is:

```
DEFAULT [modifiers]
```

The available *modifiers* are described in the tables on the preceding two pages.

DEFAULT Example

The following example shows how to access the DKUTIL program on an ISE with the unit name R1EJAA.

Once DKUTIL is accessed, the DEFAULT command is issued to set new default values for subsequent commands. GET will apply /NOWP; DUMP will apply /NZ; and DISPLAY will apply /FULL and /ITEMS.

Note that both the DEFAULT command and the /ITEMS modifier are abbreviated.

```
$ SET HOST/DUP/SERVER=MSCP$DUP/TASK=DKUTIL R1EJAA
%HSCPAD-I-LOCPRGEXE, Local program executing
Copyright © 1989 Digital Equipment Corporation
DKUTIL> DE/NOWP/NZ/FULL/ITE
```

DISPLAY

The **DISPLAY** command displays characteristics, error history, and RCT/FCT information.

DISPLAY Syntax

There are three basic variations to the **DISPLAY** command:

- **DISPLAY CHARACTERISTICS DISK**
This displays the characteristics of the ISE unit.
- **DISPLAY [/FULL][/ITEMS] {RCT,FCT}**
This displays the header of the RCT or the FCT. The **/FULL** modifier controls the amount of RCT or FCT header information displayed. If the **/ITEMS** modifier is specified, the contents of the RCT or FCT are also displayed.
- **DISPLAY ALL**
This is equivalent to typing **DISPLAY RCT**, **DISPLAY FCT**, and **DISPLAY CHARACTERISTICS DISK**.

DISPLAY Modifiers

The following table describes the modifiers used with the **DISPLAY** command.

Modifier	Default	Function
FULL	/NOFULL	Display full. If this modifier is specified, a full dump of the RCT or FCT header is displayed.
ITEMS	/NOITEMS	Display items. If this modifier is specified, the items in the RCT or FCT are displayed.

DISPLAY Example

The following example shows how the DISPLAY command lists the ISE unit characteristics.

```
DKUTIL> DISP CHA DIS
      Drive characteristics for drive R1EJAA$DIA1
Type:      RF31 (512 byte mode only)
Media:     Fixed
Cylinders: 1861 LBN, 5 XBN, 5 DBN
Geometry:  1 tracks/group, 8 groups/cylinder,
           8 tracks/cylinder, 50 LBNS/track,
           1 RBNS/track, 51 sectors/track,
           51 XBNs/track, 408 XBNs/cylinder,
           400 LBNS/cylinder, 8 RBNS/cylinder
Group Offset: 17 (LBN), 0 (XBN)
LBNS:      744400 (host), 745416 (total)
RBNS:      14888
XBNS:      2040
DBNS:      1632 (read/write), 408 (read only)
PBNS:      838032
RCT:       127 (size), 8 (copies)
FCT:       127 (size), 8 (copies)
Retry Limits: 8 (retry), 3 (badblk)
ECC Threshold:3/2 (normal), 0/0 (format)
Revision:   4 (hardware), 32 (firmware)
Drive ID:   124923040310000
```

DUMP

The DUMP command displays the contents of a sector on the disk or the contents of the current buffer. The amount of information displayed can be controlled with modifiers.

DUMP Syntax

There are five basic variations of the DUMP command:

- **DUMP BUFFER**
This dumps the contents of the current buffer.
- **DUMP {DBN,LBN,RBN,XBN} *block#***
This dumps the contents of the specified *block#*. The LBN space extends into the RCT, and the XBN space spans all copies of the FCT. These methods of reading the RCT and FCT allow a specific copy to be read.
- **DUMP {RCT,FCT} *block#***
This dumps the contents of the specified *block#*. The block is read using the multiread algorithm. This command also shows you which copy was used to obtain the information.
- **DUMP PBN *head#.track#.sector#***
This dumps the contents of the specified block by giving the physical location of the sector not adjusted by LTN0. This variation of the DUMP command is not supported on the RF36 or RF74.
- **DUMP PBD *head#.track#.sector#***
This dumps the contents of the specified block. This variation of the DUMP command is supported only on the RF36 and RF74.

DUMP Modifiers

The following describes modifiers used with DUMP.

Modifier	Default	Function
HEADER	/HEADER	Display header. If this modifier is specified, the block type and LTNO fields of the block are displayed.
EDC	/EDC	Display the EDC. If this modifier is specified, the EDC and the expected EDC of the block are displayed.
DATA	/DATA	Display data. If this modifier is specified, the data in the block is displayed.
ECC	/NOECC	Display ECC. If this modifier is specified, the ECC residue of the block is displayed.
ALL	/NOALL	Display all fields. Use of this modifier is equivalent to specifying the modifiers /HEADER/EDC/DATA/ECC.
RAW	/NORAW	Display the raw LBN. If this modifier is specified, the original LBN that was replaced is used instead of the RBN. This modifier affects only the replaced LBNs.
NZ	/NONZ	Display nonzero data. If this modifier is specified, the data field is displayed if it contains all nonzero data. This modifier has no effect if /NODATA is also specified.

DUMP Example

The following example shows how the DUMP command displays the contents of a block of the RCT.

Note that the first copy of this RCT block was used. Also note that LBN 0 is replaced by RBN 0.

```
DKUTIL> DUMP RCT 2
*** Buffer for RCT block 2 (LBN 744402 used), MSCP Status: 0000
    LTN 0 = 90          Type = 47 (X)
    EDC = 032F(X)      Calculated EDC Difference = 14B3(X)
Data = 3000 0000 0000 0000 0000 0000 0000 0000
+ 16  0000 0000 0000 0000 0000 0000 0000 0000
+ 32  0000 0000 0000 0000 0000 0000 0000 0000
+ 48  0000 0000 0000 0000 0000 0000 0000 0000
+ 64  0000 0000 0000 0000 0000 0000 0000 0000
+ 80  0000 0000 0000 0000 0000 0000 0000 0000
+ 96  0000 0000 0000 0000 0000 0000 0000 0000
+112  0000 0000 0000 0000 0000 0000 0000 0000
+128  0000 0000 0000 0000 0000 0000 0000 0000
+144  0000 0000 0000 0000 0000 0000 0000 0000
+160  0000 0000 0000 0000 0000 0000 0000 0000
+176  0000 0000 0000 0000 0000 0000 0000 0000
+192  0000 0000 0000 0000 0000 0000 0000 0000
+208  0000 0000 0000 0000 0000 0000 0000 0000
+224  0000 0000 0000 0000 0000 0000 0000 0000
+240  0000 0000 0000 0000 0000 0000 0000 0000
+256  0000 0000 0000 0000 0000 0000 0000 0000
+272  0000 0000 0000 0000 0000 0000 0000 0000
+288  0000 0000 0000 0000 0000 0000 0000 0000
+304  0000 0000 0000 0000 0000 0000 0000 0000
+320  0000 0000 0000 0000 0000 0000 0000 0000
+336  0000 0000 0000 0000 0000 0000 0000 0000
+352  0000 0000 0000 0000 0000 0000 0000 0000
+368  0000 0000 0000 0000 0000 0000 0000 0000
+384  0000 0000 0000 0000 0000 0000 0000 0000
+400  0000 0000 0000 0000 0000 0000 0000 0000
+416  0000 0000 0000 0000 0000 0000 0000 0000
+432  0000 0000 0000 0000 0000 0000 0000 0000
+448  0000 0000 0000 0000 0000 0000 0000 0000
+464  0000 0000 0000 0000 0000 0000 0000 0000
+480  0000 0000 0000 0000 0000 0000 0000 0000
+496  0000 0000 0000 0000 0000 0000 0000 0000
```

EXIT The EXIT command stops the DKUTIL utility. If the ISE unit was acquired, the unit is released to the MSCP server.

EXIT Syntax The syntax for this command is:
EXIT

EXIT Example The following is an example of what appears on the screen when you EXIT DKUTIL.

```
DKUTIL> EXIT
%HSCPAD-S-REMPGMEND, Remote program terminated - message code 3.
%HSCPAD-S-END, Control returned to node ISMINE
```

GET The GET command acquires the ISE unit from the MSCP server (if possible). Most DKUTIL commands work only after the GET command succeeds. The GET command cannot succeed if the ISE unit is on line to any host.

GET Syntax The syntax for the GET command is:

GET [*modifier*]

The specified *modifier* controls how the unit is acquired.

GET Modifiers The following table describes the modifiers used with the GET command.

Modifier	Default	Function
IMF	/NOIMF	Ignore media format. If this modifier is specified, the unit is acquired for physical (PBN) access only.
WP	/WP	Write protect. If this modifier is specified, the media is write protected. This inhibits replacements.

GET Example The following example shows the outcome of a successful GET command. The unit is acquired from the MSCP server and the unit FCT status is displayed. In this example, /NOWP was previously set by the DEFAULT command and /NOIMF was the default upon entry to DKUTIL.

```
DKUTIL> GET
Serial Number:      0000000000000000
Mode:               ADDE(X)
First Formatted:    9-AUG-1989 13:25:10
Date Formatted:     9-AUG-1989 13:25:10
Format Instance:    1
FCT:                VALID
```

HELP The HELP command displays information on how to use the DKUTIL commands.

HELP Syntax The syntax for the HELP command is:
HELP

HELP Example Typing HELP produces the following display.

```
DKUTIL> HELP
  DEFAULT [/qualifiers]
  DISPLAY [/qualifiers] {ALL|FCT|RCT|CHAR DISK}
    /FULL        /ITEMS
  DUMP [/qualifiers] {BUFFER|type n|PBN h:t:s}
    /HEADER     /EDC        /DATA
    /NZ         /ECC        /ALL
    /RAW
  EXIT
  GET [/qualifiers]
    /IMF        /WP
  HELP
  POP
  PUSH
  REPLACE lbn
  SET SIZE 512
DKUTIL>
```

POP

The POP command restores the save buffer to the current buffer.

DKUTIL maintains two I/O buffers while it runs: the current buffer and the save buffer. The DUMP command always uses the current buffer. Use the PUSH command to save data before subsequent DUMPs. Use the POP command, followed by the DUMP BUFFER command, to view the saved data.

POP Syntax

The syntax for this command is:

```
POP
```

POP Example

In this example, the contents of the buffer saved by the most recent PUSH command is restored to the current buffer.

```
DKUTIL> POP
```

PUSH

The PUSH command stores the current buffer in the save buffer.

DKUTIL maintains two I/O buffers while it runs: the current buffer and the save buffer. The DUMP command always uses the current buffer. Use the PUSH command to save data before subsequent DUMPs. Use the POP command, followed by the DUMP BUFFER command, to view the saved data.

PUSH Syntax

The syntax for this command is:

```
PUSH
```

PUSH Example

In this example, the contents of the buffer loaded by the most recent DUMP command are stored in the save buffer.

```
DKUTIL> PUSH
```

REPLACE

The REPLACE command replaces a specified LBN. The results of the REPLACE command are displayed. The display contains the last few longwords of a Bad Block Replacement Summary error log packet.

REPLACE cannot succeed if the unit is write protected (GET /WP), or if the unit was acquired for physical (PBN) access only (GET/IMF).

REPLACE Syntax

The syntax for the REPLACE command is:

```
REPLACE lbn#
```

The specified *lbn#* is replaced.

REPLACE Example

In the following example, LBN0 is replaced.

```
DKUTIL> REPLACE 0
Replace summary log packet:
  Flags: 60(X)
  Event: 0014(X)
Rep flags: 8000(X)
  LBN: 0
  Old RBN: 0
  New RBN: 0
```

SET SIZE

The **SET SIZE** command changes the block size of the ISE unit. Only 512-byte block sizes are supported. This command is for compatibility with the HSC implementation of DKUTIL.

**SET SIZE
Syntax**

The syntax for the **SET SIZE** command is:

```
SET SIZE blocksize#
```

Currently, the only acceptable *blocksize#* is 512.

**SET SIZE
Example**

This example shows the block size of the unit set to 512 bytes.

```
DKUTIL> S S 512
```

PARAMS

Description

PARAMS is a utility that allows you to examine and change internal ISE parameters such as node name, allocation class, and MSCP unit number. PARAMS is also used to display the state of the ISE and performance statistics maintained by the ISE.

Accessing PARAMS

You access PARAMS the same way you access other local programs. Once a connection is established, all interaction occurs through the use of commands and responses. PARAMS has its own command line interpreter. It has a command syntax similar to the VMS SYSGEN utility.

PARAMS Process

- PARAMS prompts the user for a command with the PARAMS> prompt.
- Once a command is entered, PARAMS executes it and then prompts for another command.

Stopping PARAMS

To stop PARAMS, press `Ctrl/C`, `Ctrl/Y`, `Ctrl/Z`, or type EXIT at the PARAMS> prompt.

PARAMS Commands

The following table lists the available PARAMS commands. You do not need to type the entire command because the program is set up to recognize the matching command from the abbreviated command. The abbreviated command is shown in uppercase bold letters.

Command	Definition
ENable mscp	Enables MSCP server.
Exit	Stops the PARAMS utility.
Help	Displays information on how to use PARAMS commands.
Locate	Causes a soft fault in the ISE. (Red LED on to help locate it.)
SEt	Changes internal ISE parameters.
SHow	Displays the setting of a parameter or a class of parameters.
STatus	Displays module configuration, history, performance counters, and so on.
Write	Records the device parameter changes you make using the SET command in nonvolatile RAM.
Zero	Clears a block of counters or all known blocks of counters.

EXIT

The EXIT command stops the PARAMS utility.

EXIT Syntax

The syntax for the EXIT command is:

```
EXIT
```

EXIT Example

The following is an example of what appears on the screen when you EXIT PARAMS.

```
PARAMS> EXIT  
Exiting ...  
  
%HSCPAD-S-REMPGMEND, Remote program terminated  
%HSCPAD-S-END, Control returned to node ISMINE
```

HELP

The HELP command displays information on how to use PARAMS commands. It is not a substitute for this document, but is useful as a quick reference.

HELP Syntax

The syntax for the HELP command is:

HELP

HELP Example

The following is what appears on the screen when you type HELP.

```
PARAMS> help
ENABLE MSCP
EXIT
HELP
LOCATE
SET {parameter | .} value
SHOW {parameter | . | /class}
  /ALL      /CONST  /DRIVE
  /SERVO    /SCS    /MSCP
  /DUP
STATUS [type]
CONFIG LOGS   DATALINK
PATHS  SYSTEM SEEKS
MSCP   THREADS
WRITE
ZERO counter
  ALL      MSCP   SEEKS
PARAMS>
```

LOCATE

The LOCATE command causes a soft fault in the ISE to help you locate it. The soft fault does not affect its current operation or state. The Fault LED on the drive module and the Fault LED on the operator control panel turn on and stay on until you press at the PARAMS> prompt.

LOCATE Syntax

The syntax for the LOCATE command is:

```
LOCATE
```

LOCATE Example

The following is what appears on the screen when you type LOCATE.

```
PARAMS> LOCATE
Drive has been soft faulted to help locate it
Press RETURN to continue:
PARAMS>
```

SET

The SET command changes internal ISE parameters. The changes are made to a working copy of the ISE parameters and do not take effect until a WRITE command is successful.

SET Syntax

The syntax for the SET command is:

```
SET parameter value
```

The *parameter* is the name of the parameter to be set, or the special symbol . (period), which means the last SET or SHOWn parameter. The *value* is the new value you want to assign to the parameter.

The available parameters are listed on the following page. If the parameter name is abbreviated, the first matching parameter is used without regard to uniqueness. We recommend that you use SHOW before you use SET.

SET Example

The following example changes the node name from the default (R1EJAA) to the new string "SUSAN". When entering ASCII strings, you may use single quotes, double quotes, or no quotes at all.

```
PARAMS> SHOW NODE
Parameter      Current      Default      Type      Radix
-----
NODENAME       R1EJAA       RF31         String    Ascii    B

PARAMS> SET . "SUSAN"
PARAMS> SHOW .
Parameter      Current      Default      Type      Radix
-----
NODENAME       SUSAN        RF31         String    Ascii    B

PARAMS>
```

SET and SHOW Parameters

The following tables describe the SET and SHOW command parameters and their functions.

MSCP Parameter	Function
ALLCLASS	Sets or shows the allocation class of the disk MSCP server.
UNITNUM	Sets or shows the MSCP unit number.
FORCEUNI	Determines whether the parameter UNITNUM or the DSSI node ID is used as the MSCP unit number. The factory setting for this parameter is 1 (true), and the DSSI node ID is used. Until set to 0 (false), the UNITNUM parameter is ignored.
HISPEED ¹	The factory setting for this parameter is 0 (false). If set to 1 (true), only half of the ISE capacity is presented to hosts. This reduces the stroke of the seek, and thus improves performance at the expense of capacity. Average seek time is reduced by approximately 3 ms.
SEEKALG	Selects one of three seek algorithms. The factory setting is the C-scan algorithm (2). You can also select the shortest distance algorithm (0), or the elevator algorithm (1).
FIVEDIME	Determines whether the MSCP server supports five concurrent connections (the factory default of 1, true) or seven connections with reduced resources allocated to each (0, false).

¹This option is available only on the RF31.

DRIVE Parameter	Function
VOLSERNO	Shows the volume serial number of the HDA.

DUP Parameter	Function
ADD_CR	Appends a <code>Return</code> character after each message. The factory setting is 0 (false).
ADD_LF	Appends a <code>Line Feed</code> to each message. The factory setting is 0 (false).

SCS Parameter	Function
SYSTEMID	Sets or shows the 48-bit Systems Communication Services (SCS) system ID of the ISE.
NODENAME	Sets or shows the SCS node name of the ISE.
FORCENAM	Determines whether the value set by the NODENAME parameter or the string RFYYx ¹ is returned as the SCS node name. The letter x corresponds to the DSSI node ID (A = 0, B = 1, and so on). The factory setting is 0 (false), and the value set by NODENAME is used.

¹RFYYx is returned as the SCS nodename, where: YY represents the ISE type, either 31, 35, 36, 72, 73, or 74; and x corresponds to the DSSI node ID (A = 0, B = 1, and so on).

SHOW

Displays the setting of a parameter or a class of parameters. The full name of the parameter, its current value, default value, radix and type, and any flags associated with the parameter are displayed.

SHOW Syntax

The syntax for the SHOW command is:

```
SHOW parameter_or_class
```

The *parameter_or_class* is a parameter name, the special symbol `.` (period), which means the last SET or SHOWn parameter, or a SHOW class preceded by a `/` (slash).

If an abbreviation is used, the first matching parameter or class is displayed.

SHOW Classes

The following table describes the available SHOW classes.

Class	Description
/ALL	All SHOW classes are displayed.
/CONST	ISE constants are grouped in this class.
/DRIVE	Drive parameters, typically those governing drive calibrations, thresholds, and retries, are grouped in this class.
/SERVO	Servo parameters, typically the results of drive calibrations, are grouped in this class.
/SCS	SCS parameters are grouped in this class. The node name and system ID are in this class.
/MSCP	MSCP parameters are grouped in this class. The parameters that control the unit number are in this class.
/DUP	DUP parameters are grouped in this class.

SHOW Example

The following example shows various forms of the SHOW command and how they are used to change the MSCP unit number from the default (DSSI bus ID) to a new value of 8402.

```

$ SET HOST/DUP/SERVER=MSCP$DUP/TASK=PARAMS R1EJAA
%HSCPAD-I-LOCPRGEXE, Local program executing
Copyright © 1989 Digital Equipment Corporation

PARAMS> SHOW FORCEUNI
Parameter      Current      Default      Type      Radix
-----
FORCUNI        1              1      Boolean  0/1  U

PARAMS> SET . 0
PARAMS> SHOW UNITN
Parameter      Current      Default      Type      Radix
-----
UNITNUM        0              0      Boolean   Dec  U

PARAMS> SET . 8402
PARAMS> SHOW /MSCP
Parameter      Current      Default      Type      Radix
-----
MSCPNVR        20202020202020 20202020202020
                20202020202020 20202020202020
                20202020202020 20202020202020
                20202020202020 20202020202020
                String      Hex  RO
WRTLOGSZ        2              2      Word     Dec  RO
UNITID          1B02403192300124 00000000000000 Quadword Hex  RO
ALLCLASS        0              0      Byte     Dec  B
MEDIAID         2264601F        2264601F Longword  Hex  RO U
HISPEED         0              0      Boolean  0/1  U
UNITNUM         8402           0      Word     Dec  U
FORCEUNI        0              1      Boolean  0/1  U
FORCEID         1              1      Boolean  0/1  RO
FIVEDIME        1              1      Boolean  0/1  B
SEEKALG         2              2      Byte     Dec
CNT_TMO         60             60      Word     Dec  RO

PARAMS>

```

STATUS

The STATUS command displays a variety of information including module configuration, transient and unit error history, performance counters, and so on. The STATUS type you select determines the type of information displayed.

STATUS Syntax

The syntax for the STATUS command is:

STATUS [*type*]

The *type* is an option that corresponds to a type of information. If omitted, all available types of status information are displayed. If the *type* is abbreviated, all matching types are displayed.

STATUS Types

The following table describes the available STATUS types.

Type	Function
CONFIG	Displays module configuration information and some system information such as power-on hours and the system time.
LOGS	Displays the last 11 transient errors recorded in nonvolatile RAM. In VMS terms, these are the last 11 machine checks and bug checks known to the controller.
DATALINK	Displays the DSSI data link counters. These include the number of packets received and transmitted, the number of NAKs sent and received, and so on.
PATHS	Displays the topology of the DSSI bus on which this ISE resides by displaying open virtual circuits to other nodes on the bus and related packet counters.
SYSTEM	Displays system statistics and counters.
SEEKS	Displays seek statistics such as average seek times and a seek length histogram.
MSCP	Displays MSCP statistics such as the number and type of I/O commands and various histograms.
THREADS	Displays the known programs in the system, the amount of CPU time consumed, and other information.

STATUS Examples

The following examples show the use of three STATUS commands.

```
PARAMS> STAT CONFIG
```

```
Configuration:
```

```
Node R1EJAA is an RF31 controller  
Software RFX V200 built on 22-AUG-1989 13:39:09  
Electronics module name is EN92300124  
In 26 power-on hours, power has cycled 45 times  
System up time is 1 01:25:07.90  
System time is 26-AUG-1989 15:00:12
```

```
PARAMS> STATUS DATALINK
```

```
Datalink Counters:
```

```
Interval: 91593 seconds  
Pkts Rcv'd: 121535:*****  
Pkts Xmt'd: 121536:*****  
Naks Rcv'd: 23665:*****  
Nakd Xmt'd: 0:  
Resets Rcv'd: 45713:*****  
Resets Xmt'd: 21369:*****  
No response: 2290:*  
Duplicates: 0:  
Unrecogs: 0:
```

```
PARAMS> STATUS PATHS
```

ID	Path	Block	Remote Node	DG_S	DG_S	MSG_S	MSG_S
1	PB	FF84517A	Internal Path	0	0	0	0
0	PB	FF8452A6	R3QZTI RFX V103	0	0	0	0
3	PB	FF8453D2	R7ZIAA RFX V103	0	0	0	0
4	PB	FF8454FE	R7ZJBA RFX V103	0	0	0	0
5	PB	FF84562A	R7ULBA RFX V103	0	0	0	0
6	PB	FF845756	LEDS13 VMS V5.2	0	0	27497	27497
7	PB	FF845882	ISMINE VMS V5.2	0	0	32636	32636

```
PARAMS>
```

WRITE

The WRITE command records the device parameter changes you make using the SET command in nonvolatile memory. The WRITE command is similar to the VMS SYSGEN WRITE command, although no parameters are available.

Reasons for Failure

When using the WRITE command, you must be aware of system and/or ISE requirements and use the command accordingly. Otherwise, it may not succeed. The WRITE command may fail for one of the following reasons:

- **Unit not Acquired**

You altered a parameter that required the unit, and the unit could not be acquired (it was not in the available state with respect to all hosts). Changing the unit number is an example of a parameter that requires the unit.

A parameter requires the unit if the flag U appears at the right of the SHOW display (refer to the SHOW example).

- **Unit not Initialized**

You altered a parameter that required controller initialization, and you replied negatively to the request for reboot. Changing the node name or the allocation class are examples of parameters that require controller initialization.

A parameter requires controller initialization if the flag B appears at the right of the SHOW display (refer to the SHOW example).

- **Calibrations in Progress**

Initial drive calibrations were in progress on the unit. The use of the WRITE command is inhibited while these calibrations are running. In this case, the message "Drive calibration in progress, please try later" is displayed.

WRITE Syntax

The syntax for the WRITE command is:

```
WRITE
```

WRITE Example

The following is an example of how you use the WRITE command to change the allocation class from 0 to 4.

```
PARAMS> SHOW ALL
Parameter      Current      Default      Type      Radix
-----
ALLCLASS              0              0      Byte      Dec B

PARAMS> SET . 4
PARAMS> WRITE
Changes require controller initialization, ok? [Y/(N)] Y
Initializing...
```

Note

It takes about 1 minute before the following message is printed.

```
%HSCPAD-S-REMPGMEND, Remote program terminated - message number 3.
%HSCPAD-S-END, Control returned to node R1EJAA
```

ZERO

The ZERO command clears a block of counters or all known blocks of counters.

ZERO Syntax

The syntax for the ZERO command is:

ZERO *counter*

The *counter* is a block of performance counters or all known counters.

Counter Types

The following table describes the available counter values.

Counter	Function
ALL	Clears all performance counter blocks.
MSCP	Clears the MSCP performance counters and histograms.
SEEKS	Clears the seek performance counters and histograms.

ZERO Example

The following example of the ZERO command clears the MSCP performance counters and histograms.

```
PARAMS> STATUS MSCP
MSCP statistics:
  Interval: 92715 seconds
  I/O Commands: 0
  Max Queue Depth: 0
  Queue Depth Histogram:
  Commands Processed Histogram:
  GetUnit      1546:*****
  SetCon:      2:*
  Blocks Accessed Histogram (cylinder ranges):
  Read Lengths Histogram (block count ranges):
  Write Lengths Histogram (block count ranges):

PARAMS> ZERO MSCP
PARAMS> STATUS MSCP
MSCP statistics:
  Interval: 2 seconds
  I/O Commands: 0
  Max Queue Depth: 0
  Queue Depth Histogram:
  Commands Processed Histogram:
  Blocks Accessed Histogram (cylinder ranges):
  Read Lengths Histogram (block count ranges):
  Write Lengths Histogram (block count ranges):

PARAMS>
```

5

Troubleshooting Procedures

Performing Troubleshooting Procedures

In this Chapter

This chapter covers the following topics:

- What to do if the ISE operates incorrectly
- Failure indications
- Internal self-tests

Introduction

This chapter describes what you should do if your ISE operates incorrectly. Also described in this chapter are failure indications and internal self-tests.

Note

Remember that repairs to the ISE should be attempted only by qualified Digital Customer Services engineers.

Self-Tests

POST

The ISE automatically performs a self-test whenever power is applied. This power-on self-test (POST) is designed to detect most faults that occur in the ISE. More information on POST is found in Chapter 2.

Internal Tests and Calibrations

Periodic internal tests and calibrations are performed as a normal part of the operation of the ISE. These tests are run automatically on a periodic basis and cause the device to appear active (although there may be no system activity at the time). This is normal, and does not indicate a problem.

Failure Indications

An ISE may fail during initial power-up or during normal operation. The following table describes the states of the LEDs, what these states mean, and what actions you should take.

When . . .	It means . . .	And you . . .
The Ready LED is on and the Fault LED is off	the operating condition is normal	may use the ISE.
The Fault and Ready LEDs turn on and stay on	the ISE is unable to execute the POST	power down the system, check the DSSI cable, and try again. If failure persists, call Digital Customer Services.
Neither LED turns on	the correct amount of power may not be getting to the ISE	check the power supply cable and the DSSI cable. If failure persists, call Digital Customer Services.
The Fault LED turns on and stays on	a fault condition exists	run local programs, as described in Chapter 4, to isolate failure. If unable to access local programs, check the DSSI node ID. If failure persists, call Digital Services.

**Before
Calling Digital
Customer
Services**

If a failure occurs with the ISE, make sure:

- The ISE has the correct DSSI node ID
- No other device on the DSSI bus has the same node ID

Refer to Chapter 3 to make sure the DSSI node ID is set correctly. If the ID is set correctly and the ISE still fails, call Digital Customer Services.

6

Digital Customer Services

Types of Service Plans

- In this Chapter** This chapter describes a range of flexible services offered by Digital Customer Services.
- On-Site Service** On-site service offers the convenience of service at your site and insurance against unplanned repair bills. For a monthly fee, you receive personal service from our service specialists. Within a few hours, the specialist is dispatched to your site with equipment and parts to give you fast and dependable maintenance.
- BASIC Service** BASIC service offers full coverage from 8 a.m. to 5 p.m., Monday through Friday. Options are available to extend your coverage to 12-, 16-, or 24-hour periods, and to include Saturdays, Sundays, and holidays. Under the basic service plan all parts, materials, and labor are covered in full.

DECservice DECservice offers a premium, on-site service providing committed response to remedial service requests made during contracted hours of coverage. Remedial maintenance will be performed continuously until the problem is resolved, which makes this service ideal for customers requiring maximum service performance. Under DECservice all parts, materials, and labor are covered in full.

Carry-In service Carry-in service offers fast, personalized response, and the ability to plan your maintenance costs for a smaller monthly fee than On-Site Service. When you bring your unit to one of the many Digital SERVICenters worldwide, factory-trained personnel repair your unit within 2 days. This service is available on selected terminals and systems. Contact your local Digital Customer Services office to see if this service is available for your unit.

Digital SERVICenters are open during normal business hours, Monday through Friday.

DECmailer DECmailer offers expert repair at a per use charge. This service is designed for users who have the technical resources to troubleshoot, identify, and isolate the module causing the problem. Mail the faulty module to our Customer Returns Center where the module is repaired and mailed back to you within 5 days.

Per Call Service

Per call service offers a maintenance program on a noncontractual, time-and-materials-cost basis. This service is appropriate for customers who have the expertise to perform first-line maintenance, but may occasionally need in-depth support from Digital Services.

Per call service is available as a supplement to three of our service plans, as shown in the table below.

Service Plan	Turnaround Time	Coverage is Available . . .
BASIC	ASAP	12-, 16-, or 24-hours a day including weekends and holidays, depending on option chosen
On-Site	2 to 3 days	24 hours a day, 7 days a week
Carry-In	2 to 3 days	During normal business hours

For More Information

For more information on these service plans, prices, and special rates for volume customers, call the Digital Customer Services office nearest you.

Index

A

- Accessing local programs, 4-1
 - using console commands, 4-4
 - using MDM, 4-6
 - using VMS, 4-2

B

- BBR, 1-6

C

- Calibrations, 2-18, 2-29, 5-2
- Command flow, 2-15
- Command protection, 2-16

D

- Data flow, 2-13
- Data protection, 2-14
- Diagnostics, 2-28
- Diagnostics and utilities, 2-28, 2-31
- DIRECT, 2-32, 4-7
- Disk sector format, 2-23
- DKUTIL, 2-32, 4-25
 - command modifiers, 4-27
- DKUTIL commands, 4-26
 - DEFAULT, 4-29
 - DISPLAY, 4-30
 - DUMP, 4-32
 - EXIT, 4-35
 - GET, 4-36
 - HELP, 4-37
 - POP, 4-38

DKUTIL commands (cont'd)

- PUSH, 4-39
- REPLACE, 4-40
- SET SIZE, 4-41
- Drive module, 2-1, 2-33
 - block diagram, 2-12
 - controls and indicators, 3-16
 - DSSI node ID switches, 3-19
 - electronics, 2-9
 - interfaces, 2-5
 - LEDs, 3-20
- DRVEXR, 2-32, 4-8
 - dialogue, 4-9
 - modes, 4-10
- DRVST, 2-32, 4-11
 - dialogue, 4-11
 - error messages, 4-12
- DSA, 1-1
- DSSI bus, 1-2
- DSSI node ID plug, 3-3, 3-5, 3-15
- DUP server, 2-19, 2-28, 2-29

E

- ECC, 1-6, 2-23, 2-37
- ERASE, 2-32, 4-15
 - dialogue, 4-17
- Error codes, 2-34
- Error detection, 2-34
- Error handling, 2-23
- Error history, 2-35
- Error logs, 2-36

F

Failure indications, 5-3
Fault LED, 2-33, 3-1, 3-4, 3-6, 3-16, 5-3
Firmware structure, 2-17

H

HDA, 2-1, 2-3
HISTORY, 2-32, 4-14

I

ISE, 1-2

M

MSCP error logs, 2-36
 Bad Block Replacement Summary, 2-36
 Read/Write Error Log, 2-36
 Servo Performance Warning, 2-36
MSCP server, 1-2, 2-19
Multihost, 1-6, 2-20, 2-29

O

OCP, 3-1
 for BA200 series enclosure, 3-2
 for BA400 series enclosure, 3-5
Operator control panel, 2-33, 3-1

P

PARAMS, 2-18, 2-32, 2-34, 4-42
PARAMS commands, 4-43
 EXIT, 4-43, 4-44
 HELP, 4-43, 4-45
 LOCATE, 4-43, 4-46
 SET, 4-43, 4-47
 SET and SHOW parameters, 4-48
 SHOW, 4-43, 4-49
 SHOW classes, 4-50
 STATUS, 4-43, 4-52
 WRITE, 4-43, 4-54
 ZERO, 4-43, 4-56

Periodic tests, 2-18, 2-29, 5-2
POST, 2-28, 5-2
PRFMON, 2-32

R

RBN, 2-22
RCT cache, 1-6
RCT caching, 2-22
Read cache, 2-22
Ready LED, 3-4, 3-6, 3-16, 5-3
Request fragmentation, 1-6, 2-21
RF31 ISE
 description, 1-3
 specifications, 1-7
RF31F, 1-1
RF31F ISE
 specifications, 1-7
RF31T, 1-1
RF35/RF31T ISE
 description, 1-4
 specifications, 1-10
RF36 ISE
 description, 1-4
 specifications, 1-14
RF72 ISE
 description, 1-5
 specifications, 1-18
RF73 ISE
 description, 1-5
 specifications, 1-21
RF74 ISE
 description, 1-5
 specifications, 1-24

S

SCA, 1-2
Sector format, 2-23
Sector header process, 2-24
Seek ordering, 1-6, 2-21
Service plans
 BASIC service, 6-1
 Carry-in service, 6-2
 DECmailer, 6-2

Service plans (cont'd)

- DECservice, 6-2
- On-site service, 6-1
- Per call service, 6-3

Soft errors, 2-36

Specifications

- RF31 current and power, 1-8
- RF31 environmental, 1-9
- RF31 media, 1-8
- RF31 performance, 1-7, 1-10
- RF31F current and power, 1-8
- RF31F environmental, 1-9
- RF31F media, 1-8
- RF31F performance, 1-7, 1-10
- RF35/RF31T current and power, 1-11
- RF35/RF31T environmental, 1-12
- RF35/RF31T media, 1-11
- RF35/RF31T performance, 1-10
- RF36 current and power, 1-15
- RF36 environmental, 1-16
- RF36 media, 1-15
- RF36 performance, 1-14
- RF72 current and power, 1-19
- RF72 environmental, 1-20
- RF72 media, 1-19
- RF72 performance, 1-18
- RF73 current and power, 1-22
- RF73 environmental, 1-23
- RF73 media, 1-22
- RF73 performance, 1-21

- RF74 current and power, 1-25
- RF74 environmental, 1-26
- RF74 media, 1-25
- RF74 performance, 1-24

STATUS THREADS, 2-18

T

Transient errors, 2-35

V

VERIFY, 2-32, 4-19

- dialogue, 4-19
- error messages, 4-23
- warning messages, 4-24

W

Write-enabling

- a storage element, 3-7
- an RF35/RF31T storage element, 3-7 to 3-12
- an RF36 storage element, 3-7 to 3-12

Write-protecting

- a storage element, 3-7
- an RF35/RF31T storage element, 3-7 to 3-12
- an RF36 storage element, 3-7 to 3-12

