

InfoServer 100 System Operations Guide

Order Number: EK-DIS1K-UG-001

This guide describes how to operate an InfoServer 100 system.

Revision/Update Information: This is a new manual.

Digital Equipment Corporation

First Edition, October 1990

© Digital Equipment Corporation 1990

The following are trademarks of Digital Equipment Corporation:

DEC	PDP	ThinWire
DECconnect	P/OS	ULTRIX
DECmate	Professional	UNIBUS
DECnet	Q-bus	VAX
DECserver	Q22-bus	VMS
DECUS	Rainbow	VT
DECwriter	RSTS	VT100
DIBOL	RSX	Work Processor
MASSBUS	RT	

digital[™]

MS-DOS is a registered trademark of Microsoft Corporation.

This document was prepared with VAX DOCUMENT, Version 1.2.

Contents

PREFACE	ix
----------------	-----------

CHAPTER 1	SERVER DESCRIPTION	1-1
1.1	INFOSERVER 100 OVERVIEW	1-1
1.1.1	InfoServer 100 Functions	1-2
1.1.2	Server-Client Relationship	1-3
1.2	ESTABLISHING A SERVER MANAGEMENT SESSION	1-4
1.3	SERVER MANAGEMENT COMMANDS	1-6
1.4	HELP FACILITY	1-7
1.5	AUTOMATIC SERVICE POLICIES FOR MULTIPLE SERVERS	1-7
1.6	HIGH-AVAILABILITY FEATURE TO REDUCE SERVICE INTERRUPTIONS	1-8

CHAPTER 2	SERVER FUNCTIONS AND FEATURES	2-1
2.1	LAD AND LAST PROTOCOLS	2-1
2.1.1	LAST	2-2
2.1.2	LAD	2-2
2.2	AUTOMATIC MOUNTING OF COMPACT DISCS	2-3
2.3	INTERNAL READ/WRITE DISK FUNCTIONS	2-3

2.4	SERVICE RATINGS	2-4
2.5	INFOSERVER NAMING CONVENTIONS	2-5
2.5.1	InfoServer Name	2-5
2.5.2	Service Names	2-6
2.5.3	Partition Names	2-7
2.5.4	Device Names	2-7
2.6	SERVICE CLASSES	2-9
2.7	INFOSERVER READ/WRITE ACCESS POLICIES	2-9
2.8	MOP FUNCTIONS	2-10
2.8.1	MOP Identify Self	2-11
2.8.2	MOP Read Counters	2-11
2.8.3	MOP Loop Messages	2-11
2.8.4	MOP Downline Loading	2-11

CHAPTER 3	SERVER MANAGEMENT COMMANDS	3-1
------------------	-----------------------------------	-----

3.1	COMMAND SYNTAX CONVENTIONS	3-1
3.1.1	InfoServer Commands	3-2
3.1.2	Special Keys	3-2
3.1.3	Wild Card Matching	3-3
	CLEAR	3-4
	COPY	3-5
	CREATE PARTITION	3-7
	CREATE SERVICE	3-9
	DELETE PARTITION	3-13
	DELETE SERVICE	3-14
	EXIT	3-17
	HELP	3-18
	INITIALIZE	3-19
	LOOP	3-20
	MONITOR	3-21
	REBOOT	3-22
	RESTORE	3-23
	SAVE	3-25

SET PARTITION	3-27
SET SERVER AUTOMOUNT	3-28
SET SERVER GROUP CODES	3-29
SET SERVER IDENTIFICATION	3-31
SET SERVER MOP	3-32
SET SERVER MULTICAST	3-33
SET SERVER NAME	3-34
SET SERVER PASSWORD	3-35
SET SERVER STATE	3-36
SET SERVER WORK GROUP	3-37
SET SERVER WRITE ACCESS	3-38
SET SERVICE	3-40
SHOW DEVICE	3-44
SHOW ETHERNET	3-47
SHOW LAT	3-52
SHOW MOP	3-56
SHOW PARTITIONS	3-60
SHOW SERVER	3-63
SHOW SERVICE	3-66
UPDATE MOP	3-70
UPDATE SYSTEM	3-72
ZERO ALL	3-74
ZERO ETHERNET	3-75
ZERO LAT	3-76
ZERO MOP	3-77
ZERO SERVER	3-78

CHAPTER 4 PERFORMING ADVANCED FUNCTIONS	4-1
4.1 SERVING REGULARLY UPDATED COMPACT DISCS	4-2
4.2 ASSIGNING PASSWORDS TO PROTECT COMPACT DISCS	4-3
4.3 SERVING MEDIA UNDER SEVERAL NAMES	4-3
4.4 CREATING AND SERVING PARTITIONS	4-4
4.5 SERVING AN EXTERNAL READ/WRITE DISK	4-6

4.6	BACKING UP READ/WRITE DATA	4-7
4.6.1	Backing Up Data Locally	4-7
4.6.2	Backing Up Data Remotely	4-8
4.7	CREATING MOP PARTITIONS FOR DOWNLINE LOADING	4-9

CHAPTER 5	TROUBLESHOOTING	5-1
------------------	------------------------	------------

5.1	CANNOT CONNECT TO THE INFOSERVER DISK	5-1
5.2	ACCESS TO INFOSERVER DISKS SEEMS SLOW	5-9
5.3	CANNOT ENTER INFOSERVER COMMANDS FROM A LOCAL CONSOLE	5-10
5.4	CANNOT ENTER INFOSERVER COMMANDS FROM A REMOTE CONSOLE	5-12
5.5	INFOSERVER SOFTWARE WILL NOT BOOT	5-17
5.6	ONLINE HELP NO LONGER AVAILABLE	5-19
5.7	INFOSERVER DOES NOT BOOT COMPLETELY	5-20
5.8	INFOSERVER DOES NOT MOP DOWNLINE LOAD SYSTEMS	5-22
5.9	FORGOT THE INFOSERVER PASSWORD	5-27

APPENDIX A	INFOSERVER V1.0 COMMAND SUMMARY	A-1
-------------------	--	------------

APPENDIX B	SERVER MESSAGES	B-1
-------------------	------------------------	------------

B.1	INFORMATIONAL MESSAGES	B-2
------------	-------------------------------	------------

B.2	ERROR MESSAGES	B-3
------------	-----------------------	------------

B.3	WARNING MESSAGES	B-8
------------	-------------------------	------------

INDEX	Index-1
--------------	----------------

FIGURES

1-1	InfoServer Serving Clients	1-3
------------	-----------------------------------	------------

TABLES

1	Conventions	xi
1-1	InfoServer 100 Command Set	1-6
2-1	DK<i>n</i>: Devices	2-8
3-1	InfoServer Special Keys	3-2
3-2	Valid Class Names	3-10
3-3	Valid Class Names	3-15
3-4	Class Descriptions	3-41
3-5	SHOW DEVICE Display Fields	3-45
3-6	SHOW ETHERNET Display Fields	3-48
3-7	SHOW LAT Display Fields	3-53
3-8	SHOW MOP Display Fields	3-57
3-9	SHOW PARTITIONS Display Fields	3-62
3-10	SHOW SERVER Display Fields	3-64
3-11	SHOW SERVICE Display Fields	3-68

Preface

Purpose of This Guide

This guide describes the set of commands used to manage the InfoServer 100 virtual disk server for Ethernet networks. You can use these commands to set up services for client systems on the network. The guide also provides troubleshooting information to help solve problems that affect InfoServer 100 software operations.

For information on installing and troubleshooting the InfoServer 100 system hardware, see the *InfoServer 100 Installation and Owner's Guide*.

For information on managing a VMS client node, see the *VMS LAD Control Program (LADCP) Manual*.

Who Should Use This Guide

This manual is intended for network managers.

Structure of This Guide

This guide contains five chapters and two appendices.

- Chapter 1, "Server Description," provides a functional overview of the InfoServer 100 system and describes how to establish a management session on the Infoserver. The chapter also introduces you to the InfoServer 100 command set.

- Chapter 2, “Server Functions and Features,” describes InfoServer 100 features and functions, such as automatic mounting of compact discs, device-naming conventions to simplify access, and downline-loading capabilities.
- Chapter 3, “Server Management Commands,” describes all the InfoServer 100 commands, including format, parameters, and examples.
- Chapter 4, “Performing Advanced Functions,” describes advanced features for setting up customized configurations and provides examples.
- Chapter 5, “Troubleshooting,” provides information to identify solve common operating problems.
- Appendix A, “InfoServer V1.0 Command Summary,” provides a quick-reference summary of the command syntax for each InfoServer command.
- Appendix B, “Server Messages,” lists and describes informational and error messages.

Related Documents

You can order the following documents from Digital. Not all documents are available in every country. Check with your Digital sales representative for availability.

Title	Order Number
InfoServer 100 Installation and Owner's Guide	EK-DIS1K-IN
VMS LAD Control Program (LADCP) Manual	AA-PD1LA-TE

Conventions

The following conventions are used in this guide (Table 1):

Table 1: Conventions

Convention	Meaning
<code>Return</code>	A key name is shown enclosed to indicate that you press a key on the keyboard.
UPPERCASE	Uppercase letters indicate that you enter a command (for example, enter SHOW/SET).
<i>Red</i>	<i>Red</i> type denotes user input in examples.
Note	Notes provide general information about the current topic.
<i>bootstrap</i>	New terms are highlighted in text.

Server Description

This chapter provides a functional overview of the InfoServer 100 system. The chapter describes the basic methods of establishing a server management session and introduces you to the InfoServer commands.

The chapter covers the following topics:

- InfoServer 100 overview
- Establishing a server management session
- Server management commands
- Server HELP facility
- Automatic service policies and availability features

1.1 InfoServer 100 Overview

The InfoServer 100 is an Ethernet-based, high-performance, virtual disk server. It can serve physical disk media and sets of logical disk blocks to the network. Host systems running the appropriate client software can connect to virtual disks served by the InfoServer 100 and use them as though they were locally attached devices.

The InfoServer 100 is a *virtual disk* server. Unlike a *file* server, the InfoServer 100 does not impose a file system on the virtual disks that it serves. This means the InfoServer can serve a disk with any type of on-disk file structure. The host client system interprets the on-disk structure itself, allowing each host system to use its own native file system. Multiple on-disk structures can be served and accessed on a single InfoServer 100 at the same time.

1.1.1 InfoServer 100 Functions

The InfoServer 100 has a number of functions:

- **Make compact discs available to clients on the network.**
The InfoServer 100 serves compact discs automatically, using their volume label as the service name when the server is booted, or when compact discs are inserted in their drives. You do not have to perform an management action. Client systems simply bind to and mount the compact discs under their volume labels.

The InfoServer can automatically serve compact discs that are in ODS-2, ISO-9660, or High Sierra format. Other media type can be served manually through the InfoServer 100 management interface.
- **Serve read/write disk partitions.**
A partition is a logical subset of a read/write disk. A single disk can be subdivided into several partitions, each of which can be served to the network independently. To remote client systems, these partitions appear to be whole disks. For example, an MS-DOS PC using the PCSA product can access InfoServer 100 partitions and use them as though they were a local hard disk.
- **Act as an initial load system for some new VAX processors.**
The InfoServer can downline load the primary bootstrap program to these VAX systems, by handling maintenance operation protocol (MOP) requests. The VAX then connects back to the VMS software distribution compact disc and allows the BACKUP utility to make a copy of the VMS operating system savesets from the compact disc onto a read/write disk attached to the VAX. All subsequent VMS boots are then done from the local read/write disk. See Section 2.8.4 for information on downline loading.
- **Downline load other products.**
The InfoServer 100 can be used to load any Ethernet product that requests a particular file name to be loaded; that is, the product does not require an NCP database entry to locate the required file. Special MOP partitions can be created, and the desired file copied to that partition. Each InfoServer can handle up to 100 simultaneous downline loads more efficiently than host-based downline loaders, which must start processes to assist in the load.

1.1.2 Server-Client Relationship

Figure 1-1 shows the relationship of the InfoServer 100 to several possible client systems. In this example, the four compact disc drives connected to the server appear to the client systems as though they were physically connected to the clients. The VAX systems and workstation may be using one or two of the compact discs for VMS software distribution and online documentation, while the personal computer (PC) may be running the MS-DOS operating system and referencing a disk partition on the InfoServer. <popup

Figure 1-1: InfoServer Serving Clients

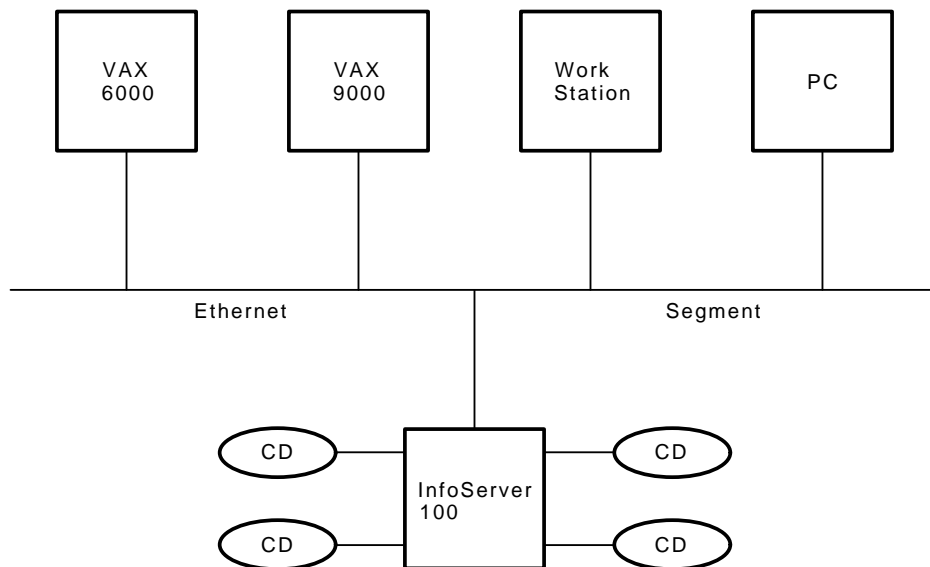

MA-0705-90.DG

You can simply connect the InfoServer 100 connect to your Ethernet local area network and turn it on. After the server is initialized, or *bootstrapped*, the server software automatically makes available, or *serves*, to client systems the disk media connected to it. For example,

if you insert a compact disc into a server drive, the server detects this new media and automatically serves it to client systems by using the volume label as the service name.

The server bootstraps from its internal RZ23 read/write disk drive, which has the InfoServer 100 software preinstalled. Any future InfoServer software updates will be distributed on compact discs. As these new releases become available, you can install the software onto the internal RZ23 disk for subsequent booting.

You may want to customize server features. You can control the server by logging into the server and entering server commands, described in Chapter 3.

1.2 Establishing a Server Management Session

You, the server manager, can establish a server management session from a local or remote console terminal:

- **For a local session**, you connect a terminal capable of interpreting VT100 ANSI escape sequences to the MMJ serial port 1 on the rear of the InfoServer 100 system unit.

NOTE

This terminal must be set to 9600 baud, 8 bits, no parity.

- **For a remote session**, you make a connection to the InfoServer 100 through a local area terminal (LAT) server.

Like many host systems, the InfoServer 100 will advertise a LAT service for its management interface and accept connections from remote terminals attached to terminal servers. Therefore, any terminal attached to a terminal server on the extended local area network (LAN) can act as a console terminal for the InfoServer 100 (if the user knows the InfoServer management password).

Determining the Server's Default Service Name

To make a remote connection to the InfoServer 100 for the first time, you must first determine the server's default name. To do this, add the four-character prefix *LAD_* to the hexadecimal Ethernet datalink address on the inside of the InfoServer 100's front panel. You can change this default name by using the SET SERVER NAME command (Chapter 3).

The server's name is the service name to connect to. For example, if the default server name is LAD_08002B15009F, then you would enter the following command at the terminal server's prompt to manage the InfoServer 100:

```
Local> CONNECT LAD_08002B15009F
```

NOTE

See your terminal server user's guide to learn more about the establishment of LAT service connections.

Entering an InfoServer Password

After you connect to the InfoServer, you must enter an InfoServer password to establish the management session. The default server password is *ESS*. You can change the password with the SET SERVER PASSWORD command (Chapter 3).

Sample Session

The following example shows the establishment of a sample session using a DECserver 500 terminal server:

```
Local> CONNECT LAD_08002B133C1C
Password: ESS (not echoed)
Local -010- Session 1 to LAD_08002B133C1C established
```

```
DEC InfoServer V1.0
```

```
InfoServer> SHOW SERVER
```

In this example, the terminal server's prompt is *Local>*, and a LAT session is established to the InfoServer 100 whose service name is LAD_08002B133C1C. The system server requires a server password to be entered. When the correct password is entered, the server prompts for the InfoServer commands with the *InfoServer>* prompt.

Ending a Session

At the end of the management session, you can exit by entering EXIT at the *InfoServer>* prompt. This action returns you to the terminal server's *Local>* prompt if the management session is over a LAT connection.

1.3 Server Management Commands

Table 1–1 introduces you to the set of InfoServer 100 commands, described in Chapter 3.

Table 1–1: InfoServer 100 Command Set

Command	Function
CLEAR	Erases the screen of the terminal running the management session.
COPY	Copies data from one disk or partition to another disk or partition.
CREATE	Creates a new partition on a read/write media, or a new service for clients to connect to.
DELETE	Deletes a partition or service that was previously created.
EXIT	Terminates the management session.
HELP	Displays help text for the InfoServer 100 commands.
INITIALIZE	Formats a read/write disk into an InfoServer 100 disk.
LOOP	Automatically repeats any valid InfoServer 100 command.
MONITOR	Automatically repeats valid InfoServer 100 commands every 3 seconds.
REBOOT	Shuts down and reboots the server.
RESTORE	Resets the server to a previously saved system configuration.

Table 1–1 (Cont.): InfoServer 100 Command Set

Command	Function
SAVE	Takes a snapshot of the state of the running server, for use in state recovery after a server reboot.
SET	Sets partition, service, or server parameters.
SHOW	Displays the server's parameters and counters.
UPDATE	Updates the system information for the server.
ZERO	Sets internal server counters to zero.

1.4 HELP Facility

The InfoServer 100 provides a HELP facility that contains information about each server command, including parameters, qualifiers, and examples of its use. See the HELP command description in Chapter 3 for more information about the HELP facility.

1.5 Automatic Service Policies for Multiple Servers

The InfoServer 100 automatically serves local disk media to clients when the server is first powered on or when a removable media (compact disc) is inserted in a drive. The server reads the volume label of each piece of media and uses the labels as the names of the services offered to clients.

Multiple servers may offer the same services. In this case, the client uses a rating scheme to select the appropriate service. See the SERVE DEVICE and SERVE PARTITION command descriptions in Chapter 3 for more information.

NOTE

You can disable the automatic service feature by using the SET SERVER AUTOMOUNT command.

When you remove a compact disc from a server disc drive, the InfoServer ends all client connections to the associated service. The InfoServer also stops offering, or *unserves*, the associated service to client systems.

1.6 High-Availability Feature to Reduce Service Interruptions

The InfoServer 100 provides a high-availability feature that is especially beneficial for VMS clients. If the server ends a service connection for some reason (for example, the server reboots, or the you remove a compact disc), the VMS client enters mount verification for that disk volume. If the same service is offered elsewhere on the network, then the VMS client will automatically fail over to the other volume.

For example, suppose you have two identical copies of the VMS Online Documentation compact disc inserted into drives on two different servers. If the original service is broken, the connection will fail over to the second compact disc. Your file operations will continue as normal, and you will experience almost no service disruption.

Server Functions and Features

This chapter provides information on the following topics:

- LAD and LAST protocols
- Automatic mounting of compact discs
- Use of the internal read/write disk
- Service ratings
- Naming conventions
- Service classes
- Read/write access policies
- MOP functions

2.1 LAD and LAST Protocols

The InfoServer uses the local area disk (LAD) and local area systems transport (LAST) protocols to provide access to the virtual disks it serves to the LAN network. This protocol pair provides high-performance access to disks in an extended local area network (LAN). The InfoServer implements the *InfoServer* portion of the LAD/LAST protocols, while the host systems that access disks on the InfoServer implement the *client* portion of the protocols.

2.1.1 LAST

The LAST protocol is a specialized transport that allows many clients to access InfoServers and perform reliable transactions. For the InfoServer, a transaction is a disk read or write operation. LAST allows many host client systems to read and write disk information concurrently to an InfoServer.

Unlike timer-based protocols, LAST is a transaction-oriented protocol. Normally, information does not pass between a client and an InfoServer unless the client initiates a transaction. The client system then runs a timer on the transaction, normally waiting from 2 to 5 seconds before assuming the transaction was lost and retrying the operation.

The LAST protocol does not provide any routing functions, so LAST runs only in a LAN network. LAST uses protocol type 80–41. If the extended LAN uses any filtering devices, they must allow this protocol type to pass unfiltered so InfoServers can be accessed across the filtering device.

The InfoServer uses a multicast address feature of LAST to establish connections to disks. The format of the multicast address is 09–00–2B–04–*xx-xx*, where *xx* depends on the work group enabled (Chapter 3).

2.1.2 LAD

The LAD protocol is a specialized disk protocol that uses the LAST protocol as a transport. That is, LAD messages are delivered in LAST messages. The LAD protocol provides the mechanism for reading and writing logical disk blocks independent from any underlying file system. The host clients that implement LAD interpret the file system locally. By using the LAD protocol for disk access, the InfoServer can support multiple host operating systems and disk file structures concurrently.

The LAD protocol also provides the naming facility to access disks. Each virtual disk is assigned a name by the InfoServer. The LAD protocol allows clients to query the LAN network for service names available. When the requested service is found, the client connects to it, and disk access can begin. When duplicate virtual disks are available under duplicate service names, LAD provides a facility for load balancing among the available disks (Section 2.4).

2.2 Automatic Mounting of Compact Discs

The InfoServer has can automatically recognize newly installed media, read the media's volume label, and make that volume label name available to the LAN network. This process is called the *automount* feature. You can enable or disable the automount feature with the SET SERVER AUTOMOUNT command (Chapter 3).

With the automount feature enabled, there is no need for any InfoServer management commands to access compact discs. The InfoServer automatically makes the compact discs available to client systems. Client systems simply use their native access method to connect to the volume label name.

The InfoServer automatically serves any compact discs that are present when the InfoServer boots. It also detects and serves new compact discs that are inserted while the InfoServer is running. If a compact disc is removed while the InfoServer is running, then the InfoServer deletes the volume label service, and any client connections to the compact disc are broken. If the same compact disc is reinserted into the InfoServer, client connections are reestablished. If a different compact disc is reinserted, then it is automatically served with its own volume label.

If you do not know the volume label of a compact disc, then you can use the InfoServer management interface to determine the volume label. After inserting the compact disc, enter the SHOW DEVICE command at the *InfoServer>* prompt. This display lists the volume labels for all compact discs on the system. See the SHOW DEVICE command description in Chapter 3.

2.3 Internal Read/Write Disk Functions

The InfoServer comes with an internal RZ23 read/write disk. The InfoServer software uses this disk to store InfoServer parameters, characteristics, and other information specific to the InfoServer. This internal disk is preinitialized and loaded with the InfoServer operational software. Therefore, special care must be taken when allowing remote client access to this disk.

Partitions

Normally, any InfoServer disk (a disk that has been initialized with the InfoServer INITIALIZE command) is not served to the LAN network as a whole disk. Instead, logical subdisks called *partitions* are served to the LAN network. A single InfoServer disk can be subdivided into several smaller partitions. Each partition can be treated as a whole disk by remote clients. Since partitions do not overlap, different systems can use different partitions without conflict. All InfoServer information is stored in special partitions. Therefore, this information is also protected from LAN network access to other partitions.

Serving an Entire Disk to the Network

There are special cases when you may wish to serve an entire InfoServer disk to the LAN network. One example of this might be to make a backup of the InfoServer disk on a remote client system. The remote client system should access the disk as if the online disk structure were unknown, since the disk structure is actually an InfoServer disk. For example, under the VMS operating system you would use a MOUNT/FOREIGN command. See Section 4.6 for an example of backing up InfoServer disks.

2.4 Service Ratings

The InfoServer provides static load balancing across duplicate media within an extended LAN. To do this, the InfoServer provides a *rating* for every service that it offers to the LAN network. When client systems request access to a service, they select among duplicate services by selecting the service with the highest rating. A higher rating indicates a more readily available service for client connections; a lower rating indicates lower availability. Clients will always select the service with the highest rating, whenever a service is offered more than once on the LAN network.

By default, the InfoServer dynamically calculates a rating based on the InfoServer load for each service. The dynamic rating for each service is calculated and updated every 10 seconds. The following algorithm is used to calculate the dynamic rating, within the LAD protocol range of 0 to 65535:

$$(32768 * \%CPU_free) + (32767 * ((0.9 * last_calc_srvd_load) + (0.1 * new_calc_srvd_load)))$$

The first term, called the server load factor, is simply an instantaneous look at the CPU percentage, weighted over one-half the rating scale.

The second term, called the service load factor, is 90 percent of the last calculated load factor plus 10 percent of the current calculated load factor, weighted over one-half the rating scale. The last load factor is then replaced with the current calculation of the service load factor. This produces a moving weighted average that is calculated at each timer interval, for each service. The formula for the *new_calc_srvd_load* term is as follows:

$$new_calc_srvd_load = \frac{1000 - \min(1000, \text{I/Os to service in last 10 sec})}{1000}$$

As a result, a load is imposed on the service based on the number of block reads in the past 10 seconds. The term *last_calc_srvd_load* is then updated with the new service load factor calculated.

Any service that is blocked by a write session to an overlapping virtual disk is assigned a rating of 0. See Section 2.7 for more information on concurrent read/write access.

2.5 InfoServer Naming Conventions

The InfoServer manages several different resources by using their assigned names. For example, services, logical disk partitions, and devices have assigned names. Assigning names to each resource makes it easier to access and manage InfoServer resources. Each resource has different policies that govern the names applied to those resources.

2.5.1 InfoServer Name

The InfoServer itself is assigned a name. Each InfoServer name must be unique within an extended LAN. The InfoServer name identifies the InfoServer unit. This name is also used as a LAT management service that is advertised to the LAN network.

When the InfoServer is shipped, the InfoServer software assigns each InfoServer unit a unique name. The default name is in the form LAD_XXXXXXXXXX, where XXXXXXXXXXXX is the hexadecimal ASCII representation of the InfoServer's Ethernet adapter address. An example is LAD_08002B15009F.

If you choose, you can change the InfoServer name to a name that is more meaningful for your particular environment. If you assign an InfoServer name, you must use the following sets of characters:

- A–Z
- a–z
- 0–9
- \$ (dollar sign)
- . (period)
- _ (underscore)
- - (hyphen)
- Multinational characters in the ASCII range 192–255

All InfoServer names are case-insensitive. For example, the InfoServer would treat an uppercase *A* and lowercase *a* as a match.

2.5.2 Service Names

The InfoServer can assign service names to devices and partitions. These service names are the access mechanism for remote client nodes. Clients specify the names of services that they wish to connect to. The InfoServer resolves the names down to the requested virtual disk, then completes the connection request.

Service names offered by the InfoServer are restricted to the same set of characters used for InfoServer unit names (Section 2.5.1)

Note that some compact discs may have volume labels that contain characters other than those listed in Section 2.5.1. If the InfoServer is configured to automount compact discs, it is unable to automatically serve compact discs whose volume labels contain characters outside the normal set. For these compact discs, you have to create a service manually. See the CREATE SERVICE command (Chapter 3).

It is possible to have identical media or data available on the extended LAN concurrently. Therefore, it is possible to have the same service name available within the extended LAN. A service name may be available more than once on a single InfoServer, or may be available on more than one InfoServer. When redundant service names are available on the LAN, clients use load balancing to select the least busy media. If one service in the LAN should fail, clients will try to automatically reconnect, or *fail over*, to another available service.

2.5.3 Partition Names

The InfoServer can create logical sets of blocks, called *partitions* on read/write media. A partition is a subset of a physical read/write device that can be served to the LAN network as though it were an entire disk. As the InfoServer creates these partitions, it also assigns each partition a name.

Partition names are local to the InfoServer. Partition names are not visible to remote client systems. Clients gain access to partitions through the use of service names. The partition names are only used by the InfoServer command set for ease of management. Partition names are unique within a single read/write media.

Partition names created by the InfoServer are also restricted to the same set of characters used for InfoServer unit names (Section 2.5.1).

2.5.4 Device Names

The InfoServer can support up to nine disk drives that are designated as devices. The system has two buses designated as SCSI-A and SCSI-B. Each bus can support up to seven devices each. SCSI-A is an internal bus that has a compact disc drive and a read/write drive preconfigured into the system. SCSI-B is an external bus that may have a second compact disc drive preconfigured into the system, depending on your InfoServer model. You can add external disk devices to the SCSI-B bus.

Each device on each bus is assigned a number from 0 to 7 that is set by switches on the device. The InfoServer assigns a device name to each device of the form *DKn*, where *n* is a device number greater than or equal to 0. Device numbers are assigned in ascending order, starting with 0. The numbering starts with the SCSI devices on SCSI-A and continues with SCSI-B. Table 2-1 lists the full range of *DKn*: devices available to the system.

Table 2-1: DKn: Devices

Switch ID	Unit Number	Device	DKn:
SCSI-A Bus			
0 0 0	0	Unused	DK0:
0 0 1	1	Preconfigured read/write disk	DK1:
0 1 0	2	Preconfigured compact disk	DK2:
0 1 1	3	Unused	DK3:
1 0 0	4	Unused	DK4:
1 0 1	5	Unused	DK5:
1 1 0	6	CPU bus position	Reserved
1 1 1	7	Unused	DK7:
SCSI-B Bus			
0 0 0	0	Available for expansion	DK8:
0 0 1	1	Available for expansion	DK9:
0 1 0	2	Available for expansion	DK10:
0 1 1	3	Available for expansion	DK11:
1 0 0	4	Available for expansion	DK12:
1 0 1	5	Preconfigured or available	DK13:
1 1 0	6	CPU bus position	Reserved
1 1 1	7	Available for expansion	DK15:

2.6 Service Classes

Since the InfoServer is a virtual disk server rather than a file server, it can support multiple operating systems and multiple on-disk file structures concurrently. The InfoServer provides a means for logically subdividing the services offered on the LAN network into groups that are meaningful to each client system. These logical subdivisions are based on *service classes*.

A service class divides the different virtual disks that the InfoServer offers to the LAN network into different name spaces. Each client system only accesses the name space that is meaningful to it. For example, VMS accesses services that are offered under the ODS-2 name space, while ULTRIX systems access services under the ULTRIX name space.

Services classes provide a mechanism for segregating service names. If the same service name were used in two different service classes, then each client system would only see the service in its own name space. For example, a VMS client system would never accidentally connect to an ULTRIX disk.

When it automounts a new compact disc, the InfoServer creates a service under the service class that is appropriate for the disk structure found on the compact discs. For example, if the InfoServer reads the volume label from an ISO-9600 compact disc, it creates a service with the volume label as the name under the ISO-9600 service class.

The InfoServer can automatically serve compact discs that are ODS-2, ISO-9660, and High Sierra format. You can use InfoServer commands to serve other media types under any of the supported service classes. Chapter 3 describes the available service classes and the InfoServer commands.

2.7 InfoServer Read/Write Access Policies

The InfoServer is a virtual disk server. Since it does not impose an underlying file structure on the disks it serves, the InfoServer does not provide a locking mechanism to prevent concurrent write access to the same sets of disk blocks. Instead, the InfoServer enforces a connection policy that prevents such conflicts that could result in data corruption.

You can select one of two policies:

- By default, the InfoServer only allows write access to a virtual disk after all other read access has been disconnected. For example, a LAN network write-access connection would immediately disconnect all read-access connections that conflict with the write-access request, then allow write-access after all readers are disconnected. Readers will also be blocked from reconnecting to those same disk blocks for the duration of the write-access connection.

This type of policy is ideally suited for classes of data that are infrequently updated, but frequently read. Readers are prevented from reading bad data while the write-access connection updates the data. After the write-access connection is terminated, the readers will reconnect to the updated data.

- The second policy that the InfoServer can enforce is to block write-access while there is a read conflict present. Instead of immediately disconnecting any read-only connections, the write-access connection is delayed until all read connections are disconnected voluntarily by the remote clients.

This policy is ideally suited for information that must be highly available for read-access, but may be updated during off hours.

For either policy, the InfoServer prevents concurrent access during write operations. This local locking policy guarantees data integrity.

Note that because partitions do not overlap on an InfoServer disk, write access to one partition does not prevent read or write access to a different partition. Locking will only occur for requests to the same partition, or to the same disk volume.

For more information on setting the InfoServer write access policy, see the `SET SERVER WRITE ACCESS` command description in Chapter 3.

2.8 MOP Functions

The InfoServer implements several features of the maintenance operations protocol (MOP) of the DECnet Digital Network Architecture. The following sections describe supported features.

2.8.1 MOP Identify Self

The InfoServer responds to MOP “request identity” messages that it receives. The InfoServer responds with a MOP “system identification” message to the requesting node.

The Infoserver also broadcasts a system identification periodically to the LAN network. The InfoServer responds with SVA as its communication device type.

2.8.2 MOP Read Counters

The InfoServer responds to MOP “request counters” messages that it receives. The InfoServer responds with a MOP “counters” message to the requesting node.

2.8.3 MOP Loop Messages

The InfoServer responds to MOP “loop direct” and MOP “loop assist” messages that it receives. The InfoServer returns the loop data as directed in the received loop request. For example, on a VMS system you can test Ethernet connectivity with the InfoServer by using the NCP LOOP CIRCUIT command; from a terminal server, you can use the TEST LOOP command.

2.8.4 MOP Downline Loading

The InfoServer can be configured to act as a MOP downline load server. This means the InfoServer can receive downline load requests, and downline load the requesting system, if the requested load image is present. You can enable or disable this feature for individual InfoServers by using InfoServer commands (Chapter 3).

The InfoServer can handle up to 100 concurrent downline loads. Unlike host-based downline load servers that must start processes to assist in the loading process, the InfoServer can handle downline load requests quickly and efficiently. The InfoServer can provide an ideal solution for LAN network conditions where many systems attempt to downline load

at the same time, such as when a power failure occurs in a terminal server LAN network.

The InfoServer handles a subset of all possible MOP downline load requests. Specifically, the requesting system must supply a file identifier for the InfoServer to downline load it. Since the InfoServer does not have a load database such as the one present with NCP, the InfoServer must rely on the remote system to indicate the image that it needs downline loaded.

When the InfoServer receives a load request that it can possibly service, it searches all of its read/write disks for special MOP partitions. MOP partitions are special partitions that are capable of being downline loaded. For information on installing MOP partitions for downline loading, see Section 4.7.

Server Management Commands

This chapter describes the InfoServer management commands and provides examples of their use.

3.1 Command Syntax Conventions

The following conventions apply to the commands in this chapter:

Convention	Meaning
UPPERCASE	Words in uppercase indicate a command or command option that you enter as shown.
Lowercase	Words in lowercase indicate parameters that you specify.
[]	Options are enclosed in brackets ([]).
{ }	Choices between two or more options are enclosed in braces ({ }). Choices are separated by a vertical bar ().
SYNCHRONIZED (D)	A (D) indicates the default setting for a command option when there is a choice of two or more option settings.

3.1.1 InfoServer Commands

The chapter describes the following commands:

CLEAR
COPY
CREATE
DELETE
EXIT
HELP
INITIALIZE
LOOP
MONITOR
REBOOT
RESTORE
SAVE
SET
SHOW
UPDATE
ZERO

3.1.2 Special Keys

The InfoServer management console reserves certain keyboard keys for special functions. Table 3–1 lists the reserved keys that the InfoServer console uses and the function each key provides.

Table 3–1: InfoServer Special Keys





	Deletes the previous character in the current command line
	Ends the current command line. The InfoServer executes the command.
	Recalls the last InfoServer command executed. The InfoServer saves the last 10 commands executed at the console.
	Deletes all characters in the current command line.

Table 3–1 (Cont.): InfoServer Special Keys

<code>Ctrl Z</code>	Displays “Exit” in reverse video and ends the command line. The InfoServer executes the command.
---------------------	--

3.1.3 Wild Card Matching

Some InfoServer commands allow wild card operations. If you use a wild card string in an InfoServer command, then all objects matching the wild card string are used in the specified operation.

The InfoServer uses two wild card characters:

- * Matches any number of any characters in the current character position.
- % Matches exactly one character in the current character position.

For example, suppose you entered the following command:

```
InfoServer> SHOW SERVICE AB%DE*
```

The InfoServer would select all services whose names start with the letters AB, followed by any one character, followed by the letters DE, followed by any number of any characters.

CLEAR

CLEAR

Clears the screen of a video terminal capable of interpreting VT100 ANSI escape sequences.

Format **CLEAR**

Parameters

None.

Description

The CLEAR command erases the screen of a terminal that is capable of receiving VT100 ANSI escape sequences.

Example

```
InfoServer> CLEAR 
```

The terminal screen is erased as soon as you press the key.

COPY

COPY

Copies data from one disk or partition to another disk or partition.

Format **COPY** *DKn:[partition_name] DKn:[partition_name]*

Parameter

DKn:[partition_name]

DKn: specifies a valid InfoServer device, as defined in Section 2.5.4.

The *partition_name* specifies a partition name that already exists on the specified device. If you do not specify a partition name, the entire disk is copied.

Description

You use the **COPY** command to make copies of data from one InfoServer disk or partition to another disk or partition. The first parameter specifies the source of the copy. The second parameter specifies the destination of the copy. For the copy to complete successfully, the size of the source and destination must be the same. If the destination specifies a partition name that does not exist, then the system creates the destination partition.

To preserve data integrity, the InfoServer does not allow copy operations unless you have set the InfoServer state to off. This prevents remote virtual disk operations and local disk operations from interfering with each other. See the **SET SERVER STATE** command in this chapter.

A side effect of performing a copy operation is that the copy blocks all other local operations to the source and destination devices. This action ensures that local users do not corrupt each other by copying data to the same disk partitions.

COPY

Example

```
InfoServer> COPY DK1:MY_PARTITION DK11:SAVE_PARTITION
%ESS-I-CREATED, Create partition completed successfully.
%ESS-I-COPIED, Copy operation completed successfully.
```

This command copies the data in a partition named MY_PARTITION on device DK1: to a partition named SAVE_PARTITION on device DK11. The message following the command indicates that DK11:SAVE_PARTITION did not exist, so the InfoServer created it and continued with the copy operation.

CREATE PARTITION

CREATE PARTITION

Makes a partition on a read/write media.

Format **CREATE PARTITION** *DKn:partition_name BLOCKS
value [options]*

Parameter

DKn:partition_name

DKn specifies a valid InfoServer device, as defined in Section 2.5.4.

partition_name specifies a partition name that does not already exist on the specified device.

value

Specifies the block size of the partition to be created. One block is equal to 512 bytes of disk storage.

Options

MOP DISABLED (D)

The MOP DISABLED option specifies that the partition will not be used to contain an image file that the InfoServer can downline load using MOP (Section 2.8). MOP DISABLED is the default if the option is omitted.

MOP ENABLED

The MOP ENABLED option specifies that the partition will be used to contain an image file that the InfoServer can downline load using MOP. The InfoServer will only downline load images from partitions that have MOP ENABLED.

NOTE

A partition specified as a MOP partition cannot be served to the LAN network as a virtual disk. MOP partitions are only for downline loading.

CREATE PARTITION

Description

You use the `CREATE PARTITION` command to create a partition on a read/write media. Partitions are a subset of logical blocks on a physical media that can be served to the LAN network as a disk. The actual size of the partition may be larger than the number of specified blocks if the InfoServer reuses a previously deleted partition, or optimizes the partition size for its own internal disk structure.

See the `SHOW PARTITIONS` command for information on specified and actual sizes.

Example

```
InfoServer> CREATE PARTITION DK1:VIRTUAL_DISK BLOCKS 1024  
MOP DISABLED  
%ESS-I-CREATED, Create partition completed successfully.
```

This command creates a partition named `VIRTUAL_DISK` with 1024 blocks on disk `DK1:` and with MOP disabled.

CREATE SERVICE

Table 3–2: Valid Class Names

Class	Description
V2.0	Names understood by PCSA MS-DOS clients
UNFORMATTED	Virtual disk that has no format
MSDOS	MS-DOS virtual disks
ODS_2	VMS virtual disks
ULTRIX	ULTRIX virtual disks
ISO_9660	ISO 9660 compact disc format
HIGH_SIERRA	MS-DOS compact disc format

Default: ODS_2.

DYNAMIC_RATING (D)

Specifies that the InfoServer should calculate a rating for this service dynamically. This is the default method for service ratings.

NOPASSWORD

Specifies that there is no password required to access this service.

NOREADERS

Specifies that no readers are allowed to connect to this service. This is equivalent to setting READERS to 0.

NOWRITERS

Specifies that no writers are allowed to connect to this service. This is equivalent to setting WRITERS to 0.

PASSWORD password-string

Specifies an optional access control password for the service. The password string may be up to 39 alphanumeric ASCII characters in length. After you set a password, a client must specify the password to access the service. If you do not specify a password in this command, then clients are not required to provide a password to access the service.

You can enter the password without having it echoed on the screen, by entering the PASSWORD option as the last option in the CREATE SERVICE command. After entering the keyword PASSWORD, press Return. The InfoServer will prompt you for the password.

CREATE SERVICE

STATIC_RATING rating

Is a rating from 0 to 65535, used for load balancing across redundant services. Clients will choose a higher rating over a lower one. If you omit the `STATIC_RATING` option, the InfoServer calculates a dynamic rating based on InfoServer load.

READERS number

Specifies the maximum number of client connections allowed for read access. A value of 0 indicates write-only access, as qualified by the `WRITERS` option, if present. If a client requests read-only access or read/write to the service, then one reader is counted against this number.

Default: 1000 readers

WRITERS number

Specifies the maximum number of client connections allowed for write access. A value of 0 indicates read-only access, as qualified by the `READERS` option, if present. If a client requests write-only access, one writer is counted against this number. If a client requests read/write to the service, then one writer and one reader are counted.

Default: 1 for read/write media, 0 for compact discs

NOTE

The InfoServer does not allow more than one writer to connect to a read/write service at one time. See the `SET WRITE ACCESS` command for more information on the write access policies described in Section 2.7.

Description

The `CREATE SERVICE` command creates a LAN network service that represents either an entire disk or a partition on a disk.

NOTE

When you turn the InfoServer on or insert a compact disc while the InfoServer is on, the InfoServer software tries to automatically serve the disk. The InfoServer uses the volume label as the service name, along with the default parameters specified in the `CREATE SERVICE` command. You can

CREATE SERVICE

disable this feature with the `SET SERVER AUTOMOUNT` command.

Example

```
InfoServer> CREATE SERVICE ONLINE_DOC FOR DK2:  
CLASS ODS_2 PASSWORD NEWCD NOWRITERS  
%ESS-I-CREATED, Create service completed successfully.
```

This command tells the server to create a service named `ONLINE_DOC` that is password-protected, with a password of `NEWCD`. This service is associated with device `DK2` and is write-protected by the `NOWRITERS` option.

DELETE PARTITION

DELETE PARTITION

Deletes an existing partition.

Format **DELETE PARTITION** *DKn:partition_name*

Parameter

DKn:partition_name

DKn: specifies a valid InfoServer device, as defined in Section 2.5.4.

The *partition_name* specifies a partition name that already exists on the specified device.

Description

You use the DELETE command to delete a partition that has been previously created. If the partition has been served to the LAN network, then the services bound to the partition are also deleted.

The InfoServer prompts you for confirmation if you try to delete a partition that currently has remote clients connected to it.

Deleted partitions are marked, then reused when new partitions are created. You can use the SHOW PARTITIONS command with the FULL option to display all the deleted partitions on a disk.

Example

```
InfoServer> DELETE PARTITION DK1:VIRTUAL_DISK
%ESS-I-DELETED, Delete partition completed successfully.
```

This command deletes the partition named VIRTUAL_DISK on disk DK1 and makes the space available for reuse.

DELETE SERVICE

Table 3-3 lists valid *class_name* values for this qualifier.

Table 3-3: Valid Class Names

Class	Description
V2.0	Names understood by PCSA MS-DOS clients
UNFORMATTED	Virtual disk that has no format
MSDOS	MS-DOS virtual disks
ODS_2	VMS virtual disks
ULTRIX	ULTRIX virtual disks
ISO_9660	ISO 9660 compact disc format
HIGH_SIERRA	MS-DOS compact disc format

Description

The DELETE SERVICE command deletes an existing service from the InfoServer. Client systems can no longer access devices or partitions under the deleted service name.

The DELETE SERVICE command lets you delete all instances of a service name or a particular service name qualified by device and class name. You may use the *DKn:partition_name* and CLASS options to specify the exact service name you want to delete. If you want to delete all instances of a service name, then omit these parameters.

The DELETE SERVICE command warns the LAN network manager if clients are connected to the specified service name. The LAN network manager has the option to either delete the service (terminating the sessions connected) or abort the DELETE SERVICE command.

DELETE SERVICE

Example

```
InfoServer> DELETE SERVICE CD_DOC_00661 FOR DK11: CLASS ODS_2
Warning: 5 users are connected to CD_DOC_00661
Do you still want to delete CD_DOC_00661 [NO]? YES
%ESS-I-DELETED, Delete service completed successfully.
```

This command returns a warning, because the specified service name has client systems connected to it. The manager is asked if the service should still be deleted. In this example the answer is yes, so the remote users are disconnected from this service.

EXIT

EXIT

Terminates the InfoServer management session.

Format **EXIT (or LOGOUT)**

Parameters

None.

Description

You use the EXIT command to log out of the InfoServer and terminate the InfoServer management session after all management functions are complete. On the console terminal, you are prompted for the login password again before you can enter more commands. On a remote LAT management terminal, the LAT session is disconnected. The LOGOUT command is functionally equivalent to EXIT.

Example

```
InfoServer> EXIT
```

This command ends the current server management session.

HELP

HELP

Provides online help information for using the InfoServer management commands.

Format **HELP** *[topic] [subtopic...]*

Parameter

topic, subtopic...

You use the HELP command to obtain online help for any of the InfoServer commands. You can specify the topic and subtopic that you want help on. If you do not specify a topic, the system displays a list of topics and prompts you for a selection.

Description

The HELP command is an online reference for InfoServer commands. After you view an initial help display, press `[Return]`. The help display stops and the *InfoServer>* prompt is displayed.

If you do not specify a command name, the HELP command displays general information on the commands for which help is available. If you specify a command name, you obtain syntax information on that command. If you enter the HELP command with a command name only, such as HELP SHOW, the InfoServer displays a list of all of the command keywords used with the SHOW command.

Example

```
InfoServer>  HELP SERVE
```

This command displays a description of the SERVE command and the command format.

INITIALIZE

INITIALIZE

Formats a read/write disk into an InfoServer disk.

Format **INITIALIZE** *DKn:*

Parameter

DKn:
DKn: is a valid InfoServer device, as defined by Section 2.5.4.

Description

The INITIALIZE command is used to format a read/write disk into an InfoServer disk capable of supporting partitions or storing system configuration information. Initializing a disk destroys any data already stored on the disk.

By default, the single read/write disk preconfigured with the InfoServer is already initialized.

Example

```
InfoServer> INITIALIZE DK1:  
%ESS-I-INIT, Initialize completed successfully.
```

This command initializes disk DK1.

NOTE

When you initialize an InfoServer device, any data on the device is lost. This includes any configuration information that may have been saved previously.

LOOP

LOOP

Automatically repeats any valid command.

Format **LOOP** *[command]*

Parameter

command

Specifies a valid InfoServer command. If you do not specify a command, the InfoServer prompts you for the command.

Description

You use the LOOP command to automatically repeat any valid InfoServer command. The LOOP command continues to repeat the chosen command until you press another key. To stop the LOOP command, press any key.

Example

```
InfoServer> LOOP SHOW SERVICE
```

This command repeats the SHOW SERVICE command automatically.

MONITOR

MONITOR

Repeats any valid InfoServer command every 3 seconds.

Format **MONITOR** *[command]*

Parameter

command

Specifies a valid InfoServer command. If you do not specify a command, the InfoServer prompts you for the command.

Description

You use the MONITOR command to automatically repeat any valid InfoServer command. The MONITOR pauses for 3 seconds between commands and moves the cursor to the home position on ANSI-type screens. This action makes the command useful for redisplaying SHOW command screens.

To stop the MONITOR command, press any key.

Example

```
InfoServer> MONITOR SHOW ETHERNET
```

This command repeats the SHOW ETHERNET command every 3 seconds, refreshing the screen for each display.

REBOOT

REBOOT

Ends all active service connections and reinitializes the InfoServer.

Format **REBOOT** *[YES]*

Parameter

YES
The YES reply initiates the shutdown procedure.

Description

You use the REBOOT command to reboot the InfoServer. The REBOOT command ends all active service connections by remote clients and starts the InfoServer bootstrap sequence.

If you omit the YES keyword, the InfoServer prompts you to confirm the shutdown.

Example

```
InfoServer> REBOOT
_Are you sure you want to reboot the InfoServer now [No]? YES
```

This command starts the reboot sequence. The user is asked to confirm the command.

RESTORE

RESTORE

Restores the system state and all services from the last saved configuration.

Format **RESTORE** [*DKn:*]

Parameter

DKn:

Specifies a valid InfoServer device, as defined in Section 2.5.4, to use for the restore procedure.

If you omit the device name, the InfoServer uses the DK1: device by default. DK1: is the read/write disk that comes with the InfoServer.

Description

You use the RESTORE command to restore a previously saved system configuration. The SAVE command lets you save any services offered with the CREATE SERVICE command, as well as any InfoServer characteristics changed with the SET command. The settings are saved on an InfoServer read/write disk. The RESTORE command resets the running InfoServer to its last saved settings.

NOTE

The RESTORE command does not delete any existing services before restoring previously saved services. Therefore, any saved services are added to the existing list of services.

RESTORE

Example

```
InfoServer> RESTORE DK1:  
%ESS-I-RESTORED, Restore completed successfully from DK1:
```

This command restores the last set of InfoServer services and settings saved on device DK1: to the running InfoServer.

SAVE

SAVE

Save the current system state to nonvolatile storage.

Format **SAVE** [DKn:]

Parameter

DKn:

Specifies a valid InfoServer device to use, as defined in Section 2.5.4.

If you omit the device name, the InfoServer uses the DK1: device by default. DK1: is the read/write disk that comes with the InfoServer.

Description

The SAVE command lets you save the current InfoServer state on a writeable InfoServer disk. This action allows the InfoServer to quickly restore information about services it is providing if an interruption occurs, such as a power failure or reboot. If you do not specify a device, the InfoServer uses the first writeable disk found in the configuration to store this information. When the InfoServer reinitializes, it searches all writeable disks for the first saved configuration information.

NOTE

Saving this information does not affect user data on the writeable disk if the disk has been initialized by the InfoServer. The InfoServer automatically preallocates space on initialized disks for this purpose by creating a partition named CONFIGURATION. To reset your InfoServer to the factory defaults, simply delete the partition named CONFIGURATION. If you want to save this file, copy it to a partition with a different name.

SAVE

Example

```
InfoServer> SAVE
%ESS-I-SAVED, Save operation completed successfully to DK1:
```

This command saves the InfoServer system state to the first writeable disk it finds.

SET SERVER AUTOMOUNT

SET SERVER AUTOMOUNT

Allows the InfoServer to automatically provide LAN network access to compact discs.

Format **SET [SERVER] AUTOMOUNT** *{ENABLED |
DISABLED}*

Parameter

ENABLED (D)

Enables the InfoServer to automatically serve compact discs by volume label when they are inserted and when the InfoServer boots. This is the default setting.

DISABLED

Disables the InfoServer from automatically serving any compact discs by volume label when they are inserted and when the InfoServer boots.

Description

The SET SERVER AUTOMOUNT command lets you determine whether or not the InfoServer will automatically serve the compact discs to the LAN network by volume label. When enabled, discs are served as they are inserted and when the InfoServer boots. The default setting is enabled.

Example

```
InfoServer> SET SERVER AUTOMOUNT DISABLED
%ESS-I-SET, Set operation completed successfully.
```

This command disables the automount feature of the InfoServer.

SET SERVER GROUP CODES

Description

The SET SERVER GROUP command lets you enable or disable the LAT group codes used by the InfoServer to advertise its management console. The codes range from 0 to 255. A terminal server must have at least one group code in common with the InfoServer set in order to connect to the management console.

Default : Group 0 is enabled.

Example

```
InfoServer> SET SERVER GROUP 1, 3, 10-20 ENABLED
%ESS-I-SET, Set operation completed successfully.
```

In this example, group codes 1, 3, and 10 to 20 are added to the group code list that the InfoServer currently offers.

SET SERVER IDENTIFICATION

SET SERVER IDENTIFICATION

Assigns a identification string to the InfoServer to be used by the LAT protocol.

Format **SET [SERVER] IDENTIFICATION** *"string"*

Parameter

string
Specifies a quoted text string of 0 to 64 printable ASCII characters.

Description

The SET SERVER IDENTIFICATION command assigns a text description to the InfoServer. The LAT protocol uses this description to identify the InfoServer.

Example

```
InfoServer> SET SERVER IDENTIFICATION "InfoServer Floor  
3-A by the coffee machine"  
%ESS-I-SET, Set operation completed successfully.
```

This command uses a text string that identifies an InfoServer by its location. This string is used to advertise the remote management service to terminal servers.

SET SERVER MOP

SET SERVER MOP

Determines whether or not the InfoServer can perform MOP downline load functions.

Format **SET [SERVER] MOP** *{ENABLED | DISABLED}*

Parameter

ENABLED (D)

Enables the InfoServer to perform MOP downline loading. This is the default setting.

DISABLED

Disables the InfoServer's downline-loading capability.

Description

The SET SERVER MOP command provides the InfoServer manager with a convenient way to enable or disable the InfoServer's MOP downline-loading capability. If the InfoServer does not need to perform MOP downline loading, then disabling the function can enhance the performance of the InfoServer.

For more information on the uses of downline loading, see Section 2.8.4.

Example

```
InfoServer> SET MOP DISABLED
%ESS-I-SET, Set operation completed successfully.
```

This command disables the InfoServer's MOP downline-loading function.

SET SERVER MULTICAST

SET SERVER MULTICAST

Sets a timer that determines how frequently the InfoServer advertises the LAT remote management interface.

Format **SET [SERVER] MULTICAST [TIMER] *timer_value***

Parameter

timer_value
Specifies a timer value, from 10 to 255 seconds.

Description

This command lets you control how frequently the InfoServer advertises the LAT remote management console interface.

Default: 60 seconds

Example

```
InfoServer> SET SERVER MULTICAST 120
%ESS-I-SET, Set operation completed successfully.
```

This command sets the InfoServer to advertise every 120 seconds.

SET SERVER NAME

SET SERVER NAME

Changes the name that the InfoServer is known by on the extended LAN.

Format **SET [SERVER] NAME** *server-name*

Parameter

server_name

Specifies the name of the InfoServer. The InfoServer uses a unique default name of the form LAD_ *ethernet_address* (for example, LAD_0800020000FF), until a new name is set with this command. The name may be up to 16 characters in length. Section 2.5.1 lists the characters you can use in InfoServer names.

Description

The SET SERVER NAME command lets you select a name string that the InfoServer will be known by on the extended LAN. This name allows you to easily identify an InfoServer by using the SHOW SERVER command. The InfoServer name is also used to provide a LAT service that you can connect to from a terminal, in order to manage the InfoServer.

NOTE

InfoServer names must be unique within the extended LAN.

Example

```
InfoServer> SET SERVER NAME LAB1_INFOSERVER
%ESS-I-SET, Set operation completed successfully.
```

This command sets the InfoServer name to LAB1_INFOSERVER.

SET SERVER PASSWORD

SET SERVER PASSWORD

Allows the InfoServer manager to change the InfoServer password.

Format **SET [SERVER] PASSWORD**

Parameter

None.

The SET SERVER PASSWORD command does not take a command qualifier. Instead, the InfoServer prompts you for the old password and the new password.

Description

The InfoServer password controls access to InfoServer management sessions. When the InfoServer manager connects to the InfoServer from the LAT or local terminal, the InfoServer prompts you for the InfoServer password before allowing the management session to take place.

Default: The default InfoServer password is ESS.

Example

```
InfoServer> SET SERVER PASSWORD
_Old_password:  ESS (not echoed)
_New_password:  SECRET (not echoed)
_Verification:  SECRET (not echoed)
%ESS-I-SET, Set operation completed successfully.
```

This command sets the InfoServer password to SECRET.

SET SERVER STATE

SET SERVER STATE

Determines whether or not new service connections are established.

Format **SET [SERVER] STATE** {*ON* | *OFF* | *SHUT*}

Parameter

ON

Tells the InfoServer to accept new connection requests.

OFF

Tells the InfoServer to end all current connections and not to accept new connections.

SHUT

Tells the InfoServer to keep all current connections, but not to accept new connections.

Description

The SET SERVER STATE command tells the InfoServer what actions to take when it receives a new service connection request from a client. The InfoServer state does not affect LAT connections used to manage the InfoServer.

Example

```
InfoServer> SET SERVER STATE SHUT
%ESS-I-SET, Set operation completed successfully.
```

This command shuts off new connections, but keeps all current connections. One possible use of this setting is when the InfoServer is scheduled to be turned off in the near future for maintenance.

SET SERVER WORK GROUP

SET SERVER WORK GROUP

Sets the work group of the InfoServer.

Format **SET [SERVER] WORK [GROUP] *value***

Parameter

value

Specifies a value, from 0 to 1023, that represents work group of this InfoServer.

Default: work group 0

Description

Work groups are a method of segmenting LANs so that services associated with certain nodes are not seen by other nodes. To access virtual disks on the InfoServer, client systems must belong to the same work group as the InfoServer.

One possible environment for this command is an extended LAN. Here, a LAN network manager may wish to restrict nodes to the services offered on their own LAN segments.

Example

```
InfoServer> SET SERVER WORK GROUP 1
%ESS-I-SET, Set operation completed successfully.
```

This command sets the InfoServer's work group to 1. The InfoServer will only communicate with client systems that are in work group 1.

SET SERVER WRITE ACCESS

SET SERVER WRITE ACCESS

Sets the write policies for the InfoServer to virtual disk services.

Format **SET [SERVER] WRITE [ACCESS] {SYNCHRONIZED
| BLOCKING}**

Parameter

BLOCKING

Tells the InfoServer to block writers from accessing a service until all readers have disconnected from the service.

SYNCHRONIZED (D)

Tells the InfoServer to allow writers to access a service and end all read sessions to the service. Synchronized is the default write access mode.

Description

The SET SERVER WRITE ACCESS command allows the LAN network manager to set the write policies that govern access to all services on a InfoServer. There are two choices—allow the readers to remain connected and deny access to the writer, or disconnect the readers and let the writer connect. Only one writer can access a service at a time, regardless of the policy.

One possible application of this command might be for nightly updates of a virtual disk. Each night a writer could connect to a service, disconnecting any read-only connections in order to update a central database. After the writer disconnects, the readers could reconnect and access the new data on the virtual disk.

SET SERVER WRITE ACCESS

Example

```
InfoServer> SET SERVER WRITE ACCESS SYNCHRONIZED
%ESS-I-SET, Set operation completed successfully.
```

This command tells the InfoServer to disconnect any read-only connections when a writer connects to a service.

SET SERVICE

SET SERVICE

Lets you modify the attributes of an existing service.

Format **SET SERVICE** *service_name* [*FOR*
DKn:[partition_name]
[CLASS class_name] [*options*]

Parameter

service_name

Specifies the name of a service to be modified. The service name can contain wild card characters.

DKn:[partition_name]

DKn refers to any InfoServer device, as defined in Section 2.5.4.

The *partition_name* specifies a partition name that already exists on the specified device.

Since an InfoServer may have two disk volumes with the same service name, this option lets you qualify which service you want to modify. If you omit this parameter, all service names that satisfy the other options are modified.

CLASS class_name

Specifies the name space that this service name exists in. If you include this parameter, the InfoServer searches only the specified class. If you omit this parameter, all service names that satisfy the other options are modified.

You use different name spaces for different on-disk structures used by various client systems. The purpose is to partition the name spaces so clients only see names that are meaningful to them. This method also allows two services to have the same name and not conflict.

SET SERVICE

The class name used depends on the client systems that will connect to the service being created. For example, VMS systems use the ODS-2 name space by default when attempting to mount an InfoServer device. Table 3-4 lists valid class name values.

Table 3-4: Class Descriptions

Class	Description
V2.0	Names understood by PCSA MS-DOS clients
UNFORMATTED	Virtual disk that has no format
MSDOS	MS-DOS virtual disks
ODS_2	VMS virtual disks
ULTRIX	ULTRIX virtual disks
ISO_9660	ISO 9660 compact disc format
HIGH_SIERRA	MS-DOS compact disc format

Default: ODS_2

Options

DYNAMIC_RATING (D)

Specifies that the InfoServer should calculate a rating for this service dynamically. This is the default method for the service ratings.

NOPASSWORD

Specifies that there is no password required to access this virtual disk.

NOREADERS

Specifies that no readers are allowed to connect to this service. This is equivalent to setting READERS to 0.

NOWRITERS

Specifies that no writers are allowed to connect to this service. This is equivalent to setting WRITERS to 0.

PASSWORD password-string

Specifies an optional access control password for the service. The password string may be up to 39 alphanumeric ASCII characters in length. After you set a password, a client must specify the password to

SET SERVICE

access the service. If you do not specify a password in this command, then clients are not required to provide a password to access the service.

You can enter the password without having it echoed on the screen, by entering the PASSWORD option as the last option in the CREATE SERVICE command. After entering the keyword PASSWORD, press `Return`. The InfoServer will prompt you for the password.

STATIC_RATING rating

Specifies a rating from 0 to 65535 to use for load balancing across redundant services. Clients will always choose a higher rating over a lower one. If you omit the STATIC_RATING option, the InfoServer calculates a dynamic rating based on InfoServer load.

READERS number

Specifies the maximum number of client connections allowed for read access. The default is 1000 readers. A value of 0 indicates write-only access, as qualified by the WRITERS option, if present. If a client requests read-only access or read/write access to the service then one reader is counted against this number.

WRITERS number

Specifies the maximum number of client connections allowed for write access. The default is one writer. A value of 0 indicates read-only access, as qualified by the READERS option, if present. If a client requests write-only access or read/write access to the service then one writer is counted against this number.

NOTE

The InfoServer will not allow more than one writer to connect to a read/write service at one time. See the SET WRITE ACCESS command for more information regarding the write access policies described in Section 2.7.

SET SERVICE

Description

The SET SERVICE command lets you modify the attributes of an existing service. The LAN network manager can change the rating, password, number of readers, or number of writers associated with a service.

You can modify all instances of a service name or a particular service name qualified by device and class name. You may use the *DKn:partition_name* and CLASS options to specify the exact service name you want to modify. If you want to modify all instances of a service name, omit these parameters. The service name can include wild card characters.

Example

```
InfoServer> SET SERVICE ONLINE_DOC FOR DK11: NOPASSWORD
%ESS-I-SET, Set operation completed successfully.
```

This command tells the InfoServer to remove the password currently required to access the ONLINE_DOC service, which represents the DK11: device.

SHOW DEVICE

SHOW DEVICE

Displays the characteristics and device-specific information about one or all disk devices connected to the InfoServer.

Format **SHOW DEVICE** *[DKn:] [BRIEF | FULL]*

Parameter

DKn:

Specifies a valid InfoServer device, as defined by Section 2.5.4. If you omit this parameter, the system displays all the devices on the InfoServer.

Options

FULL

The FULL option provides all device-specific information for the devices connected to the InfoServer. The FULL option lists all services bound to the device. FULL is the default if you specify a single device.

BRIEF

The BRIEF option provides an abbreviated one-line summary of information for each device connected to the system. BRIEF is the default if you omit the device name.

Description

The SHOW DEVICE command displays device-specific information for one or all devices connected to the InfoServer. This information includes the device type, device name, SCSI bus address, device size and the volume's label.

SHOW DEVICE

Examples

1. InfoServer> SHOW DEVICE

Device Name	Device State	Device Type	Device Address	Device Size	Volume Label
DK1:	On	Hard Disk	A/001	204864	BOOT_PAR
DK2:	On	Compact Disc	A/002	1216980	CD_DOC_01221
DK13:	On	Compact Disc	B/005	0	

This command displays a one-line summary of all devices connected to the InfoServer.

2. InfoServer> SHOW DEVICE DK2:

```
Device Name:          DK2:
State:                On           Device Size:          1216980
Device:               Compact Disc Volume Name:          CD_DOC_01221
SCSI Id:              2            Bus:                  A

Services bound to Port:
CD_DOC_01221         [ODS_2]
```

This command displays detailed information for device DK2, including the services offered for the device.

Table 3–5 describes the fields displayed in SHOW DEVICE commands.

Table 3–5: SHOW DEVICE Display Fields

Field	Description
Device name	The name that the InfoServer has assigned to the device.
Device state	The current state of the device. For this release, devices are always on.
Device type	The type of device attached to the unit. Device types are one of the following: Hard disk (read/write disk) Compact disc (CD)
Device address	The bus and unit number of the attached SCSI device.

SHOW DEVICE

Table 3-5 (Cont.): SHOW DEVICE Display Fields

Field	Description
Device size	The number of blocks available on the attached disk.
Volume label	The volume label for the media currently in the device.
Services bound to port:	A list of services that are currently available to the LAN network for the specified device.

SHOW ETHERNET

SHOW ETHERNET

Displays datalink and LAST protocol counters.

Format **SHOW ETHERNET [COUNTERS]**

Parameters

None.

Description

The **SHOW ETHERNET** command displays errors and counters kept by the InfoServer for the Ethernet datalink and for the LAST protocol.

Example

```
InfoServer> SHOW ETHERNET
DEC InfoServer 100 V1.0 (BL4) LAD V3.0 LAST V3.1 Uptime 000 00:01:35

Seconds Since Zeroed:      95   Frame Sent, 1 Collision:      1
Bytes Received:           37110  Frames Sent, 2+ Collisions:   0
Bytes Sent:                256   Send Failures:                0
Frames Received:          12949  Send Failure Reasons:        0000000000
Frames Sent:               4     Receive Failures:             0
Multicast Bytes Rcv'd:    37160  Receive Failure Reasons:      0000000000
Multicast Bytes Sent:      256   Unrecognized Destination:     12350
Multicast Frames Rcv'd:   12993  Data Overrun:                  0
Multicast Frames Sent:    4     User Buffer Unavailable:        0
Frames Sent, Deferred:    2     System Buffer Unavailable:      1

LAST Counters -
Messages Received:        246   Transaction Segments Missed:   0
Messages Transmitted:     0     Canceled Transactions:         0
Checksum OK:              0     Checksum Errors:               0
Multicast Msgs Rcv'd:     0     Congestion:                     0
```

Table 3-6 describes the fields displayed in **SHOW ETHERNET** commands.

SHOW ETHERNET

Table 3–6: SHOW ETHERNET Display Fields

Field	Description
DEC InfoServer V1.0 (base level)	The product designation and software version number.
LAD V3.0 LAST V3.1	The version number of the LAD and LAST protocols being used by the InfoServer.
Uptime	The time the InfoServer has been running since the last reboot. The time is shown in the format: days hours:minutes:seconds
Seconds Since Zeroed	The number of seconds since these counters were last set to 0.
Bytes Received	The number of bytes contained in datagrams successfully received by the InfoServer, excluding Ethernet header and CRC data.
Bytes Sent	The number of bytes contained in datagrams successfully transmitted by the InfoServer, excluding Ethernet header and CRC data.
Frames Received	The number of datagrams successfully received by the InfoServer, including multicast frames.
Frames Sent	The number of datagrams successfully transmitted by the InfoServer, including multicast frames.
Multicast Bytes Rcv'd	The number of bytes received by the InfoServer in multicast frames, excluding Ethernet header and CRC data.
Multicast Bytes Sent	The number of bytes transmitted by the InfoServer in multicast frames, excluding Ethernet header and CRC data.
Multicast Frames Rcv'd	The number of multicast frames received by the InfoServer.
Multicast Frames Sent	The number of multicast frames transmitted by the InfoServer.

SHOW ETHERNET

Table 3–6 (Cont.): SHOW ETHERNET Display Fields

Field	Description
Frames Sent, Deferred	The number of times that the InfoServer deferred a frame transmission because the datalink was in use.
Frames Sent, 1 Collision	The number of times the InfoServer transmitted a frame on the second attempt after a collision occurred on the first attempt.
Frames Sent, 2+ Collisions	The number of times the InfoServer successfully sent a frame after collisions during the first two or more attempts.
Send Failures	The number of times the Ethernet interface aborted a transmission request. If this count is not 0, see the Send Failure Reasons field for more information.
Send Failure Reasons	<p>A bit mask providing information about the send failure if the Send Failures counter is not 0. The bits in the mask are numbered from right to left, with bit 0 being the rightmost bit. The following bits are defined in the mask:</p> <ul style="list-style-type: none">0 A transmission failed to complete after 16 retries, usually due to excessive collisions.1 A loss of carrier occurred on the Ethernet during a transmission.2 A short circuit occurred on the Ethernet during a transmission.3 An open circuit occurred on the Ethernet during a transmission.4 Heartbeat error.5 Data underflow.
Receive Failures	The number of frames that were received with an error condition. For more information, see the Receive Failure Reasons field.

SHOW ETHERNET

Table 3–6 (Cont.): SHOW ETHERNET Display Fields

Field	Description
Receive Failure Reasons	<p>A bit mask providing information about the type of receive failures encountered if the Receive Failures counter is not 0. The bits in the mask are numbered from right to left, with bit 0 being the rightmost bit. The following bits are defined in the mask:</p> <p>0 A block check error. The received frame did not pass the CRC check.</p> <p>1 A framing error. The received packet did not contain an integral number of 8-bit bytes.</p>
Unrecognized Destination	<p>The number of frames received by the InfoServer that did not contain a multicast address or protocol type recognized by the InfoServer. These frames are discarded.</p>
Data Overrun	<p>The number of time that the InfoServer hardware lost an incoming frame because it was unable to keep up with the data rate.</p>
User Buffer Unavailable	<p>Currently unused. Should always be 0.</p>
System Buffer Unavailable	<p>The number of times that the InfoServer system software did not have a buffer available to receive an incoming frame (MISS error).</p>
Messages Received	<p>The number of LAST protocol messages successfully received by the InfoServer.</p>
Messages Transmitted	<p>The number of LAST protocol messages successfully transmitted by the InfoServer.</p>
Checksum OK	<p>The number of times that a LAST message was received that correctly passed the LAST checksum algorithm. LAST messages are only checksummed at the request of the client systems.</p>
Multicast Messages Rcv'd	<p>The number of LAST messages successfully received with the LAST multicast address.</p>

SHOW ETHERNET

Table 3–6 (Cont.): SHOW ETHERNET Display Fields

Field	Description
Transaction Segments Missed	The number of times that the InfoServer did not receive all the messages of a client request, when the client requested more than one message.
Canceled Transactions	The number of times that remote clients canceled a LAST request that the InfoServer was processing.
Checksum Errors	The number of times that a LAST message was received that did not pass the LAST checksum algorithm. LAST messages are only checksummed at the request of the client systems.
Congestion	The number of times that the client system and InfoServer agreed to reduce the LAN network rate due to too many messages being delivered to either the InfoServer or the client.

SHOW LAT

SHOW LAT

Displays the InfoServer's LAT counters and characteristics.

Format **SHOW LAT [COUNTERS]**

Parameters

None.

Description

The SHOW LAT command displays LAT characteristics set up for the InfoServer, as well as errors and counters kept by the InfoServer for the LAT protocol.

Example

```
InfoServer> SHOW LAT

                               * LAT Counters *
Seconds Since Zeroed: 106   Duplicates Received:           0
Messages Received:    0    Messages Retransmitted         0
Messages Transmitted: 3    Illegal Messages Received:    0
Slots Received:       0    Illegal Slots Received:       0
Slots Transmitted:    0    Virtual Circuit Timeouts:     0
Bytes Received:       0    Protocol Errors:               0
Bytes Transmitted:    0    Protocol Error Mask:          000000000000

                               * LAT Characteristics *
Name:                    TEST_INFOSERVER
Identification:          "Test InfoServer 100, near floor 3 copy machine"
Multicast timer:        60
Enabled Group Codes:    0, 12, 250-255
```

Table 3-7 describes the fields displayed in SHOW LAT commands.

SHOW LAT

Table 3–7: SHOW LAT Display Fields

Field	Description
Seconds Since Zeroed	The number of seconds since these counters were last set to 0.
Messages Received	The number of LAT protocol messages successfully received by the InfoServer.
Messages Transmitted	The number of LAT protocol messages successfully transmitted by the InfoServer.
Slots Received	The number of LAT slots received by the InfoServer. A slot represents a message segment for a particular LAT session.
Slots Transmitted	The number of LAT slots transmitted by the InfoServer. A slot represents a message segment for a particular LAT session.
Bytes Received	The number of data bytes received by the InfoServer over the LAT protocol.
Bytes Transmitted	The number of data bytes transmitted by the InfoServer over the LAT protocol.
Duplicates Received	The number of virtual circuit messages the InfoServer received that were not in the correct sequence.
Messages Retransmitted	The number of virtual circuit messages that the InfoServer retransmitted to remote nodes.
Illegal Messages Received	The number of incorrectly formatted LAT messages the InfoServer has received.
Illegal Slots Received	The number of incorrectly formatted slots of data in a LAT message that the InfoServer has received.
Virtual Circuit Timeouts	The number of times that the InfoServer terminated a LAT connection because the remote node did not respond within the time allowed by the LAT protocol.
Protocol Errors	The number of times that the InfoServer determined that the LAT protocol has been violated by a remote node. See the Protocol Error Mask field for more information.

SHOW LAT

Table 3–7 (Cont.): SHOW LAT Display Fields

Field	Description
Protocol Error Mask	<p>A bit mask providing information about the LAT protocol errors detected by the InfoServer. The bits in the mask are numbered from right to left, with bit 0 being the rightmost bit. The following bits are defined in the mask:</p> <ul style="list-style-type: none">0 An unknown LAT message type was received.1 An invalid LAT START message was received.2 A zero-valued virtual circuit reference was received.3 An out of range virtual circuit reference was received.4 A reference to a nonexistent virtual circuit was received.5 A reference to a virtual circuit no longer in use was received.6 An invalid LAT STOP message was received.7 An invalid reference to a remote slot was received.8 A reference to a nonexistent slot was received.9 A credit violation was detected.10 A repeated creation of a slot was detected.11 An invalid sequence number was received.12 A repeated disconnect of a slot was detected.

SHOW LAT

Table 3–7 (Cont.): SHOW LAT Display Fields

Field	Description
Name	The name of the InfoServer. This name is also the service name that terminal servers connect to in order to manage the InfoServer.
Identification	The identifying text string that the InfoServer uses to advertise to the terminal server network.
Multicast Timer	The number of seconds that the InfoServer uses to periodically advertise its remote management interface.
Enabled Group Codes	The group code numbers that the InfoServer is using to advertise its remote management interface.

SHOW MOP

SHOW MOP

Displays the server's MOP counters.

Format **SHOW MOP [COUNTERS]**

Parameters

None.

Description

The SHOW MOP command displays information on errors and counters kept by the InfoServer for the MOP protocol.

Example

```
InfoServer> SHOW MOP
                                     * MOP Counters *
Seconds Since Zeroed:      4697   Load failed, server limit:      0
Messages Received:        0       Load failed, not contiguous:     0
Messages Transmitted:     0       Load failed, file not found:     0
Messages Re-transmitted:  0       Load failed, read error:         0

Request IDs Received:     0       Load failed, timeout:            0
Read Counters Received:   0       Load failed, protocol error:     0
LOOP Messages Received:   0       Load failed, no memory:          0

Loads in progress:        0       Load failed, file too big:       0
Successful loads:         0       Load failed, bad file type:      0
Total loads processed:    0       Load failed, partition type:     0

*** MOP downline loading has been disabled.
```

Table 3–8 describes the fields displayed in SHOW MOP commands.

SHOW MOP

Table 3–8: SHOW MOP Display Fields

Field	Description
Seconds Since Zeroed	The number of seconds since these counters were last set to 0.
Messages Received	The number of MOP messages successfully received by the InfoServer.
LOOP Messages Received	The number of MOP LOOP messages that the InfoServer has received and responded to.
Messages Transmitted	The number of MOP messages successfully transmitted by the InfoServer.
Messages Re-transmitted	The number of MOP downline load messages that the InfoServer retransmitted to the requesting node.
Request IDs Received	The number of MOP request identity messages that the InfoServer has received and responded to.
Read Counters Received	The number of MOP request counters messages that the InfoServer has received and responded to.
Loads in progress	The current count of systems that the InfoServer is downline loading.
Successful loads	The number of times that the InfoServer successfully downline loaded a remote system.
Total loads processed	The total number of downline load requests that the InfoServer responded to, including successful and unsuccessful load attempts.
Load failed, server limit	The number of times that the InfoServer was unable to process a downline load request because it was currently handling the maximum number of concurrent downline loads.
Load failed, not contiguous	The number of times that the InfoServer was unable to process a downline load request, because an internal format error was detected in the downline load image.

SHOW MOP

Table 3–8 (Cont.): SHOW MOP Display Fields

Field	Description
Load failed, no memory	The number of times that the InfoServer was not able to complete a downline load request because it did not have sufficient memory pool.
Load failed, file not found	The number of times that the InfoServer received a downline load request, but did not have the requested downline load image.
Load failed, read error	The number of times that the InfoServer was unable to process a downline load because an error occurred while trying to read the disk.
Load failed, timeout	The number of times that the InfoServer began to process a downline load request, but terminated the downline load because the remote system did not complete the request within the time limit.
Load failed, protocol error	The number of times that the InfoServer was unable to complete a downline load request because it detected a downline load protocol error in the remote system's request.
Load failed, file too big	The number of times that the InfoServer attempted to process a secondary load request, but was unable to fit the entire image into a single MOP downline load message.
Load failed, bad file type	The number of times that the InfoServer was unable to complete a downline load request because it was unable to read the downline load file type in a partition.

SHOW MOP

Table 3–8 (Cont.): SHOW MOP Display Fields

Field	Description
Load failed, partition type	The number of times that the InfoServer located a partition with the name requested by the remote system, but was unable to downline load the image because the partition was not specified as a MOP partition.
*** MOP downline loading has been disabled	This field is only present if the InfoServer MOP characteristic has been disabled, indicating that the InfoServer will not process MOP downline load requests received.

SHOW PARTITIONS

SHOW PARTITIONS

Lists all the partitions on an InfoServer device.

Format **SHOW PARTITIONS** *DKn:[partition_name] options*

Parameter

DKn:[partition_name]

DKn: specifies a valid InfoServer device, as defined in Section 2.5.4.

The *partition_name* is a partition that already exists on the specified device. The partition name can contain wild card characters.

Options

FULL

The **FULL** option provides a display of all the specified device's partitions that match the specified input partition name, including any deleted partitions. The display also provides information on disk usage.

BRIEF

The **BRIEF** option provides a display of the specified device's named partitions that match the specified input partition name.

Description

You use the **SHOW PARTITIONS** command to list the partitions on an InfoServer device. The command lists partition names and sizes. The command can also list any deleted partitions available for reuse, as well as the remaining space on the disk. The **SHOW PARTITIONS** command supports full wild card expressions.

SHOW PARTITIONS

Examples

1. InfoServer> SHOW PARTITIONS DK1:C*

Directory DK1:

CONFIGURATION	11/16
CORPORATE_FISCAL_DATA	512/512
CORPORATE_POLICIES	1024/1024

DK1: has 6 partitions and has 204864 total blocks

This command lists the named partitions on disk DK1: that match the string C*.

2. InfoServer> SHOW PARTITIONS DK1: FULL

Directory DK1:

CONFIGURATION	11/16	
CORPORATE_FISCAL_DATA	512/512	
CORPORATE_POLICIES	1024/1024	
LAB_TEST_PARTITION	512/512	LAB_TEST_DATA [ODS_2]
PR0801ENG	387/400	MOP
	16/16	DELETED
	202384/202384	FREE

DK1: has 6 partitions and has 204864 total blocks

This command lists all the partitions on disk DK1, including any previously created partitions that have been deleted. The command also lists a summary of disk usage. Any services bound to a partition appear to the right of the partition size.

Partition DK1:LAB_TEST_PARTITION is currently being served with service name LAB_TEST_DATA, in the ODS_2 service class. This shows that VMS clients who binds to LAB_TEST_DATA will be accessing the partition DK1:LAB_TEST_PARTITION.

Table 3-9 describes the fields displayed in SHOW PARTITION commands.

SHOW PARTITIONS

Table 3–9: SHOW PARTITIONS Display Fields

Field	Description
<i>partition_name</i>	The name of the partition on the specified device.
<i>size/full_size</i>	The first size listed for the partition is the block size requested by the CREATE PARTITION command. This is the size used when served to the LAN network. The second size listed is the actual number of blocks that the InfoServer used (or reused) for the partition.
<i>service_name [service_class]</i>	Partitions listed with service names next are being offered as services to client systems. The service name is listed after the partition size with the service class in brackets.
MOP	Partitions listed with the MOP flag are MOP partitions capable of being downline loaded.
DELETED	Partitions listed with the DELETED flag are partitions that have been deleted and are available to for reuse when new partitions are created.
FREE	The FREE entry shows the number of unused disk blocks for the device. These blocks are free to be used in new partitions.
<i>Summary</i>	The last line indicates a summary of disk usage. This line lists the total number of named partitions on the disk, as well as the total number of blocks on the disk.

SHOW SERVER

SHOW SERVER

Displays the InfoServer's system characteristics, resources and counters.

Format SHOW SERVER [COUNTERS]

Parameters

None.

Description

The SHOW SERVER command displays information about the InfoServer system, including information about internal memory resource utilization, uptime, and idle time.

Example

```
InfoServer> SHOW SERVER
```

```
DEC InfoServer 100 V1.0      (X4.4)      System Image:  Aug  8 1990 15:50:43
Server Name:                TEST_ESS      Uptime:         002 18:51:54
Ethernet Address: 08-00-2b-16-02-9c      Current Sessions: 10
Server State:               On           Highest Sessions: 41
Write Access Policy:       Pre-emptive    Current Systems: 10
Current Work Group:        0             Highest Systems: 16
Pool Size:                  508632      Cache Size:     3161384
Pool Available:             230584      % of Pool Free: 45%
Cache Blocks Read:         59799129     Cache Hit Ratio: 11%
Disk Blocks Read:          91915529
Total Blocks Read:         151714782    Current Idle CPU: 53%
Total Blocks Written:      0           Low CPU:        38%
Enabled characteristics:
  MOP downline loading, Automount disks
```

SHOW SERVER

Table 3–10 describes the fields displayed in SHOW SERVER commands.

Table 3–10: SHOW SERVER Display Fields

Field	Description
DEC InfoServer V1.0 (base level)	The product designation and software version number.
Server Name	The name assigned to the InfoServer.
Ethernet Address	The Ethernet address of the InfoServer hardware unit.
Server State	The server state currently set for the InfoServer: ON, OFF, or SHUT.
Pool Size	The total number of bytes of memory available to the running software, for use in serving disks, accepting connections, processing MOP downline loads, and so on.
Pool Available	The total number of unused bytes of memory in the InfoServer pool.
Cache Blocks Read	The number of virtual disk blocks read by a remote client that were fetched from the disk cache (rather than from the disk).
Disk Blocks Read	The number of virtual disk blocks read by a remote client that were fetched from the physical disk (and not from cache).
Total Blocks Read	The total number of virtual disk blocks read by remote clients, from both disk and cache.
Total Blocks Written	The total number of virtual disk blocks that remote client systems wrote to an InfoServer disk.
System Image	The date when the InfoServer software was created.
Uptime	The time the InfoServer has been running since the last reboot. The time is in the following format: days hours:minutes:seconds

SHOW SERVER

Table 3–10 (Cont.): SHOW SERVER Display Fields

Field	Description
Write Access Policy	The current write-access policy in effect for the server, either preemptive or blocking.
Current Work Group	The work group that the InfoServer belongs to. The InfoServer only communicates with clients in the same work group.
Current Sessions	The number of remote client systems currently accessing virtual disks on the InfoServer.
Highest Sessions	The highest number of clients that concurrently accessed the InfoServer. This value is saved even when the server reboots.
Cache Size	The total number of bytes of memory being used as a disk cache for all InfoServer disks. As disk blocks are read, they are saved in memory for quicker access if those same blocks are read again.
% of Pool Free	The percentage of pool memory that is currently available.
Cache Hit Ratio	The percentage of times that the InfoServer was able to satisfy a client read request by getting the requested block(s) from cache.
Current Idle CPU	The percentage of the available CPU processing time that is currently free.
Low CPU	The lowest value for idle CPU time that the InfoServer has experienced since the last time the counters were set to 0.
Enabled characteristics	A list of all of the InfoServer characteristics that are currently enabled. Characteristics are separated by a comma.

SHOW SERVICE

SHOW SERVICE

Displays information about services.

Format **SHOW SERVICE** [*service-name* [*BRIEF* | *FULL*]]

Parameter

service-name

Specifies the name of the service to display. Usually, a service name is the same as the volume label of the disk volume. The service name can contain wild card characters. If you omit this parameter, the system displays information on all services.

Options

FULL

The **FULL** option provides detailed information about the specified service(s). **FULL** is the default if you specify a service name in the command line.

BRIEF

The **BRIEF** option provides an abbreviated, one-line summary of information for the specified service(s). **BRIEF** is the default if you do not specify a service name on the command line.

Description

The **SHOW SERVICE** command displays service-specific information for one or all services offered by the server. This information includes the device number associated with each service and the number of connected sessions. The **SHOW SERVICE** command supports full wild card expressions.

SHOW SERVICE

Examples

1. InfoServer> SHOW SERVICE *

```
CD_BIN_00122      [ODS_2]
CD_BIN_00121      [ODS_2]
CD_DOC_01221      [ODS_2]
FT_BOOT_PAR       [ODS_2]
```

This command displays summary information for all services.

2. InfoServer> SHOW SERVICE CD_DOC_01221 FULL

```
CD_DOC_01221      [ODS_2]
  Device Id:      DK2
  Service Rating: 32636   Disk Size:      1216980
  Rating:         DYNAMIC Password:         DISABLED
  Max Read Sess: 1000    MAX Write Sess: 0
  Cur Read Sess: 0       Cur Write Sess: 0
  Reads:         0       Writes:         0
  Block Reads:   0       Block Writes:   0
```

This command displays full information for the service CD_DOC_01221, which is offered for device DK2.

3. InfoServer> SHOW SERVICE MY_PARTITION FULL

```
MY_PARTITION      [ODS_2]
  Device Id:      DK2   Partition:      MY_PARTITION
  Service Rating: 32636   Disk Size:      1216980
  Rating:         DYNAMIC Password:         DISABLED
  Max Read Sess: 1000    MAX Write Sess: 0
  Cur Read Sess: 0       Cur Write Sess: 0
  Reads:         0       Writes:         0
  Block Reads:   0       Block Writes:   0
```

This command displays full information for the service MY_PARTITION, which is offered for the partition named MY_PARTITION on device DK2.

Table 3–11 describes the fields displayed in SHOW SERVICE commands.

SHOW SERVICE

Table 3–11: SHOW SERVICE Display Fields

Field	Description
<i>service_name</i>	The name assigned to each service listed in the display.
[<i>service_class</i>]	The name of the service class that the specified service is offered under; listed in square brackets ([]) after the service name.
Device Id	The name of the InfoServer device that the service is being offered for.
Service Rating	The service rating value (from 0 to 65535) currently assigned to the service.
Rating	The type of service rating assigned to the particular service. The rating type can be either STATIC or DYNAMIC.
Max Read Sess	The maximum number of concurrent read sessions allowed for the specified service.
Cur Read Sess	The current number of read sessions connected to the specified service.
Reads	The total number of read requests (of any size) issued by remote client systems for the specified service.
Block Reads	The total number of disk blocks that remote client systems have read for the specified service.
Partition	The partition name that the specified service is offered for. This field is not present if the service name is for an entire disk.
Disk Size	The total number of blocks on the disk that the service is being offered for.
Password	The current setting for password protection, ENABLED or DISABLED. The actual service password is not displayed.
Max Write Sess	The maximum number of concurrent write sessions allowed for the specified service.

SHOW SERVICE

Table 3–11 (Cont.): SHOW SERVICE Display Fields

Field	Description
Cur Write Sess	The current number of read sessions connected to the specified service.
Writes	The total number of write requests (of any size) issued by remote client systems for the specified service.
Block Writes	The total number of disk blocks that remote client systems have read for the specified service.

UPDATE MOP

UPDATE MOP

Updates the MOP images that the InfoServer can downline load.

Format **UPDATE MOP** *DKn: [DKn:]*

Parameter

DKn:

The first *DKn:* parameter specifies the source device where the new MOP downline loadable images will be copied from. The second *DKn:* parameter specifies the destination device where the new images will be copied to. Both *DKn:* parameters must specify a valid InfoServer device, as defined in Section 2.5.4.

If you omit the destination device, the InfoServer uses device DK1: by default. DK1: is the read/write disk that comes with the InfoServer.

Description

You use the UPDATE MOP command to install MOP images capable of being downline loaded onto the InfoServer. The MOP images comes on a special compact disc from Digital. The UPDATE MOP command loads the images from the compact disc onto the target disk you specify.

You must specify a source InfoServer device as the first parameter of the UPDATE MOP command. The second parameter is the destination device. If you omit the destination, the InfoServer copies the software to its internal read/write disk.

In order to preserve data integrity, you must set the InfoServer state to off before performing any UPDATE commands. This prevents remote virtual disk operations and local disk operations from interfering with each other. For more information, see the SET SERVER STATE command.

UPDATE MOP

Example

```
InfoServer> UPDATE MOP DK2: DK1:
Install DECserver 100 V2.0 software PS0801ENG.SYS [N]? YES
%ESS-I-COPIED, Copy operation completed successfully.
Install DECserver 200 V3.0 software PR0801ENG.SYS [N]? NO
Install DECserver 300 V1.0 software SH1601ENG.SYS [N]? NO
```

This command loads the MOP images from the compact disc in device DK2: to the internal read/write disk (DK1:).

UPDATE SYSTEM

UPDATE SYSTEM

Updates the InfoServer operational software used by the system.

Format **UPDATE SYSTEM** *DKn: [DKn:]*

Parameter

DKn:

The first *DKn:* parameter specifies the source device where the new InfoServer software will come from. The second *DKn:* parameter specifies the destination device where the new InfoServer software will be copied to. Both *DKn:* parameters must specify a valid InfoServer device, as defined in Section 2.5.4.

If you omit the destination device, the InfoServer uses the DK1: device by default. DK1: is the read/write disk that comes with the InfoServer.

Description

You use the UPDATE SYSTEM command to update the InfoServer software booted from a read/write media. The InfoServer software is preinstalled on the internal read/write disk. If you receive software updates on compact discs, you can use the UPDATE SYSTEM command to install the updated software on the read/write media.

You must specify a source InfoServer device as the first parameter of the UPDATE SYSTEM command. The second parameter is the destination device. If you omit the destination, the InfoServer copies the software to its internal read/write disk.

In order to preserve data integrity, you must set the InfoServer state to off before performing any UPDATE commands. This prevents remote virtual disk operations and local disk operations from interfering with each other. For more information, see the SET SERVER STATE command.

UPDATE SYSTEM

Example

```
InfoServer> UPDATE SYSTEM DK2: DK1:  
%ESS-I-COPIED, Copy operation completed successfully.
```

This command uses the InfoServer software on device DK2: to update the internal read/write disk (DK1:). This command lets you update the InfoServer's boot software on the internal read/write disk.

ZERO ALL

ZERO ALL

Resets all of the InfoServer's internal counters.

Format **ZERO ALL [COUNTERS]**

Parameters

None.

Description

The ZERO ALL command sets all of the internal counters kept by the InfoServer to 0.

Example

```
InfoServer> ZERO ALL
```

This command sets all counters associated with the operation of the InfoServer to 0.

ZERO ETHERNET

ZERO ETHERNET

Resets all of the Ethernet internal counters.

Format **ZERO ETHERNET [COUNTERS]**

Parameters

None.

Description

The ZERO ETHERNET COUNTERS command resets all of the Ethernet internal counters kept by the InfoServer. You can display these counters with the SHOW ETHERNET command.

Example

```
InfoServer> ZERO ETHERNET COUNTERS
```

This command sets all counters associated with the operation of the Ethernet datalink and LAST protocol to 0.

ZERO LAT

ZERO LAT

Resets the LAT internal counters kept by the InfoServer.

Format **ZERO LAT [COUNTERS]**

Parameters

None.

Description

The ZERO LAT COUNTERS command resets all of the internal LAT counters kept by the InfoServer. You can display the counters with the SHOW LAT command.

Example

```
InfoServer> ZERO LAT
```

This command sets all the counters that the InfoServer keeps for the LAT protocol to 0.

ZERO MOP

ZERO MOP

Resets the MOP counters.

Format **ZERO MOP [COUNTERS]**

Parameters

None.

Description

The ZERO MOP COUNTERS command resets all of the internal MOP counters kept by the InfoServer. You can display the counters with the SHOW MOP command.

Example

```
InfoServer> ZERO MOP
```

This command sets all the counters that the InfoServer keeps for the MOP protocol to 0.

ZERO SERVER

ZERO SERVER

Resets the InfoServer's internal counters.

Format **ZERO SERVER [COUNTERS]**

Parameters

None.

Description

The **ZERO SERVER COUNTERS** command resets all of the counters kept by the InfoServer for its own internal operations. You can display these counters with the **SHOW SERVER** command.

Example

```
InfoServer> ZERO SERVER
```

This command resets the counters that the InfoServer keeps for monitoring its internal operations, including the number of LAN network blocks read and written, and CPU utilization statistics.

Performing Advanced Functions

The standard InfoServer system provides transparent access to compact discs, without the need to enter any InfoServer management commands. However, for some customized configurations you may need to set up the system by using InfoServer commands.

This chapter describes some of the advanced functions you can perform by using InfoServer commands. Each section provides examples. The chapter describes how to perform the following functions:

- Assign a service name to a disk drive.
- Assign a password for access to a compact disc.
- Create multiple names for a service, to allow access by different operating systems.
- Create partitions to make use of open space on the internal read/write disk.
- Create services on external compact disc drives.
- Back up data locally or remotely.
- Downline loadable images from compact disc to the internal read/write disk.

4.1 Serving Regularly Updated Compact Discs

By default, a running InfoServer automatically serves compact discs to clients when you insert the discs. It also deletes services automatically when you remove compact discs. The InfoServer provides access to the current set of compact discs by their volume label.

Access by volume label is convenient for compact discs that remain in the InfoServer on a permanent basis. This method is also useful for temporary compact discs that will not be updated.

However, you may want to use a different method for compact disc subscriptions where information is updated regularly. When you remove an old disc and insert the updated copy, the automatically assigned service name usually changes because the updated media has a new volume label. For these cases, you may want to assign a single service name to the compact disc drive.

When you assign a single service name to a disc drive, clients can continue to use that name for connections when you insert a new disc. With a single service name, clients avoid the need to learn the volume labels of each new disc inserted.

To provide a fixed service name, you:

1. Assign the service name to a particular device.
2. Save the name, so it remains in effect whenever the InfoServer reboots.

Example

```
InfoServer> CREATE SERVICE CONDIST FOR DK2: CLASS ODS_2 WRITERS 0
%ESS-I-CREATED, Create service completed successfully.
InfoServer> SAVE
%ESS-I-MAVED, Save completed successfully to DK1:
InfoServer>
```

In this example, the InfoServer manager enters the service name CONDIST for an InfoServer compact disc drive that will serve Digital's consolidated distribution software disc. When a new compact disc is inserted, LAN network users can continue to connect to the service CONDIST: instead of having to learn the new volume label.

4.2 Assigning Passwords to Protect Compact Discs

By default, the InfoServer automatically makes every inserted compact disc available to all client systems on the LAN network. The InfoServer creates the service for each compact disc and uses default values for service-related options such as password protection. By default, password protection is off.

In some cases you may want to restrict access to information on compact discs by assigning a password. To provide password protection for compact discs, you:

1. Disable the automatic serving feature of the InfoServer.
2. Assign a service name and password for the selected compact disc.
3. Save the service name and password, so they remain in effect whenever the InfoServer reboots.

Example

```
InfoServer> SET SERVER AUTOMOUNT DISABLED
%ESS-I-SET, Set operation completed successfully.
InfoServer> CREATE SERVICE SENSITIVE_INFO FOR DK2: PASSWORD
_Password: SECRET (not echoed)
_Verification: SECRET (not echoed)
%ESS-I-CREATED, Create service completed successfully.
InfoServer> SAVE
%ESS-I-MAVED, Save completed successfully to DK1:
InfoServer>
```

In this example, the InfoServer manager assigns the service name `SENSITIVE_INFO` and the password `SECRET:` to the compact disc in the `DK2:` drive.

4.3 Serving Media Under Several Names

The InfoServer and host clients use protocols that allow for redundant virtual disks to be served on the LAN network with identical service names. The InfoServer also allows a single virtual disk to be served several times under several different names.

You may want to provide several different names for the same virtual disk, for the convenience of LAN network users. You may also want to make the same media accessible to more than one operating system. To assign several names to a virtual disk, you:

- Create several services with different names or service classes, all for the same device.
- Save the services, so the names and classes remain in effect whenever the InfoServer reboots.

Example

```
InfoServer> CREATE SERVICE RAW_DATA FOR DK2: CLASS ODS_2
%ESS-I-CREATED, Create service completed successfully.
InfoServer> CREATE SERVICE DATA_FROM_EXPERIMENT_2 FOR DK2: CLASS ODS_2
%ESS-I-CREATED, Create service completed successfully.
InfoServer> CREATE SERVICE RAW_DATA FOR DK2: CLASS ULTRIX
%ESS-I-CREATED, Create service completed successfully.
InfoServer> SAVE
%ESS-I-SAVED, Save completed successfully to DK1:
InfoServer>
```

In this example, the InfoServer manager assigns three aliases to the compact disc in the DK2: drive. The first two services are accessible from VMS, and the third from ULTRIX. This action assumes that the information on the disc is in a format that each operating system can read. Notice that the same name can be reused under different service classes.

4.4 Creating and Serving Partitions

The InfoServer has an internal RZ23 read/write disk used to store InfoServer parameters, configuration, and operational software. Since it uses the RZ23 disk for its own operations, the InfoServer normally does not make the disk available as a whole to the LAN network.

The InfoServer uses approximately 5000 to 10,000 disk blocks of the RZ23 disk, depending on how many services are saved. You can make the remaining free disk blocks available for general LAN network use, without interfering with the InfoServer data on the disk.

To make the remaining space available, you create partitions. You can create partitions on any disk that is initialized as an InfoServer disk.

To make read/write partitions available to the LAN network, you:

1. Create the partition(s) of the desired size.
2. Create services for each partition in the proper name space, with the appropriate read/write access and protection.
3. Save the services, so they are available whenever the InfoServer reboots.

Example

In the following example, the InfoServer manager creates three partitions to serve to the LAN network.

```
InfoServer> SHOW PARTITION DK1:
Directory DK1:
BOOT_PARTITION          5001/5002
CONFIGURATION           10/16
                       199864/199864  FREE

DK1: has 1 partition and 204864 total blocks

InfoServer> CREATE PARTITION DK1:ONLINE_HELP BLOCKS 20000
%ESS-I-CREATED, Create partition completed successfully.
InfoServer> CREATE SERVICE ONLINE_HELP FOR DK1:ONLINE_HELP
CLASS ODS_2 WRITER 0
%ESS-I-CREATED, Create service completed successfully.
InfoServer> CREATE SERVICE HELP_UPDATE FOR DK1:ONLINE_HELP
CLASS ODS_2 WRITER 1 PASSWORD
_Password: SECRET (not echoed)
_Verification: SECRET (not echoed)
%ESS-I-CREATED, Create service completed successfully.

InfoServer> CREATE PARTITION DK1:DOS_STORAGE1 BLOCKS 50000
%ESS-I-CREATED, Create partition completed successfully.
InfoServer> CREATE PARTITION DK1:DOS_STORAGE2 BLOCKS 50000
%ESS-I-CREATED, Create partition completed successfully.
InfoServer> CREATE SERVICE DOS_STORAGE FOR DK1:DOS_STORAGE1
CLASS V2.0 WRITER 1
%ESS-I-CREATED, Create service completed successfully.
InfoServer> CREATE SERVICE DOS_STORAGE FOR DK1:DOS_STORAGE2
CLASS V2.0 WRITER 1
%ESS-I-CREATED, Create service completed successfully.
InfoServer> SAVE
%ESS-I-SAVED, Save completed successfully to DK1:
InfoServer>
```

The first partition is used by VMS clients has two service names assigned. The first service is for read-only users to access online help. The second service is for the LAN network manager to gain write access to the same partition, in order to update online help.

The last two partitions are used by MS-DOS clients running PCSA. Notice that the PCSA product uses scratch disk storage in the V2.0 service class, not the MS-DOS service class.

4.5 Serving an External Read/Write Disk

You can add up to six external SCSI drives to the InfoServer system, on the external SCSI bus. You can use compact disc drives as external drives. The InfoServer handles external compact disc drives the same way as internal compact disc drives. For example, external compact discs are automatically served to clients when the discs are inserted.

You can also add external read/write drives as described in the *InfoServer Installation and Owner's Guide*. For read/write drives, the disk is normally unformatted. Since an unformatted disk does not have a volume label, it is not automatically served to the LAN network by the InfoServer.

To make the disk accessible, you:

- Create a service in the proper name space, with other desired settings.
- Save the service so it is always available whenever the InfoServer reboots.

Example

```
InfoServer> CREATE SERVICE RRD40 FOR DEVICE DK12: CLASS ODS_2 WRITERS 1
%ESS-I-CREATED, Create service completed successfully.
InfoServer> SAVE
%ESS-I-MAVED, Save completed successfully to DK1:
InfoServer>
```

After the InfoServer manager enters these commands, a client could bind to the service name RRD40, initialize the disk with an ODS-2 on-disk structure, mount the disk, and use the entire disk as if it were a locally attached RRD40.

4.6 Backing Up Read/Write Data

Since the InfoServer provides access to read/write storage, you may need to periodically back up the stored information. Backing up data allows you to restore information if the system has a disk failure, you replace an InfoServer unit, or any similar interruption occurs.

There are two methods available for backing up InfoServer data:

- If you have added a second read/write drive to the InfoServer, you can perform the backup operation locally by using InfoServer commands.
- You can also back up InfoServer disks to a remote client system, using the normal disk-access commands for your operating system to access the InfoServer.

The following sections describe how to perform local and remote backup operations.

4.6.1 Backing Up Data Locally

If you have added a read/write drive to your InfoServer, you can use InfoServer commands to back up data to that disk. For a local backup operation to succeed, the source and target disks must be the same size. If the disks are different sizes, you can create partitions.

To back up data on a local read/write disk, you:

1. Determine the size of the disk being backed up.
2. Initialize the external disk, so it can be used to create partitions.
3. Create the partition of the appropriate size.
4. Use the InfoServer's COPY command to save the data.

To restore the data, you would use the same COPY command but specify the partition as the source and the disk as the target.

Example

```
InfoServer> SHOW DEVICE DK1:

Device   Device      Device      Device      Device      Volume
Name     State       Type        Address     Size        Label
-----
DK1:     On          Hard Disk   A/001       204864      UNKNOWN

InfoServer> INITIALIZE DK12:
InfoServer> CREATE PARTITION DK12:SAVE_PARTITION BLOCKS 204864
%ESS-I-CREATED, Create partition completed successfully.
InfoServer> COPY DK1: DK12:SAVE_PARTITION
%ESS-I-COPIED, Copy operation completed successfully.
InfoServer>
```

In this example, the InfoServer manager backs up a smaller, internal RZ23 disk to a larger, external RRD40 disk. The manager initializes the RRD40 drive as device DK12:, then creates a partition on the RRD40 to match the storage size of the RZ23. The backup operation saves all of the system configurations, parameters, and operational software, as well as any partitions created.

4.6.2 Backing Up Data Remotely

You may want to back up data to a remote client system if:

- You do not have additional read/write disks on your InfoServer.
- You want to back up data to some other media, such as magnetic tape.

Example

This example shows how to back up data to a VMS system. Here are the basic steps:

1. On the InfoServer, make the entire disk available through a service.
2. On the VMS system, access the disk as though the online disk structure were unknown.
3. Perform the backup operation.

On the InfoServer:

```
InfoServer> CREATE SERVICE BACKUP FOR DK1: CLASS ODS_2
WRITERS 0 PASSWORD
_Password: SECRET (not echoed)
_Verification: SECRET (not echoed)
InfoServer>
```

Then, on the VMS system:

```
$ MCR ESS$LADCP
LADCP> BIND/PASSWORD=SECRET BACKUP
%LADCP-I-BIND, service bound to logical unit DAD$BACKUP (_DAD4:)
LADCP> EXIT
$ MOUNT/FOREIGN/NOWRITE DAD$BACKUP:
%MOUNT-I-MOUNTED,          mounted on _DAD4:
$ MOUNT/FOREIGN DKA200:
%MOUNT-I-MOUNTED,          mounted on _DKA200:
$ BACKUP/PHYSICAL DAD$BACKUP: DKA200:
$
```

Note that you could use any other operating system to perform this backup operation, as long as that system has client software to access the InfoServer. Simply use the appropriate commands for your operating system in place of the VMS commands in this example.

4.7 Creating MOP Partitions for Downline Loading

Normally, you create MOP partitions automatically when you use the InfoServer's UPDATE MOP command. The command creates the special MOP partitions on the read/write disk, then copies a set of downline loadable images from a compact disc to the MOP partitions. This single command procedure works only with downline loadable images supplied on compact discs from Digital.

If you have downline loadable images from other sources, you can take the following steps:

1. Determine the size of the downline loadable image.
2. Create a partition on the InfoServer to receive the image.
3. Create a service to access the partition from the client system.
4. Copy the image to the partition.
5. Delete the service for the partition. (MOP partitions cannot be served.)

6. Modify the partition to be a MOP partition.
7. Make sure that the MOP downline loading feature is enabled.

Example

This example shows the steps for downline loading a DECserver 200 that requests a file named PR0801ENG. The example uses VMS as the client system that has the downline loadable image. You could use any other operating system that has client access to the InfoServer; simply use the appropriate commands for your operating system in place of the VMS commands.

On the VMS system currently performing downline loading, issue a DIRECTORY command to determine the size of the downline loadable file. For example:

```
$ DIRECTORY/SIZE MOM$LOAD:PR0801ENG.SYS)
Directory SYS$COMMON:[MOM$SYSTEM]
PR0801ENG.SYS;1          378
$
```

From an InfoServer console terminal, enter the CREATE PARTITION command to set aside storage for the MOP downline loadable file. The partition name must be the same as the VMS file name, but without the extension (which is the name requested by the system being downline loaded). Serve the partition to the LAN network, so that the VMS system can copy the downline loadable file to the partition. For example:

```
InfoServer> CREATE PARTITION DK1:PR0801ENG BLOCKS 378)
%ESS-I-CREATE, Create partition completed successfully.
InfoServer> CREATE SERVICE MOP_UPDATE FOR DK1:PR0801ENG CLASS ODS_2
WRITER 1 PASSWORD
_Password: SECRET (not echoed)
_Verification: SECRET (not echoed)
%ESS-I-CREATED, Create service completed successfully.
InfoServer>
```

On the VMS client system, bind to the service under which the partition was served. Next, mount the device as a foreign device. Then copy the downline loadable file to the device connected to the partition.

```

$ RUN SYS$SYSTEM:ESS$LADCP
LADCP> BIND/WRITE/PASSWORD=SECRET MOP_UPDATE
%LADCP-I-BIND, service bound to logical unit DAD$MOP_UPDATE (_DAD3:)
LADCP> EXIT
$ MOUNT/FOREIGN DAD$MOP_UPDATE
%MOUNT-I-MOUNTED,          mounted on _DAD3:
$ COPY MOM$LOAD:PR0801ENG.SYS DAD$MOP_UPDATE:
$ DISMOUNT DAD$MOP_UPDATE
$

```

On the InfoServer console terminal, unserve the MOP partition to avoid possible corruption by other clients accidentally connecting to the MOP file. Then set the partition type to MOP and enable downline loading for the InfoServer. For example:

```

InfoServer> DELETE SERVICE MOP_UPDATE FOR DK1:PR0801ENG CLASS ODS_2
InfoServer> SET PARTITION DK1:PR0801ENG MOP
InfoServer> SET SERVER MOP ENABLED
InfoServer> SAVE
%ESS-I-SAVED, Save completed successfully to DK1:
InfoServer>

```

The InfoServer is now capable of downline loading any system that requests the file PR0801ENG.

Troubleshooting

This chapter describes some common problems that may occur when using the InfoServer. Each section describes possible causes of the problem and lists the corrective steps to take. You may also want to the host client's documentation set for information on accessing the InfoServer.

For more information on troubleshooting the installation of an InfoServer, refer to the *InfoServer 100 Installation and Owners Guide*.

5.1 Cannot Connect to the InfoServer Disk

If you cannot connect to a virtual disk being served by the InfoServer, the InfoServer may be configured incorrectly. In this case, an operating system error appears when you use the proper client commands to connect to a virtual disk. This section describes some of the possible problems and the corrective steps to take if you observe this symptom.

Possible Problem:

The compact disc that you are trying to connect to has been removed from the InfoServer.

Corrective Steps:

- 1 Determine if the compact disc has been removed from the InfoServer. Log in to either the local or remote LAT management console, then issue the SHOW DEVICE command. The column at the far right lists the volume label for all devices listed. If the volume label of the compact disc you are trying to connect to is not

listed, then the compact disc has probably been removed from the InfoServer.

- ② If the compact disc has been removed, reinsert it into a free InfoServer drive. Then enter the SHOW DEVICE command again and check to see if the volume label of the compact disc is listed.
- ③ When the volume label appears, you should be able to connect to the compact disc from your client system.

Possible Problem:

The InfoServer, client system, or both are physically disconnected from the LAN network; or, they are attached to different networks.

Corrective Steps:

- ① Determine if the client and server are not on the same LAN network. From the client system, enter the command to invoke the MOP LOOP function. For example, on an MS-DOS system with DECnet:

```
A:\> NCP LOOP CIRCUIT PHYSICAL-ADDRESS 08-00-2B-15-00-9F
LOOP CIRCUIT test started at 13-Aug-1990 11:49:17
Sending loop message 1, 46.
Message echoed by remote circuit loopback 1, 46 bytes.

LOOP CIRCUIT test finished successfully at 13-Aug-1990 11:49:17
A:\>
```

- ② If the MOP LOOP function fails, then the client and InfoServer are not able to communicate. One or both systems are probably not attached to the same LAN network correctly.
- ③ Some client systems may also provide the ability to list servers on the LAN network. For example, on VMS you can enter the command:

```
$ MCR ESS$LASTCP
%LASTCP-I-VERSION, LASTDRIVER X1.5 is running
LASTCP> SHO SERVERS
```

Node Name	Node Id	Physical Address	Active Links	Start Time
LAD_08002B1605E6	08002B1605E6-3037	08-00-2B-16-05-E6	0	-

If the InfoServer you are trying to connect to is not listed, then the client system and InfoServer are probably not connected to the same LAN network.

- ④ If this is the problem, connect the client and InfoServer to the same LAN network. Inspect the Ethernet connections for both systems to make sure they are properly connected.

Possible Problem:

There is a filtering device between your InfoServer and client system that does not allow the LAST protocol or multicast address through.

Corrective Steps:

- ① The steps to correct this problem depend on the filtering device that is between the client and the InfoServer. For example, the filtering device may be an Ethernet bridge.
- ② Enter the appropriate management commands to the filtering device to determine if the LAST protocol type is being filtered. The protocol type 80-41 must be allowed across the device for clients and InfoServers to communicate,.
- ③ Enter the appropriate management commands to the filtering device to determine if the LAST multicast address is being filtered. The multicast address must be allowed across the filtering device for clients and InfoServers to communicate. The address is 09-00-2B-04-*xx-xx*, where *xx-xx* is the hexadecimal value of the work group that has been set for the InfoServer)
- ④ If either the protocol type or multicast address are being filtered, enter the appropriate management commands to the filtering device to allow the LAST protocol type and multicast address to pass unfiltered. This should allow client systems to connect to the InfoServer.

Possible Problem:

The InfoServer has run out of local memory resources to complete new connections to disks.

Corrective Steps:

- ① Determine if the InfoServer has run out of memory. Log in to either the local or remote LAT management console, then enter the SHOW SERVER command. If the *% of Pool Free* value is below 5 percent, then the server may not have enough memory to establish new connections.
- ② If the server does not have enough memory, the corrective action depends on how the InfoServer is using memory. If the InfoServer is offering many unused services to the LAN network, you may have to delete some services.
- ③ If the server is performing many concurrent downline loads, then it may not be able to accept new connections. You can disable the MOP downline load function with the SET SERVER MOP DISABLED command.
- ④ If there are more than 100 connections to virtual disks listed in the *Current Sessions* field of the SHOW SERVER command, then the capacity of the InfoServer may be exceeded. You must distribute your LAN network connections among other available InfoServers on the LAN network.

One way to distribute connections is to put different InfoServers and clients into different *work groups*. See the SET SERVER WORK GROUP commands (Chapter 3) and the appropriate client system documentation for the client syntax for changing work groups.

Possible Problem:

The requested service name for the virtual disk has not been served on the InfoServer.

Corrective Steps:

- ① Determine if the requested service name is being served by the InfoServer. Connect to either the local or remote management console, then enter the SHOW SERVICE * command. If the service name being requested is not listed, the InfoServer is not offering the requested service.

- ② If the InfoServer is not offering the requested service, enter the InfoServer CREATE SERVICE command to make the device or partition you wish to connect to available under the proper service name. See the SET SERVER WORK GROUP command (Chapter 3).
- ③ You may wish to save the created service with the SAVE command, so the service is always available whenever the InfoServer reboots.

Possible Problem:

The InfoServer and client system belong to different work groups.

Corrective Steps:

- ① Determine if the InfoServer and client system belong to different work groups. Connect to either the local or remote management console, then enter the SHOW SERVER command. Check the *Work Group* field for the group that the InfoServer belongs to.
- ② Enter the appropriate command on the client system to determine the group that the client system belongs to. For example, on VMS:

```
$ MCR ESS$LASTCP
LASTCP> SHOW STATUS
Status of LASTDRIVER X1.5 on node SAUL at 28-JUL-1990 12:16:41
Protocol version 3.1, Uptime: 5 04:09:48.03, Checksum Off,
Slow mode Off

25306 Bytes pool
  8 Ethernet buffers
  0 I/O request packets
  0 Association control blocks
  0 Local session control blocks
  0 LSC In-Use blocks
  0 Transaction control blocks
  2 Circuit status blocks
44 Node data blocks
  5 Transmit quota
80 Maximum circuits
  0 LAN group code
  0 Server circuit timeout
```

In this example, the *LAN group code* field lists the work group of the client system as 0.

- ③ Enter the appropriate InfoServer or client system command to put both systems into the same work group. See the SET SERVER WORK GROUP command (Chapter 3).

Possible Problem:

The requested service name is protected by a password on the InfoServer, and the client system has not supplied the correct password.

Corrective Steps:

- ① Determine if the InfoServer service has a password. Connect to either the local or remote management console, then enter the SHOW SERVICE *service_name* command, where *service_name* is the name of the service you are trying to connect to. Check the *Password:* field to see if password protection is enabled or disabled.
- ② If the service has password protection, then either disable the password by using the SET SERVER command (Chapter 3) or specify the correct password on the client system. Try to make the connection again.

Possible Problem:

There is a read/write conflict in accessing the requested virtual disk. If there is a write-access session to a virtual disk, the InfoServer will not allow new read sessions and read/write sessions.

Corrective Steps:

- ① Determine if there is read/write conflict accessing the virtual disk. Connect to either the local or remote management console, and enter the SHOW DEVICE DK*n*: command, where DK*n*: is the device that you are trying to connect to. This display lists all services offered for that device.
- ② For each service name being offered for the device, enter the SHOW SERVICE *service_name* FULL command. This display lists the number of readers and writers connected to each system. See Section 2.7 for the different read/write policies used by the InfoServer.

- ③ If there is a read/write conflict to the service, you can do one of the following:
- Wait until the conflicting connection is disconnected by the other client system.
 - Delete write access to the conflicting service from the InfoServer management console.
 - Delete the conflicting service from the InfoServer.

Then try connect to the InfoServer service again.

Possible Problem:

The service name for the virtual disk that you are trying to access is in the wrong or different name space.

Corrective Steps:

- ① Determine the service class under which the service you are requesting is being offered. Connect to either the local or remote management console, then enter the `SHOW SERVICE service_name` command. *service_name* is the name of the service you are trying to connect to. The display lists the service class in square brackets (`[]`) after the service name.
- ② If the service is not offered under the service class for the client system you are trying to connect from, then create the same service name under the appropriate name space. See the `SET SERVER WORK GROUP` command (Chapter 3).

Possible Problem:

The service name being requested by the client is offered on more than one InfoServer. The client is selecting a different InfoServer than the one intended, and the other InfoServer is not set up correctly to allow client access.

Corrective Steps:

- ① Determine if the service is offered by more than one InfoServer. Connect to either the local or remote management console, then enter the `MONITOR SHOW ETHERNET` command. Watch the

Messages transmitted field under the LAST counters section, while trying to connect from the client system again. If this counter does not increment during the client access attempt, then another InfoServer may be replying to the request.

- ② If another InfoServer offers the same service name, then use the InfoServer CREATE SERVICE command to create a unique service name for the virtual disk or partition you are trying to connect to. Then try to connect from the client system again, using the new service name.

Possible Problem:

The InfoServer has encountered an internal software logic error, preventing access to its disks.

Corrective Steps:

- ① If none of the other corrective actions solve this problem, you may have a software logic problem.
- ② If you have access to the InfoServer hardware unit, examine the eight diagnostic LEDs on the back of the unit. If the software is running properly, these LEDs should turn on in a rotating pattern from right to left. If the LEDs do not display the rotating pattern, the system is hung. Turn the InfoServer off and on to clear the condition, then reboot the software.
- ③ If you cannot recover from the problem, reboot the InfoServer. Then try to make the connection again.
- ④ Please submit a Software Performance Report (SPR), describing in as much detail as possible the problem you experienced, the corrective actions you tried, and the results. Also provide as much information about the client systems as possible.

5.2 Access to InfoServer Disks Seems Slow

Under normal operating conditions, access times for a virtual disk on the InfoServer should be comparable to access times for a locally attached disk. In many cases, accessing compact discs on the InfoServer can actually appear to be substantially faster than a locally attached compact disc, due to the Infoserver's disk-caching policies. If access to virtual disks on the InfoServer appears unusually slow, a problem may exist in your LAN network.

Possible Problem:

The InfoServer is experiencing "system buffer unavailable" errors. If the LAN network load imposed on the InfoServer is too great, the client systems and InfoServer will intentionally decrease their LAN network rates to try to resolve the LAN's network-load problem.

Corrective Steps:

- 1 Determine if the InfoServer is experiencing "system buffer unavailable" errors. Connect to either the local or remote management console, then enter the `SHOW ETHERNET` command.

Check the *System buffer unavailable* counter for a nonzero value. If this counter is not 0 or is incrementing, then the LAN network load may be too high for the InfoServer.

- 2 If the "system buffer unavailable" error is occurring and you are not performing downline loading from the InfoServer, then you may want to enter the `SET SERVER MOP DISABLED` command. If MOP is enabled, a multicast address is enabled that causes the InfoServer to receive messages from the DECnet network that are not intended for the InfoServer. This event is shown by the *Unrecognized Destination* field of the `SHOW ETHERNET` display.

Disabling MOP will disable this multicast filter on the InfoServer and reduce the number of unintended messages received by InfoServer. This may correct the "system buffer unavailable" problem, and speed up access to InfoServer disks.

Possible Problem:

The InfoServer has just rebooted or has had the physical media removed and reinserted. In these cases, the client system may take several seconds to discover the broken connection and reestablish the connection to the InfoServer.

Corrective Steps:

- ❶ Determine if the Server has recently rebooted. Enter the SHOW SERVER command, and inspect the *Uptime* field. The uptime indicates how much time has elapsed since the last reboot.
- ❷ If the server has recently rebooted or the media has been removed and reinserted, you do not have to perform any corrective action. After the client reconnects to the InfoServer, the access-delay problem should disappear.

5.3 Cannot Enter InfoServer Commands from a Local Console

The InfoServer management interface is always available from a local terminal connected to a running InfoServer. This section describes some possible problems and corrective steps if you are unable to enter InfoServer commands from a locally attached terminal.

Possible Problem:

The local terminal is connected to the wrong communication serial MMJ port on the InfoServer.

Corrective Steps:

- ❶ Make sure that the terminal is connected to the serial MMJ port labeled 1 on the back of the InfoServer unit. The InfoServer does not make use of serial MMJ ports 2 and 3.
- ❷ If the terminal is connected to the wrong serial MMJ port, then reconnect it to serial MMJ port 1.

Possible Problem:

The local terminal is not set up correctly to communicate with the InfoServer.

Corrective Steps:

- ❶ Check the attached terminal, and make sure that it is set for:
 - 9600 baud
 - 8 bits, no parity
 - XON/XOFF flow control
- ❷ If the terminal settings are incorrect, fix them. Then try entering your InfoServer commands again.

Possible Problem:

The InfoServer had an internal software logic error, preventing access from the terminal console line.

Corrective Steps:

- ❶ If none of the other corrective actions solve this problem, you may have a software logic problem.
- ❷ If you have access to the InfoServer hardware unit, examine the eight diagnostic LEDs on the rear of the InfoServer unit. If the software is running properly, these LEDs should turn on in a rotating pattern from right to left. If the LEDs do not display this rotating pattern, the system is hung.

To clear the condition, turn the InfoServer off and on. Then reboot the software.
- ❸ If you cannot recover from the problem, reboot the InfoServer. Then try entering your InfoServer commands again.
- ❹ Please submit a Software Performance Report (SPR), describing in as much detail as possible the problem you experienced, the corrective actions you attempted, and the results. Also provide known information about the attached terminal and its setup.

5.4 Cannot Enter InfoServer Commands from a Remote Console

The InfoServer uses the LAT protocol to allow remote terminal access to the InfoServer command set. This remote access is always available when the InfoServer is running. This section describes the possible problems and corrective steps to take if you are unable to enter InfoServer commands from a remote LAT terminal.

Possible Problem:

The InfoServer, terminal server, or both are physically disconnected from the LAN network; or, they are attached to different networks.

Corrective Steps:

- 1 Determine if the InfoServer and terminal server are on the same LAN network. From the terminal server, enter the command to invoke the MOP LOOP function. For example, on a DECserver 200:

```
Local> TEST LOOP 08-00-2B-15-00-9F
```

- 2 If the MOP LOOP function fails, then the terminal server and InfoServer cannot communicate. One or both systems are probably not attached to the same LAN network correctly.
- 3 If this is the problem, connect the terminal server and InfoServer to the same LAN network. Inspect the Ethernet connections for both systems.

Possible Problem:

There is a filtering device between your InfoServer and terminal server that does not allow the LAT protocol or multicast address through.

Corrective Steps:

- 1 The steps to correct this problem depend on the filtering device between the terminal server and the InfoServer. For example, the filtering device may be an Ethernet bridge.

- ② Enter the appropriate management commands to the filtering device to determine if the LAT protocol type is being filtered. The protocol type 60-04 must be allowed across the device for terminal servers and InfoServers to communicate.
- ③ Enter the appropriate management commands to the filtering device to determine if the LAT multicast address is being filtered. The multicast address 09-00-2B-00-00-0F must be allowed across the filtering device for the clients and InfoServers to communicate.
- ④ If either the protocol type or multicast address are being filtered, enter the appropriate management commands to the filtering device to allow the LAT protocol type and multicast address to pass unfiltered. This should allow the terminal server to connect to the InfoServer.

Possible Problem:

The password for the InfoServer that you are trying to connect to has been changed.

Corrective Steps:

- ① If the InfoServer has password protection enabled, the terminal server prompts you for a password to connect to the InfoServer. If the InfoServer does not accept the password you enter, then the InfoServer password may have been changed.
- ② If you are unable to determine the new InfoServer password, you can reset the InfoServer to a known password by following the steps in Section 5.9.

Possible Problem:

The InfoServer has run out of local memory resources to complete new connections to the management interface.

Corrective Steps:

- ① Determine if the InfoServer has run out of memory. Connect to the local console and enter the SHOW SERVER command. If the percentage displayed in the *% of Pool Free* field falls below 5

percent, then the server may not have enough memory to establish new LAT connections.

- ② If the server does not have enough memory, the corrective action depends on how the InfoServer is using memory.
 - If the InfoServer is offering many unused services to the LAN network, then you may have to delete some services.
 - If the server is performing many concurrent downline loads, then it may not be able to accept new connections. You can disable the MOP downline load function by using the SET SERVER MOP DISABLED command.
 - If there are more than 100 connections to virtual disks, then the capacity of the InfoServer may be exceeded. The *Current Sessions* field of the SHOW SERVER command lists the number of connections.

If this is the problem, you will need to distribute your LAN network connections among other available InfoServers on the LAN network. One way to do this is to put different InfoServers and clients into different work groups. See the SET SERVER WORK GROUP command (Chapter 3) and the appropriate client system documentation for the client syntax for changing work groups.

Possible Problem:

The InfoServer and terminal server do not share a common group code.

Corrective Steps:

- ① Determine if the InfoServer and terminal server share common group codes. Connect to either the local or remote management console, then enter the SHOW LAT command. The *Enabled Group Codes* field will list the LAT group codes offered by the InfoServer.
- ② Enter the appropriate command on the terminal server to determine the group codes that your console has access to. For example, on a DECserver 200:

```

Local> SHOW PORT

Port 5:                               Server: LAT_08002B13EDAF
Character Size:                        8           Input Speed:         4800
Flow Control:                          XON        Output Speed:        4800
Parity:                                 None        Modem Control:      Disabled

Access:                                Local       Local Switch:       None
Backwards Switch:                      None       Name:               PORT_5
Break:                                  Local      Session Limit:      4
Forwards Switch:                       None      Type:               Soft

Preferred Service: None

Authorized Groups: 0
(Current) Groups: 0

Enabled Characteristics:

Autobaud, Autoprompt, Broadcast, Input Flow Control,
Loss Notification, Message Codes, Output Flow Control,
Verification

```

In this example, the *(Current) Groups* field of the display lists the group codes that the terminal server port can connect to.

- ③ Enter the appropriate InfoServer or terminal server commands to enable a common group code for the terminal server port and the InfoServer service. See the SET SERVER WORK GROUP command (Chapter 3).

Possible Problem:

The terminal server being used does not offer access to password-protected LAT services.

Corrective Steps:

- ① If the terminal server issues an *invalid password* error message without first prompting you for a password, then the terminal server may not support connections to password-protected services.
- ② Check your terminal server documentation to determine if connections to password-protected services are allowed.
- ③ If connections to password-protected services are not supported, you cannot use that type of terminal server to connect to the remote console. The service to the InfoServer remote management console is always password-protected. Try using another type of terminal server to make the connection.

Possible Problem:

There is more than one InfoServer with the same server name on the extended LAN. You are connecting to the incorrect InfoServer, which does not accept your password.

Corrective Steps:

- 1 Determine if there is more than one InfoServer on the extended LAN with the same name. Most terminal servers keep a count of duplicate names detected on the LAN. For example, you can enter the following command on a DECserver 200 to check an InfoServer named LIBRARY_IS:

```
Local> SHOW NODE LIBRARY_IS COUNTERS
```

```
Node: LIBRARY_IS
```

Seconds Since Zeroed:	451828	Multiple Node Addresses:	253
Messages Received:	316	Duplicates Received:	0
Messages Transmitted:	222	Messages Re-transmitted:	0
Slots Received:	177	Illegal Messages Received:	0
Slots Transmitted:	159	Illegal Slots Received:	0
Bytes Received:	7315	Solicitations Accepted:	0
Bytes Transmitted:	208	Solicitations Rejected:	0

If the *Multiple Node Addresses* field is not 0, then there is more than one InfoServer with the name LIBRARY_IS.

- 2 If there is more than one InfoServer with the same name, connect a local terminal to one of the InfoServers and change its name to a unique name. See the SET SERVER WORK GROUP command (Chapter 3).

Possible Problem:

The InfoServer had an internal software logic error, preventing access to its remote management interface.

Corrective Steps:

- 1 If none of the other corrective actions solve this problem, you may have a software logic problem.

- ② If you have access to the InfoServer hardware unit, examine the eight diagnostic LEDs on the rear of the InfoServer unit. If the software is running properly, these LEDs should turn on in a rotating pattern from right to left. If the LEDs do not display this rotating pattern, the system is hung.

To clear the condition, turn the InfoServer off and on. Then reboot the software.

- ③ If you cannot recover from the problem, reboot the InfoServer. Then try entering your InfoServer commands again.
- ④ Please submit a Software Performance Report (SPR), describing in as much detail as possible the problem you experienced, the corrective actions you attempted, and the results. Also provide any known information about the remote terminal server and its setup.

5.5 InfoServer Software Will Not Boot

Normally the InfoServer will boot from the internal RZ23 read/write disk. Booting from the read/write disk rather than from a compact disc allows you to use any compact discs in any InfoServer drive.

If the internal RZ23 disk becomes corrupted or the default boot configuration is altered, the InfoServer may not boot correctly. This section describes how to recover when the InfoServer software will not boot.

Possible Problem:

The boot flags saved for the InfoServer have been altered.

Corrective Steps:

- ① Connect a local terminal to serial MMJ port 1 on the rear of the InfoServer unit. Make sure the terminal is set to 9600 baud, 8 bits, no parity. You must use a local terminal; remote LAT terminals will not work with this procedure.
- ② Press the halt switch on the rear of the InfoServer unit. The >>> prompt should appear.
- ③ At the >>> prompt, enter the following command:

```
>>> SHOW BOOT
```

The BOOT parameter must be set to DKA200,DKA100. If the SHOW BOOT command displays a different setting, enter the following command:

```
>>> SET BOOT DKA200,DKA100
```

- 4 Enter the following command:

```
>>> SHOW BFLG
```

The BFLG parameter must be set to the hexadecimal value D0000000. If the SHOW BFLG command displays a different setting, enter the following command:

```
>>> SET BFLG D0000000
```

- 5 Enter the following command:

```
>>> SHOW HALT
```

The HALT parameter must be set to 2. If the SHOW HALT command displays a different setting, enter the following command:

```
>>> SET HALT 2
```

- 6 When all booting parameters are set correctly, try to boot the InfoServer software:

```
>>> B
```

Possible Problem:

The system software on the RZ23 disk is corrupted. This could be caused by clients on the LAN network accessing the disk accidentally, or by a disk failure.

Corrective Steps:

- 1 Boot the software from the Infoserver compact disc instead of from the read/write disk. Insert the compact disc supplied with the InfoServer unit into the compact disc drive on the right of the InfoServer unit's front panel. Turn the InfoServer off and on to reboot the unit.
- 2 After booting from the compact disc, enter the following InfoServer command:

```
InfoServer> SHOW PARTITION DK1:
```

- ③ If the `SHOW PARTITION` command succeeds, but the special partition named `BOOT_PARTITION` does not appear, then only the system software has been lost. To recover, enter the following InfoServer commands:

```
InfoServer> SET SERVER STATE OFF
InfoServer> UPDATE SYSTEM DK2: DK1:
InfoServer> SET SERVER STATE ON
```

- ④ If an error occurs on the `SHOW PARTITION` command, then the format of the RZ23 disk has been lost. In this case, you must initialize the disk before the system software is copied, as in the following example:

```
InfoServer> SET SERVER STATE OFF
InfoServer> INITIALIZE DK1:
InfoServer> UPDATE SYSTEM DK2: DK1:
InfoServer> SET SERVER STATE ON
```

Possible Problem:

A hardware failure occurred on the InfoServer.

Corrective Steps:

- ① If none of the other corrective steps in this section solve the problem, then your InfoServer may have a hardware failure.
- ② Call your Digital service representative for assistance in repairing or replacing the InfoServer unit.

5.6 Online Help No Longer Available

If the internal RZ23 read/write disk is partially corrupted, online help may no longer be available. Use the following steps to reinstall online help.

Corrective Steps:

- ❶ Connect to either the local or remote management console on the InfoServer.
- ❷ Insert the compact disc supplied with the InfoServer unit into the compact disc drive on the right of the InfoServer unit's front panel. If a disc is already installed in the drive, remove that disc and reinstall it at the end of this procedure.
- ❸ Enter the following commands to update the system software:

```
InfoServer> SET SERVER STATE OFF
InfoServer> UPDATE SYSTEM DK2: DK1:
InfoServer> SET SERVER STATE ON
```

- ❹ If you removed another compact disc to insert the InfoServer compact disc, reinstall that disc now.

5.7 InfoServer Does Not Boot Completely

If the InfoServer starts to boot but does not display the *Password:* prompt, then the internal RZ23 read/write disk may be corrupted. This section lists the steps to correct this problem.

Possible Problem:

The configuration partition used to store InfoServer parameters, services, and other operational characteristics may be corrupted.

Corrective Steps:

- ❶ Connect a local terminal to serial MMJ port 1 on the rear of the InfoServer unit. Make sure the terminal is set to 9600 baud, 8 bits, no parity. You must use a local terminal; remote LAT terminals will not work with this procedure.
- ❷ Press the halt switch on the rear of the InfoServer unit. The >>> prompt should appear.
- ❸ At the >>> prompt, enter the following command:

```
>>> B/D0000001
```

This command causes the InfoServer software to boot without reading the configuration database from the read/write disk. Therefore, all system defaults are in effect for this boot.

- ④ At the *Enter Password:* prompt, enter the default password ESS.
- ⑤ Reenter the characteristics that you want to save for the InfoServer, then enter the SAVE command. This should correct the corruption of the configuration partition.

Possible Problem:

The InfoServer operational software section of the disk may be partially corrupted.

Corrective Steps:

- ① Boot the software from the Infoserver compact disc instead of from the read/write disk. Insert the compact disc supplied with the InfoServer unit into the compact disc drive on the right of the InfoServer unit's front panel. Turn the InfoServer off and on to reboot the unit.
- ② After booting from the compact disc, enter the following InfoServer command:

```
InfoServer> SHOW PARTITION DK1:
```

- ③ If the SHOW PARTITION command succeeds, but the special partition named BOOT_PARTITION does not appear, then only the system software has been lost. To recover, enter the following InfoServer commands:

```
InfoServer> SET SERVER STATE OFF
InfoServer> UPDATE SYSTEM DK2: DK1:
InfoServer> SET SERVER STATE ON
```

- ④ If an error occurs on the SHOW PARTITION command, then the format of the RZ23 disk has been lost. In this case, you must initialize the disk before the system software is copied, as in the following example:

```
InfoServer> SET SERVER STATE OFF
InfoServer> INITIALIZE DK1:
InfoServer> UPDATE SYSTEM DK2: DK1:
InfoServer> SET SERVER STATE ON
```

Possible Problem:

A hardware failure occurred on the InfoServer.

Corrective Steps:

- ❶ If none of the other corrective steps in this section solve the problem, then your InfoServer may have a hardware failure.
- ❷ Call your Digital service representative for assistance in repairing or replacing the InfoServer unit.

5.8 InfoServer Does Not MOP Downline Load Systems

The InfoServer can automatically downline load systems that request a specific load image by name. If the InfoServer manager has created the proper MOP partition on the InfoServer, downline loading should work. This section describes the possible problems and corrective steps to take if you are unable to downline load a system from an InfoServer.

Possible Problem:

The MOP downline loading feature is disabled on the InfoServer.

Corrective Steps:

- ❶ Determine if MOP downline loading is disabled on the InfoServer. Connect to either the local or remote management console, then enter the SHOW MOP command. If downline loading is disabled, asterisks (*) appear at the bottom of the display.
- ❷ If MOP downline loading is disabled, enter the SET SERVER MOP ENABLED command to reenable downline loading.

Possible Problem:

The InfoServer, the system requesting a downline load, or both are physically disconnected from the LAN network; or, they are attached to different networks.

Corrective Steps:

- ❶ Determine if the InfoServer and system requesting a downline load are on the same LAN network. Most systems cannot issue a MOP LOOP test before they are downline loaded. You will need to

monitor the InfoServer counters to determine if the InfoServer and remote system are not connected.

- ② Connect to either the local or remote management console. Then enter the following commands:

```
InfoServer> ZERO MOP  
InfoServer> MONITOR SHOW MOP
```

Try to downline load from the remote system again. If the remote system still fails to load and none of the MOP counters in the SHOW MOP display increment, then the InfoServer and remote system requesting a downline load are probably not connected to the same LAN network.

- ③ If this is the problem, connect the requesting system and InfoServer to the same LAN network. Inspect the Ethernet connections for both systems.

Possible Problem:

There is a filtering device between your InfoServer and client system that does not allow the LAT protocol or multicast address through.

Corrective Steps:

- ① The steps to correct this problem depend on the filtering device between the client and the InfoServer. For example, the filtering device may be an Ethernet bridge.
- ② Enter the appropriate management commands to the filtering device to determine if the MOP-loading protocol type is being filtered. The protocol type 60-01 must be allowed across the device for requesting systems and InfoServer to communicate.
- ③ Issue the appropriate management commands to the filtering device to determine if the MOP-loading multicast address is being filtered. The multicast address AB-00-00-02-00-00 must be allowed across the filtering device for the requesting system and InfoServer to communicate.
- ④ If either the protocol type or multicast address are being filtered, enter the appropriate management commands to the filtering device to allow the MOP-loading protocol type and multicast address to pass unfiltered. This should allow the requesting system to downline load from the InfoServer.

Possible Problem:

The InfoServer has run out of local memory resources to complete new downline load requests.

Corrective Steps:

- ❶ Determine if the InfoServer has run out of memory. Connect to either the local or remote management console, then enter the `SHOW SERVER` command. If the percentage displayed in the *% of Pool Free* field falls below 5 percent, then the server may not have enough memory to handle new downline load requests.
- ❷ If the server does not have enough memory, the corrective action depends on how the InfoServer is using memory.
 - If the InfoServer is offering many unused services to the LAN network, then you may have to delete some services.
 - If there are more than 100 connections to virtual disks, then the capacity of the InfoServer may be exceeded. The *Current Sessions* field of the `SHOW SERVER` command lists the number of connections.

If this is the problem, you will need to distribute your LAN network connections among other available InfoServers on the LAN network. One way to do this is to put different InfoServers and clients into different work groups. See the `SET SERVER WORK GROUP` command (Chapter 3) and the appropriate client system documentation for the client syntax for changing work groups.

Possible Problem:

The InfoServer is currently processing the maximum number of downline load requests that it can handle.

Corrective Steps:

- ❶ Determine if the maximum number of downline load requests has been exceeded. Connect to either the local or remote management console, then enter the `SHOW MOP` command. If the *Load failed, server limit* counter is not 0, then the InfoServer was handling its limit of downline load requests at some point.

- ② Wait until the InfoServer complete some of the current downline loads and the *Loads in progress* count gets smaller. Then try the downline load operation from the requesting system again.

Possible Problem:

The InfoServer does not contain the downline loadable image requested.

Corrective Steps:

- ① Determine if the InfoServer has the requested downline loadable image installed. Connect to either the local or remote management console, then enter the SHOW MOP command. If the *Load error, file not found* counter increments each time the requesting system attempts a downline load, then the InfoServer does not have the image requested.
- ② See the UPDATE MOP command (Chapter 3) or Section 4.7 for information on installing MOP downline loadable images.
- ③ Use the appropriate command(s) to install the desired downline loadable image. Then try the downline load operation again.

Possible Problem:

The InfoServer partition that contains the requested downline loadable image is not set up as a MOP partition.

Corrective Steps:

- ① Determine whether or not the InfoServer partition is a MOP partition. Connect to either the local or remote management console, then enter the SHOW MOP command. Check if the *Load failed, partition type* count is a value other than 0. If this counter increments each time the remote system tries to downline load, then the partition containing the load image is not set up properly.
- ② Enter the SHOW PARTITION *DKn:image_name* command. *DKn:* is the device holding the image partition, and *image_name* is the name of the requested image. If the partition is listed without a MOP flag after the size field, then the image is not set up to be downline loaded.

- ③ Use the SET PARTITION command to enable the partition to be downline loaded. See the SET SERVER WORK GROUP command (Chapter 3).

Possible Problem:

The downline loadable image in the requested MOP partition was not copied to the server correctly, so the image has an invalid or unrecognized format. Or the image is too large to downline load in the requested manner.

Corrective Steps:

- ① Determine if the InfoServer has a bad load image that it cannot load. Connect to either the local or remote management console, then enter the SHOW MOP command. Check the following error counters for values other than 0.
 - Load failed, not contiguous
 - Load failed, read error
 - Load failed, protocol error
 - Load failed, file too big
 - Load failed, bad file type

If any of these counters increment each time the remote system tries to downline load, then the load image is not installed correctly on the InfoServer.

- ② See the UPDATE MOP command (Chapter 3 or Section 4.7 for information on installing MOP downline loadable images.
- ③ Use the appropriate command(s) to install the desired downline loadable image, then try the downline load operation again.

Possible Problem:

The InfoServer has an internal software logic error that is preventing access to its disks or preventing the server from responding to the load request.

Corrective Steps:

- ❶ If none of the other possible problems and solutions solve your problem, you may have a software logic problem.
- ❷ If you have access to the InfoServer hardware unit, examine the eight diagnostic LEDs on the rear of the InfoServer unit. If the software is running properly, these LEDs should turn on in a rotating pattern from right to left. If the LEDs do not display this rotating pattern, the system is hung.

To clear the condition, turn the InfoServer off and on. Then reboot the software.

- ❸ If you cannot recover from the problem, reboot the InfoServer. Then try the operation again.
- ❹ Please submit a Software Performance Report (SPR), describing in as much detail as possible the problem you experienced, the corrective actions you attempted, and the results. Also provide any known information about the requesting system and its setup.

5.9 Forgot the InfoServer Password

The InfoServer has a default password of ESS, which you can change with InfoServer commands. You must enter the correct password before you can start an InfoServer management session, either locally or remotely. If you forget your InfoServer password, you can reset the InfoServer to its default configuration and password as described in this section.

Corrective Steps:

- ❶ Connect a local terminal to the serial MMJ port 1 on the rear of the InfoServer unit. Make sure the terminal is set to 9600 baud, 8 bits, no parity. You must use a local terminal; remote LAT terminals will not work with this procedure.
- ❷ Press the halt switch on the rear of the InfoServer unit. The >>> prompt should appear.

- 3 At the >>> prompt, enter the following command:

```
>>> B/D0000001
```

This command causes the InfoServer software to boot without reading the configuration database from the read/write disk. Therefore, all system defaults are in effect for this boot.

- 4 At the *Enter Password:* prompt, enter the default password ESS. You now have access to InfoServer commands.
- 5 After you log in, you can restore all of the previous system configuration by using the RESTORE command:

```
InfoServer> RESTORE
%ESS-I-RESTORE, Restoring Configuration from DK1:
InfoServer>
```

- 6 Change the server password to a known value:

```
InfoServer> SET SERVER PASSWORD
_Password: NEW_PASSWORD (not echoed)
_Verification: NEW_PASSWORD (not echoed)
InfoServer>
```

- 7 Save the current settings, including the new password, with the SAVE command:

```
InfoServer> SAVE
%ESS-I-SAVED, Save completed successfully to DK1:
InfoServer>
```

The system is now restored to its previously saved configuration. Your new password is also saved.

Appendix A

InfoServer V1.0 Command Summary

This appendix lists the command syntax for all InfoServer management commands. You can use the appendix as a quick-reference tool. For a complete description of each command, see Chapter 3.

CLEAR

COPY *DKn:[partition_name] DKn:[partition_name]*

CREATE { *PARTITION DKn:partition_name BLOCKS value [MOP {ENABLED | DISABLED}]* }
{ *SERVICE service_name FOR DKn:[partition_name]* { *CLASS class_name*
STATIC_RATING rating
DYNAMIC_RATING
PASSWORD password
READERS readers
WRITERS writers
NOPASSWORD
NOREADERS
NOWRITERS } } }

DELETE { *PARTITION DKn:partition_name*
SERVICE service_name [FOR DKn:[partition_name]] [CLASS class_name] }

EXIT [or LOGOUT]

HELP *[topic] [subtopic...]*

INITIALIZE *DKn:*

LOOP *[infoserver_command]*

MONITOR *[infoserver_command]*

REBOOT $\left[\begin{array}{l} \text{YES} \\ \text{NO} \end{array} \right]$

RESTORE *[DKn:]*

SAVE *[DKn:]*

```

PARTITION DKn:partition MOP {ENABLED | DISABLED}
[SERVER] AUTOMOUNT { ENABLED
                    DISABLED }

[SERVER] GROUP [CODES] { ALL
                       n,n-m } { ENABLED
                                 DISABLED }
[SERVER] IDENTIFICATION "string"
[SERVER] MOP { ENABLED
              DISABLED }
[SERVER] MULTICAST [TIMER] value
[SERVER] NAME server_name
[SERVER] PASSWORD

SET { [SERVER] STATE { ON
                     OFF
                     SHUT }

     [SERVER] WORK [GROUP] value

     [SERVER] WRITE [ACCESS] { SYNCHRONIZED
                              BLOCKING }

SERVICE service_name [FOR DKn:[partition_name]] [CLASS class]
[ STATIC_RATING rating
  DYNAMIC_RATING
  PASSWORD password
  READERS readers
  WRITERS writers
  NOPASSWORD
  NOREADERS
  NOWRITERS ]

```

SHOW {

DEVICE [*DKn:*] [*BRIEF*]

 [*DK*] [*FULL*]

ETHERNET [*COUNTERS*]

LAT [*COUNTERS*]

MOP [*COUNTERS*]

PARTITIONS {

 DKn:[partition_name]

 *DKn:%**

 [*BRIEF*]

 [*FULL*]

 }

SERVER

SERVICE [*service_name* [*BRIEF*]

 [*FULL*]]
 }

UPDATE { *MOP*

 SYSTEM } *DKn: [DKn:]*

ZERO {

 ALL

 ETHERNET

 LAT

 MOP

 SERVER

 } [*COUNTERS*]

Appendix B

Server Messages

This appendix lists all the user messages that the InfoServer may display. The appendix also provides corrective steps for error and warning messages.

The InfoServer displays three different types of messages to the user: error messages, information messages, and warning messages. You can identify each type of message its one-letter prefix. Following the prefix is a reason code and a simple text message explaining the error.

Informational message: %**ESS-I**-*reason, text*
Error message: %**ESS-E**-*reason, text*
Warning message: %**ESS-W**-*reason, text*

Informational messages are positive feedback indicating that the attempted operation succeeded. These messages also tell you about results from the command that might not be obvious.

Error messages indicate that a command failed to execute properly. The message should help you identify and correct the problem. Consult the other chapters in this manual if necessary.

Warning messages indicate that a command was not able to execute due to a server restriction.

B.1 Informational Messages

%ESS-I-COPIED, Copy operation completed successfully.

Explanation: A copy operation completed successfully.

%ESS-I-CREATED, Create partition completed successfully.

Explanation: A partition was created successfully. This can be the result of a COPY or CREATE PARTITION command.

%ESS-I-CREATED, Create service completed successfully.

Explanation: One or more services were created successfully.

%ESS-I-CREATEBOOT, Creating boot partition.

Explanation: The system is creating a new boot partition when starting up. If the system finds that the first read/write device in the system is not an InfoServer device, the system initializes the device and creates a boot partition.

%ESS-I-CREATEDBOOT, Boot partition created successfully.

Explanation: The boot partition has been created.

%ESS-I-DELETED, Delete partition completed successfully.

Explanation: A partition was deleted successfully.

%ESS-I-DELETED, Delete service completed successfully.

Explanation: One or more services were deleted successfully.

%ESS-I-INIT, Initialize completed successfully on DKn:

Explanation: A device was initialized successfully.

%ESS-I-INITSERVER, Reading Server Database from DKn:

Explanation: When the server started up, it found a configuration partition on device DK*n*: and initialized the server from it.

%ESS-I-RESTORED, Restore completed successfully from DKn:

Explanation: A restore operation completed successfully. The message tells you which device the configuration partition was read from.

%ESS-I-**SAVED**, Save operation completed successfully to DKn:

Explanation: A save operation completed successfully. The message tells you which device the configuration partition was written to.

%ESS-I-**SET**, Set operation completed successfully.

Explanation: A SET command completed successfully.

%ESS-I-**UPDATE**, Update operation completed successfully.

Explanation: An update command completed successfully.

B.2 Error Messages

%ESS-E-**BADKEYWORD**, Unrecognized keyword - xxx

Explanation: You entered a keyword xxx that is not part of the InfoServer's command syntax. See Chapter 3 for the correct syntax.

%ESS-E-**BADFORMAT**, Configuration database has been corrupted on DKn:

Explanation: A configuration partition has been corrupted. Delete the partition named CONFIGURATION on the device. Use the COPY command to restore the configuration from another source, or reenter the configuration and enter a SAVE command.

%ESS-E-**BADSTRING**, Error parsing quoted string

Explanation: You entered a quoted string in the incorrect format. The SET SERVER IDENTIFICATION command takes a quoted string as a parameter. See Chapter 3 for more details.

%ESS-E-**BADVALUE**, Value invalid or out of range -

Explanation: You entered a value that is outside the valid range of the command parameter.

%ESS-E-**CREATEFAILED**, Could not create service or partition, xxx

Explanation: A CREATE command failed. Following this message is an error message giving the exact reason the command failed. For example, one reason might be that the device is full.

%ESS-E-DEVICEFULL, Device is full. Partition was not created.

Explanation: An InfoServer device is full. You can use the DELETE PARTITION command to recycle partitions that are no longer needed.

%ESS-E-DUPLNAM, Service name already exists.

Explanation: You tried to create a service name that already exists. For this error to occur, the duplicate service name must be for the same device (or device and partition), in the same service class.

%ESS-E-DUPPARNAME, Partition name is already used.

Explanation: You tried to create a partition on a device with the same name as an existing partition. Please select a different name for the new partition.

%ESS-E-FAILEDBOOT, Boot partition failed to be created.

Explanation: A boot partition (BOOT_PARTITION) failed to be created on a device during an UPDATE SYSTEM command. For example, the device could be full.

%ESS-E-FILENOTFOUND, File not found, file_name

Explanation: An update operation failed to locate the distribution files on the compact disc. Check that the correct compact disc is in the correct drive, then retry the operation.

%ESS-E-INITFAILED, Failed to initialize device DKn:

Explanation: The device cannot be initialized due to a hard failure such as a write error. Following this message is another message with more specific information on the reason for the failure.

%ESS-E-INVALIDPARG, Expecting ascii string

Explanation: You did not enter a string for a parameter that requires a string.

%ESS-E-INVALIDPARG, Expecting numerical value

Explanation: You did not enter a number for a parameter that requires a numerical value.

%ESS-E-NOHELPPFILE, Failed to locate InfoServer help text.

Explanation: The system cannot find the InfoServer's help file. To restore the help file, see Section 5.6.

%ESS-E-NOHELPPFOUND, Sorry, no documentation on xxx

Explanation: No online help exists for the requested topic. Refer to this guide for help.

%ESS-E-NOPOOL, Insufficient memory available for operation

Explanation: The server's memory is exhausted. This may be a temporary condition that corrects itself, or the server may be overloaded. Try the operation again. If the failure occurs a second time, you can set the server to the off state, perform the operation, and set the server state back on. This should free up enough resources to complete any operation.

%ESS-E-NOSUCHDEV, Device not found.

Explanation: You tried to perform an operation on a device that is not present in the configuration. Use the SHOW DEVICE command to list all devices on the InfoServer.

%ESS-E-NOSUCHSERVICE, Service not found, xxx

Explanation: You tried to set or delete a service xxx that does not exist. The service being accessed may be in a different name space, or you may have misspelled the name.

%ESS-E-NOTESODS, Device does not have InfoServer disk format.

Explanation: You tried an operation that can only be performed on an InfoServer device. InfoServer devices are devices that have been initialized with the INITIALIZE command.

%ESS-E-NOTOFF, Server must be in the OFF state to perform local disk operations.

Explanation: The server state was on when you entered a COPY, INITIALIZATION or UPDATE command. These commands require the server state to be off.

%ESS-E-NOTRWDEV, Can not write to device.

Explanation: A write operation was attempted to a compact disc. One example is the INITIALIZE command.

%ESS-E-ODSVERSION, This InfoServer disk was created with newer software. Please use newer version.

Explanation: An older version of the InfoServer software tries to read a disk that was formatted by a newer version of the software. Always use the newest version of the InfoServer software.

%ESS-E-PARNOTFOUND, Partition not found.

Explanation: You tried to reference a partition that does not exist. The SHOW PARTITIONS command lists all the partitions on a device.

%ESS-E-PARPERM, This partition can not be deleted.

Explanation: You tried to delete a partition that is managed by the server. For example, the BOOT_PARTITION is a partition that cannot be deleted.

%ESS-E-PARMTOOLONG, Parameter supplied was too long.

Explanation: You entered a command parameter string that is longer than the allowed length.

%ESS-E- RESTOREFAILED, Could not restore configuration from DKn:"

Explanation: You tried to restore a configuration, and the operation failed. Following this message is another message giving the exact reason the command failed. For example, one failure might be that the configuration partition was not found.

%ESS-E-SAVEDFAILED, Could not save configuration to DKn:

Explanation: You tried to save the server's configuration to a device that is either not an InfoServer device or not a read/write device. Repeat the command to an InfoServer device.

%ESS-E-SCSIREADERROR, Error Reading disk.

Explanation: The server received an error reading data from a device. Try the operation again. If the error continues, call your field service representative.

%ESS-E-SCSIWRITEERROR, Error writing disk.

Explanation: The server received an error writing data to a device. Try the operation again. If the error continues, call your field service representative.

%ESS-E-SIZEMISMATCH, Source and Destination sizes must be equal.

Explanation: You tried to copy a device or partition to a destination device or partition with a different size. The source and destination device must be the same size.

%ESS-E-UNKNOWNCOMMAND, Unrecognized command.

Explanation: You entered a command that is not part of the InfoServer's command set. See Chapter 3 for the correct syntax.

%ESS-E-VERIFYERR, Verification password failed to match new password.

Explanation: You entered a verification password that does not match a new password. Please repeat the operation.

%ESS-E-WRONGPASSWORD, Invalid password. Please try again.

Explanation: You entered a password that does not match the current server's password. Enter the correct password, or see section Section 5.9 if you can not remember the password.

%ESS-E-WRONGSTATE, Server state must be OFF to perform this operation.

Explanation: You tried a COPY or UPDATE command with the server in the on state. The server state must be off for these commands, to preserve data integrity by limiting access to the server. This prevents remote disk operations from interfering with local disk operations.

B.3 Warning Messages

%ESS-W-NOWRITERS, CD volumes can not be written. Setting maximum writers to zero.

Explanation: You tried to set write access on a compact disc. Compact discs on the InfoServer are read-only.

Index

A

Advanced functions

- assigning multiple service names • 4–3
- assigning passwords to protect compact discs • 4–3
- backing up data
 - locally • 4–7
 - remotely • 4–8
- backing up read/write data • 4–7
- creating and serving partitions • 4–4
- creating MOP partitions for downline loading • 4–9
- serving external read/write disks • 4–6
- serving updated compact discs • 4–2

Automatic service • 1–7

Automount feature • 2–3

Automounting compact discs • 3–28

B

Backing up data

- locally • 4–7
- remotely • 4–8

Backing up read/write data • 4–7

Booting the system

- troubleshooting • 5–17
 - partial boot • 5–20
- updating software • 3–72

Buses • 2–7

C

Central databases

- nightly updates • 3–38

Classes • 3–41

Class names • 3–9

CLEAR command • 3–4

Commands • 3–1

CLEAR • 3–4

COPY • 3–5

CREATE PARTITION • 3–7

CREATE SERVICE • 3–9

DELETE PARTITION • 3–13

DELETE SERVICE • 3–14

EXIT • 3–17

HELP • 3–18

INITIALIZE • 3–19

LOOP • 3–20

MONITOR • 3–21

overview • 1–6

REBOOT • 3–22

repeating • 3–20, 3–21

RESTORE • 3–23

SAVE • 3–25

SET PARTITION • 3–27

SET SERVER AUTOMOUNT • 3–28

SET SERVER GROUP CODES • 3–29

SET SERVER IDENTIFICATION • 3–31

SET SERVER MOP • 3–32

SET SERVER MULTICAST • 3–33

SET SERVER NAME • 3–34

SET SERVER PASSWORD • 3–35

SET SERVER STATE • 3–36

SET SERVER WORK GROUP • 3–37

Commands (Cont.)

- SET SERVER WRITE ACCESS • 3–38
- SET SERVICE • 3–40
- SHOW DEVICE • 3–44
- SHOW ETHERNET • 3–47
- SHOW LAT • 3–52
- SHOW MOP • 3–56
- SHOW PARTITIONS • 3–60
- SHOW SERVER • 3–63
- SHOW SERVICE • 3–66
- UPDATE MOP • 3–70
- UPDATE SYSTEM • 3–72
- ZERO ALL • 3–74
- ZERO ETHERNET • 3–75
- ZERO LAT • 3–76
- ZERO MOP • 3–77
- ZERO SERVER • 3–78

Compact discs

- assigning multiple service names • 4–3
- automatic mounting of • 2–3
- automounting • 3–28
- creating services for special volume labels • 2–6
- external
 - creating services for • 4–6
- formats for automatic serving • 1–2
- serving to different operating systems • 4–3
- serving updated compact discs • 4–2

Connections

- local • 1–4
- remote • 1–4

Console terminal • 1–4

- clearing the screen • 3–4
- local
 - troubleshooting access to • 5–10
- remote
 - troubleshooting access to • 5–12

Conventions

- used in this guide • x

COPY command • 3–5

Counters

- resetting
 - Ethernet • 3–75
 - InfoServer • 3–74
 - MOP • 3–77
 - server • 3–78

CREATE PARTITION command • 3–7

CREATE SERVICE command • 3–9

Creating

Creating (Cont.)

- MOP partitions for downline loading • 4–9
- partitions • 4–4

D

DELETE PARTITION command • 3–13

DELETE SERVICE command • 3–14

Device names • 2–7

Devices

- automatic serving of • 1–7
- displaying device information • 3–45
- SHOW DEVICE command • 3–44

Disks

- formatting • 3–19
- nightly updates • 3–38
- partitions • 2–4
- RZ23 read/write disk • 2–3
- write access • 3–38

Downline loading • 2–11

- displaying errors and counters • 3–57
- feature • 1–2
- partitions for • 4–9
- SET SERVER MOP command • 3–32
- troubleshooting • 5–22
- updating downline loadable images • 3–70

E

Error messages • B–3 to B–7

Errors

- Ethernet • 3–48
- LAST protocol • 3–48
- LAT protocol • 3–53
- MOP protocol • 3–56, 3–57

Ethernet

- displaying errors and counters • 3–48

EXIT command • 3–17

External read/write disk • 4–6

F

Fail over • 1–8

G

Group codes
specifying • 3–29

H

Help
problems with online help • 5–19
HELP command • 1–7, 3–18

I

Identification string for server • 3–31
Informational messages • B–2 to B–3
InfoServer
assigning a name • 2–6
availability • 1–8
commands • 3–1
displaying system information and counters • 3–63
identification • 3–31
major functions • 1–2
messages • B–1
name
SET SERVER NAME command • 3–34
overview • 1–1
password
SET SERVER PASSWORD command • 3–35
relationship to client systems • 1–3
service name • 1–5
state
SET SERVER STATE command • 3–36
updating software • 3–72
work groups • 3–37
InfoServer password • 1–5
INITIALIZE command • 3–19

L

Labels • 2–3
LAD protocol • 2–1
LAN networks
downline loads useful for • 2–11
LAST protocol • 2–1
displaying errors and counters • 3–48

LAT group codes • 3–29
LAT protocol
counters
resetting • 3–76
displaying errors and counters • 3–53
displaying InfoServer characteristics • 3–53
identifying InfoServers • 3–31
LAT server • 1–4
Load balancing • 2–2, 2–4
LOOP command • 3–20
Loop messages • 2–11

M

Managing the server
starting a session • 1–4
Messages • B–1 to B–8
error • B–3 to B–7
format • B–1
informational • B–2 to B–3
types of messages • B–1
warning • B–8
MONITOR command • 3–21
MOP
See also Protocols
downline loading • 2–11
identity requests • 2–11
loop messages • 2–11
read counters • 2–11
MOP protocol
displaying errors and counters • 3–56, 3–57
downline loadable images
updating • 3–70
downline loading
partitions for • 4–9
SET SERVER MOP command • 3–32
troubleshooting • 5–22
Mounting
compact discs • 2–3
MS-DOS
class names • 3–41
Multicast address feature • 2–2
Multicast timer
SET SERVER MULTICAST command • 3–33

N

Names • 2–5 to 2–8
 device • 2–7
 InfoServer • 2–5
 partition • 2–7
 service • 2–6
NCP LOOP CIRCUIT command • 2–11
Nightly updates • 3–38

O

Online help • 3–18
 not available • 5–19
Operating systems
 serving discs to • 4–3

P

Partitions • 1–2
 creating • 4–4
 deleting • 3–13
 displaying information on • 3–60
 for downline loading • 4–9
 MOP • 2–12
 names • 2–6, 2–7
 serving • 4–4
Passwords
 forgetting • 5–27
 InfoServer • 1–5
 setting • 3–35
 protecting compact discs • 4–3
Protocols
 LAD • 2–1
 LAST • 2–1, 2–2
 MOP • 2–10 to 2–12

R

Read counters • 2–11
Read/write access • 2–9
Read/write disks
 backing up data
 locally • 4–7
 remotely • 4–8

Read/write disks (Cont.)

 backing up data from • 4–7
 creating partitions on • 4–4
 external
 creating services for • 4–6
 functions • 2–3
 partitions • 1–2
REBOOT command • 3–22
Removing media
 service disconnection • 1–7
Repeating commands • 3–20
Resetting counters
 Ethernet • 3–75
 InfoServer • 3–74
 LAT • 3–76
 MOP • 3–77
 server • 3–78
RESTORE command • 3–23
RZ23 read/write disk • 2–3

S

SAVE command • 3–25
SCSI
 buses • 2–7
Server management session
 ending • 1–6
Service classes • 2–9
Service names • 2–6
Service ratings • 2–4, 3–10
Services
 deleted with partitions • 3–13
 deleting • 3–14
 displaying information on • 3–66
 modifying attributes • 3–40
 names
 default name • 1–5
 redundant • 2–7
 work groups for • 3–37
Sessions
 ending • 3–17
SET PARTITION command • 3–27
SET SERVER AUTOMOUNT command • 3–28
SET SERVER GROUP CODES command • 3–29
SET SERVER IDENTIFICATION command • 3–31
SET SERVER MOP command • 3–32
SET SERVER MULTICAST command • 3–33

SET SERVER NAME command • 3-34
SET SERVER PASSWORD command • 3-35
SET SERVER STATE command • 3-36
SET SERVER WORK GROUP command • 3-37
SET SERVER WRITE ACCESS command • 3-38
SET SERVICE command • 3-40
SHOW DEVICE command • 3-44
 to determine volume labels • 2-3
SHOW ETHERNET command • 3-47
SHOW LAT command • 3-52
SHOW MOP command • 3-56
SHOW PARTITIONS command • 3-60
SHOW SERVER command • 3-63
SHOW SERVICE
 display fields • 3-68
SHOW SERVICE command • 3-66
Software
 problems • 5-17
Starting a session • 1-4
System
 messages • B-1
 updating downline loadable images
 preserving data • 3-70
 updating software • 3-72
 preserving data • 3-72
System state
 saving • 3-25

T

Terminal
 See Console terminal
TEST LOOP command • 2-11
Transport • 2-2
Troubleshooting • 5-1 to 5-28
 See also the *InfoServer 100 Installation and Owner's Guide*
 cannot connect to the InfoServer disk • 5-1
 entering InfoServer commands
 local console • 5-10
 remote console • 5-12
 forgotten InfoServer password • 5-27
 InfoServer does not downline load systems • 5-22
 InfoServer software does not boot • 5-17

online help not available • 5-19
partial boot • 5-20
slow access to InfoServer disks • 5-9

U

ULTRIX
 service names • 2-9, 3-9
UPDATE MOP command • 3-70
UPDATE SYSTEM command • 3-72

V

VAX systems
 downline loading • 1-2
Virtual disks
 slow access • 5-9
 troubleshooting connections to • 5-1
Virtual disk server, described • 1-1
VMS
 and downline loading • 1-2
 ODS-2 service names • 2-9, 3-9
VMS clients
 quick access to duplicate services • 1-8
Volume labels • 2-3
 determining • 2-3

W

Warning messages • B-8
Work groups
 assigning numbers to • 3-37
Write access • 3-38

Z

ZERO ALL command • 3-74
ZERO ETHERNET command • 3-75
ZERO LAT command • 3-76
ZERO MOP command • 3-77
ZERO SERVER command • 3-78

