

# FDDI Modular Media Interface Cards

---

## Installation

Part Number: EK-FDDIM-IM. A01

**July 1997**

This manual describes how to install and verify the operation of the FDDI Modular Media Interface (Mod-FDDI) cards.

**Revision/Update Information:** This is a new document.

Digital Equipment Corporation makes no representations that the use of its products in the manner described in this publication will not infringe on existing or future patent rights, nor do the descriptions contained in this publication imply the granting of licenses to make, use, or sell equipment or software in accordance with the description.

Possession, use, or copying of the software described in this publication is authorized only pursuant to a valid written license from DIGITAL or an authorized sublicensor.

© Digital Equipment Corporation 1997. All rights reserved. Printed in U.S.A.

The following are trademarks of Digital Equipment Corporation: clearVISN, the clearVISN logo, DEC, DECconnect, DEChub, DECnet, DIGITAL and the DIGITAL logo.

All other trademarks and registered trademarks are the property of their respective holders.

**FCC Notice** — Class A Computing Device:

This equipment generates, uses, and may emit radio frequency energy. The equipment has been type tested and found to comply with the limits for a Class A digital device pursuant to Part 15 of FCC rules, which are designed to provide reasonable protection against such radio frequency interference.

Operation of this equipment in a residential area may cause interference in which case the user at his own expense will be required to take whatever measures may be required to correct the interference. Any modifications to this device - unless expressly approved by the manufacturer - can void the user's authority to operate this equipment under part 15 of the FCC rules.

**VCCI Notice** — Class 1 Computing Device:

This equipment is in the 1st Class category (information equipment to be used in commercial and/or industrial areas) and conforms to the standards set by the Voluntary Control Council for Interference by Data Processing Equipment and Electronic Office Machines aimed at preventing radio interference in commercial and/or industrial areas. Consequently, when used in a residential area or in an adjacent area thereto, radio interference may be caused to radios and TV receivers. Read the instructions for correct handling.

**CE Notice** — Class A Computing Device:

**Warning!**

This is a Class A product. In a domestic environment, this product may cause radio interference, in which case the user may be required to take adequate measures.

**Achtung!**

Dieses ist ein Gerät der Funkstörgrenzwertklasse A. In Wohnbereichen können bei Betrieb dieses Gerätes Rundfunkstörungen auftreten, in welchen Fällen der Benutzer für entsprechende Gegenmaßnahmen verantwortlich ist.

**Avertissement!**

Cet appareil est un appareil de Classe A. Dans un environnement résidentiel cet appareil peut provoquer des brouillages radioélectriques. Dans ce cas, il peut être demandé à l'utilisateur de prendre les mesures appropriées.

# Contents

---

## Preface

Overview .....	vii
Purpose of This Manual .....	vii
Intended Audience .....	vii
Organization .....	viii
Terms .....	ix
Terms Used in This Manual .....	ix
Associated Documents .....	x
Correspondence .....	xi
Documentation Comments .....	xi
Online Services .....	xi
How to Order Additional Documentation .....	xii

## Safety

Overview .....	xiii
Precautions .....	xiv

## 1 FDDI Modular Media Interface Cards

Overview .....	1-1
Introduction .....	1-1
In This Chapter .....	1-1
Introduction .....	1-2
Multimode and Single-Mode Mod-FDDI Cards .....	1-3
UTP Mod-FDDI Cards .....	1-4
Hot-Swap Support .....	1-5

## 2 Installing the Card

Overview . . . . .	2-1
Introduction . . . . .	2-1
In This Chapter. . . . .	2-1
Installation Preparation . . . . .	2-2
Required Tools . . . . .	2-2
Preparing a Host Module. . . . .	2-3
Removing the Slot Cover . . . . .	2-4
Installing the Card . . . . .	2-5
Removing the Card . . . . .	2-7

## 3 Connecting and Removing Cables

Overview . . . . .	3-1
Introduction . . . . .	3-1
In This Chapter. . . . .	3-1
Connecting the Multimode or Single-Mode Fiber-Optic Cables . . . . .	3-2
Removing the Multimode or Single-Mode Fiber-Optic Cables . . . . .	3-4
Connecting the FDDI UTP Cable . . . . .	3-5
Removing the FDDI UTP Cable . . . . .	3-6

## 4 Using the Card

Overview . . . . .	4-1
Introduction . . . . .	4-1
In This Chapter. . . . .	4-1
Initializing the Card. . . . .	4-2
Verifying Operability . . . . .	4-4
LED Conditions. . . . .	4-5
Performing a Loopback Test. . . . .	4-6
Checking the Connections . . . . .	4-6
Connecting a FDDI UTP Loopback Connector . . . . .	4-7
Connecting a Multimode or Single-Mode Fiber-Optic Loopback Connector . . . . .	4-8
If the Loopback Test Passes . . . . .	4-9

## A Cable and Connector Information

Overview . . . . .	A-1
In This Appendix . . . . .	A-1
Multimode Fiber-Optic Cable and Connector Information. . . . .	A-2

Multimode and Single-Mode Cable Specifications . . . . .	A-4
Multimode Fiber-Optic Cable Specifications . . . . .	A-4
Single-Mode Fiber-Optic Cable Specification . . . . .	A-4
FDDI UTP Cable and Connector Information . . . . .	A-6
FDDI UTP Cable Specifications . . . . .	A-7
8-Pin MJ Connector . . . . .	A-7

## Figures

1-1 Multimode or Single-Mode Mod-FDDI Card Components . . . . .	1-3
1-2 UTP Mod-FDDI Card Components . . . . .	1-4
2-1 Removing the Slot Cover . . . . .	2-5
2-2 Installing the Card . . . . .	2-7
2-3 Removing the Card . . . . .	2-9
3-1 Connecting the Multimode and Single-Mode Fiber-Optic Cables . . . . .	3-3
3-2 Removing the Multimode or Single-Mode Fiber-Optic Cables . . . . .	3-4
3-3 Connecting the FDDI UTP Cables . . . . .	3-5
3-4 Removing the FDDI UTP Cable . . . . .	3-6
4-1 FDDI UTP Loopback Connector . . . . .	4-7
4-2 Connecting a Multimode Fiber-Optic Loopback Connector . . . . .	4-8
A-1 Multimode Fiber-Optic Cables . . . . .	A-3
A-2 Multimode Fiber-Optic Loopback Connector . . . . .	A-3
A-3 FDDI UTP Cable . . . . .	A-6
A-4 FDDI UTP Loopback Connector . . . . .	A-6
A-5 8-Pin MJ Connector . . . . .	A-7

## Tables

4-1 LED Conditions . . . . .	4-5
A-1 8-Pin MJ Pin Assignments . . . . .	A-7



---

# Preface

---

## Overview

### Purpose of This Manual

This manual describes how to install the FDDI Modular Media Interface (Mod-FDDI) cards and how to verify their installation and operation.

### Intended Audience

This manual is intended for the user who has experience with installing system hardware.

## Organization

This manual is organized as follows:

<b>Section</b>	<b>Description</b>
Chapter 1	Provides a description of the FDDI Modular Media Interface (Mod-FDDI) cards.
Chapter 2	Describes how to install the modular media interface card.
Chapter 3	Contains media connection information.
Chapter 4	Contains operation and initialization information.
Appendix A	Contains cable specifications for each media type.



---

## Terms

### Terms Used in This Manual

This book uses the following terms:

---

<b>Term</b>	<b>Definition</b>
FDDI	Fiber Distributed Data Interface, a set of industry standards for high-speed fiber-optic ring local area networks
Mod-FDDI	FDDI Modular Media Interface, front-insertable, hot-swappable, single-slot option interface cards
UTP	Unshielded, twisted-pair cable with no metal shielding around the conductors

---

---

## Associated Documents

The following documents provide information relating to the FDDI Modular Media Interface cards. To order any of the following documents, refer to the direction in the section titled, How to Order Additional Documentation.

<b>Title and Order Number</b>	<b>Description</b>
<i>VNswitch 900EF Installation and Configuration</i> EK-DVNEF-IN	Provides installation and configuration information for the VNswitch 900EF module.
<i>VNswitch 900FA Installation and Configuration</i> EK-DVNFA-IN	Provides installation and configuration information for the VNswitch 900FA module.
<i>VNswitch 900 Series Technical Overview</i>	Provides a technical overview of the VNswitch 900 family of high-density switching products.
<i>VNswitch 900 Series Switch Management</i>	Describes how to configure, monitor, and manage a VNswitch 900 series module.
<i>OPEN DECconnect Applications Guide</i> EC-G2570-42	Provides information to help plan and install networking systems based on the DIGITAL OPEN DECconnect System and networking products.
<i>clearVISN Installation</i>	Provides pre- and post-installation information, as well as actual installation procedures for each application.
<i>clearVISN Overview</i>	Provides an overview of the clearVISN software, an explanation of each application, and descriptions of all concepts necessary to understand and use the application efficiently.
<i>clearVISN User's Guide</i>	Provides information for starting each application, configuring them and general use information.
<i>CCITT Recommendation I.432, B-ISDN UNI-Physical Interface Specification</i>	Provides information on implemented standards.

---

## Correspondence

### Documentation Comments

If you have comments or suggestions about this document, send them to the Network Products Business Organization.

Attn: Documentation Project Manager  
FAX: (508) 486-6093  
E-MAIL: doc\_feedback@lkg.mts.dec.com

### Online Services

To locate product-specific information, refer to the following online services:

#### BBS

To read the Bulletin Board System, set your modem to 8 bits, no parity, 1 stop bit and dial 508-486-5777 (U.S.).

#### WWW

The Digital Equipment Corporation Network Products Business Home Page on the World Wide Web is located at the following addresses:

**North America:** <http://www.networks.digital.com>

**Europe:** <http://www.networks.europe.digital.com>

**Australia:** <http://www.digital.com.au/networks>

## How to Order Additional Documentation

To order additional documentation, use the following information:

---

<b>To Order:</b>	<b>Contact:</b>
By Telephone	Continental U.S.A.: 1-800-DIGITAL (1-800-344-4825) Canada: 1-800-267-6215 Alaska, New Hampshire, and Hawaii: 1-603-884-6660
Electronically (U.S.A. only)	Dial 1-800-DEC-DEMO (For assistance, call 1-800-DIGITAL)
By Mail (U.S.A. and Puerto Rico)	DIGITAL EQUIPMENT CORPORATION P.O. Box CS2008 Nashua, New Hampshire 03061 (Place prepaid orders from Puerto Rico with the local DIGITAL subsidiary: 809-754-7575)
By Mail (Canada)	DIGITAL EQUIPMENT CORPORATION LTD. 940 Belfast Road Ottawa, Ontario, Canada K1G 4C2 Attn: A&SG Business Manager
Internationally	DIGITAL EQUIPMENT CORPORATION A&SG Business Manager c/o local DIGITAL subsidiary or approved distributor
Internally	U.S. Software Supply Business (SSB) DIGITAL EQUIPMENT CORPORATION 8 Cotton Road Nashua, New Hampshire 03063

---

---

# Safety

---

## Overview

The cautions that must be observed for the hardware described in this manual are listed in this section in English, German, French, and Spanish. Any warning or caution that appears in this manual is defined as follows:

<b>WARNING</b>	Contains information to prevent personal injury.
<b>CAUTION</b>	Contains information to prevent damage to equipment.
<b>VORSICHT</b>	Enthält Informationen, die beachtet werden müssen um den Benutzer vor Schaden zu bewahren.
<b>ACHTUNG</b>	Enthält Informationen, die beachtet werden müssen um die Geräte vor Schaden zu bewahren.
<b>DANGER</b>	Signale les informations destinées à prévenir les accidents corporels.
<b>ATTENTION</b>	Signale les informations destinées à prévenir la détérioration du matériel.
<b>AVISO</b>	Contiene información para evitar daños personales.
<b>PRECAUCIÓN</b>	Contiene información para evitar daños al equipo.

## Precautions

---

<b>WARNING</b>	Some fiber-optic equipment can emit laser or infrared light that can injure your eyes. Never look into an optical fiber or connector port. Always assume the cable is connected to a light source.
<b>VORSICHT</b>	Bestimmte Lichtleitergeräte können für die Augen gefährliches Laser- oder Infrarotlicht abstrahlen. Vermeiden Sie es daher unter allen Umständen, direkt in ein Lichtleiterkabel oder einen Lichtleiteranschluß zu schauen. Gehen Sie immer davon aus, daß Lichtleiterkabel mit einer Lichtquelle verbunden sind.
<b>DANGER</b>	Certains équipements à fibre optique peuvent émettre un rayonnement laser ou infra-rouge pouvant provoquer des troubles oculaires. Ne regardez jamais à l'intérieur d'une fibre optique ou d'un port de connecteur. Considérez que le câble est connecté en permanence à une source lumineuse.
<b>AVISO</b>	Ciertos equipos de fibras ópticas pueden emitir luz láserica o infrarroja con riesgos de lesiones en los ojos. No se debe nunca mirar en una fibra óptica o una puerta de conexión. Siempre hay que suponer que el cable está conectado a una fuente luminosa.

---

## Precautions

---

<b>CAUTION</b>	Static electricity can damage modules and electronic components. DIGITAL recommends using a grounded antistatic wrist strap and a grounded work surface when handling any modules.
<b>ACHTUNG</b>	Module und elektronische Komponenten können durch elektrostatische Entladungen beschädigt werden. Benutzen Sie immer eine antistatische Gelenkmanschette und eine geerdete Arbeitsunterlage, wenn Sie am offenen Gerät arbeiten.
<b>ATTENTION</b>	Les charges excessives d'électricité statique peuvent endommager les modules et les composants électroniques. DIGITAL conseille l'utilisation d'un bracelet de masse et d'un plan de travail mis à la terre lors de la manipulation des modules.
<b>PRECAUCION</b>	La electricidad estática puede dañar los componentes electrónicos y los módulos. DIGITAL recomienda que se utilicen cintas de pasadores y superficies de trabajo conectadas a tierra al trabajar con cualquier módulo.

---





# Chapter 1

---

## FDDI Modular Media Interface Cards

---

### Overview

#### Introduction

This chapter describes the two types of Fiber Distributed Data Interface (FDDI) Modular Media Interface (Mod-FDDI) cards.

#### In This Chapter

Topic	Page
Introduction	1-2
Hot-Swap Support	1-5

## Introduction

The FDDI Modular Media Interfaces (Mod-FDDI) are part of the Modular Media Interface family of front insertable, hot swappable, single-slot option cards. They are customer installable and field replaceable. The host module provides the power, initialization, and control for the card.

---

### NOTE

Asynchronous Transfer Mode (ATM) Modular PHY (modPHY) cards, 100 Mb/s Fast Ethernet Modular Media Interface (MM-100) cards, and Mod-FDDI cards are NOT interchangeable.

---

Attachment and removal of these cards depends on the type of physical media interface that the cards use. For more media connection information, refer to Chapter 3.

---

### CAUTION

Static electricity can damage modules and electronic components. DIGITAL recommends using a grounded antistatic wrist strap and a grounded work surface when handling any modules.

---

Figure 1-1 and Figure 1-2 show examples of the FDDI modular media interface cards discussed in this manual.

## Multimode and Single-Mode Mod-FDDI Cards

The multimode (DEFYM-AA) and single-mode (DEFYS-AA) Mod-FDDI cards allow the connection of FDDI devices over a 100-Mb fiber optic link.

Figure 1-1 shows the components of the multimode or single-mode Mod-FDDI card.

**Figure 1-1: Multimode or Single-Mode Mod-FDDI Card Components**

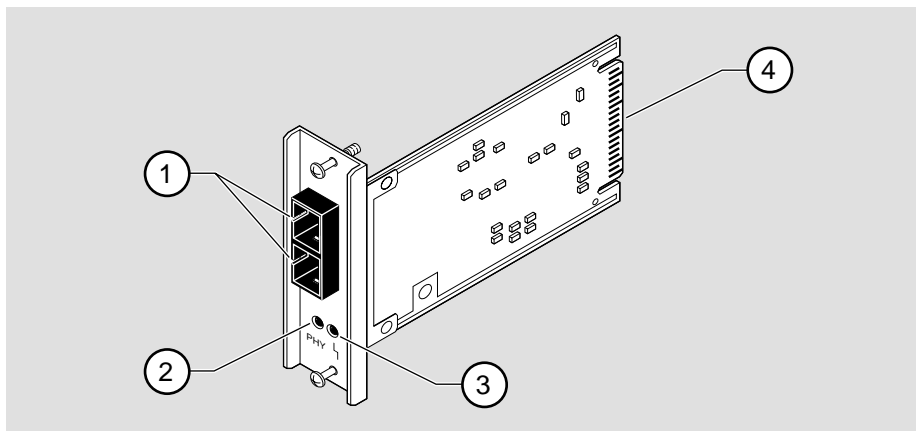

NPB-0705-96F

The following legend identifies the card components:

Item	Description
1	FDDI connectors
2	PHY LED
3	FRU State LED
4	50-pin host connector

## Introduction

### UTP Mod-FDDI Cards

The UTP Mod-FDDI (DEFYU-AA) card allows the connection of FDDI devices over a 100-Mb Category 5 (Cat. 5) unshielded twisted pair (UTP) copper link.

Figure 1-2 shows the components of the UTP Mod-FDDI (DEFYU-AA) card.

**Figure 1-2: UTP Mod-FDDI Card Components**

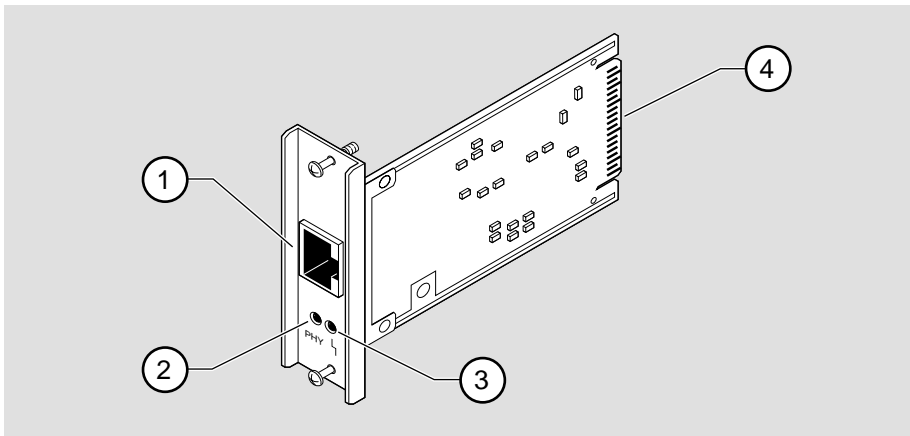

NPB-0706-96F

The following legend identifies the card components:

Item	Description
1	UTP connector
2	PHY LED
3	FRU State LED
4	50-pin host connector

---

## Hot-Swap Support

The cards can be inserted and removed without turning off power to the module. This is called hot swapping. However, make sure that your host module supports the hot-swap feature before attempting to perform this operation.

Refer to the host module documentation for information about the hot-swap feature.

---

### NOTE

Hot swapping a card in a host module that does not support the hot-swap feature does not damage the module, but can cause the card to behave erratically. If you are unsure of hot-swap support, DIGITAL recommends that you install the card into a module that is powered down.

---



## Chapter 2

---

# Installing the Card

---

## Overview

### Introduction

Before you begin to install a card into the module, you must understand whether the hot-swap feature is supported and what effects this might have. Refer to the host module's documentation for information about hot-swap support.

---

#### NOTE

Hot swapping a card in a host module that does not support the hot-swap feature does not damage the module, but can cause the card to behave erratically. If you are unsure of hot-swap support, DIGITAL recommends that you install the card into a module that is powered down.

---

The installation instructions in this chapter are applicable to both cards described in this manual.

### In This Chapter

---

Topic	Page
Installation Preparation	2-2
Preparing a Host Module	2-3
Removing the Slot Cover	2-4
Installing the Card	2-5
Removing the Card	2-7

---

## Installation Preparation

To prepare to install the card into the host module, complete the following steps:

---

Step	Action
1	Remove the contents from the box and be sure to keep all original packing materials. The card comes packed in protective antistatic material. You should not remove the card from the material until you are ready to install the card.
2	Check the shipment for damage and missing parts. In case of damaged or missing parts, contact your delivery agent and your DIGITAL sales representative.
3	Make sure you have the proper Modular Media Interface (MMI) card for your module. ATM modPHY, Fast Ethernet MM-100, and Mod-FDDI cards are not interchangeable.
4	Determine whether the host module supports the hot-swap feature. Refer to the host module's documentation.

---

## Required Tools

DIGITAL recommends the use of, but does not supply, the following tools to install the cards:

- Phillips-head screwdriver
- Antistatic grounding strap and grounded work surface

---

### CAUTION

Static electricity can damage modules and electronic components. DIGITAL recommends using a grounded antistatic wrist strap and a grounded work surface when handling any modules.

---



---

## Preparing a Host Module

To prepare your host module for the card installation, complete the following steps:

---

<b>Step</b>	<b>Action</b>
<b>1</b>	Refer to the host module's documentation to determine what steps you need to take before installing any cards.  For example, check to see whether you need to power down the system or remove any modules before attempting this operation.
<b>2</b>	Check the front of the module and determine which slots to use.

---

After you have completed these steps, go to the following sections:

---

<b>Topic</b>	<b>Page</b>
Removing the Slot Cover	2-4
Installing the Card	2-5
Removing the Card	2-7

---

---

## Removing the Slot Cover

To remove the host module's slot cover (Figure 2-1), complete the following steps:

---

Step	Action
1	Use a Phillips-head screwdriver to loosen the two captive screws that hold the slot cover in place, and remove the cover.
2	Save the slot cover and screws for future use.

---

**Figure 2-1: Removing the Slot Cover**

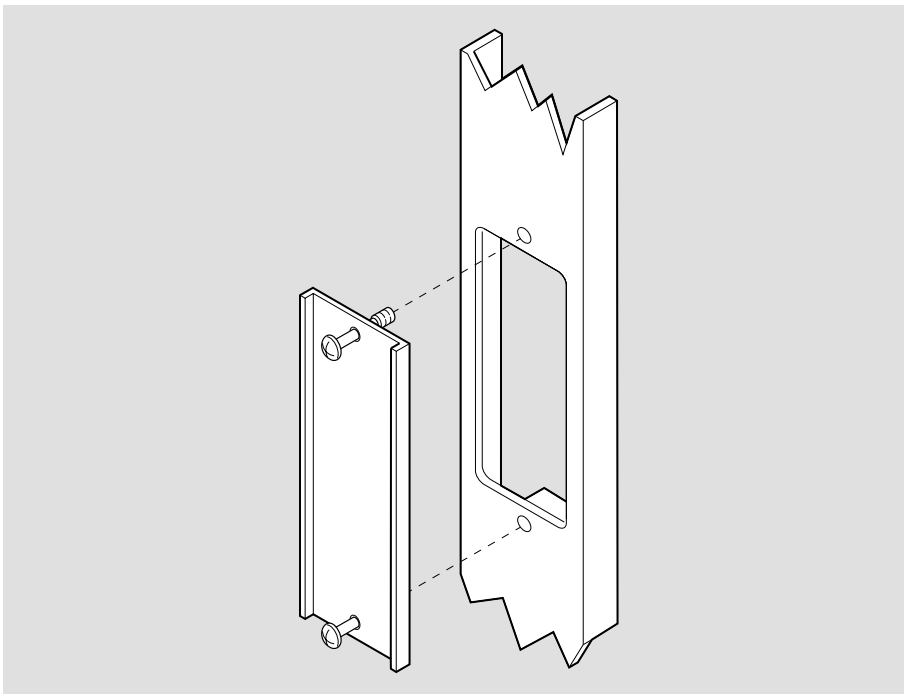

LKG-09986-96F

---

## Installing the Card

To install the card into a host module (Figure 2-2), complete the following steps:

---

Step	Action
1	Attach one end of the antistatic wrist strap to your wrist and the other end to a chassis ground. <b>CAUTION:</b> Static electricity can damage modules and electronic components. DIGITAL recommends using a grounded antistatic wrist strap and a grounded work surface when handling any modules.
2	Hold the card by the edges of the bezel and position it so that it is parallel with the slot opening.
3	Insert the card into the slot opening by aligning the sides of the card with the slot opening. <u>Note:</u> To prevent the screws from interfering with the card insertion, make sure that the captive screws on the bezel are partially threaded into the bezel threads.
4	Firmly fasten the card to the module with the two captive screws.

---

## Installing the Card

**Figure 2-2: Installing the Card**

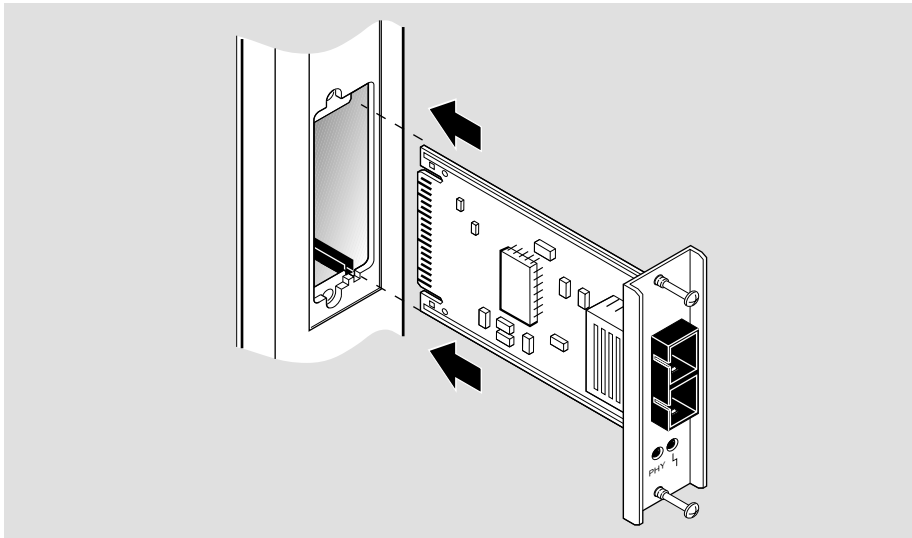

NPB-0904-97F

---

## Removing the Card

To remove a card from the host module (Figure 2-3), complete the following steps:

---

Step	Action
1	Attach one end of the antistatic wrist strap to your wrist and the other end to a chassis ground. <b>CAUTION:</b> Static electricity can damage modules and electronic components. DIGITAL recommends using a grounded antistatic wrist strap and a grounded work surface when handling any modules.
2	Disconnect all cables from the card. Refer to Chapter 3 for cable removal information.
3	Use a Phillips-head screwdriver to loosen the two captive screws that hold the card in place.
4	Grasp the captive screws and disconnect the card from the host module by pulling on the screws.
5	Gently slide the card out of the slot.
6	Replace the dust caps on the card, if necessary.
7	Place the card into a static-proof bag.
8	If the slot is to be unused, reinstall the slot cover.

---

## Removing the Card

**Figure 2-3: Removing the Card**

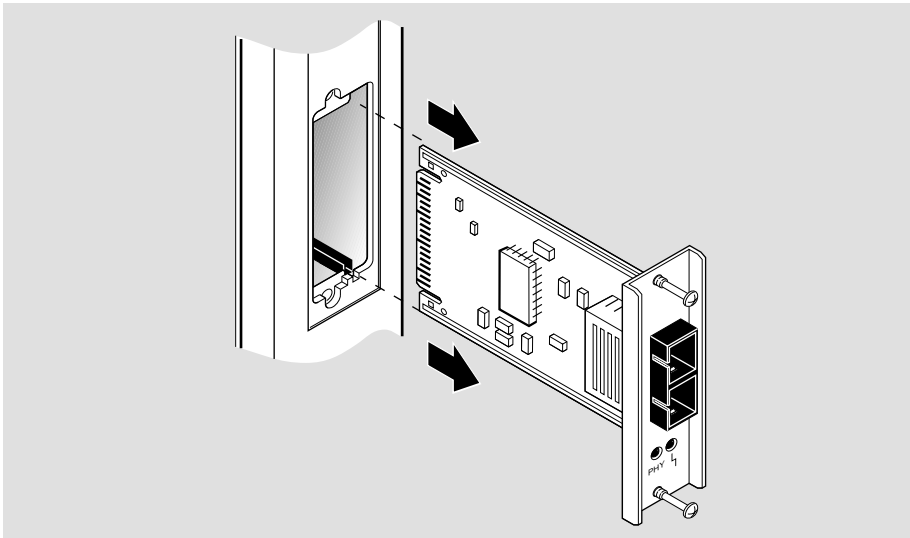

NPB-0905-97F

## Chapter 3

---

# Connecting and Removing Cables

---

## Overview

### Introduction

This chapter describes the connection and removal of cables for each type of physical media interface used in a card. This information applies to both types of cards.

### In This Chapter

Topic	Page
Connecting the Multimode or Single-Mode Fiber-Optic Cables	3-2
Removing the Multimode or Single-Mode Fiber-Optic Cables	3-4
Connecting the FDDI UTP Cable	3-5
Removing the FDDI UTP Cable	3-6

## Connecting the Multimode or Single-Mode Fiber-Optic Cables

This section describes the media connection information for the multimode or single-mode fiber-optic cables.

---

### WARNING

Some fiber-optic equipment can emit laser or infrared light that can injure your eyes. Never look into and optical fiber or connector port. Always assume the cable is connected to a light source.

---



To connect the cables, (Figure 3-1) complete the following steps:

---

Step	Action
1	Remove the dust caps from the ports.
2	Align the receive cable connector (1) with the receive port* and transmit cable connector (2) with the transmit port*.
3	Insert the cables.
4	Connect the other end of the cable to your network device.

---

---

*Symbol	Meaning
	Receive port
	Transmit port

---

---

### NOTE

Make sure that the bend radius of any fiber-optic cable is 2.5 cm (1 in) or greater. To avoid optical power loss, do not touch the fiber ends.

---



## Connecting the Multimode or Single-Mode Fiber-Optic Cables

**Figure 3-1: Connecting the Multimode and Single-Mode Fiber-Optic Cables**

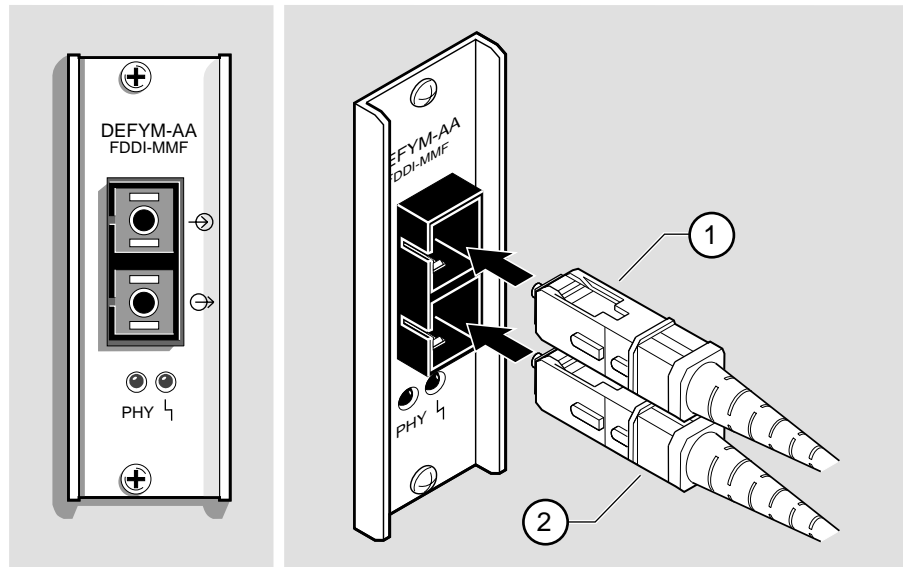

NPB-0707-96F

Although Figure 3-1 shows a multimode fiber-optic cable, the example also represents how you would connect the single-mode fiber-optic cable to the Mod-FDDI card.

---

## Removing the Multimode or Single-Mode Fiber-Optic Cables

To remove the cables (Figure 3-2), complete the following steps:

---

Step	Action
1	Pull the receive cable connector (1) and the transmit cable connector (2) from the ports.
2	Remove the other end of the cables from your network device.
3	Replace the dust caps.

---

**Figure 3-2: Removing the Multimode or Single-Mode Fiber-Optic Cables**

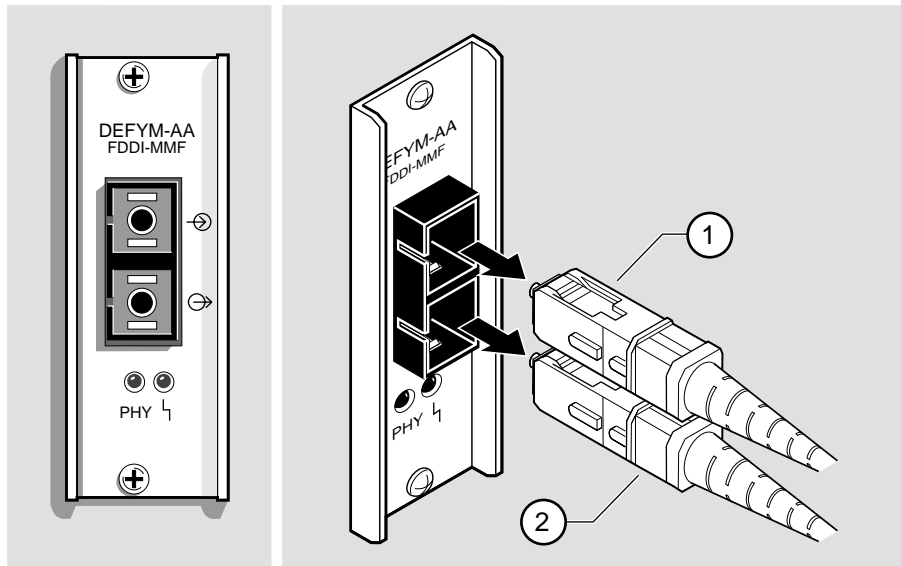

NPB-0708-96F

Although Figure 3-2 shows a multimode fiber-optic cable, the example also represents how you would connect the single-mode fiber-optic cable to the Mod-FDDI card.

---

## Connecting the FDDI UTP Cable

This section describes the media connection information for the FDDI UTP cables.

To connect the FDDI UTP cable (Figure 3-3), complete the following steps:

---

Step	Action
1	Align the release tab (1) on the cable plug with the keyway on the card port connector.
2	Insert the plug into the connector, ensuring that the release tab snaps into the locked position.
3	Connect the other end of the cable to your network device.

---

**Figure 3-3: Connecting the FDDI UTP Cables**

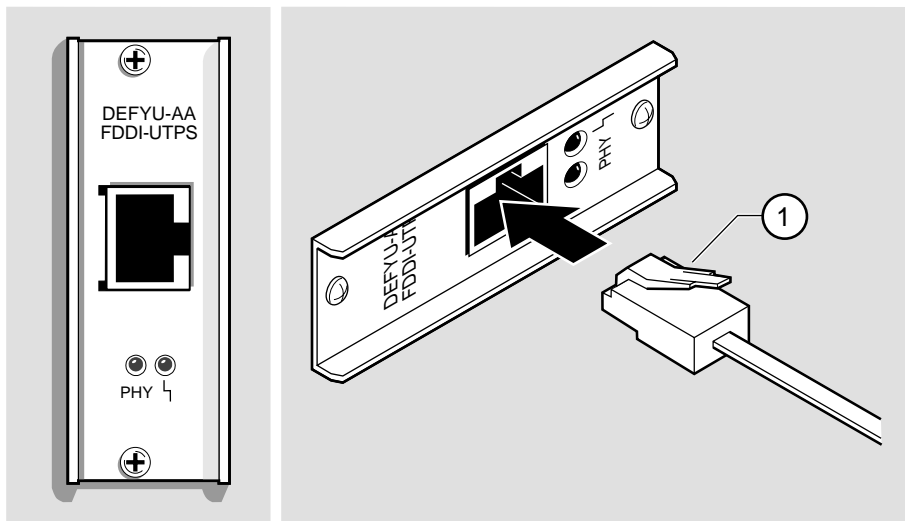

NPB-0538-96F

## Removing the FDDI UTP Cable

---

### Removing the FDDI UTP Cable

To remove the FDDI UTP cable (Figure 3-4), complete the following steps:

---

Step	Action
1	Press the release tab (1) on the cable plug, and disconnect the cable.
2	Remove the other end of the cable from your network device.

---

**Figure 3-4: Removing the FDDI UTP Cable**

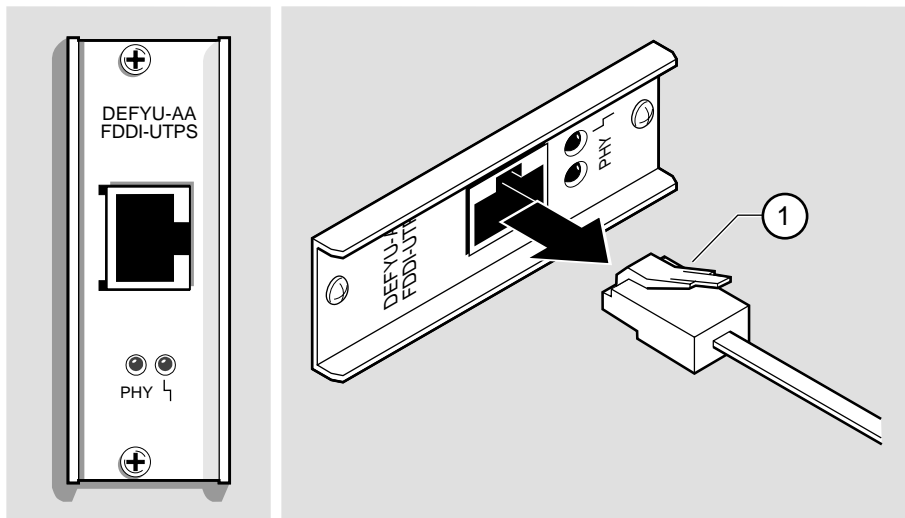

NPB-0535-96F

# Chapter 4

---

## Using the Card

---

### Overview

#### Introduction

This chapter explains the operation of the FDDI Modular Media Interface (Mod-FDDI) cards. The instructions in this chapter apply to both types of Mod-FDDI cards.

After you install a card and before you can use it, the card must be initialized.

#### In This Chapter

---

Topic	Page
Initializing the Card	4-2
Verifying Operability	4-4
LED Conditions	4-5
Performing a Loopback Test	4-6
Connecting a FDDI UTP Loopback Connector	4-7
Connecting a Multimode or Single-Mode Fiber-Optic Loopback Connector	4-8
If the Loopback Test Passes	4-9

---

## Initializing the Card

The card should be initialized after insertion into your host module. Host modules that support the hot-swap feature perform this procedure automatically. Refer to your host module's documentation for information about module initialization and the hot-swap feature.

If you are installing the card into a powered-down module, you need to return power to the module. Once you return power to the module, the initialization procedure is performed automatically.

If you install the card into a module with power, and the module does not support the hot-swap feature, you need to turn off and restore the power to the module. Then, the module initializes the card.

After initialization, the two LEDs on the card provide information about its operation.

---

<b>Symbol</b>	<b>Description</b>
PHY	The Physical Layer (PHY) LED indicates the state of the Physical Layer interface.
	The field-replaceable unit (FRU) status LED indicates the port's fault or diagnostic status. If the card initializes properly, the FRU LED indicates the PHY type.

---

The following table describes what you might see after initialization, assuming that the port is directed to the front panel.

## Initializing the Card

If your module...	Then...
Supports the hot-swap feature	The PHY LED blinks three or more times after the card is inserted to indicate that recognition and initialization of the card is being attempted.
Supports the hot-swap feature, but either the card or the module has a fault that prevents recognition of the card	The FRU LED lights solid yellow immediately after you insert the card. Take one of the following actions: <ul style="list-style-type: none"><li data-bbox="777 898 1219 982">• Repower the module. Refer to your host module's documentation for more information.</li><li data-bbox="777 995 1016 1026">• Replace your card.</li><li data-bbox="777 1039 1159 1092">• Contact your Digital Equipment Corporation Representative.</li></ul>
Was powered up before the insertion of the card and it does not support the hot-swap feature	None of the LEDs light within 10 seconds after you insert the card, and no initialization takes place. The module needs to be repowered.

Table 4-1 describes other LED indications that occur after this point.

## Verifying Operability

A card might be operational but inactive because it is not connected to a remote system. In this situation, the PHY LED is off.

The PHY LED should blink three or more times when you hot swap the Mod-FDDI card. If the card initializes properly, the FRU LED indicates the PHY type:

<b>If the FRU LED is...</b>	<b>This Indicates an...</b>
Solid green	S-type PHY
Flashing yellow	A- or B-type PHY
Off	M-type PHY
Solid yellow	Error, contact your DIGITAL representative.

When the Mod-FDDI is connected to another system, verify that the connection is active by checking the LEDs. Refer to Table 4-1 to determine if you need to take any action.



---

## LED Conditions

Table 4-1 describes the conditions of the LEDs.

**Table 4-1: LED Conditions**

Symptom	Probable Cause	Corrective Action
FRU LED is off.	Tree topology, M-type port.	No action necessary.
FRU LED is green.	Tree topology, S-type port.	No action necessary.
FRU LED is yellow.	The diagnostics have detected a fault.	If possible, insert the card into another slot to determine whether the card or the host module contains the fault. If the card contains the fault, replace your card or contact your Digital Equipment Corporation representative.
FRU LED is blinking green.	Dual ring, A port or B port.	No action necessary.
PHY LED is off.	The port is unable to receive from the neighboring switch or station indicating that there might be a connection problem.	Check your connection (see section titled Checking the Connections on page 4-6).
PHY LED is green.	The card is working properly and a link is established.	No action is necessary.
PHY LED is yellow.	The link error rate limit has been exceeded.	Perform loopback testing to isolate the problem.
PHY LED is blinking green.	The card has been disabled by network management.	Enable the card, if necessary.
PHY LED is blinking yellow.	Illegal connection.	Check the connections (see section titled Checking the Connections on page 4-6).
PHY LED is blinking green and yellow alternately.	The card is in standby (dual homing) mode.	No action is necessary.

---

## Performing a Loopback Test

Loopback connectors help to isolate your connection problems. Loopback testing verifies the ability of a port to transmit and receive data and isolates a problem to a particular element of a connection, that is, one of the ports or the media connecting them. Tests on the individual ports allow independent verification of each port as operational.

The loopback test configuration involves connecting a particular port's transmitter to its own receiver. (Special connectors or cables might be required.) If the loopback connectors are properly connected, the PHY LED activity depends on the PHY type.

---

With PHY type...	If the PHY LED is...	Then...
S	green	the port is operational.
M, A, or B	blinking yellow	the port is operational.
All Phy types	solid yellow or off	the port is not transmitting or receiving. Contact your DIGITAL service representative.

---

## Checking the Connections

Before performing the loopback test, check the following conditions:

---

Step	Action
1	Ensure that you have the correct cable for your particular type of port.
2	If the correct cables are being used, test the port connections with loopback connectors.

---

---

## Connecting a FDDI UTP Loopback Connector

To connect a FDDI UTP loopback connector, complete the following steps:

---

Step	Action
1	Remove the FDDI UTP cable from the card.
2	Align the keyway on the loopback plug with the key on the connector.
3	Insert the plug into the connector, ensuring that the locking clip on the plug snaps into the locked position.

---

**Figure 4-1: FDDI UTP Loopback Connector**

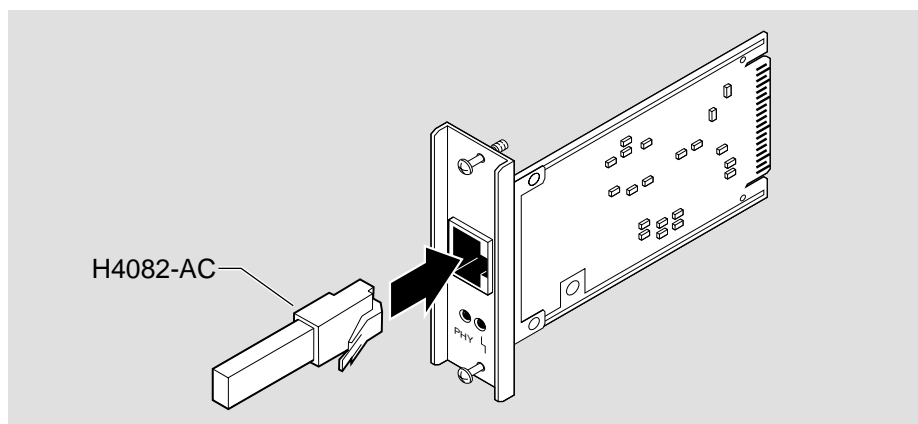

NPB-0709-96F

---

## Connecting a Multimode or Single-Mode Fiber-Optic Loopback Connector

To connect a multimode (see Figure 4-2) or single-mode loopback connector, complete the following steps:

---

Step	Action
1	Remove the cable from the card.
2	Line up the transmit cable connector with the transmit port and the receive cable connector with the receive port.
3	Insert the loopback connector.

---

**Figure 4-2: Connecting a Multimode Fiber-Optic Loopback Connector**

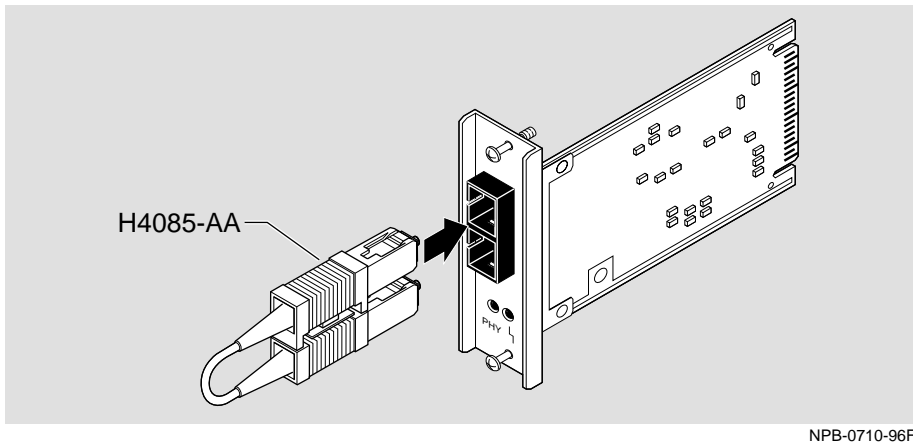

Refer to Appendix A for more information about the appropriate loopback connectors to use for testing different types of ports.

If the Loopback Test Passes

---

## If the Loopback Test Passes

If the port passes the loopback test, take one of the following actions:

---

<b>If...</b>	<b>Then...</b>
Neither port is identified as faulty	Replace the cables.
Replacement cables are not available	Perform continuity tests or cable loss measurements to identify the cable problems. Repair the cables.

---



# Appendix A

---

## Cable and Connector Information

---

### Overview

This appendix describes cable and connector information and specifications for each cable type.

### In This Appendix

Topic	Page
Multimode Fiber-Optic Cable and Connector Information	A-2
Multimode and Single-Mode Cable Specifications	A-4
FDDI UTP Cable and Connector Information	A-6
FDDI UTP Cable Specifications	A-7

## Multimode Fiber-Optic Cable and Connector Information

The following multimode fiber-optic cables and loopback connectors are available from Digital Equipment Corporation:

Cable Description	Order Number
FDDI SC-type to FDDI SC-type	BN34B-xx <sup>1</sup>
FDDI SC-type to 2.5 ST-type	BN34A-xx <sup>1</sup>
Loopback connector	H4085-AA

<sup>1</sup> The symbol xx represents the cable length. The available cable lengths are described in the *OPEN DECconnect Applications Guide*.

Figure A-1 shows the multimode fiber-optic cable. Figure A-2 shows the multimode fiber-optic loopback connector.

If you connect your VNswitch 900 module to an optical bypass relay (OBR) device, you require an SC to ANSI media interface connector (MIC) cable assembly and an ANSI MIC to ANSI MIC coupler. The SC to ANSI MIC cable assembly is available from DIGITAL (BN34D-xx).



## Multimode Fiber-Optic Cable and Connector Information

**Figure A-1: Multimode Fiber-Optic Cables**

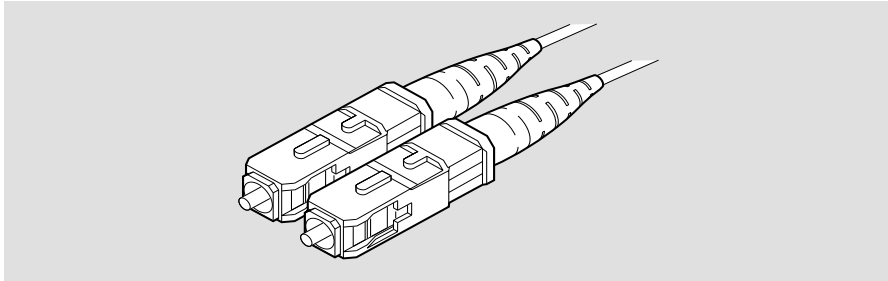

NPB-0645-96F

**Figure A-2: Multimode Fiber-Optic Loopback Connector**

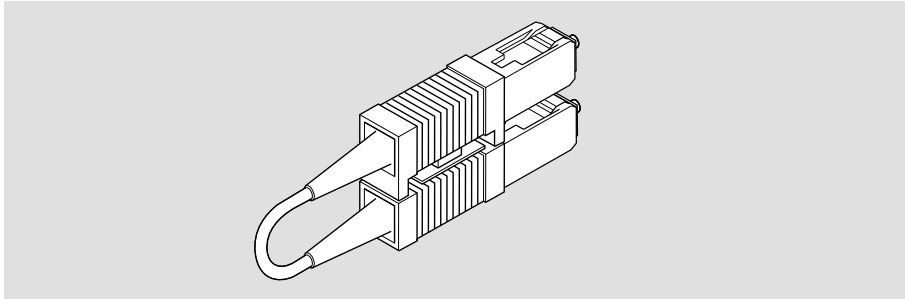

NPB-0697-96F

## Multimode and Single-Mode Cable Specifications

### Multimode Fiber-Optic Cable Specifications

The multimode fiber-optic cables should adhere to the following specifications:

- EIA/TIA 492-AAAA
- 62.5/125  $\mu\text{m}$
- SC connector
- 0 through 2 km
- 0 through 11 dB loss at 1300 nm (ANSI X3.166-1990, FDDI PMD)

### Single-Mode Fiber-Optic Cable Specification

The single-mode cables should adhere to the following specifications:

- Cable plant loss of between 12 dB and 22 dB (measured at a wavelength of 1300 nm).
- Cable plant attaches to the FDDI device through SC/PC-type connectors.
- Cables have an optical fiber that conforms to EIA/TIA 492CAAA and for which the cutoff wavelength is 1240 nm or less.
- Use inline loss elements with cables of less than 12 dB of loss. Use one of the following types of inline loss element, as appropriate:

---

<b>Cable Loss</b>	<b>Loss Element Rating</b>
0 to 6 dB	12 to 16 dB
6 to 12 dB	6 to 10 dB

---

## Multimode and Single-Mode Cable Specifications

- Use loss elements with the Mod-FDDI SC single-mode connector DEFYS-AA as appropriate for the far-end connection. The following table shows how to determine the placement of loss elements when connecting modules that use DIGITAL FDDI single-mode connectors:

<b>If the near-end connection is...</b>	<b>And the far-end connection is ...</b>	<b>Then a loss element is required in...</b>
FC connector (DEFXS-AA, ModPMD)	FC connector	Both Receive port* links.
	ST connector	Both Receive port links.
	SC connector	FC connector Receive port link only.
ST connector (DEFXS-BA, ModPMD)	FC connector	Both Receive port links.
	ST connector	Both Receive port links.
	SC connector	ST connector Receive port link only.
SC connector (DEFYS-AA, Mod-FDDI)	FC connector	FC connector Receive port link only.
	ST connector	ST connector Receive port link only.
	SC connector	No loss element required.

\* The following symbol indicates the Receive port: 

---

## FDDI UTP Cable and Connector Information

The following FDDI UTP cables and loopback connectors are available from Digital Equipment Corporation:

Cable Description	Order Number
8-pin MP to 8-pin MP Category 5 (crossover)	BN25H
8-pin MP to 8-pin MP Category 5 (straight-through)	BN25G
Loopback connector	H4082-AC

BN25H contains crossover wiring. BN25G contains straight-through wiring. Refer to the *OPEN DECCONNECT Applications Guide* for information about installed wiring and other configurations. Figure A-3 and Figure A-4 show the UTP FDDI cable and loopback connector.

**Figure A-3: FDDI UTP Cable**

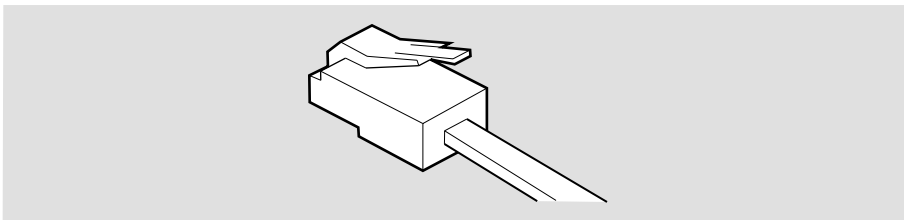

NPB-0602-96F

**Figure A-4: FDDI UTP Loopback Connector**

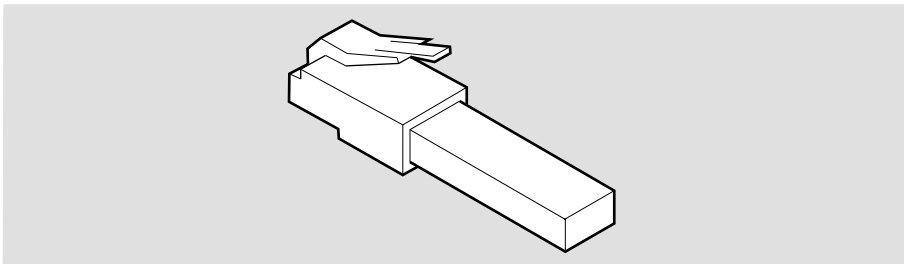

NPB-0647-96F

---

## FDDI UTP Cable Specifications

The FDDI UTP cables should meet the requirements of EIA/TIA-568B for Category 5 twisted-pair for FDDI installation.

### 8-Pin MJ Connector

Figure A-5 shows the 8-pin MJ connector and its pin assignments:

**Figure A-5: 8-Pin MJ Connector**

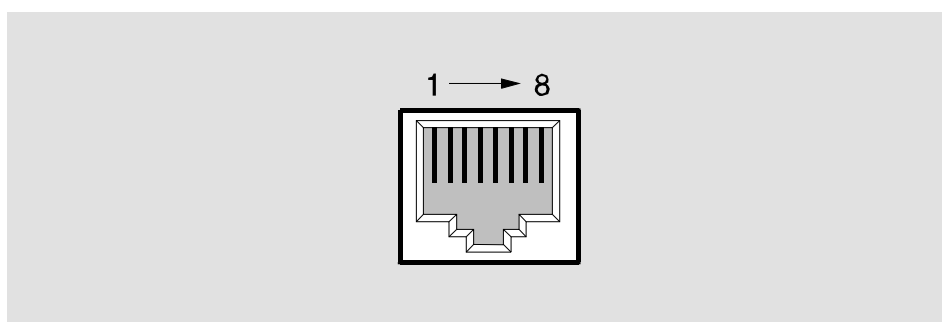

NPG-8719-95F

Table A-1 lists the pin assignments for the FDDI UTP 8-pin MJ connector.

**Table A-1: 8-Pin MJ Pin Assignments**

Pin	Assignment	Pin	Assignment
1	Transmit +	5	Unused
2	Transmit -	6	Unused
3	Unused	7	Receive +
4	Unused	8	Receive -

