

DIGITAL

FCO

CATEGORY

PAGE 1

[F]

OF 15

FIELD CHANGE ORDER

NUMBER: DS-650Q8-F001

APPLICABILITY:

This FCO should be installed on all MIRA systems shipped before 03-July-1989
(Continued on Page 2)

PROBLEM & SYMPTOM: Cross-talk problem between Dispatcher cable and switched cable. Revision incompatibility problem between M7764-00 and M7763-00 module
(Continued on Page 3)

SOLUTION: (See Page 3)

QUICK CHECK: (See Page 3)

PRE/COREQUISITE FCO: None

MTTI HRS

3.5 Hrs

TOOL/TEST EQUIPMENT: None

FCO PARTS INFORMATION

FCO KIT NO.	DESCRIPTION OF CONTENTS	EQ KIT VARIATION APPLICABILITY
EQ-01568-02	2 M7763-00, 4 M7764, 2 cables 70-27118-03 2 cables 70-27118-06	N/A
FA-04892-01	FCO Document	

FCO CHARGING INFORMATION

WARRANTY/CONTRACT

NONWARRANTY/NONCONTRACT

ON-SITE

OFF-SITE

ON-SITE

OFF-SITE

MATERIAL ONLY

TRAVEL/ INSTALL	EQ KIT	INSTALL	EQ KIT	TRAVEL/ INSTALL	EQ KIT	INSTALL	EQ KIT	ORDER-ADMIN, HANDLING PKG, SHIPPING & EQ KIT
DEC	DEC	DEC	DEC	CUS	CUS	CUS	CUS	CUS

APPROVALS

CSSE

FSHQ LOGISTICS

FS PRODUCT SAFETY

J-Claude Chalumeau

Rick Orlando

Bob Brister

CSSE MANAGER Guy Caillaud	FS. MICROFICHE LIBRARIES VAXDOC EP-CSVDC-LB	FCO RELEASE DATE 9 April 1990
MICROMEDIA Diane MacDonald	STARS VAX Notes	FCO REVISION A
POPULATION 11		PARTS AVAILABILITY May, 1990

```

- - - - -
|d|i|g|i|t|a|l|
- - - - -

```

FCO DS-650Q8-F001

PAGE 2 OF 15

Applicability: (Continued from Page 1)

MIRA MicroVAX 3000 (also called MIRA 3200) with the following part numbers shipped before 03-JULY-1989 require this FCO.

- o DS-650Q8-A2/A3

System revisions are not significant for the application of this FCO. They are built with M7763 or M7764 at Rev. D or below.

This FCO is also required for Special Customized MIRA systems (not always referred to with the part numbers listed above), that use the MIRA logic modules M7763 and M7764 at Revision D or below.

This FCO incorporates ECO's M7763-AE006, M7764-AE004.

This FCO also provides all the functionality enhancements made in the following ECO's:

- o M7763-AE004 Implement DC LOW
- o M7764-AE003 add LM339 to drive DCOK (DC LOW)
- o M7763-AE005 etch re-layout to suppress extra wires

Implementation: Planned call, as the whole system must be shutdown, and the customer application must be stopped to install this FCO.

FCO DS-650Q8-F001

Problem/Symptoms: (Continued from Page 1)

Intermittent data corruptions happen when testing switched KMV1A with MDM Diagnostics in MIRA Systems. The data was corrupted by cross-talk between cables generated by the BC05L cable between the MIRA watch-dog Module (M7763-00) and the dispatcher module (M7764-00).

A re-layout of the two modules M7763-00 and M7764-00 has been necessary to adapt the impedances between these modules. Both M7764 and M7763 become Rev. E with the new etch. A new cable 70-27118 has been designed to replace the BC05L cable.

The new modules M7763 and M7764 at Rev. E cannot be used with the previous Revision D or below.

Solution: (Continued from Page 1)

Replace all modules M7763 and M7764 at Revision D or below by new modules at Rev. E and replace BC05L dispatcher cables at one time.

Quick Check: (Continued from Page 1)

If all the cables on the watch-dog module M7763-00 are flat cables this FCO is required.

If you find a round cable (70-27118-03) connected to the M7763, the module is at the correct Revision (E), and the FCO is not required.

NOTE: This can be checked in both systems A or B, as they must be identical in terms of revision levels of M7763.

WATCH DOG MODULE TO BE REPLACED

COMPUTER A
CPU BOX SLOT 3

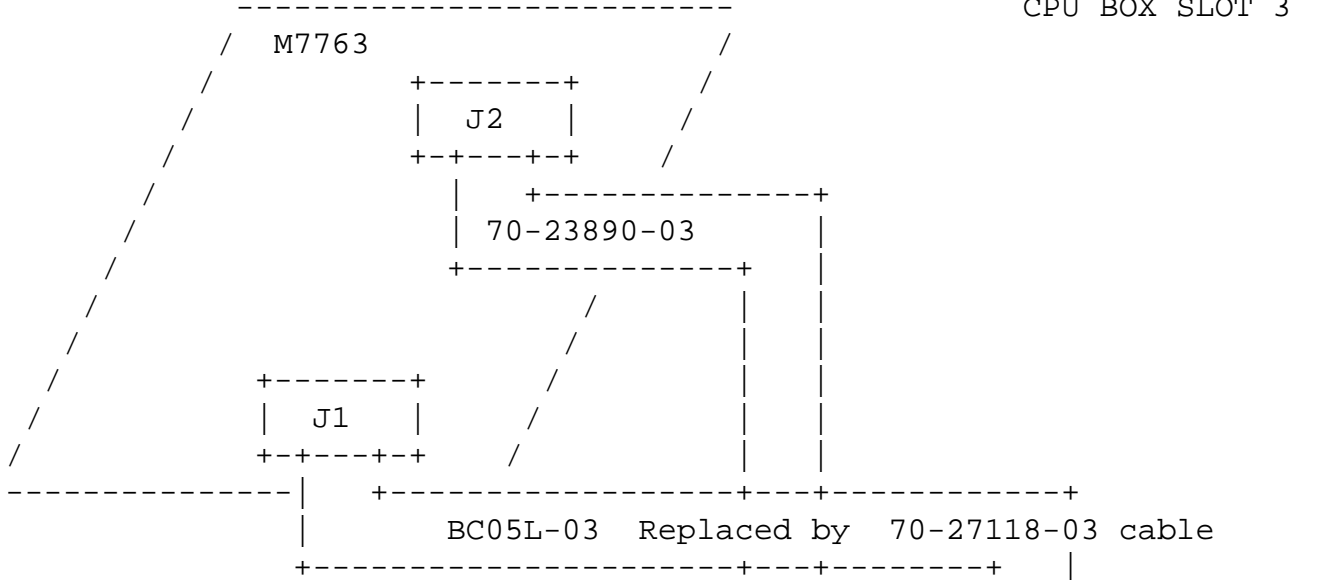

DISPATCHER MODULE TO BE REPLACED

SWITCHING
BOX A
SLOT 1

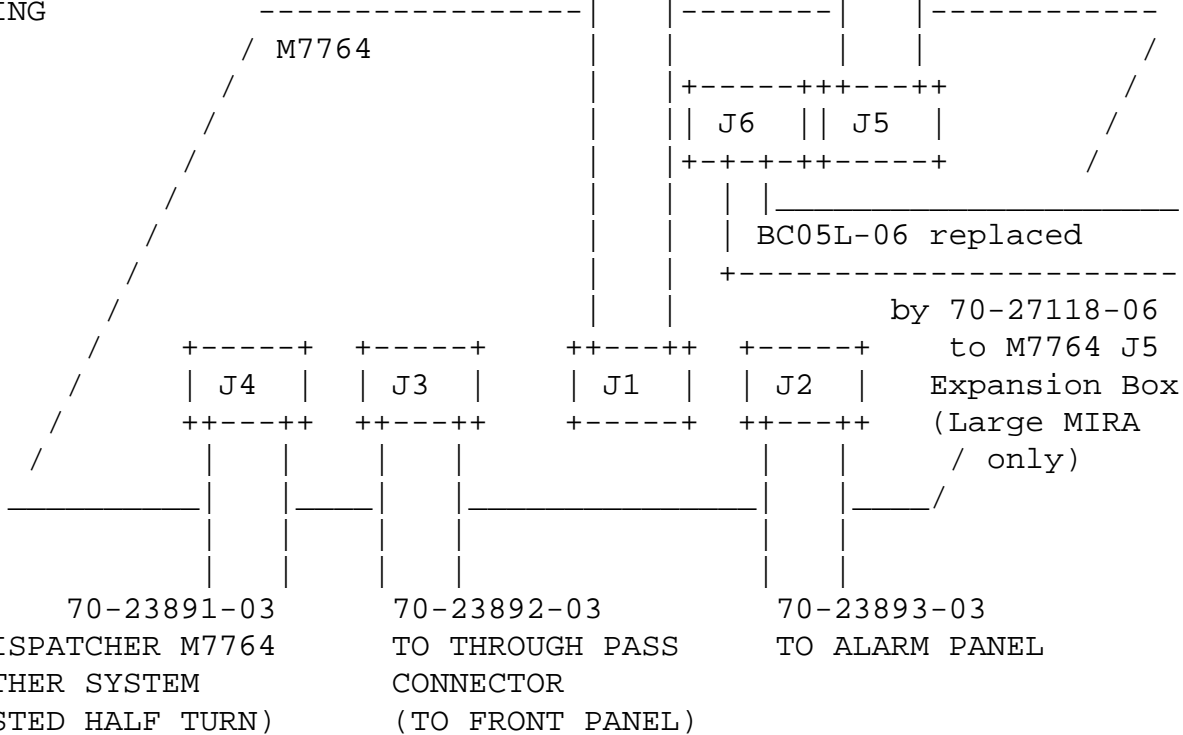

_	_	_	_	_	_	_	_	_
d	i	g	i	t	a	l		
_	_	_	_	_	_	_	_	_

FCO DS-650Q8-F001

Preliminary Recommendations:

This FCO replaces all watch-dog, dispatchers modules and BC05L cables attached to these dispatchers. This replacement requires the complete MIRA to be powered down.

Before making any modifications to the system, insure both MIRA systems have no hidden faults in their hardware.

The best way to check complete MIRA system integrity is to ask the System Manager or User to run the MIRA TEST command and if the test is successful, to make a MIRA SWAP with his application.

If the system has a fault somewhere, do not attempt to implement this FCO, but fix the system first.

The interconnection of the modules and cables to be replaced is shown on Page 4.

The test procedures under VMS are separate and given on Page 11.

The watch-dog link cable (70-23891-03) between the A and B systems, connected on J4 of M7764 modules in switching boxes 0, is a half-turn between both systems. It is wise to mark the upper side on both ends of this cable before disconnecting.

There are some "traps" with in MIRA behavior for non-aware persons during use of diagnostics. See Test procedure on Page 10 for details.

=====
WARNING
=====

The customer might have modified the SYSTARTUP.COM to include the startup of MIRA software. Some processes require undetermined time to start, and could cause TIME-OUT when the software MIRA is started. To avoid this potential problem of MIRA time-out when you will reboot the Operating System, you must check the SYSTARTUP.COM on both System A and B before you stop the system. If MRA\$STARTUP is included in the system startup command file, modify the SYSTARTUP file and put the MIRA start command (@SYS\$MANAGER:MRA\$STARTUP) as a comment line. You must do these checks and modifications on both Systems A and B. This will allow you to start MIRA software manually and check the system as described on Page 11 after you have installed the FCO.

Field Installation

Pre-test of system

1. Check the SYSTARTUP files on both systems as described in the ****WARNING**** on Page 5. Modify the files if necessary and ask the System Operator to stop the application. Installation of this FCO needs to stop both Systems A and B, as it will later require removing of BC05L-06 cable in the FCC pipe on large systems.
2. Run MIRA test on System A and System B (see test on Page 11).
3. If MIRA test is successful on both systems, issue a SWAP at operator console. If MIRA SWAP fails do not attempt to install this FCO. Refer to MIRA Installation and Maintenance Guide, EK-MIRAI-MM.
4. Stop MIRA on both systems using MIRA STOP DCL command.
(standby first, then Master)
5. Shut down the system by executing the Shutdown Command Procedure.

\$ @SYS\$SYSTEM:SHUTDOWN on both systems.

FCO Hardware Installation

6. Power-Off Instructions

After the system has been powered-down, switch off both CPU A and B with Front Panel CPU switches. Place the two Circuit Breakers for System A at the top of cabinet and System B at the bottom of cabinet, in the "OFF"(0) position. Wait five minutes to allow the capacitors to bleed down.
7. Use ALL ESD safety precautions to prevent DOA modules in upgrade kit.
8. Utilize static strap. Unpack FCO material.
9. On System A (Top system):
10. Open the Unswitched I/O panel door.
11. Remove the M7763-00 module from slot 3. Note switch settings.
12. Disconnect cable BC05L-03 from connector J1.
13. Mark orientation and disconnect cable 70-23890-03 (20 pins)

from connector J2.

_	_	_	_	_	_	_	_	_
d	i	g	i	t	a	l		
_	_	_	_	_	_	_	_	_

FCO DS-650Q8-F001

PAGE 7 OF 15

-
14. Take the new module M7763-00 at Rev. E and reconnect the cable 70-23890-03 (20 pins) into connector J2.
 15. Connect the new round cable (3 feet) 70-27118-03 into J1 of the M7763 module (note mark on connector upside).
 16. Set CSR and Vector address switches as on the old M7763 module (See switch settings on Page 14, if necessary).
 17. Plug the new M7763-00 into slot 3 of CPU box.
 18. Route the new round cable 70-27118-03 to the switching box 0. (It will go to the dispatcher M7764 in slot 1 of this box).
 19. Remove the dispatcher module M7764-00 from slot 1 of switching box 0. Note the E5 switch position on the left of the board. (See switch settings on Page 14, if necessary).
 20. Disconnect cables from connectors J5, J6, J2, J1, J3, J4.
 21. Reconnect cables on the new M7764-00 Rev. E module on connectors J2, J1, J3, J4. Note cables orientation especially J4 (watch-dog link).
 22. Replace the BC05L-03 cable from the M7763-00 by the round cable (3 feet) 70-27118-03. Connect it to J5 (right hand side) of the M7764 module. Note that J5 and J6 locations can vary on previous revisions modules (A, B, C or D).
 23. Remove the BC05L-03 flat cable from the system, store it for return to logistics.
 24. Connect the new second round cable (6 feet) 70-27118-06 in connector J6 of the M7764 module. Although this new cable is thicker than the flat one, it fits between the module and the top of the box.
 25. Set up the E5 switches as they were on the old M7764 module.
 26. Plug the M7764 Module in the backplane.

-
27. Open the expansion cabinet, and open the Top I/O panel.
 28. Extract the M7764 module from the slot 1 of the extension switch box 1.
 29. Note the switch positions at location E5.
 30. Disconnect the flat cable BC05L-06 from connector J5 or J6.
 31. Remove this BC05L-06 cable from the FCC pipe between both cabinets. Store it for return to logistics. Be careful not to disconnect other cables when removing this cable from the FCC pipe.
 32. Route the new round cable 70-27118-06 from the M7764 dispatcher J6 connector (the left hand one) in the CPU cabinet through the FCC pipe to the top extension switch box of the second cabinet. Be careful not to disconnect other cables.
 33. Take the second M7764 Rev. E module from the EQ kit.
 34. Connect the round cable 70-27118-06 to the J5 connector (on the right hand side of the M7764 module).
 35. Set up E5 switches as they were on the old modules.
 36. Plug the M7764 module into slot 0 of the switching box. Although this new cable is thicker than the flat one, it fits between module and the top of the box.
 37. Insure all the cables are properly set up in the box.
 38. Close the I/O panel box of the expansion cabinet.
 39. Go to the main CPU cabinet. Close I/O Panel.
 40. Check if all cables are properly set up. Close the CPU panel.
 41. You can now Power-up System A. Observe the CPU self test sequence. (It is possible to see a double boot during self tests, this is not a failure, the second pass must be OK, proceed to next step).
 42. Start loading of diagnostics on the CPU A.

43. Once the diagnostics are loading, you can start the FCO installation on System B.

```
|_|_|_|_|_|_|_|_|_|
|d|i|g|i|t|a|l|
|_|_|_|_|_|_|_|_|_|
```

FCO DS-650Q8-F001

PAGE 9 OF 15

Upgrade System B

44. Repeat the similar procedure for System B to replace M7763 and M7764 modules and cables, using the same recommendations as mentioned in Step's 10 through 40.
45. Do not power-on System B immediately.

Testing MIRA with Diagnostics

46. Test System A with MDM Diagnostics. Once the diagnostics are loaded, you can power up System B and start loading of diagnostics on System B.
47. Running system exerciser tests in verify mode on both systems A and B is normally sufficient. During MIRA tests check warning messages, to insure switching boxes and switching modules are correctly seen by the MIRA diagnostic. See diagnostics for details on Page 10.
48. When Diagnostics have been run successfully, power-off both Systems A and B to reset the entire system.

Testing MIRA under VMS

49. Power-on both systems and Boot the Operating System on both CPU's.

WARNING: After FCO installation the MIRA Software will fail if only one CPU is booted with Operating system.

50. Log in as system operator.
51. Test MIRA as described in MIRA Testing procedure on Page 11.
52. Modify the SYSTARTUP files if necessary and ask the System Operator to restart his application.

53. Update the modules revisions to E1 and system revision level to A3 on the MIRA configuration sheet in the cabinet.
54. Package the material in the same ESD boxes and close boxes.
55. Update the Site Management Guide to reflect this FCO.
56. Report this FCO activity on the LARS in the "Fail Area/Module/FCO/Comments" column as per example on Page 15.
57. Return the old material ASAP to Logistics Center.

```
|_|_|_|_|_|_|_|_|_|
|d|i|g|i|t|a|l|
|_|_|_|_|_|_|_|_|_|
```

FCO DS-650Q8-F001

PAGE 10 OF 15

MIRA STANDALONE DIAGNOSTICS (using MDM)

For the FCO installation test purpose it is sufficient to run Exerciser Test in Verify Mode.

As non-switched options and switched options cabling is not modified there is no need to test the system with external loopbacks.

The MIRA functional tests provide informations that must be carefully checked after installation of this FCO. They are given by warnings and information messages:

- o The switch boxes not present or recognized by the test are noticed by warning messages. As you have a large MIRA with two boxes you must not have any warning for switching boxes.
- o The switching modules present in the system must all be listed with messages like:

"switching module address 1 present in Box 0"

Additional information on Alarm are given too.

WARNING only if you need to run in SERVICE MODE

DO NOT ATTEMPT TO RUN TEST IN SERVICE MODE UNLESS YOU SUSPECT CABLING PROBLEM on Alarm Panel, MIRA Control Panel, or switched option.

MIRA MDM diagnostics used in SERVICE MODE differs considerably from usual Diagnostics Test. In practice all the tests need the use of the MIRA utilities to close or open switches. MDM releases below release 128 need use of MDM in command line mode or special set up for Menu mode described in MIRA release notes, EK-MIRAI-RN-001.

System Exerciser Test

Do not attempt to use it with loopback at I/O panel level, if you are not familiar with MIRA tests with switched options. This test needs to close the MIRA switches using MIRA utilities, before you start exerciser. MIRA tests are organized into groups of subtests (See Maintenance Manual, EK-MIRAI-MM, Chapter 3.7.6). Two major modes are available:

INSTALLATION MODE: When both systems are not booted with Operating System. Use this mode preferably to check the system for FCO if necessary.

MAINTENANCE MODE: One system is running application, stand alone diagnostics on the other. In this mode the MIRA diagnostics communicates with MIRA Driver of the Master system to check availability of the switches.

```
-----  
| | | | | | | | |  
| d | i | g | i | t | a | l |  
| - | - | - | - | - | - | - |
```

FCO DS-650Q8-F001

PAGE 11 OF 15

MIRA TESTING PROCEDURE UNDER VMS

(Typical check when starting a MIRA system, useless messages have been deleted)

Username: SYSTEM

Password:

Welcome to VAX/VMS V4.7A

\$ @MRA\$STARTUP

- MIRA Driver loaded *-*

\$ MIRA

MIRA> SHO VERSION

MicroVAX MIRA Switch Control Software Version 2.1-B

MIRA> SHOW

```
Local System State      :      MASTER Remote System State      :      UNKNOWN  
Swap State              :      ENABLED  
Dc Low State           :      DISABLED  
Local Timer Value      :      .3 s
```

Clock Synchronization : DISABLED

Module	Module State	Switch Map
0	DISC/NOSWITCH	UNASSIGNED
1	CONNECTED	SAME
2	CONNECTED	SAME
3	CONNECTED	SAME
4	CONNECTED	SAME
5	DISC/NOSWITCH	UNASSIGNED
6	DISC/NOSWITCH	UNASSIGNED
7	DISC/NOSWITCH	UNASSIGNED
8	DISC/NOSWITCH	UNASSIGNED
9	DISC/NOSWITCH	UNASSIGNED
10	DISC/NOSWITCH	UNASSIGNED
11	DISC/NOSWITCH	UNASSIGNED

Total Connected: 4 Total Assigned: 4

MIRA> TEST

Local loop test : OK
Remote loop test : OK
Watchdog link connected
Switching box 0 connected
Switching box 1 not connected
Front panel connected
Alarm I/O panel connected

Module	Test	Status
0	FAIL/NOSWITCH	DISC/NOSWITCH
1	OK	CONNECTED
2	OK	CONNECTED
3	OK	CONNECTED
4	OK	CONNECTED
5	FAIL/NOSWITCH	DISC/NOSWITCH
6	FAIL/NOSWITCH	DISC/NOSWITCH
7	FAIL/NOSWITCH	DISC/NOSWITCH
8	FAIL/NOSWITCH	DISC/NOSWITCH
9	FAIL/NOSWITCH	DISC/NOSWITCH
10	FAIL/NOSWITCH	DISC/NOSWITCH
11	FAIL/NOSWITCH	DISC/NOSWITCH

```

|_|_|_|_|_|_|_|_|
|d|i|g|i|t|a|l|
|_|_|_|_|_|_|_|_|

```

FCO DS-650Q8-F001

PAGE 12 OF 15

MIRA TESTING PROCEDURE UNDER VMS (continued)

MIRA> SHO

Local System State : MASTER Remote System State : STANDBY

Swap State : ENABLED
Dc Low State : DISABLED
Local Timer Value : .3 s
Clock Synchronization : DISABLED

Module	Module State	Switch Map
0	DISC/NOSWITCH	UNASSIGNED
1	CONNECTED	SAME
2	CONNECTED	SAME
3	CONNECTED	SAME
4	CONNECTED	SAME
5	DISC/NOSWITCH	UNASSIGNED
6	DISC/NOSWITCH	UNASSIGNED
7	DISC/NOSWITCH	UNASSIGNED
8	DISC/NOSWITCH	UNASSIGNED
9	DISC/NOSWITCH	UNASSIGNED
10	DISC/NOSWITCH	UNASSIGNED
11	DISC/NOSWITCH	UNASSIGNED
Total Connected: 4		Total Assigned: 4

MIRA> TEST

Local loop test : OK
Remote loop test : OK
Watchdog link connected
Switching box 0 connected
Switching box 1 not connected
Front panel connected
Alarm I/O panel connected

Module	Test	Status
0	FAIL/NOSWITCH	DISC/NOSWITCH
1	OK	CONNECTED
2	OK	CONNECTED
3	OK	CONNECTED
4	OK	CONNECTED
5	FAIL/NOSWITCH	DISC/NOSWITCH
6	FAIL/NOSWITCH	DISC/NOSWITCH
7	FAIL/NOSWITCH	DISC/NOSWITCH
8	FAIL/NOSWITCH	DISC/NOSWITCH
9	FAIL/NOSWITCH	DISC/NOSWITCH
10	FAIL/NOSWITCH	DISC/NOSWITCH
11	FAIL/NOSWITCH	DISC/NOSWITCH

```

|_|_|_|_|_|_|_|_|
|d|i|g|i|t|a|l|
|_|_|_|_|_|_|_|_|
```

FCO DS-650Q8-F001

PAGE 13 OF 15

MIRA TESTING PROCEDURE UNDER VMS (continued)

MIRA> SWAP

```
MIRA> SHO
Local System State      : STANDBY Remote System State      : MASTER
Dc Low State           : DISABLED
Local Timer Value      : .3 s
```

```
Module  Module State      Switch Map
 0      DISC/NOSWITCH     UNASSIGNED
 1      DISCONNECTED     SAME
 2      DISCONNECTED     SAME
 3      DISCONNECTED     SAME
 4      DISCONNECTED     SAME
 5      DISC/NOSWITCH     UNASSIGNED
 6      DISC/NOSWITCH     UNASSIGNED
 7      DISC/NOSWITCH     UNASSIGNED
 8      DISC/NOSWITCH     UNASSIGNED
 9      DISC/NOSWITCH     UNASSIGNED
10      DISC/NOSWITCH     UNASSIGNED
11      DISC/NOSWITCH     UNASSIGNED
Total Connected: 0      Total Assigned: 4
```

```
MIRA> TEST
```

```
Local loop test      : OK
Remote loop test     : OK
Watchdog link connected
Switching box 0 connected
Switching box 1 not connected
Front panel connected
Alarm I/O panel connected
```

```
Module  Test              Status
 0      FAIL/NOSWITCH     DISC/NOSWITCH
 1      OK                 DISCONNECTED
 2      OK                 DISCONNECTED
 3      OK                 DISCONNECTED
 4      OK                 DISCONNECTED
 5      FAIL/NOSWITCH     DISC/NOSWITCH
 6      FAIL/NOSWITCH     DISC/NOSWITCH
 7      FAIL/NOSWITCH     DISC/NOSWITCH
 8      FAIL/NOSWITCH     DISC/NOSWITCH
 9      FAIL/NOSWITCH     DISC/NOSWITCH
10      FAIL/NOSWITCH     DISC/NOSWITCH
11      FAIL/NOSWITCH     DISC/NOSWITCH
```

```
MIRA> EXIT
```

Do not forget to reactivate the MIRA start into the SYSTARTUP files if you have modified these files.

***** END OF TEST SYSTEM IS READY FOR APPLICATION USE *****



MIRA SWITCH SETTINGS

M7764-00 DISPATCHER MODULE (SWITCH LOCATION E5)

Main Cabinet (Switching Box 0)

	3		2		1		0		Bit
	ON		OFF		OFF		OFF		Switch Setting Main Cabinet
	E5		E5		E5		E5		Switch Number
	1		2		3		4		

Expansion Cabinet (Switching Box 1)

	3		2		1		0		Bit
	OFF		ON		OFF		OFF		Switch Setting Main Cabinet
	E5		E5		E5		E5		Switch Number
	1		2		3		4		

M7763-00 WATCHDOG MODULE

Vector Address location E24 example (400)

MSB	Bit	15	14	13	12	11	10	9	8	7	6	5	4	3	2	1	0	LSB
Switch								E24	E24	E24	E24	E24	E24	E24				
								1	2	3	4	5	6	7				
								OFF	ON	OFF	OFF	OFF	OFF	OFF				

CSR Address location E33 example (767000)

MSB	Bit	15	14	13	12	11	10	9	8	7	6	5	4	3	2	1	0	LSB
Switch					E33	E33	E33	E33	E33	E33	E33	E33	E33	E33				
					1	2	3	4	5	6	7	8	9	10				
					OFF	ON	ON	ON	OFF	OFF	OFF	OFF	OFF	OFF				

_	_	_	_	_	_	_	_	_
d	i	g	i	t	a	l		
_	_	_	_	_	_	_	_	_

FCO DS-650Q8-F001

PAGE 15 OF 15

LARS

CATEGORY F	USA	GIA	EUROPE
Activity -			
(a)Contract and Warranty	W	U	Y
(b)IN-DEC Contract	K		
Hardware Segment Code	111		
Non Contract/Non Warranty	F	F	F
(c)RTD/Off-site Agreement	F		
Product Line	16		
DEC Option	DS-650Q8-XX	DS-650Q8-XX	DS-650Q8-XX
Type of Call	M	M	M
Action Taken	D	D	I
Fail Area-Module-FCO-Comments	MIRA-F001	MIRA-F001	MIRA-F001
Material Used	EQ-01568-02	EQ-01568-02	EQ-01568-02

- (a) Warranty Optimum, Warranty Standard and Warranty Basic (on-site) Agreements.
- (b) Applies to INDEC AREA ONLY - Warranty Optimum, Warranty Standard and Warranty Basic (on-site) Agreements.
- (c) RTD=Return to Digital or Off-site Agreements; If Field Engineer On-site, use Activity Code "F".

\^ 650Q8
\650Q8
\DS-650Q8
\CHALUMEAU
\1990
\APR
\FCO_DOCS