

Application Note 5360

SFP+ Evaluation Board

The purpose of this SFP+ evaluation board is to provide the designer with a convenient means for evaluating SFP+ fiber optic transceiver such as AFBR-700SDZ and AFBR-57D5APZ compliant with MSA SFF-8074i or SFF-8472. This document describes the details of the evaluation printed circuit board and the test methods for evaluating SFP+ modules.

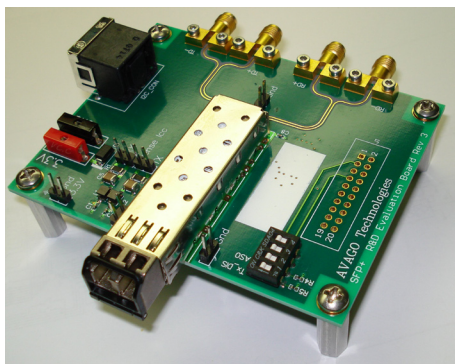

I. Equipment List included in the evaluation board kit AFCT-5016Z

1. SFP+ Evaluation PCB
2. DC Power supply cable assembly

II. Equipment List not included in this kit

1. 3.3V DC power supply
2. Fiber optic cables
3. DCA-J 86100C
4. DCA-J plug in 86105C, 86112A
5. Error Performance Analyzer, Pattern Generator 70843B
6. Fiber optic attenuator
7. EEPROM Reader(i-Port or similar), RJ-45 cable
8. PC

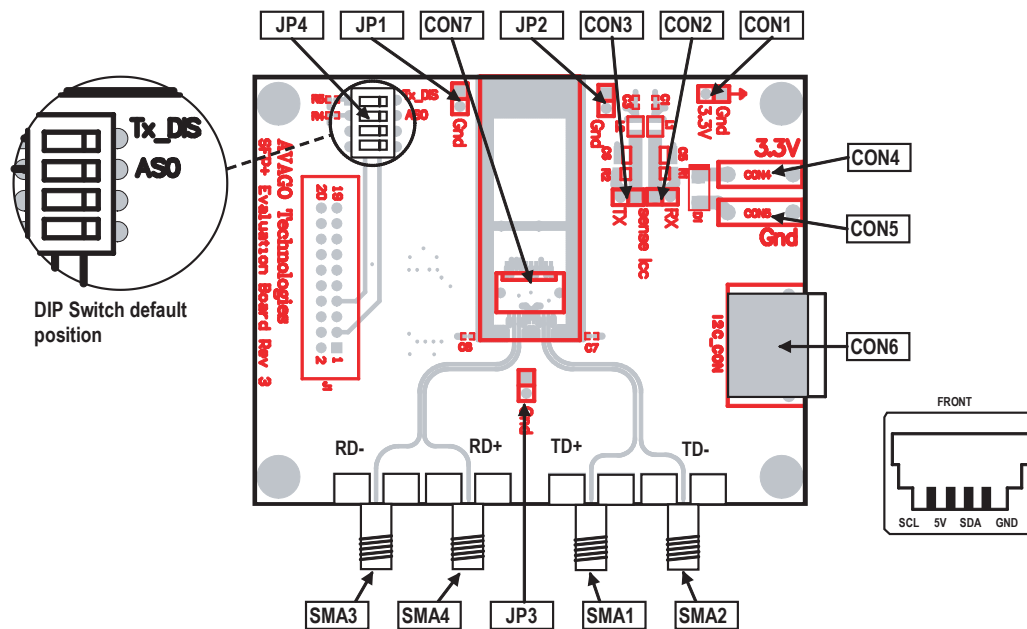

Figure 1. SFP+ Evaluation Board Top Views

III. SFP+ Evaluation board description

Top view of the evaluation PCB is shown in Figure 1. TX_Disable and ASO pins should be grounded by default using DIP switch (JP4) setting as shown in the diagram. Apply 3.3V power supply to CON4 with CON5 GND. CON2 and CON3 can be used to monitor the current to SFP module RXVCC and TXVCC supplies respectively. Measure the voltages and divide by 0.05 ohm sensing resistors. Use CON6 to access the SFP module two wire serial signals, SCL and SDA. JP1, JP2 and JP3 are all tied to the evaluation board common circuit GND.

A description of all of the i/o interfaces on the PCB is shown in Table 1. The evaluation board is a 6-layer design with Nelco N4000-13 core material.

Table 1. I/O description

Reference Designator	Name	Description	Signal Level
SMA1	TD+	Differential Transmitter Input	Note 1
SMA2	TD-		
SMA3	RD-	Differential Receiver Output	Note 1
SMA4	RD+		
CON1	EXT_SUPPLY	3.3V External Power supply	Note 1
CON2	RX sense	RX ICC current sense	Rsense=50m ohm
CON3	TX sense	TX ICC current sense	Rsense=50m ohm
CON4	EXT_SUPPLY	3.3V External Power supply	Note 1
CON5	GND	GND	GND
CON6	I2C_CON	2 wire serial interface, SCL & SDA	LVTTL *
CON7	SFP+ 20pin connector	SFP+ Module plugs here	
JP1	GND	TX and RX common GND	GND
JP2	GND		
JP3	GND		
JP4	DIP SWITCH	TX_Disable and ASO GNDed when switch is at 'ON' position, pulled up to TX VCC when in 'OFF' position.	LVTTL *

Notes

1. See specific transeiver data sheet for recommended operating voltages and further information
2. * LVTTL defines a 3.3V level with transitions at 0.8 and 2.0V

IV. Electro-Optical Test Configurations

A basic test configuration for evaluating the SFPs is shown in Figure 2. SFP's TX & RX optical/electrical characteristics such as eye diagram, rise/fall time, jitter can be tested. It is recommended that low loss, low dispersion and matched equal length RF cables be used to connect TD+/- and RD+/- signals to the test equipment. Representative TX and RX eye diagrams for a SFP are shown in Figure 3 and 4.

V. EEPROM Test Configuration

The SFP+ MSA specifies an EEPROM internal to the transceiver. The standard two wire serial protocol can be implemented to allow the user to read/write the user accessible area in the EEPROM by using the MOD_DEF(1), MOD_DEF(2) and GND connections on the Evaluation board. MOD_DEF(1) and MOD_DEF(2) are equal to SCL and SDA respectively as shown in the Figure 1 connector illustration.

For more information about Avago Technologies SFP+ transceiver products, please contact your local sales representative or visit us at www.avagotech.com

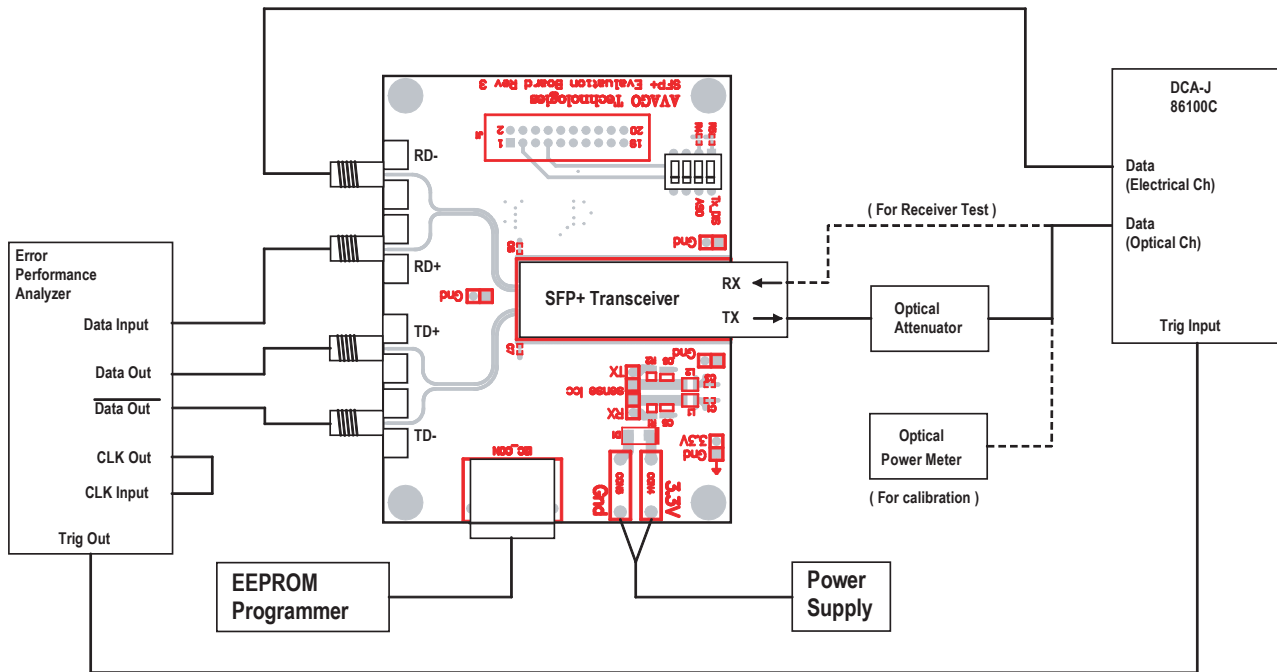

Figure 2. Basic Test Configuration of SFP+ module

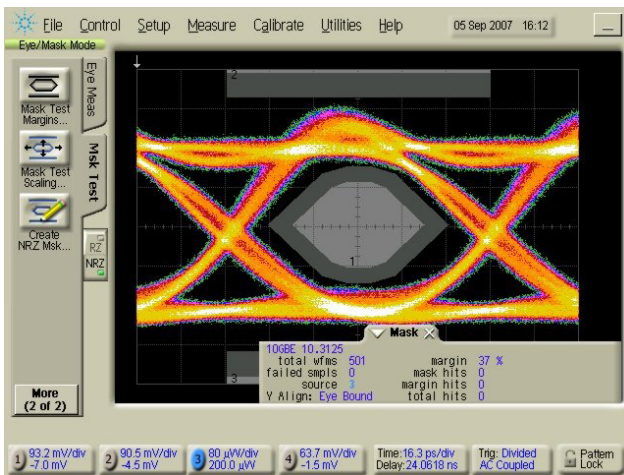

Figure 3. TX Eye diagram

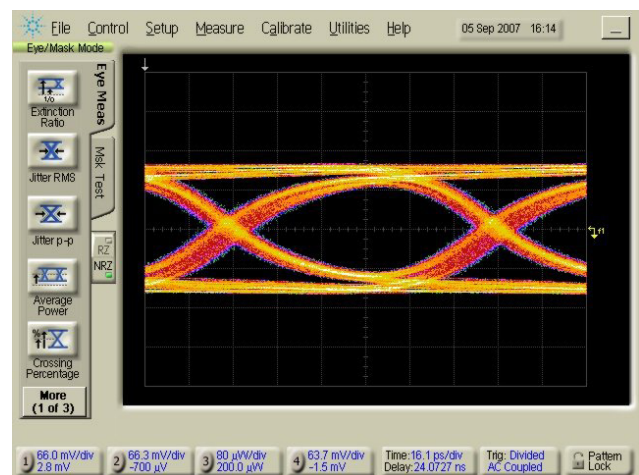

Figure 4. RX Eye diagram.

VI. Evaluation Board Schematic and Bill of Materials

The SFP+ evaluation board schematic is shown in Figure 3. Not all components in the schematic are fitted on the evaluation board. They are for optional functionality of the board. Table 2 shows the bill of materials.

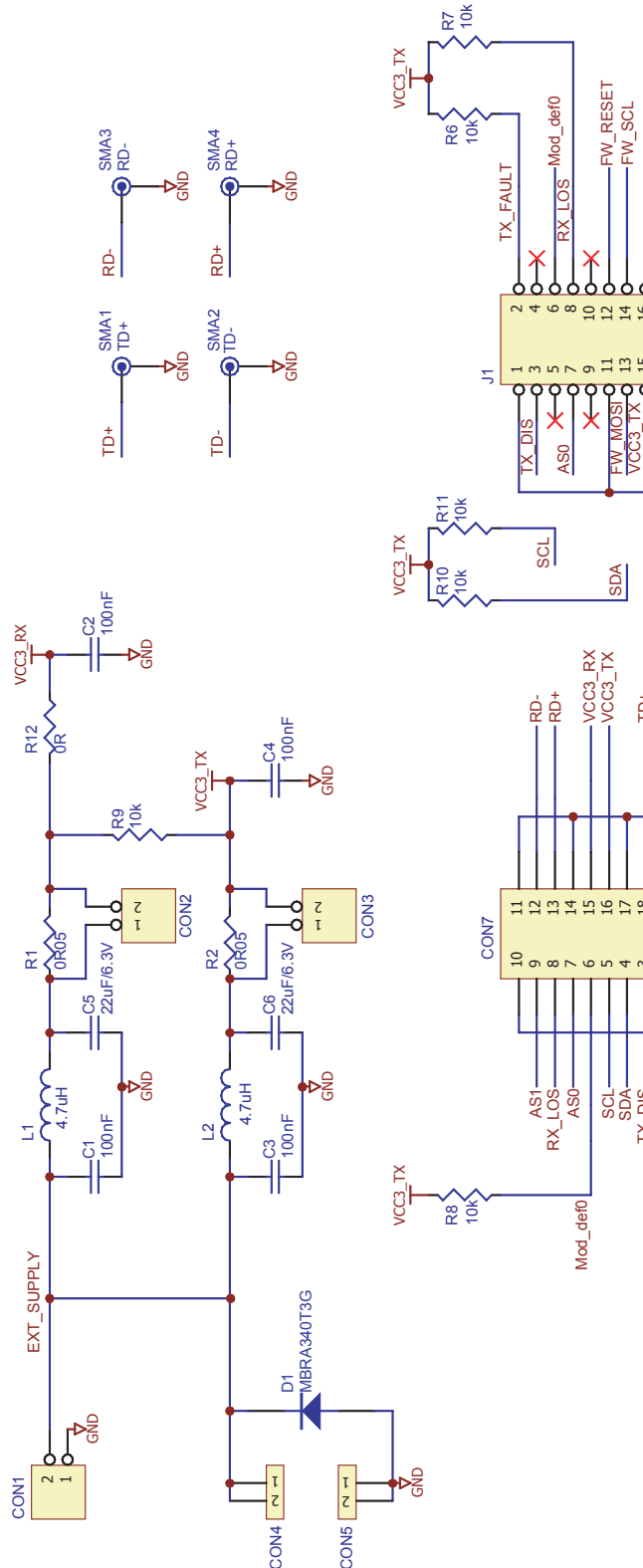

Figure 5. SFP+ Evaluation Board Schematics

VII. References

1. AFBR-700SDZ, AFBR-57D5APZ Product Data Sheets
2. SFF Committee SFF-8431, SFF-8472
3. AFBR-700SDZ(SR), AFBR-707SDZ(LRM), AFCT-701SDZ(LR) Product data sheets.
4. Application Note "PCB Layout Guidelines for Designing with Avago SFP+ Transceivers" AV02-0725EN

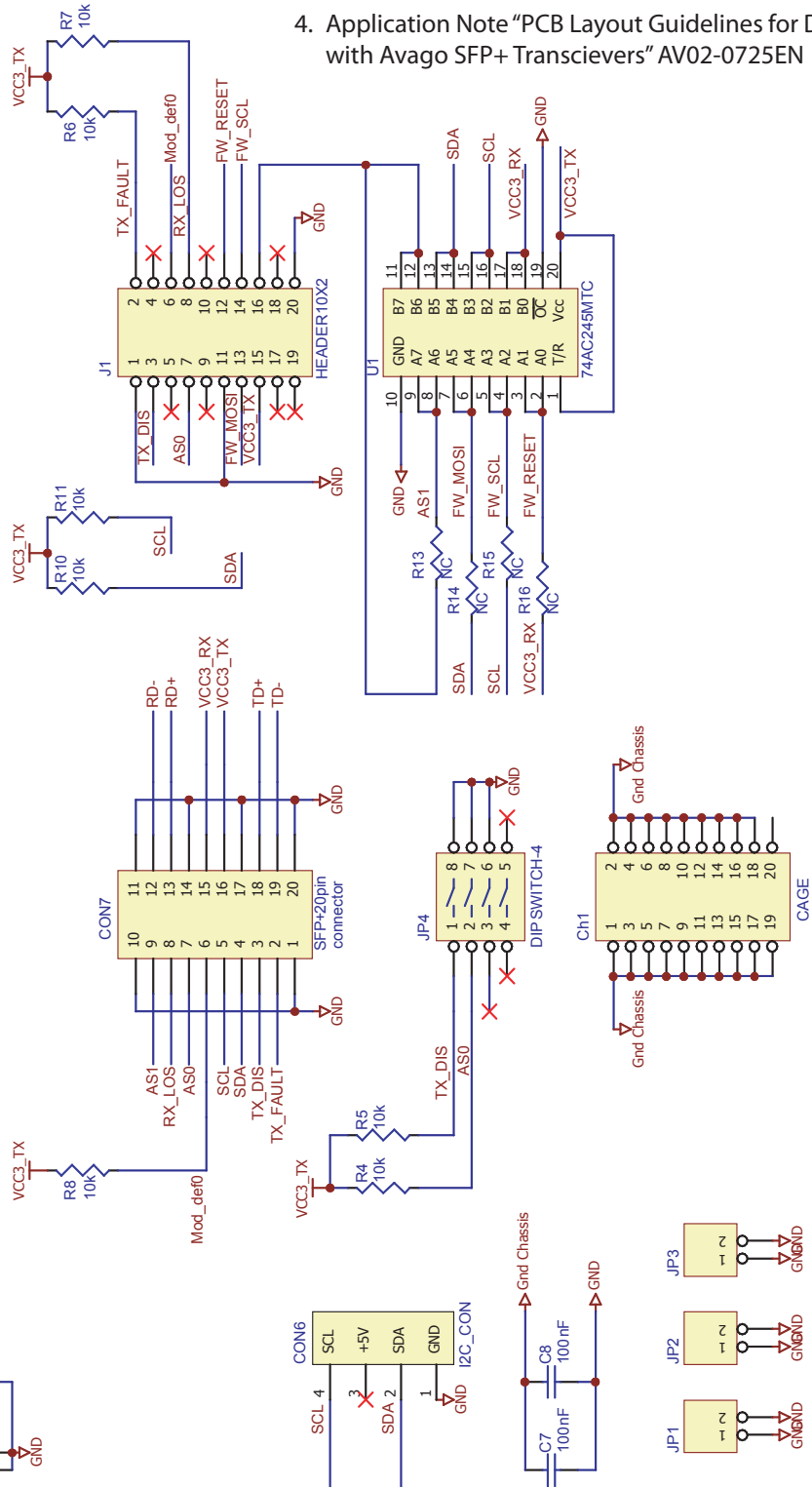

Table 2. SFP+ Evaluation Board Bill of Materials

Part Type	Designator	Footprint	Description
OR05	R2	1206PCB	
OR05	R1	1206PCB	
OR	R12	0402-2	
4.7uH	L2	LQH32	Inductor
4.7uH	L1	LQH32	Inductor
10k	R9	0402-2	
10k	R11	0402-2	
10k	R5	0402-2	
10k	R4	0402-2	
10k	R7	0402-2	
10k	R8	0402-2	
10k	R10	0402-2	
10k	R6	0402-2	
22uF-6.3V	C5	1210PCB	Capacitor
22uF-6.3V	C6	1210PCB	Capacitor
100 nF	C7	0402-2	Capacitor
100 nF	C8	0402-2	Capacitor
100 nF	C2	0402-2	Capacitor
100 nF	C3	0402-2	Capacitor
100 nF	C1	0402-2	Capacitor
100 nF	C4	0402-2	Capacitor
Banana BLACK	CON5	TESTP	
Banana RED	CON4	TESTP	
CHASSIS	Ch1	SFP+ CHASSIS	
DIP SWITCH-4	JP4	DIP8	DIP switch
HEADER	CON3	SIP2	
HEADER	CON1	SIP2	
HEADER	CON2	SIP2	
HEADER	JP3	SIP2	
HEADER	JP2	SIP2	
HEADER	JP1	SIP2	
I2C_CON	CON6	I2C_CON	I2C connector, Tyco P/N 4-1761206-1, Molex P/N 15-83-0064
MBRA340T3G	D1	SOD-106	
RD+	SMA4	SMA_ROSENBERGER	SMA Connector 32K243-40ME3
RD-	SMA3	SMA_ROSENBERGER	SMA Connector 32K243-40ME3
SFP+ 20pin connector	CON7	SFF CONN	Molex, SFP Plus connector, P/N/ 7441-0010
TD+	SMA1	SMA_ROSENBERGER	SMA Connector 32K243-40ME3
TD-	SMA2	SMA_ROSENBERGER	SMA Connector 32K243-40ME3

For product information and a complete list of distributors, please go to our web site: www.avagotech.com

Avago, Avago Technologies, and the A logo are trademarks of Avago Technologies, Limited in the United States and other countries. Data subject to change. Copyright © 2007 Avago Technologies Limited. All rights reserved.
AV02-0720EN - October 9, 2007