

MS9720A

WDM Network Tester

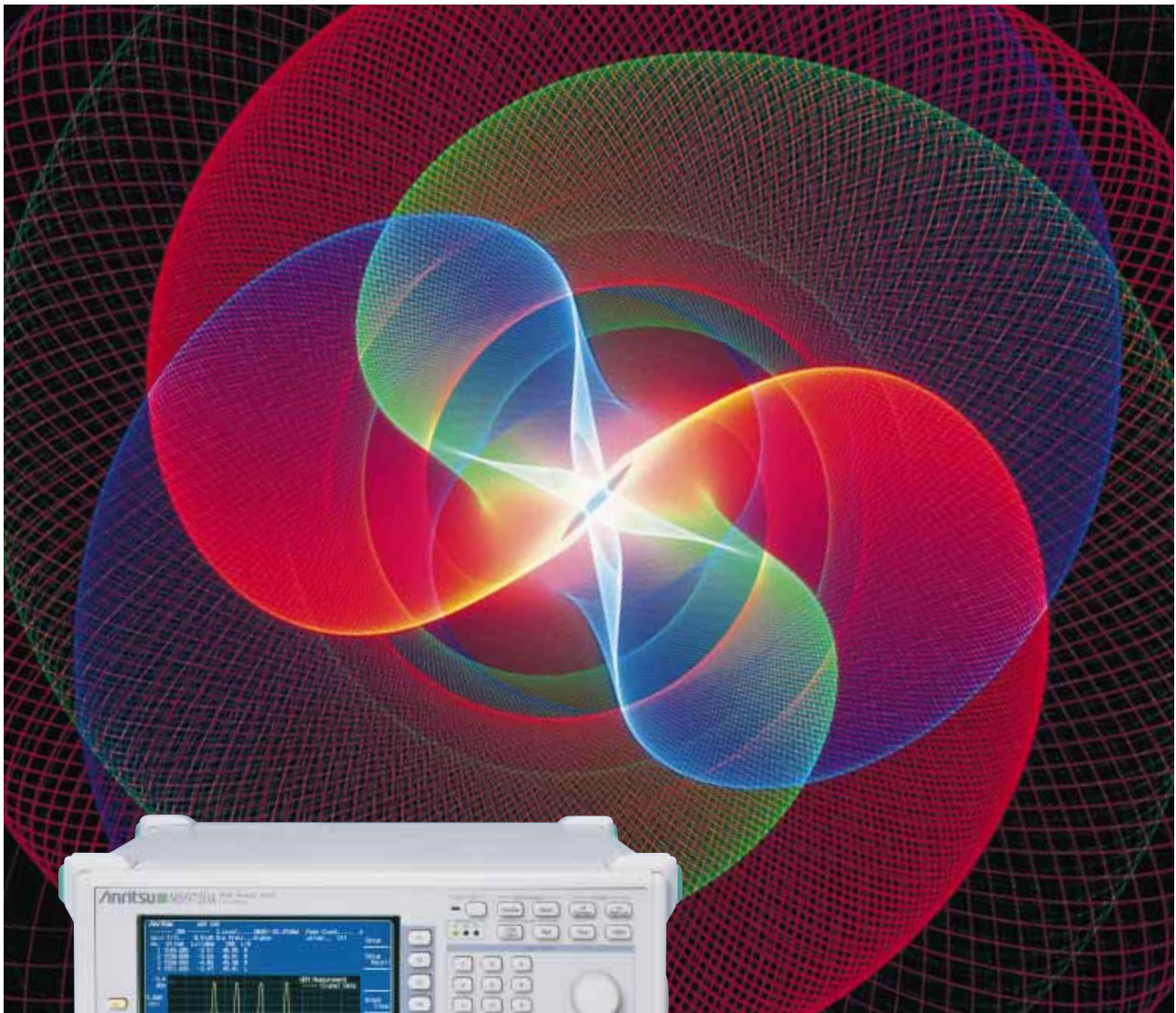

*High-Performance
WDM Measurement*

Ideal for High-Performance WDM Measurement

From R&D and production to installation and maintenance of WDM communications devices

- ± 20 pm Wavelength Accuracy (Reference Optical Source Built-in)
- 58 dB Dynamic Range (1 nm from Signal Wavelength)
- -87 dBm Optical Reception Sensitivity
- Three Memories, Three Traces, Split Screen
- Full Line-up of Functions and Applications
- VGA Output Connector



The MS9720A is an optical spectrum analyzer with a diffraction grating that is used to measure and analyze optical spectra in the 1450 to 1650 nm band for WDM communications systems.

In addition to having excellent basic performance such as high wavelength accuracy, wide dynamic range and good optical reception sensitivity ideally suited to measurement and analysis of the optical spectra used in WDM communications, it also has a full line-up of functions matching a wide range of needs ranging from manufacturing of WDM communications devices, to installation and maintenance.

± 20 pm Wavelength Accuracy with Built-in Light Source

A wavelength accuracy of ± 20 pm is achieved over a range of 1530 to 1570 nm by performing calibration using the built-in wavelength reference light source. Wavelength calibration is performed automatically just by pressing the Cal key, permitting accurate measurement of the absolute wavelength value required in evaluation of WDM systems. Calibration of the absolute wavelength value uses the absorption spectrum of acetylene. The block diagram of the calibration light source is shown below. In addition, the output of the built-in SLD light source can be used for evaluating the transmission characteristics of passive elements

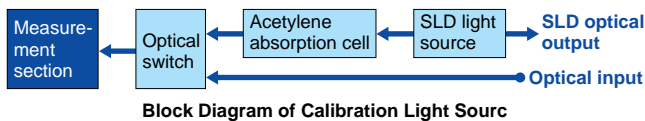

Three Memories, Three Traces, Split Screen

Up to three memories can be used for measurement; the results found by mathematically processing the data in these three memories can be displayed as up to three traces on the screen. Furthermore, by using the split screen function, it is possible to simultaneously display two sets of measurement data on the screen as well as the difference between the two sets of data.

The following screen shows a measurement of filter characteristics; the top half of the split screen shows the reference light and the measured optical spectrum while the bottom half shows the spectrum of the measured light minus the reference light.

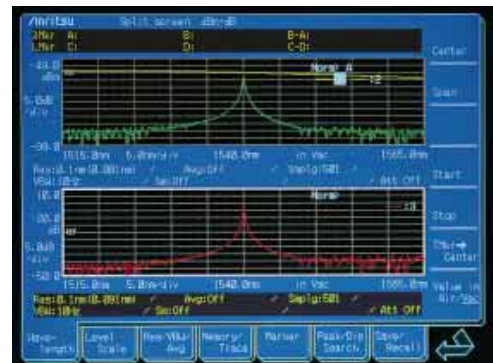

58 dB Dynamic Range

The measurement dynamic range at the wavelength 1 nm from the peak is 58 dB demonstrating the tester's power when measuring the SNR of light sources in WDM systems and when evaluating filters, etc. The following screens show the dynamic range at 1 and 0.5 nm from the peak.

Dynamic range	58 dB (1 nm from peak)
	53 dB (0.5 nm from peak)

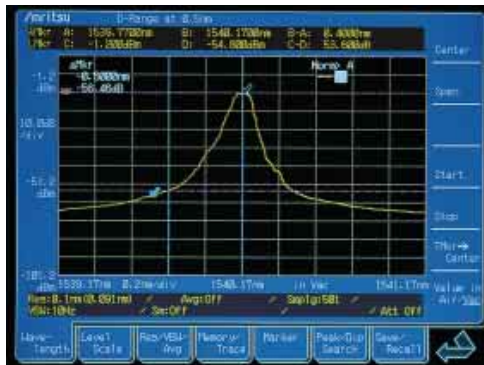
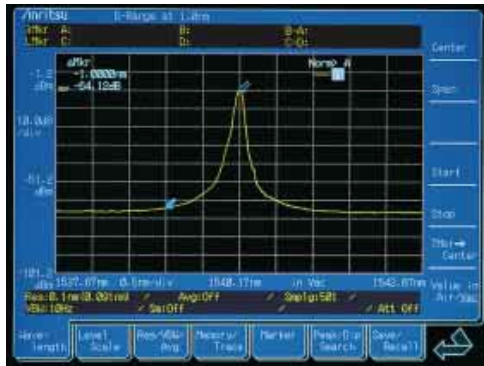

-87 dBm Optical Reception Sensitivity

The MS9720A noise level is -87 dBm, so the tester is ideal for measuring the SNR of light sources used in WDM systems, as well as optical leakage and reflected light. The following screen shows a measurement of an optical spectrum of a DFB LD with the output level attenuated to -85 dBm at a VBW of 10 Hz.

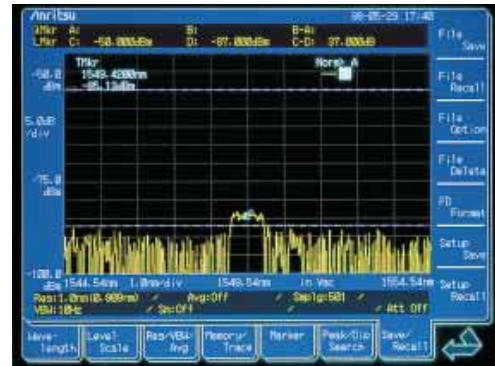

The SNR is improved by using averaging processing. The following is an example of measurement result after 10 sweep averaging are performed.

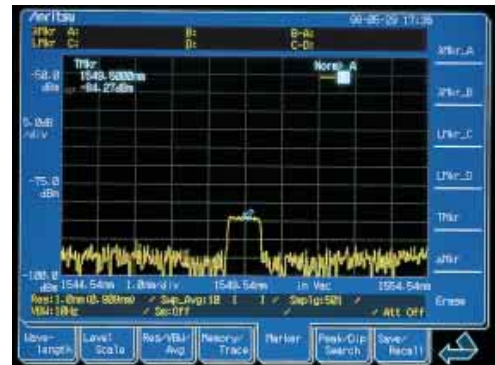

Full Line-up of Functions and Applications

In addition to its excellent basic performance, the MS9720A has a full line-up of useful functions. The basic waveform analysis functions offer applications for evaluating every important item in WDM systems.

Waveform analysis	Threshold analysis, SMSR analysis, spectrum power (integrated power calculation)
Applicable measurement	Insertion loss, isolation, directivity, return loss, polarized mode dispersion (PMD), fiber amplifier noise figure (NF), WDM wavelength analysis, long-term measurement

The following screens show threshold and SNR analysis of a WDM signal waveform. The effective analysis range is set using the Zone Marker even for WDM signals, enabling independent analysis of the waveform of each channel.

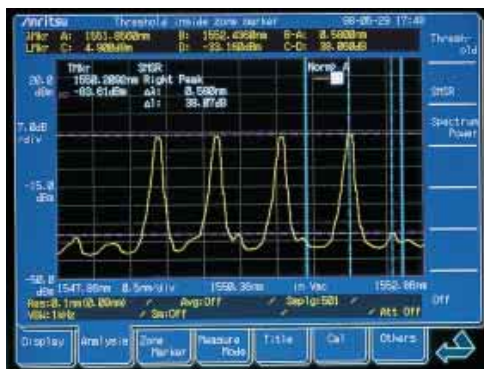
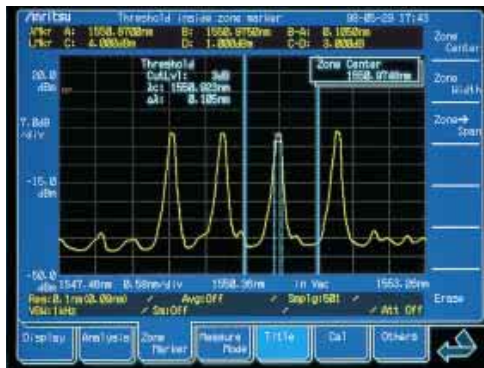

Insertion Loss Measurement

At insertion loss measurement, the insertion loss of optical devices such as optical couplers can be measured. The following screen shows a measurement of the transmission characteristics of a band pass filter.

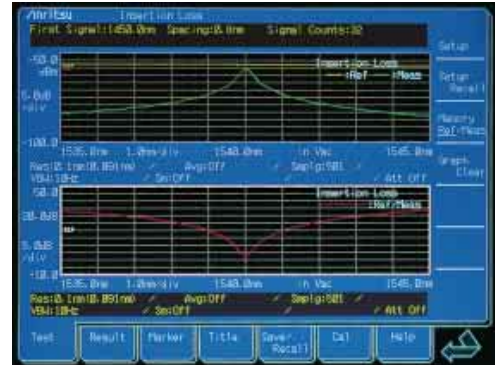

In addition, the measurement results for a specified WDM channel wavelength can be displayed as a list.



The following diagrams show the setup when measuring the insertion loss of a WDM coupler using the built-in SLD, or an external light source.

Reference Measurement

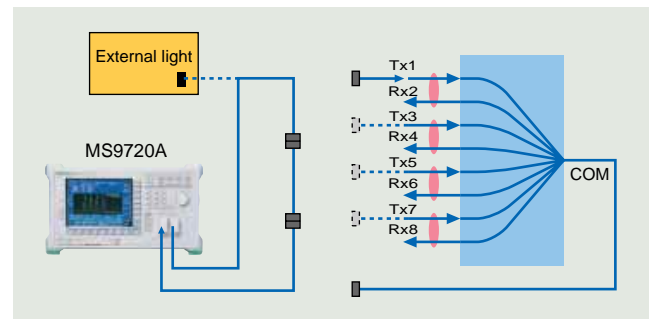

Insertion Loss Measurement

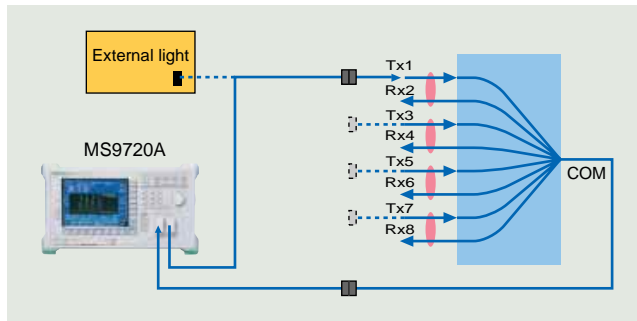

By using the same setup, it is possible to measure the optical leakage between each channel of an optical coupler and to measure the isolation. Moreover, when used in combination with an external light source, it is possible to measure the directivity to evaluate the very weak optical leakage between send and receive channels.

Isolation Measurement

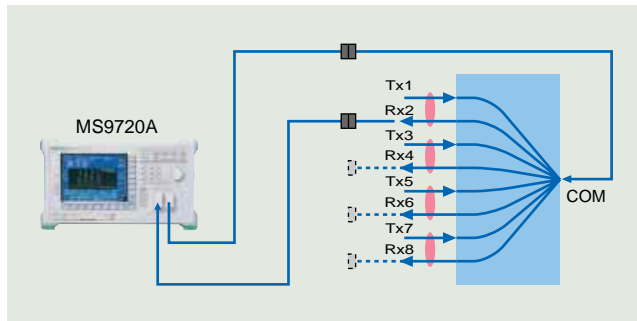

Help Function

All the measurement procedures and set ups for applications are explained by easy-to-understand diagrams that are displayed by pressing the Help key.

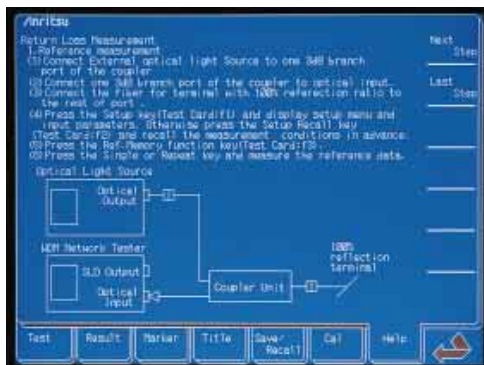

Return Loss Measurement

When the MS9720A is combined with the dedicated MN9604C Optical Directional Coupler (sold separately) and the total reflection optical fiber (sold separately), the return loss can be measured.

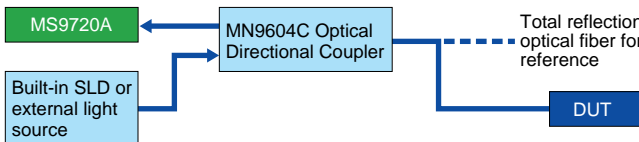

The following screens show a measurement of the reflection at the fiber input end (open) using a four-wave WDM light source as the external light source.

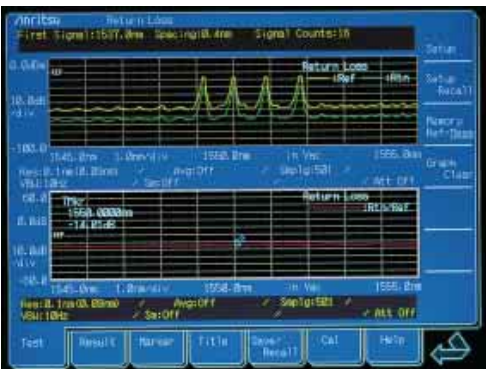

No.	Signal Wavelength	Reflection Level	Reference Level	Return Loss
1	1540.000nm	-6.00dB	-20.15dB	-14.07dB
2	1540.800nm	-6.01dB	-20.05dB	-14.14dB
3	1550.000nm	-6.04dB	-20.00dB	-14.07dB
4	1550.800nm	-6.70dB	-20.07dB	-14.17dB

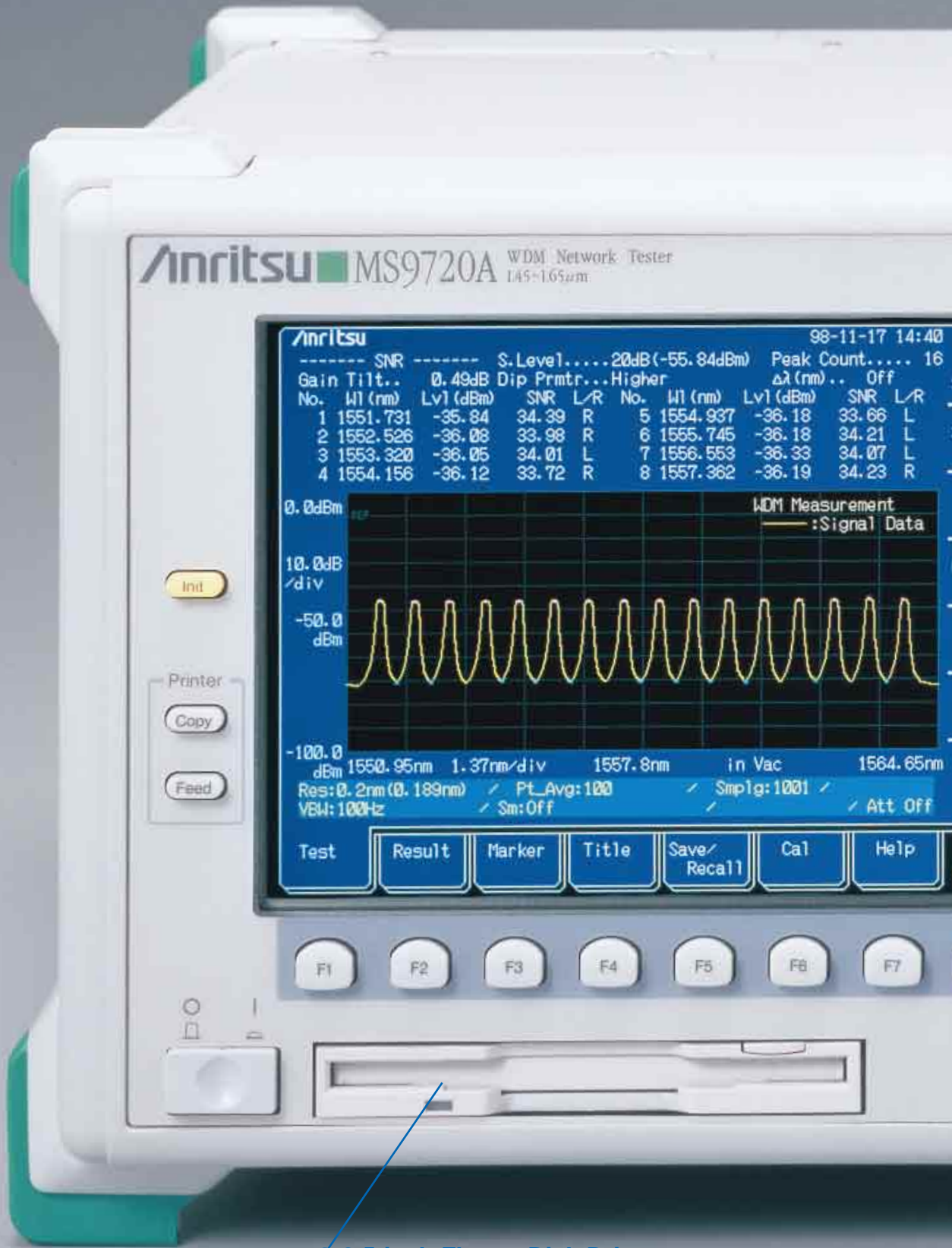

● **3.5-inch Floppy Disk Drive**

In addition to saving and recalling data to and from FD, waveform images saved on FD can be viewed on a personal computer screen. The MS9720A can save waveform images to FD as either Windows bitmapped files or text files. Moreover, the data can be exported easily into word processing and spreadsheet software applications.

*The photograph is nearly actual size.



● **Optical Input Connectors**

Any of FC-PC, DIN, ST, SC, HMS-10/A or E2000 connectors can be used. Cleaning is easy because the connector can be removed and refitted (except E2000).

● **SLD Output**

The MS9720A has an SLD light source which is very useful for evaluating the transmission characteristics of WDM devices.

Long-Term Measurement

The MS9720A has a long-term measurement function for displaying the wavelength, level and SNR, etc., as a table, and saving the measurement to floppy disk as a text file at a set measurement interval. During long-term measurement, wavelength calibration is performed every 6 hours, and level calibration every 1 hour.



NF Measurement

The MS9720A can measure NF using interpolation technic (level fitting method). In the MS9720A NF measurement function, the ASE (Amplified Spontaneous Emission) is calculated by the averaging the sum of the level at two points separated by a fixed wavelength from the signal wavelength of the EDFA output. The following screens show a measurement of the NF of an EDFA amplifying a WDM signal.

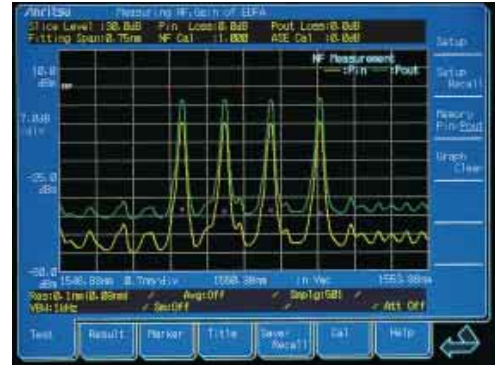

PMD Measurement

It is also possible to measure the PMD (Polarization Mode Dispersion), an important factor determining the upper limit of the transmission bit rate in optical fiber amplifier systems. The MS9720A has a function for calculating PMD using a fixed analyzed method which is one measurement method. The PMD can be measured easily by using the following type of measurement system.

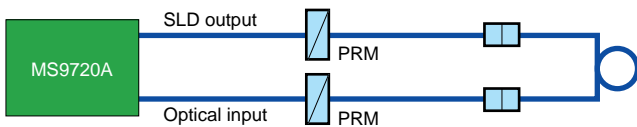

PRM: Polarization rotation module (sold separately)

The diagram below shows PMD measurement of a 1 m PANDA fiber.

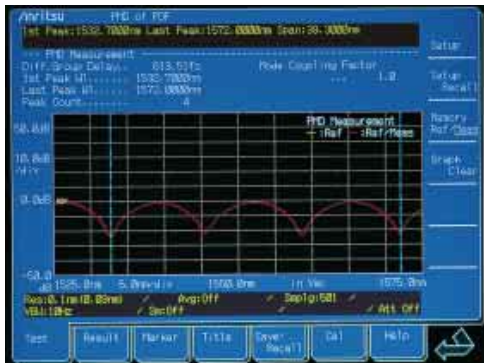

WDM Waveform Analysis

A major problem of WDM transmission systems is the signal-to-noise ratio (SNR) of each signal channel. Quantitative measurement and evaluation of SNR is extremely important in WDM transmission systems. The MS9720A can analyze up to 128 WDM waveforms and display the peak wavelength, level and SNR of each channel.

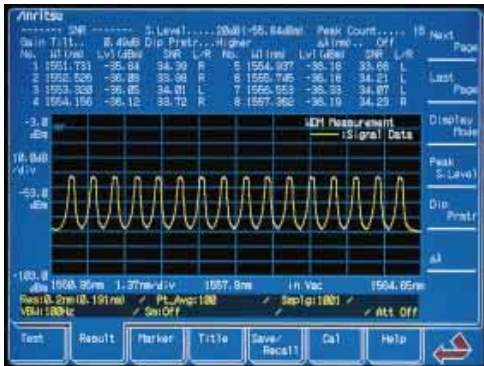

The screen below shows analysis of a 16-channel WDM waveform; the level difference of each channel is displayed using the channel on the left side as a reference. Any channel can be set as the reference.

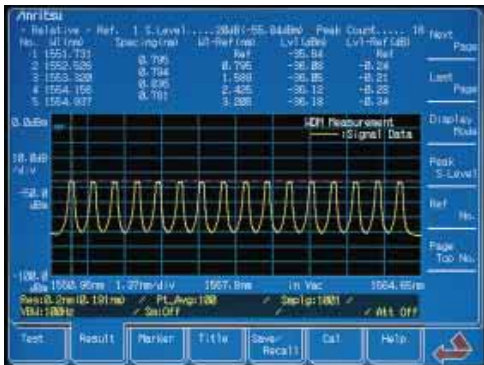

Wide-Bandwidth, High-Output SLD Light Source

The following screen shows the output spectrum of the SLD from 1450 to 1650 nm. At 1550 nm and a resolution of 1 nm, the output level is -40 dBm min. A dynamic range of approx. 50 dB can be measured with setting the VBW 10 Hz.



VGA Output Connector

A VGA output connector is provided on the rear panel of the MS9720A for displaying the measurement screen on a PC monitor.



Specifications

Applicable fiber	10/125 μm SM fiber (ITU-T G.652)
Optical connector	User replaceable (FC, SC, ST, DIN, HMS-10/A), Factory option (E2000, FC-APC, SC-APC, HRL-10)
Wavelength	<p>Range: 1450 to 1650 nm</p> <p>Accuracy: ± 20 pm (1550 ± 20 nm, room temperature), ± 50 pm (1520 to 1600 nm), ± 0.3 nm (all range) *After wavelength calibration</p> <p>Stability: ± 5 pm (smoothing: 11 pt, 1 minute, at half-width of center wavelength)</p> <p>Linearity: ± 20 pm (1550 ± 20 nm)</p> <p>Read resolution: 5 pm (display resolution: 1 pm)</p> <p>Setting resolution: 0.1, 0.2, 0.5, 1.0 nm (filter: 3 dB bandwidth)</p> <p>Resolution accuracy: $\leq \pm 10\%$ (1550 ± 20 nm, 0° to 30°C), $\leq 30\%$ (1550 ± 100 nm, 0° to 30°C)</p>
Level	<p>Measurement level ranges:</p> <ul style="list-style-type: none"> -87 to +10 dBm (1450 to 1600 nm, 0° to 30°C), -72 to +10 dBm (1600 to 1650 nm, 0° to 30°C), -82 to +10 dBm (1450 to 1600 nm, 30° to 50°C), -67 to +10 dBm (1600 to 1650 nm, 30° to 50°C), -68 to +23 dBm (1450 to 1600 nm, 0° to 30°C, internal optical attenuator: on) <p>Accuracy: ± 0.4 dB (1550 nm, -23 dBm)</p> <p>Stability: ± 0.02 dB (1550 nm, -23 dBm, 1 minute, constant temperature, no polarization fluctuation)</p> <p>Linearity: ± 0.05 dB (1550 nm, -50 to 0 dBm)</p> <p>Flatness: ± 0.1 dB (1550 ± 20 nm), ± 0.3 dB (1520 to 1600 nm)</p>
Polarization dependency	± 0.15 dB
Dynamic range	58 dB (at point 1 nm from peak), 53 dB (at point 0.5 nm from peak)
Optical return loss	35 dB (1550 nm)
SLD output	> -40 dBm/nm (at 1550 nm)
Display	6.4-inch color TFT-LCD
Memory trace	Three measurement memories and three trace displays
Printer	Internal (thermal type)
Interface	GPIB, RS-232C, monitor output (VGA compatible)
Data save/output	3.5-inch floppy disk drive
Ambient conditions	<p>Operating temperature: 0° to +50°C (however, 5° to 50°C for FDD)</p> <p>Storage temperature: -20° to +60°C</p> <p>Relative humidity: $\leq 90\%$ (no condensation, 20% to 80% for FDD)</p>
Power	85 to 132 Vac/172 to 250 Vac, 47.5 to 63 Hz, 150 VA (max.)
Dimensions and mass	320 (W) \times 177 (H) \times 350 (D) mm (excluding projections), ≤ 16.5 kg

Note: Warm-up to the MS9720A for about 5 minutes to ensure stable operation. The above specifications are obtained at 2-hours after power-on.

Ordering Information

Please specify the model/code, name and quantity when ordering.

Model/Order No.	Name	Remarks
MS9720A	Main frame WDM Network Tester	
	Standard accessories	
	Optical connector adaptor*1: 1 pc	
F0012	Fuse, 3.15 A: 2 pcs	For 100 Vac
F0010	Fuse, 1.6 A: 2 pcs	For 200 Vac
W1343AE	MS9720A operation manual: 1 copy	
W1344AE	MS9720A remote control operation manual: 1 copy	
	Power cord, 2.6 m: 1 pc	
B0329G	Front cover: 1 pc	3/4MW4U
Z0312	Printer paper: 2 rolls	
MX972001S	LabVIEW® Driver (RS-232C): 1 pc	
MX972001G	LabVIEW® Driver (GPIB) 1 pc	
	Options	
MS9720A-27	E2000 (DIAMOND) connector	Factory option
MS9720A-31	EC (RADIAL) connector	Factory option
MS9702A-37	FC connector	
MS9720A-38	ST connector	
MS9720A-39	DIN connector	
MS9720A-40	SC connector	
MS9720A-43	HMS-10/A (DIAMOND) connector	
MS9720A-47	HRL-10 connector	Factory option
	Application parts	
MN9604C	Optical Directional Coupler	
J0654A	Serial interface cable	IBM-PC/AT, J-310 (remote control)
J0655A	Serial interface cable	9P-25P
J0007	GPIB cable, 1 m	408JE-101
J0617B	Replaceable connector(FC)	
J0618D	Replaceable connector (ST)	
J0618E	Replaceable connector (DIN)	
J0618F	Replaceable connector (HMS-10/A)	
J0619B	Replaceable connector (SC)	
J0635B	Optical fiber cord (FC•PC-FC•PC-2M-SM), 2 m	
J0441	Total internal reflection fiber cord	
Z0282	Replacement reel for ferrule cleaner	Kuretop A type
Z0283	Ferrule cleaner spare tape	For Z0282, 6 pcs/set
Z0284	Adapter cleaner	Stick type, 200 pcs/set
B0330C	Tilt bail	
B0336C	Hard carrying case	
G0084A	Polarization rotation module	

*1: Specify the connector to be supplied as the standard connector when ordering the above options.
If the connector is not specified, the FC connector (MS9720A-37) is supplied as standard.



Specifications are subject to change without notice.

ANRITSU CORPORATION

5-10-27, Minamiazabu, Minato-ku, Tokyo 106-8570, Japan
Phone: +81-3-3446-1111
Telex: J34372
Fax: +81-3-3442-0235

Overseas Subsidiaries

● **U.S.A.**

ANRITSU COMPANY

North American Region Headquarters

1155 East Collins Blvd., Richardson, Tx 75081, U.S.A.
Toll Free: 1-800-ANRITSU (267-4878)
Phone: +1-972-644-1777
Fax: +1-972-671-1877

● **Canada**

ANRITSU ELECTRONICS LTD.

Unit 102, 215 Stafford Road West
Nepean, Ontario K2H 9C1, Canada
Phone: +1-613-828-4090
Fax: +1-613-828-5400

● **Brasil**

ANRITSU ELETRÔNICA LTDA.

Praia de Botafogo 440, Sala 2401 CEP 22250-040,
Rio de Janeiro, RJ, Brasil
Phone: +55-21-5276922
Fax: +55-21-537-1456

● **U.K.**

ANRITSU LTD.

200 Capability Green, Luton, Bedfordshire LU1 3LU, U.K.
Phone: +44-1582-433200
Fax: +44-1582-731303

● **Germany**

ANRITSU GmbH

Grafenberger Allee 54-56, 40237 Düsseldorf, Germany
Phone: +49-211-96855-0
Fax: +49-211-96855-55

● **France**

ANRITSU S.A.

9, Avenue du Québec Z.A. de Courtabœuf 91951 Les
Ulis Cedex, France
Phone: +33-1-60-92-15-50
Fax: +33-1-64-46-10-65

● **Italy**

ANRITSU S.p.A.

Via Elio Vittorini, 129, 00144 Roma EUR, Italy
Phone: +39-06-509-9711
Fax: +39-06-502-24-25

● **Sweden**

ANRITSU AB

Botvid Center, Fittja Backe 1-3 145 84 Stockholm,
Sweden
Phone: +46-853470700
Fax: +46-853470730

● **Singapore**

ANRITSU PTE LTD.

6, New Industrial Rd., #06-01/02, Hoe Huat Industrial
Building, Singapore 536199
Phone: +65-282-2400
Fax: +65-282-2533

● **Hong Kong**

ANRITSU COMPANY LTD.

Suite 719, 7/F., Chinachem Golden Plaza, 77 Mody
Road, Tsimshatsui East, Kowloon, Hong Kong, China
Phone: +852-2301-4980
Fax: +852-2301-3545

● **Korea**

ANRITSU CORPORATION

14F Hyun Juk Bldg. 832-41, Yeoksam-dong,
Kangnam-ku, Seoul, Korea
Phone: +82-2-553-6603
Fax: +82-2-553-6604~5

● **Australia**

ANRITSU PTY LTD.

Unit 3/170 Forster Road Mt. Waverley, Victoria, 3149,
Australia
Phone: +61-3-9558-8177
Fax: +61-3-9558-8255

● **Taiwan**

ANRITSU COMPANY INC.

6F, 96, Sec. 3, Chien Kou North Rd. Taipei, Taiwan,
R.O.C.
Phone: +886-2-2515-6050
Fax: +886-2-2509-5519