

MD6430A

Network Data Analyzer

50 bit/s to 10 Mbit/s



One Instrument for Installation and Maintenance

For easy and fast Data Line Testing

- One unit supports installation and maintenance of leased lines, ISDN, and frame relay
- Single button quick test operation
- Lightweight, with a battery-operated function

The MD6430A Network Data Analyzer can measure errors on 13 different interfaces from leased lines (64 kbit/s to 6.3 Mbit/s), ISDN (BRI, PRI) and V/X series interfaces, making it suitable for installation and maintenance of a variety of networks.

Measurements include bit errors, alarms, delay time, frequency, digital level measurements, user pattern send/trace, etc., all of which can be displayed on the large color LCD.

Error performance (ITU-T G.821, G.826, M.2100) is available with various pseudorandom patterns, and user patterns up to 1024 characters. Frame Relay measurement function, ISDN signaling function (option) and a simultaneous two-channel monitoring function is also provided. Single button "quick" function and touch-screen ensure easy operation. This unit offers the user sophisticated functions required for installation and maintenance in a small compact unit.



● Many applications ranging from low-speed modems to high-speed digital lines

The MD6430A can evaluate the quality of lines ranging from low-speed modems to high-speed digital lines spanning 50 bit/s to 10 Mbit/s and also supports modern ISDN and frame relay protocols.

● Support for various interfaces

The MD6430A supports G.703 64k, I.430/I-430a 192k, G.703/G.704/I.431 1.5M, 2M, 2M CMI, 6.3M, V.24/V.28, V.35, V.36, RS-449, X.20, X.21, TTL/CMOS interfaces in a number of optional interface units designed to meet customer needs.

Units	Interfaces	Uses
MU643000A	G.703 64k, I.430/I430-a 192k, G.704/I.431 1.5M, G.704/I.431 2.0M, 2M CMI, G.704 6M	Europe and Japan
MU643000B	G.703 64k, I.430/I430-a 192k, G.704/I.431 1.5M, 2M CMI, G.704 6M	Japan
MU643000C	G.703 64k, I.430/I430-a 192k, G.703/G.704/I.431 2.0M	Europe

Note: All interface units support V.24/V.28, V.35, V.36, RS-449, X.20, X.21, and TTL/CMOS.

● Powerful measurement functions

Various measurements, such as error, alarm, clock slip, delay, frequency, and digital level can be performed as well as the ability to send user patterns with tracing functions.

● Simultaneous error measurement of various error parameters

The error count (bit error, parity error, and CRC error, etc.), error rate, block error count, block error rate, clock slip count, clock slip seconds, character error count, error performance (G.821, G.826, M.2100), synchronization loss, and alarm seconds can be measured simultaneously.

● Frame relay measurements

Frame relay network connections (conforming to PVC and ITU-T Q.933 Annex A) can be tested by the MD6430A. The user can also monitor the congestion status such as FECN, BECN, and CLLM.

● Optional ISDN signaling functions (BRI, PRI)

The unit can be connected to ISDN networks so that both voice communication and error measurement can be performed.

● Measurement between different interfaces

Measurements can be performed between different interfaces by setting the transmitting and receiving interfaces.

● Simultaneous two-line monitoring

Simultaneous monitoring of two lines permit error measurement to be performed on the T and R line (CRC error, code error, HDLC error, etc.) and alarm detection.

● Error data analysis and storage functions

Error data can be collected in log or histogram formats. This data can also be stored in internal memory or on a floppy disk for later analysis.

● Convenient quick functions

Once the measurement settings are stored in internal memory, they can be recalled and displayed just by pressing the Quick key. Up to 10 setting conditions can be stored in this way.

● Touch-screen

The touch-screen, large color LCD, and pop-up menus provide a much better GUI operating environment.

● Battery operation

When a commercial power supply is not available, the optional battery pack provides operation for up to 3 hours, and 5 hours in power save operation.

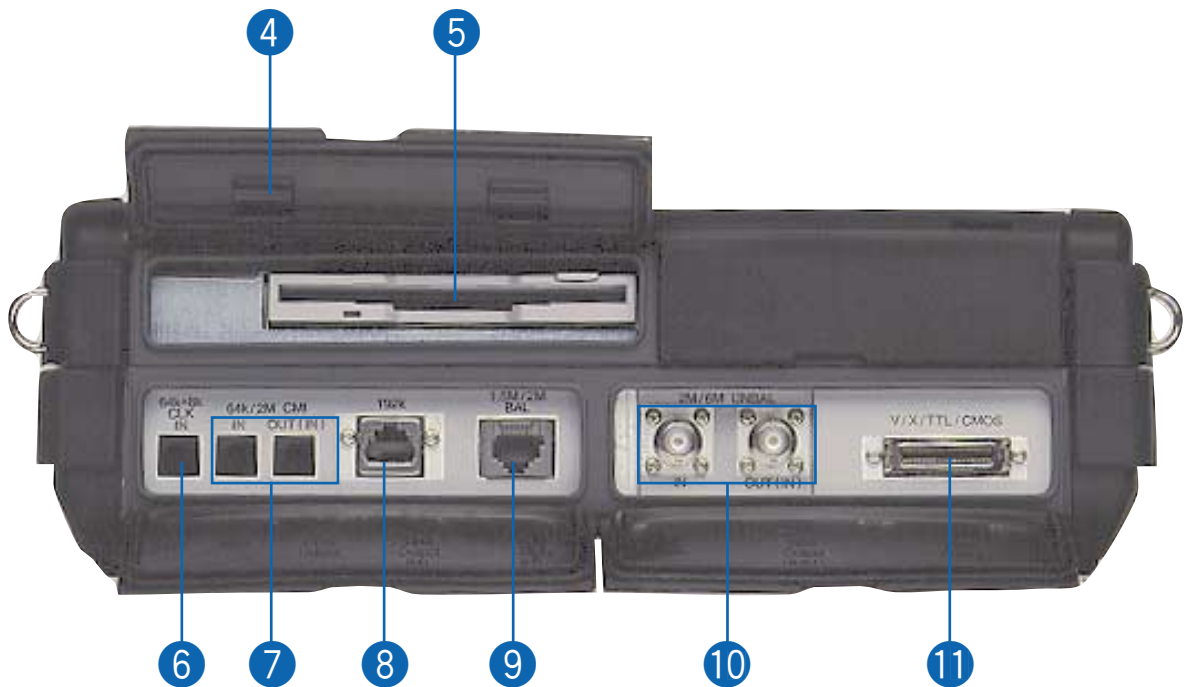

- ① Displays power and battery conditions
- ② For operations such as printing, access to quick operation screen (measurement condition recall screen), and scrolling display.
- ③ Most operations can be performed using this touch panel.
- ④ Touch pen holder
- ⑤ Floppy disk drive (for saving or reading data)
- ⑥ Input connector for 64k + 8k external clock
- ⑦ I/O Connector for 64k, 2M CMI interfaces
- ⑧ I/O Connector for 192k interface
- ⑨ I/O Connector for 2M BPL (BAL), 1.5M BPL (BAL) interfaces
- ⑩ I/O Connector for 2M BPL (UNBAL), 6M BPL (UNBAL) interfaces
- ⑪ I/O Connector for V, X, TTL/CMOS interfaces
- ⑫ For external printer
- ⑬ RS-232C Connector
- ⑭ Contrast adjuster
- ⑮ Voice head set connector
- ⑯ Loudspeaker



Applications

Several types of interfaces, including the ITU-T series, ensure connection with different measurement points. Measurement can also be performed between different interfaces.

● Testing high-speed digital lines

Back-to-back testing of high-speed digital lines can be performed using two MD6430A units via TDM-DSUs. This type of testing can also be performed by a single MD6430A using a loopback at the far end.

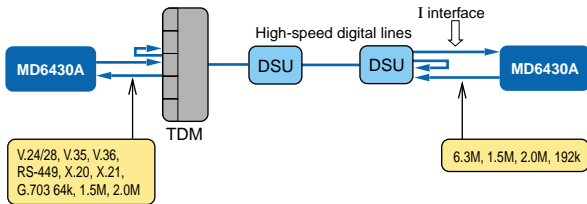

Unit testing from both ends can be performed by connecting the MD6430A to the line multiplexer high-speed interface at one end, and the MP1570A SONET/SDH/PDH/ATM Analyzer to the line multiplexer SDH interface at the other end. (MUX/DEMUX can be tested too.)

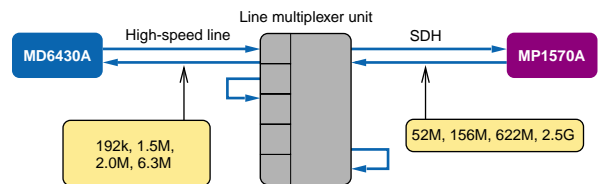

● Testing frame relay network lines

Back-to-back testing of frame relay network lines can be performed using two MD6430A units via DSUs. This testing is also possible using one unit and loopback inside the frame relay network.

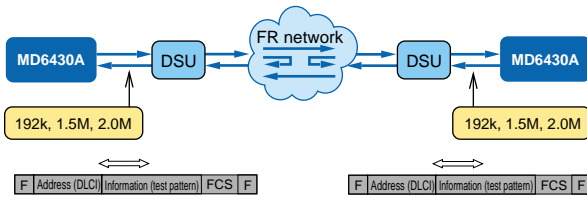

● Testing ISDN public lines

ISDN public telephone lines can be tested using two MD6430A units via DSUs. Individual BRI or PRI channels can be tested.

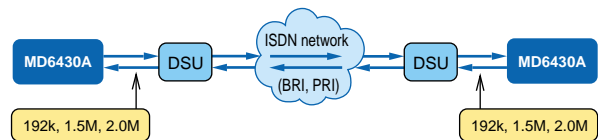

Testing of ISDN public lines is also possible using one MD6430A by transmitting signals to itself and looping back via the receiver side channel.

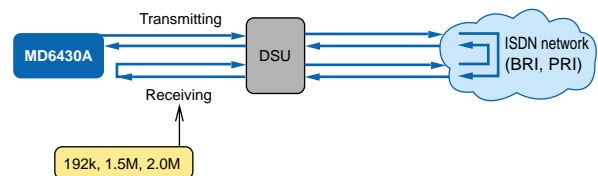

● Line multiplexer unit testing

Unit testing from both ends can be performed by connecting the MD6430A to the line multiplexer terminal interface at one end and to the high-speed interface at the other end. (MUX/DEMUX can be tested using one unit.)

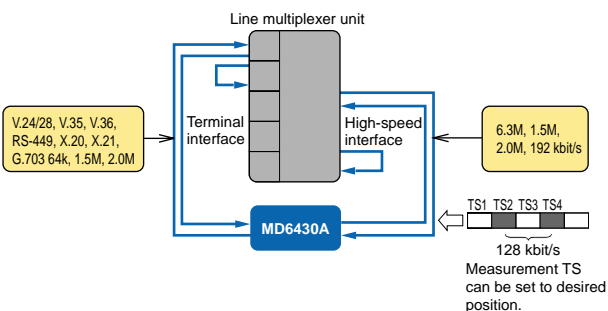

● Full range of error measurement screens

Various measurement items can be displayed simultaneously for error count, error rate, block error count, clock slip count, character error count, error performance (G.821, G.826, M.2100), HDLC error (bad frame, abort frame), and various types of alarm. The user can select the desired items and can display them using the zoom function.



● Substantial analysis functions

Error status and alarm condition can be logged and displayed as histograms. The received data can also be captured.

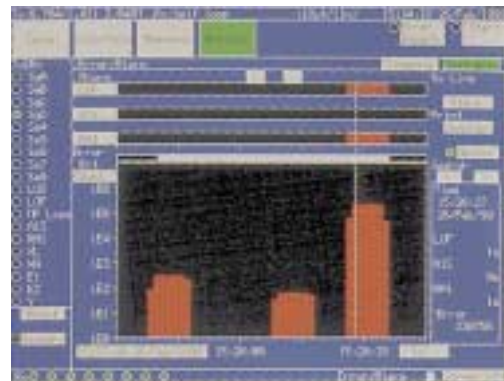
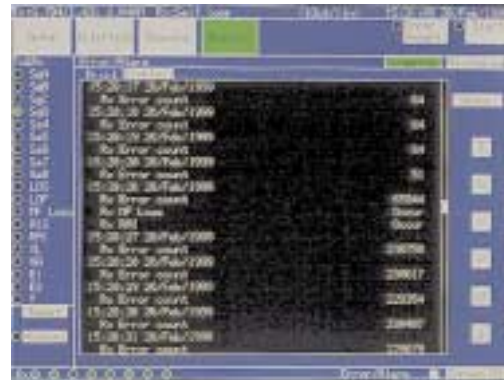

● Supports frame relay measurements

Specific DLCI connections can be checked. PVC status checking procedures are supported.

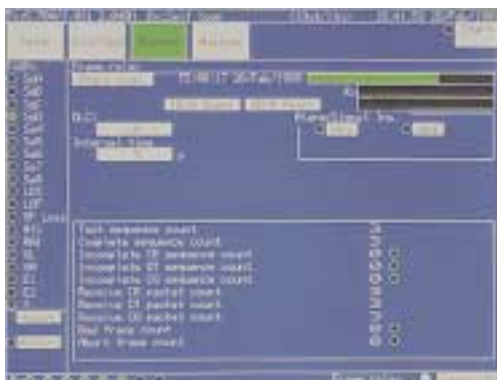
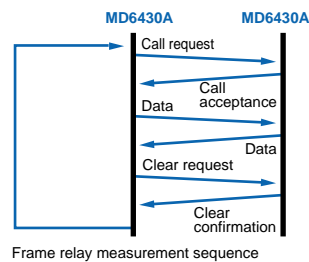

● Supports ISDN networks (BRI, PRI)

The unit can be connected to the ISDN public telephone network. Return testing using one unit can be done by using the call loop function as below.

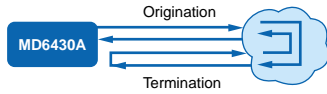

● Voice channel function

The CODEC function permits voice communications over a specified channel. Simultaneous voice communications and measurements are possible.

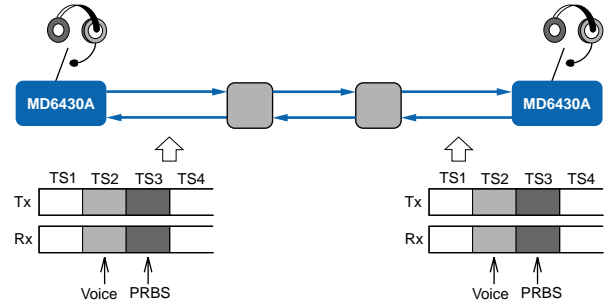

● Simultaneous monitoring of T and R lines

Error measurement of two lines (T and R lines) can be done simultaneously by using the MD6430A in the dual input mode.

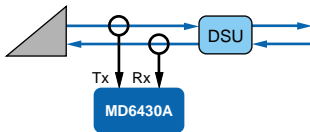

● Easy operation

The touch-screen and pop-up menus are quick and user-friendly, making operation easy for all levels of expertise.

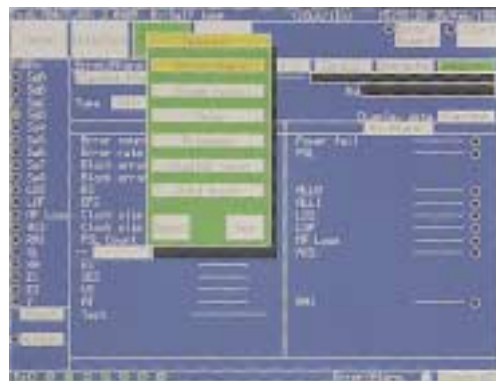

Specifications

Interface	High speed: G.703 64k, I.430/I430-a 192k, G.703/G.704/I.431 1.5M ^{*1, *2} , G.703/G.704/I.431 2.0M ^{*1, *3} , 2M CMI ^{*1, *2} , G.703/G.704 6M ^{*1, *2} (2-wire simultaneous monitoring) Low speed: V.24/V.28, V.35, V.36, RS-449, X.20, X.21, TTL/CMOS (Send/receive simultaneous monitoring)
Clock (high-speed interface)	Internal clock: 64 kbit/s, 1.544 Mbit/s ^{*1, *2} , 2.048 Mbit/s, 6.312 Mbit/s ^{*1, *2} (accuracy $\leq \pm 5$ ppm) External clock: 64k + 8k or slave sync to received data (slave oscillation range: $\leq \pm 100$ ppm)
G.703 64k clock mode	Centralized clock, codirectional clock
Code law (high-speed interface)	G.703 64k: AMI I.430/I430-a 192k: AMI G.703/G.704/I.431 1.5M: AMI/B8ZS ^{*1, *2} G.703/G.704/I.431 2.0M: AMI/HDB3 ^{*1, *3} 2M CMI: CMI G.703/G.704 6M: B8ZS ^{*1, *2}
Impedance	64k: 110 Ω /HIGH, 192k: 50/100 Ω /HIGH, 1.5M: 100 Ω /HIGH, 2 M: 75/120 Ω /HIGH, 2M CMI: 110 Ω /HIGH, 6M: 75 Ω /HIGH
Frames (high-speed interface)	G.704/I.431 1.5M ^{*1, *2} : 12MFP (G.704), 24MFP (G.704), 24MFP (NTT), unframe G.704/I.431 2.0M ^{*1, *3} : 16MFP (30B + D), 16MFP (31B), 2MFP (30B + D), 2MFP (31B), Unframe 2M CMI ^{*1, *2} : PBX (TTC), CRV, ST (send only), unframe G.704 6M ^{*1, *2} : 4MFP (G.704), unframe
Data bit rate (high-speed interface)	64k x n: 64 to 6272 kbit/s (n = 1 to 98 ^{*4} , sequential or mixed configuration may be selected.) 56k (1-7) x n: 56 to 5488 kbit/s (n = 1 to 98 ^{*4}) 56k (2-8) x n: 56 to 5488 kbit/s (n = 1 to 98 ^{*4}) 8k x n: 8, 16, 32 kbit/s 2.4k x n: 2.4 to 48 kbit/s (n = 1 to 20, sequential or mixed configuration may be selected for X.50 20 multiframe.) 0.6k x n: 0.6 to 48 kbit/s (n = 1 to 80, sequential or mixed configuration may be selected for X.50 80 multiframe.) Others: Signaling, 1.544 Mbit/s
Send clock (low-speed interface)	Internal clock Sync (ST1): 50 bit/s to 10 Mbit/s (5 bit/s steps. However, V.24/V.28 and X.20 up to 200 kbit/s) Async: 50, 75, 100, 110, 150, 200, 256, 300, 400, 500, 512, 600, 768, 800, 1k, 1.2k, 1.6k, 1.8k, 2k, 2.4k, 2.56k, 3k, 3.2k, 3.6k, 4.8k, 7.2k, 8k, 9.6k, 12k, 12.8k, 14.4k, 16k, 16.8k, 19.2k, 28.8k, 32k, 38.4k, 46k, 48k, 50k, 56k, 56.6k, 64k, 72k, 76.8k, 115.2k (bit/s) Self oscillation accuracy: $\leq \pm 5$ ppm External clock (ST2, RT): Frequency for each interface of 50 to 10 Mbit/s (ST2 may be inverted.)
Receive clock (low-speed interface)	External clock (RT): Frequency for each interface of 50 to 10 Mbit/s (May be inverted) Internal clock (Async): 50, 75, 100, 110, 150, 200, 256, 300, 400, 500, 512, 600, 768, 800, 1k, 1.2k, 1.6k, 1.8k, 2k, 2.4k, 2.56k, 3k, 3.2k, 3.6k, 4.8k, 7.2k, 8k, 9.6k, 12k, 12.8k, 14.4k, 16k, 16.8k, 19.2k, 28.8k, 32k, 38.4k, 46k, 48k, 50k, 56k, 56.6k, 64k, 72k, 76.8k, 115.2k (bit/s)
Error measurement pattern	Pseudorandom pattern: PRBS 6, 7, 9, 11, 15, 19, 20, 23, RPRBS 20 (reversed PRBS20), QRSS, positive/negative logic Programmable pattern: 8 bit repetitive (start-stop sync: 5 to 8 bits) Code pattern: 1:1, ALL 1, ALL 0 User pattern: 1 to 1024 characters (1 character steps), for character error measurement
Send pattern	User pattern: 1 to 128 kbyte
Error insertion	Error type: bit, bit + code, code Insertion types Single: 1 bit error inserted each time insert button pressed Repeat: 1 bit error inserted each second Cyclic: 2.5E-1 to 1.7E-7
Start-stop synchronization	Start bit length: 1 bit Stop bit length: 1, 1.5, 2 bits Data length: 5, 6, 7, 8 bits Parity: None, odd, even

Error/alarm measurement	<p>Detected errors: Bit, code, parity, CRC, frame, character</p> <p>Measurements: Error count, error rate, block error count, block error rate, ES, EFS, clock slip, clock slip seconds, pattern sync loss count/time, frame sync loss time, alarm time, signal loss time, AC power loss time</p> <p>Error performance: G.821, G.826, M.2100</p> <p>Measurement modes Single: 1 s to 99 d 23 h 59 min 59 s Repeat: 1 s to 99 d 23 h 59 min 59 s Manual: 1 y max.</p> <p>Measurement range Error rate: 1.00E-15 to 1.00E00, Error count: 0 to 9.99E15</p>
Pattern trace	<p>Trace byte count: 1 Mbit max.</p> <p>Trace start trigger: Manual, code detect</p> <p>Trace stop trigger: Manual, code detect, code mismatch detect, trace byte count</p> <p>Trigger detect delay: 0 to 8,000 bytes</p>
Frequency measurement	Measurement range: DC to 10 MHz, Accuracy: $\leq(\pm 5 \text{ ppm} \pm 1 \text{ digit})$
Delay time measurement (Sync. mode only)	Measurement range: 0 to 16 s (0.001 ms steps)
Frame relay measurement	<p>Measurement items: Correct test packet count, lost test packet count, HDLC bad frame count, HDLC abort frame count PVC connect confirmation test: To MD6430A or circuit loopback test (Conforms to ITU-T Q.933 Annex A)</p> <p>DLCI: 16 to 991 (1 steps)</p> <p>Test packet send interval time: 5 to 30 s (1 s steps)</p> <p>Traffic congestion status monitoring: BECN, FECN, CLLM message detection (Conforms to ITU-T Q.922 Annex A)</p>
Digital level measurement	<p>Code law: A-law, μ-law</p> <p>Measurement range: -60 to +3 dBm (0.1 dBm steps)</p> <p>Send pattern: 0 dBm, 1 kHz pattern (Conforms to ITU-T G.711)</p>
ISDN calling/called function	INS64, INS1500 (Option: MU643000A/B-01), Euro ISDN (Option: MU643000A/C-02)
MUX/DEMUX	Able to drop/insert specified channels in high-speed interface through X.21 interface at 64k x n (n = 1 to 98)
Voice communication	Voice communication possible in any TS in high-speed interfaces (except G.703 64 kbit/s)
Error analysis	Displays sequential error/alarm measurement data and graphs
Signal monitor lamp	Indicates status of each signal line
External printer Interface	Centronics, D-sub 25-pin connector
External printer output	<p>Enables printout of error measurement data</p> <p>Measurement start time: Prints time and measurement conditions</p> <p>During measurement: Prints specified error and alarm occurrence at each detected instance or at predefined time interval</p> <p>Measurement stop time: Prints measured total results</p> <p>Prints on screen contents</p>
Display	Color TFT-LCD (8.4 size)
Remote interface	RS-232C, D-sub 9-pin connector
Memory	3.5" FDD
Built-in timer	Year, month, day, hour, minute, second
Power supply	AC: 85 to 250 V, DC: Lithium ion battery (rechargeable, optional accessory), 50 VA
Battery operation time	3 h (max.) *5 h when using power save function
Operating temperature	0° to 50°C, (FDD and at battery usage: +5° to +40°C)
Dimensions and mass	290 (W) × 194 (H) × 94 (D) mm, ≤ 4.2 kg (excluding battery)
EMC	<p>EN61326 : 1997/A1 : 1998 (Class A),</p> <p>EN61000-3-2 : 1995/A2 : 1998 (Class D)</p> <p>EN61326 : 1997/A1 : 1998 (Annex A)</p>
LVD	EN61010-1 : 1993/A2 : 1995 (Installation Category II, Pollution degree2)

*1: Specification when using MU643000A Datacom Interface

*2: Specification when using MU643000B Datacom Interface

*3: Specification when using MU643000C Datacom Interface

*4: Max. n value depends on interfaces

Ordering Information

Please specify model/order number, name and quantity when ordering.

Model/Order No.	Name	Remarks
MD6430A	Main frame Network Data Analyzer	
	Standard accessories	
	Power cord: 1 pc	
G0104	ADP60WB-24.0 AC Adapter: 1 pc	100 to 240 Vac/24 Vdc converter
Z0406A	Touch pen: 1 pc	For touch panel
Z0402A	Protective cover: 1 pc	Protects display
W1542AE	MD6430A operation manual: 1 copy	Includes MU643000A/B/C
W1543AE	MD6430A remote control operation manual: 1 copy	Includes MU643000A/B/C
Z0417	MD6430A sample program: 1 pc	Remote sample program
Z0403A	Belt with hook: 1 pc	MD6430A carrying belt
	Units	
MU643000A	Datacom Interface Unit	For Europe and Japan
MU643000B	Datacom Interface Unit	For Japan
MU643000C	Datacom Interface Unit	For Europe
	Options	
MD6430A-01	GPIB	With GPIB cable 2 m
MU643000B-01	JT-Q921/Q931 ISDN signaling	
MU643000A-02	ETSI ISDN signaling	
MU643000B-01	JT-Q921/Q931 ISDN signaling	
MU643000C-02	ETSI ISDN signaling	
MU643000A-22	CAS/FAS option	For Europe and Japan
MU643000B-22	CAS/FAS option	For Japan
MU643000C-22	CAS/FAS option	For Europe
	Optional accessories	
J1026A	GPIB cable (for MD6430A-01's accessory), 2 m	
Z0404A	Lithium ion battery pack	Battery pack for main frame
B0441	Hard carrying case	
B0442	Soft carrying case	Attach case type (440W x 310H x 110D)
B0443	Rack mount kit	
A0006	Headset	
J0654A	Serial interface cross cable [D-Sub 9-pin (female)•D-Sub 9-pin (male)], 2 m	For remote control of main frame
J0661A	RS-232C straight cable [D-Sub 9-pin (female)•D-Sub 25-pin (male)], 2 m	For remote control of main frame
J0920B	Cross cable [D-Sub 9-pin (female)•D-Sub 25-pin (male)], 3 m	For remote control of main frame
J0913A	Measurement cable [D-Sub 25-pin (male)•half pitch 36-pin], 2 m	For V.24/V.28
J0914A	Measurement cable [V.35 connector (male)•half pitch 36-pin], 2 m	For V.35
J0915A	Measurement cable [D-Sub 37-pin (male)•half pitch 36-pin], 2 m	For V.36/RS-449
J0916A	Measurement cable [D-Sub 15-pin (male)•half pitch 36-pin], 2 m	For X.20/X.21 (Using B terminal as ST1 output type)
J0945	Measurement cable [D-Sub 15-pin (male)•half pitch 36-pin], 2 m	For X.20/X.21 (Using B terminal as ST2 input type)
J0929	Cross measurement cable [D-Sub 15-pin (male)•half pitch 36-pin], 2 m	For X.20/X.21 MUX/DEMUX
J0388B	DCE/DTE conversion adapter (D-Sub 25-pin)	For V.24/V.28
J0390	DCE/DTE conversion adapter (D-Sub 34-pin)	For V.35
J0392B	DCE/DTE conversion adapter (D-Sub 37-pin)	For V.36/RS-449
J0917A	TTL/CMOS connection box*1	I/O connector: BNC type
J0923	Measurement cable (both-end Amphenol, half pitch 36-pin), 1 m	For connection between MD6430A to TTL/CMOS
J0463C	Measurement cable [both-end 8-pin modular (RJ45) with shield], 2 m	For 192k
J0959B	Measurement cable (RJ45 8-pin modular•clip), 2 m	For 192k
J0844A	ISO10173 cable [both-end 8-pin modular (ISO10173)], 2 m	For 1.5M, 2M
J0127B	Coaxial cord (BNC-P•RG58A/U•BNC-P), 2 m	For 2M, 6M
J0538	Coaxial cord (3CV•CPP•3CV)	For 6M
J0960B	Measurement cable (Mini-BANTAM•clip), 2 m	For 64k, 2M CMI
J0921B	Measurement cable [8-pin modular (ISO10173)•M-1PS], 2 m	For 1.5M, 2M
J0922B	Measurement cable (Mini-BANTAM•M-1PS), 2 m	For 64k, 2M CMI
J0924B	Measurement cable (Mini-BANTAM•I-214APS), 2 m	For external input clock (64k + 8k)
J0930	Measurement cable (Mini-BANTAM•M-3912), 2 m	For 64k (Siemens type)
J0538	Coaxial cord (C-H3T type A plug•BNC), 2 m	For 6M
J0946A	Measurement cable [8-pin modular (ISO10173)•M-3912], 1 m	For 1.5M/2M
J0946B	Measurement cable [8-pin modular (ISO10173)•M-3912], 2 m	For 1.5M/2M
J0950	Measurement cable [8-pin modular (ISO10173)•clip], 2 m	For 1.5M/2M

Model/Order No.	Name	Remarks
J0963	Balance cable (RJ-ISO10173), 2 m	For 192k
J0969C	Unbalance cable [SP3CP/3CV-P (BNC)], 2 m	For 6M
J0925B	Y cable (D-sub 25-pin•half pitch 36-pin/D-sub 25-pin), 2 m	For V.24/V.28 monitor
J0926B	Y cable (D-sub 25-pin•half pitch 36-pin/D-sub 25-pin), 2 m	For V.35 monitor
J0927B	Y cable (V.37•half pitch 36-pin/D-sub 37), 2 m	For V.36/RS-449 monitor
J0928B	Y cable (D-sub 15-pin•half pitch 36-pin/D-sub 15-pin), 2 m	For X.20/X.21 monitor

*1: Cable (J0923B) required when using with TTL/CMOS interface

Note: For details of the measurement cable, refer to the Measurement Cable Selection Guide in the MD6430A Application Note.

● Lithium ion battery pack (Z0404A)



● Hard carrying case (B0441)



● Head set (A0006)



Anritsu

Specifications are subject to change without notice.

**ANRITSU CORPORATION
MEASUREMENT SOLUTIONS**

5-10-27, Minamiazabu, Minato-ku, Tokyo 106-8570, Japan
Phone: +81-3-3446-1111
Telex: J34372
Fax: +81-3-3442-0235

● **U.S.A.**
ANRITSU COMPANY

North American Region Headquarters
1155 East Collins Blvd., Richardson, Tx 75081, U.S.A.
Toll Free: 1-800-ANRITSU (267-4878)
Phone: +1-972-644-1777
Fax: +1-972-671-1877

● **Canada**
ANRITSU ELECTRONICS LTD.

700 Silver Seven Road, Suite 120, Kanata,
ON K2V 1C3, Canada
Phone: +1-613-591-2003
Fax: +1-613-591-1006

● **Brasil**
ANRITSU ELETRÔNICA LTDA.

Praia de Botafogo 440, Sala 2401 CEP 22250-040,
Rio de Janeiro, RJ, Brasil
Phone: +55-21-5276922
Fax: +55-21-537-1456

● **U.K.**
ANRITSU LTD.

200 Capability Green, Luton, Bedfordshire LU1 3LU, U.K.
Phone: +44-1582-433200
Fax: +44-1582-731303

● **Germany**

ANRITSU GmbH
Grafenberger Allee 54-56, 40237 Düsseldorf, Germany
Phone: +49-211-96855-0
Fax: +49-211-96855-55

● **France**

ANRITSU S.A.
9, Avenue du Québec Z.A. de Courtabœuf 91951 Les
Ulis Cedex, France
Phone: +33-1-60-92-15-50
Fax: +33-1-64-46-10-65

● **Italy**

ANRITSU S.p.a.
Via Elio Vittorini, 129, 00144 Roma EUR, Italy
Phone: +39-06-509-9711
Fax: +39-06-502-24-25

● **Sweden**

ANRITSU AB
Botvid Center, Fittja Backe 1-3 145 84 Stockholm,
Sweden
Phone: +46-853470700
Fax: +46-853470730

● **Spain**

ANRITSU ELECTRÓNICA, S.A.
Europa Empresarial Edificio Londres, Planta 1, Oficina
6 C/ Playa de Liencres, 2 28230 Las Rozas. Madrid,
Spain
Phone: +34-91-6404460
Fax: +34-91-6404461

● **Singapore**

ANRITSU PTE LTD.
10, Hoe Chiang Road #07-01/02, Keppel Towers,
Singapore 089315
Phone: +65-6282-2400
Fax: +65-6282-2533

● **Hong Kong**

ANRITSU COMPANY LTD.
Suite 719, 7/F., Chinachem Golden Plaza, 77 Mody
Road, Tsimshatsui East, Kowloon, Hong Kong, China
Phone: +852-2301-4980
Fax: +852-2301-3545

● **Korea**

ANRITSU CORPORATION
14F Hyun Juk Bldg. 832-41, Yeoksam-dong,
Kangnam-ku, Seoul, Korea
Phone: +82-2-553-6603
Fax: +82-2-553-6604-5

● **Australia**

ANRITSU PTY LTD.
Unit 3/170 Forster Road Mt. Waverley, Victoria, 3149,
Australia
Phone: +61-3-9558-8177
Fax: +61-3-9558-8255

● **Taiwan**

ANRITSU COMPANY INC.
6F, 96, Sec. 3, Chien Kou North Rd. Taipei, Taiwan
Phone: +886-2-2515-6050
Fax: +886-2-2509-5519